

PRODUCTION INTEGRATION OF FIBER OPTICAL SENSORS
EMBEDDED IN NEW ROTOR BLADES FOR REAL TIME LOADS FEEDBACK

Jens-Thomas Wernicke, Rain Byars, Jody Shadden, Christiane Schmoeller
WindForce GmbH
Am Lunedeich 158, Bremerhaven, Germany
Ph. +49 471 90 26 28 60
Fax +49 471 90 26 28 69
info@wind-force.com

Abstract

Individual blade pitch control utilizing rotor load feedback presents the potential for significant improvements in cost, performance and reliability for future WTGs benefiting both the onshore and offshore markets. This type of control requires a stable and cost effective measurement input from load sensors during operation of WTG. In addition to the performance requirements, the system must be reliable for the lifetime of the turbine, cost effective for volume deployment, and the system must not interfere or degrade the turbines' components or operation in any way. Individual blade pitch control also requires a pitch system capable of pitching each blade independently. Most new current wind turbine designs already incorporate such a system.

In this paper we present an FOS load measurement system that meets these requirements and has been successfully demonstrated to fulfill the acceptance criteria for advanced control inputs. Fiber Optical Sensors (FOS) have been tested successfully in composite blades on wind turbine generators (WTG), showing their capability to perform under both laboratory and field conditions.

In this paper we present an FOS load measurement system that has been successfully integrated into a large volume production run of new wind turbine rotor blades. We discuss production techniques used for maximizing efficiency and quality of installation.

Further, we present strategies for processing and using the data in controls algorithms as well as system architecture with the loads measurement system integrated into a standard electromechanical wind turbine pitch system, with effects including lower system cost, simplified installation, and streamlined communication and data processing.

Paper presented at the European Wind Energy Conference 2007
May 9, 2007, Milan, Italy

1. Introduction

Every day wind energy is being pushed to new limits; both in terms of operating conditions and in terms of size. To meet these challenges turbine designers and wind park developers need new tools to ensure their products will meet goals of operating cost and availability. Recent innovations in fiber optic load sensing have created such a tool, which will expand the options for advanced monitoring and control of turbines which are pushing the envelope, and open up possibilities for huge gains in availability and operating cost.

Today's turbines are being installed in more places, under more diverse conditions, than ever before. Most wind turbines are designed for a twenty year life. This life span is dependent on the cyclic load seen by the turbine's rotor, and as such, accurate assumptions and about the characteristics which influence this loading are critical to the design. However as the wind energy market expands and changes, many sites being used or considered for wind energy production present wind conditions which are further and further outside of well understood and defined wind regimes. There is a huge technical risk associated with putting even proven technology into poorly understood conditions.

FIBRADAPT™ uses new criteria and input from online load measurements during the turbine life time as innovative input into turbine controls to significantly decrease operational cost as the main driver for profit across the investment time.

2. Technology of FIBRADAPT™

FIBRADAPT™ provides data from optical fiber sensors based on Fiber Bragg Gratings (FBG) which are commonly used in fiber optic communication systems. Unlike most fiber optical sensors, this system employs a "cold written" FBG, which allows the fiber to retain its structural integrity thus remaining robust for handling and installation.

Fiber optical sensors have wide a range of advantages in comparison to strain gauges, especially under severe environmental conditions such as those found during wind turbine operations. The benefits and main features of fiber optical sensors as they apply to wind turbines are as follows.

- Small cross section, low weight, very low heat conduction
- Long signal transmission lines, with very low or negligible losses
- Long term stability under operation in hostile environments (EMI, weather, chemicals, high/low temperatures)
- Remote, electrically passive sensors, ideal galvanic separation
- Ideal to embed in GRP structures
- Multiple sensors (up to 100) linked on a single conductor with only one mechanical connection point.

2.1. Structure of the Fiber Optical Sensor

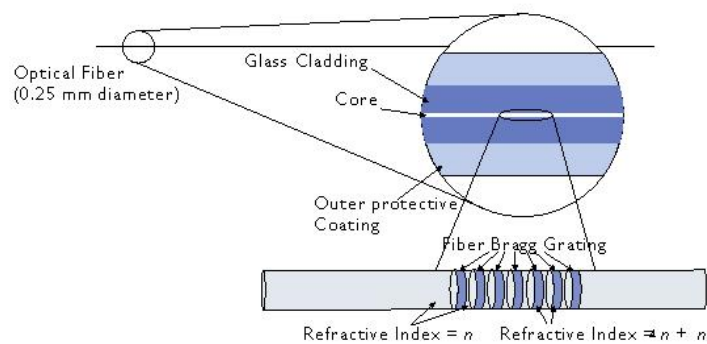

Figure 1: Structure of the fiber optical sensor

The optical fiber has a diameter of 0.25 mm which includes the core, the glass cladding and the coating. The FBG sensor consists of a small periodic variation in the refractive index of the optical fiber core. The periodic variation is made by a high powered ultraviolet laser. By irradiating the core material of photo sensitive quartz glass locally with UV-light, the refractive index is increased at certain locations along the fiber. These locations are spaced in equal distances, the entire sensor having a length of about 3 – 14 mm. [1]

2.2. Structure of the Measurement System

The main components are:

1. Fiber Sensor Interrogator (FSI) as source and receiver of light, data processor, communication interface, transformer, software
2. Interconnecting Fiber (IF) for data transfer between FSI and sensor arrays
3. Sensor Arrays embedded in the blade structure
4. Temperature compensation sensor
5. Support brackets (customized according to design requirements)

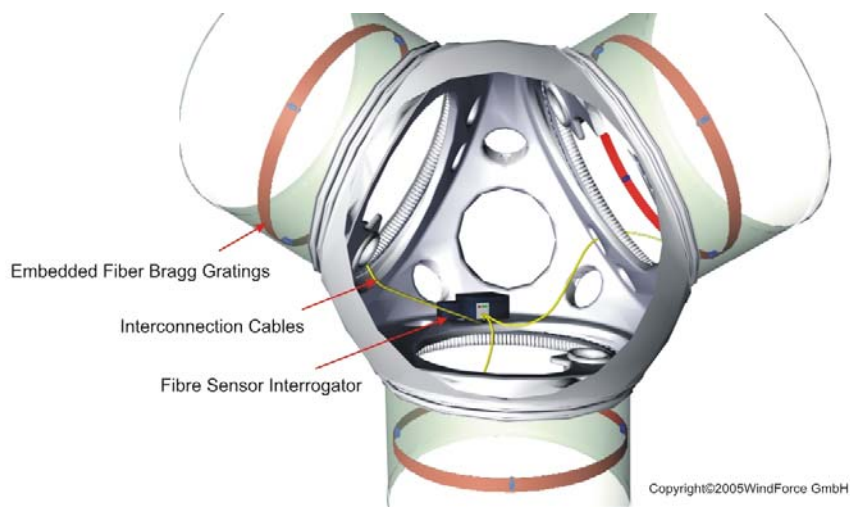

Figure 2: Structure of the Measurement System in a wind turbine

2.3. Function of the Fiber Optical Sensor

A light source provides a broadband input signal into the fiber. When passing an FBG, the light is reflected within the pre-selected narrow wavelength band around λ_B . When the sensor is exposed to a strain, the distances of the grating change, which also changes the wavelength of the reflected light. The analysis of the characteristic of the reflected light is used to measure the strain at the sensor location. Shifts in the reflected wavelength are proportional to change in elongation caused by temperature, or load induced strain which can be computed to stress based on the component geometry. [2]

Because the optical strain sensor is sensitive to temperature changes, the strain measurements must be temperature compensated.

One of the main advantages of the fiber optic sensor is the multiplexing feature using one single fiber with multiple FBGs without interference between the single measurement points. This system is based on time division multiplexing, which allows the interrogation unit to distinguish between individual strain sensors by using their physical position in the array as a reference. By measuring the time taken for the light to travel from the interrogation unit to the sensor and back, it is possible to calculate its physical distance from the interrogation unit, and therefore which sensor the signal originated at. [3]

3. Integration into the Pitch System

The optical fiber sensors are embedded into the blade root as shown in Figure 2. The measurement system can be integrated into the wind turbine pitch system for production systems, as shown in figure 3. The FSI acquires the sensor signals and processes these values. The bending moment M_b in flapwise and edgewise direction will be transferred with a frequency of 25 Hz to the Pitch System Control Unit or to the Turbine Controller.

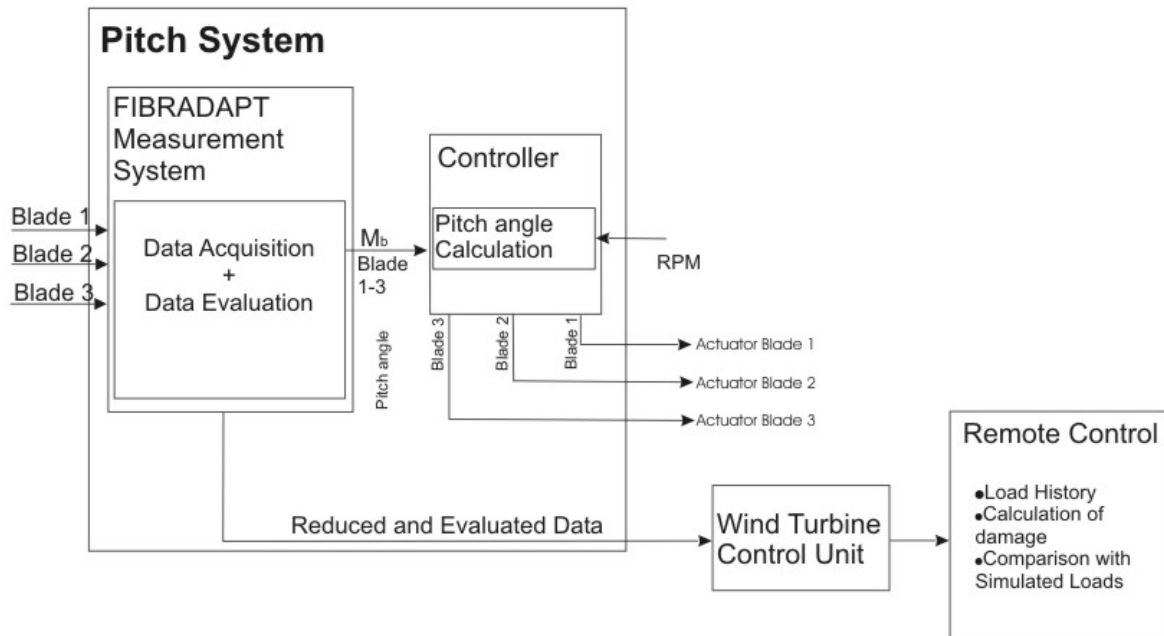

Figure 3: Integration into the Pitch System

4. Individual Blade Pitch Control

With large wind turbines there is significant variation in load across the face of the rotor. This can be the result of wind variation including shear and upflow, or turbine design and control, including yaw misalignment or rotor imbalance. Active individual blade pitch control based on load feedback from the blades can result in drastic decreases in fatigue loads in the rotor, and in the entire wind turbine structure.

The wind speed variations across the rotor disc result in a large once-per-revolution, or $1P$, component in the blade loads, together with harmonics of this frequency, i.e. $2P$, $3P$, $4P$. [4] As shown in figure 4 the $1P$ frequencies are particularly significant and these can be reduced by individual blade pitch control at the $1P$ frequency, 120° out of phase at the three blades. [4]

To achieve active control, bending moment in the flapwise and edgewise directions from each blade are required at a scan frequency of 10 to 20 Hz. [4] FIBRADAPT™ provides this input by means of four blade root sensors in each blade (a pair of flapwise sensors and a pair of edgewise sensors), with a scan frequency of 25 Hz, which is more than adequate to perform the active control algorithms.

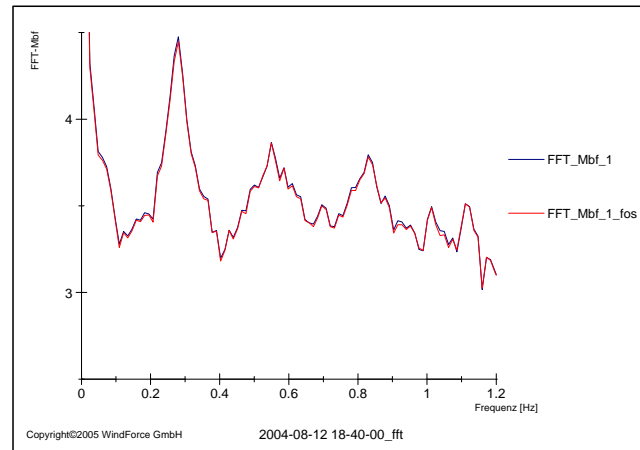

Figure 4: Frequency analysis from a 10 minute flapwise sensor signal

4.1. Control Strategies

The control scheme, described in more detail in [4], transforms the three blade root out of plane bending moment signals (derived from the flapwise and edgewise signals resolved through the pitch angle) into two orthogonal d- and q- axes (which can be thought of as the horizontal and vertical axes) [5]. A controller for each axis generates a pitch demand for that axis, and the two d- and q- axis pitch demands are converted by the reverse transformation to give pitch demand increments for each blade. These are each summed with the collective pitch demand (which controls torque and thrust, and hence rotational speed, tower vibration etc.) to give a total pitch demand for each blade. With this scheme fatigue loads on rotating components are reduced by typically 20 - 40% [6].

5. Production in Series

The Fibradapt™ system has been implemented into a production series of wind turbine blades of rotor diameter greater than 90 meters. The sensor assemblies, interconnecting cables, and central Fiber Sensor Interrogator unit have been optimized with respect to cost, ease of installation, and rugged construction for long life.

5.1. Fiber Sensor Interrogator (FSI)

As shown in figure 5, the FSI has been packaged for simple installation into the electrical cabinet of an electromechanical pitch system in the hub of a wind turbine. The compact box is equipped with plug-in connections for fiber optic sensors, power, and communications.

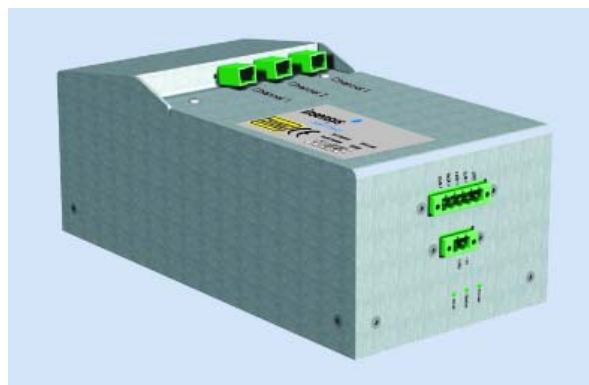

Figure 5: The Fiber Sensor Interrogator

5.2. Fiber Optic Sensors

As shown in figure 6, the fiber optic sensors have been packaged into low profile and rugged patches for simple and quick attachment to the rotor blade surface. The connection box for the fiber optic connection point is also optimized for blade surface lamination.



Figure 6: The Fiber Optic Sensor and Connection Box

6. Further Developments

Active control field testing

A prototype turbine will be commissioned in July 2007 which will be used as a test platform for individual blade pitch control using FIBRADAPT™ blade load input.

7. References

- [1] *Fiber Bragg Gratings*, R. Kashyap, March 1999
- [2] *Fiber Bragg Gratings Fundamentals and Applications in telecommunications and sensing*, A. Othonos, K. Kalli, June 1999
- [3] *Novel resonant cavity TDM demodulation scheme for FBG sensing*, G.D. Lloyd and I. Bennion, L.A. Everall, K. Sugden
- [4] *Developments in Individual Blade Pitch Control*, E.A. Bossanyi, Paper presented at the EWEA special topic conference "The Science of making Torque from Wind" DUWIND, Delft University of Technology, The Netherlands, April 19-21 2004
- [5] *Two-reaction theory of synchronous machines*, R.H. Park, *Trans. AIEE*, 1929, **48**.
- [6] *Active Wind Turbine Control Utilizing Measurements from Fiber Optical Load Sensors to Adjust Individual Blade Angle Integrated in to an Electromechanical Pitch System*, J.T. Wernicke et al, Paper presented at the DEWEK 2006 8th German Wind Energy Conference November 22 and 23, 2006 - Bremen, Germany