



720 Series Claw Bucket

Table of Contents

USER AND VEHICLE IDENTIFICATION	3
INTENDED USE	3
SAFETY NOTICE	3
SAFETY	4
INDUSTRIAL TRUCK.....	4
GROUND WORKERS	4
CLAW-LOADER OPERATORS.....	5
INSTALLATION	6
GENERAL MOUNTING INSTRUCTIONS	6
DETAILED MOUNTING INSTRUCTIONS	6
QUICK-ATTACHMENT BRACKET MOUNTING.....	6
STANDARD BRACKET MOUNTING	7
MODIFICATION TO HAUL TRUCK.....	7
HYDRAULICS	8
OPERATION.....	9
MAINTENANCE DETERRENTS.....	10
MOUNT CLAW PROPERLY	10
ADJUST CLAW PROPERLY	10
OPERATE CLAW PROPERLY	10
INSPECT CLAW DAILY FOR ABRASIVE WEAR.....	11
Wear Surfaces.....	11
Bearings.....	11
Hydraulics	11
Safety Labels	11
Parts Damage.....	11
REPLACEMENT PARTS	12
720 CLAW PARTS LIST.....	12
ILLUSTRATION 720 CLAW PARTS LIST	13
720 CLAW HYDRAULIC PARTS LIST	14
720 CLAW CYLINDER PARTS LIST	15
WARRANTY	16

USER AND VEHICLE IDENTIFICATION

User _____

City _____

Model _____

Serial Number _____

Rated Capacity of Bucket (lbs.) _____

Built to attach to _____

Loader Model _____

Date of Manufacture _____

INTENDED USE

The Claw is designed to harvest loose, lightweight materials from hard, flat surfaces. The most typical use is to pick up the yard and garden debris from the city streets. Do not exceed the load carrying capacity stated on the front page of this manual. Overloading the Claw can cause the bottom blades to bend down. Increasing the hydraulic pressure to the Claw or the size of the hydraulic cylinder will put too much force into the mechanism when both opening and closing and can cause failure of the sidewalls and hinges. Do not use the Claw for digging, pulling fence posts, battering, lifting slabs of concrete or as a work platform.

SAFETY NOTICE

Read the safety section before doing anything else, and read the whole booklet before attempting to use or operate the Claw. This booklet should be read by everyone who works with or around the Claw.

SAFETY

The Claw fits on a wheel loader, industrial tractor, backhoe, or similar vehicle. When so installed, Federal and State OSHA's call the Claw-loader (the Claw and vehicle to which it is attached) a "power industrial truck." As such, it is subject to certain several and specific safety regulations relating to the components and to operation. (The Federal OSHA requirements are spelled out in Federal Regulations, Title 29 Section 191.178.) Many State OSHA regulations call for the posting of several Safety Instructions to Employees. A typical set is as follows:

INDUSTRIAL TRUCK

1. Securely fasten your seatbelt if the vehicle has a ROPS.
2. Where possible, avoid operating the vehicle near ditches, embankments, and holes.
3. Reduce speed when turning, crossing slopes and on rough, slick, or muddy surfaces.
4. Stay off slopes too steep for safe operation.
5. Watch where you are going, especially at row ends, on roads and around trees.
6. Do not permit others to ride.
7. Operate the vehicle smoothly: no jerky turns, starts, or stops.
8. Hitch only to the drawbar and hitch points recommended by the vehicle manufacturer.
9. When vehicle is stopped, set brakes securely and use park lock if available.

In addition to the above, there are specific safety points related to the Claw. The Claw-loader seldom works alone. Most often the Claw-loader is part of a pickup-and-haul system; there is usually a truck (the haul truck) into which the picked-up materials are deposited. Safety and the safe operation considers:

- The Claw loader operator
- The haul truck operator
- All other people who may be in the vicinity
- All the equipment

GROUND WORKERS

1. The closing sidewalls of the Claw pinch hard; stay clear of them at all times and keep your tools clear.
2. When the Claw squeezes on some materials something could squirt out or whip around and hurt you. Stay clear of the opening and closing Claw.
3. The opening sidewalls can easily knock a person over; stay clear of the Claw.
4. The Claw-loader moves forward and backward; stay out of the forward and backward paths of the vehicle.
5. Do not ride in or on the Claw, or in the loader to which the Claw is attached.
6. Do not use the Claw as an elevated work platform.
7. Do not work on or adjust the Claw unless it is on the ground, the vehicle is shut off, and no one can touch any controls.

CLAW-LOADER OPERATORS

1. The closing sidewalls pinch hard. Be sure no one and no tool will be caught when you close the Claw. Also, be careful what you close the Claw on; the closing pressure can cause materials to squirt out or to whip around and cause injury or damage.
2. A person can be hit and knocked over by the sidewalls opening up. Be sure no one is in the way when you open the Claw.
3. Be sure no one is in front of you or behind you when you drive the Claw-loader either forward or backward.
4. To prevent overturning when moving keep the Claw low, 20 to 30 cm above the ground is a good position. Lift the Claw high only when unloading or with the loader not moving or moving only short distances at very slow speeds.
5. Do not let the Claw or the contents within the Claw impair your traveling vision.
6. Do not use the Claw for battering or ramming. The Claw is used primarily for picking up loose, free-standing material (leaves, brush, snow, etc.)
7. Do not let anyone ride in or on the Claw or in or on the loader.
8. Do not let anyone use the Claw as an elevated work platform.
9. Do not work on or adjust the Claw unless you have put the Claw safely on the ground with no vehicle weight supported by the Claw and have shut the engine off. If the bottom surfaces of the Claw are to be worked on, raise the Claw, tilt it 90 degrees forward so that the toe part is down and lower it so that the toes rest on the ground without supporting any vehicle weight, shut the engine off, and set the vehicle brakes.
10. When leaving the Claw unattended, be sure it is resting on the ground, engine is turned off, the brakes are on, and the ignition key is removed. Be sure that none of the vehicle weight is supported by the Claw.
11. The Claw may occasionally get a branch or other material jammed in the mechanism. Shut the loader off while removing the jam. If the first attempt is not successful, work the mechanism a few times and shut everything off again before pulling out the jammed material.

INSTALLATION

GENERAL MOUNTING INSTRUCTIONS

Read the safety instructions of this manual before proceeding further. Always be sure the vehicle engine is off and the Claw is on a firm, stable surface when working on the Claw or the vehicle.

Installation of the Claw on the loader is usually a part of the purchase arrangement and is taken care of by the dealer. If this is not the case see 'Detailed Mounting Instructions' of this section. The standard cylinders for the 720 Claw are four inches in diameter and the Claw will operate satisfactorily for most applications with supply pressures of 1000 to 2500 psi. High pressures will provide high pinch forces and provide best pickup of compacted materials. However, the pressure should not exceed 2500 psi. This could cause overstressing of structural members and bearing surfaces, and premature failure of hydraulic components. Pressures are limited through the installation of pressure control valves.

It is important to control the hydraulic oil flow rate to each end of the Claw cylinders. The Claw should open or close in two to three seconds. A faster action develops too much inertia which, again, will overstress the mechanism and cause premature failure of structural members and bearing surfaces. Should the Claw exceed the recommended opening or closing time call Tink, Inc. for assistance.

DETAILED MOUNTING INSTRUCTIONS

The mechanical attachment of the Claw to a vehicle such as a wheel loader, an industrial tractor, or a backhoe-loader is simple. Most Claws are ordered with brackets attached. In this case it is necessary only to remove the pins of the existing bucket, back off the vehicle and drive it to the Claw. The pins which were removed from the standard bucket are then used to attach the Claw to the vehicle. The final step is to connect the Claw's cushion valve to the vehicle's directional control valve using two hoses and flow control valves, installed if needed at convenient points in these two lines. (Be sure to monitor hydraulic oil temperature when flow control valves are used.) Some Claws are ordered for use with quick-attach devices. Consult your dealer for installation of this equipment. The Claw can also be mounted on a front loading garbage truck, a dump truck, or on similar vehicles. Consult your dealer regarding such special applications.

QUICK-ATTACHMENT BRACKET MOUNTING

A normal materials bucket is usually mounted by the manufacturer so that it will tilt back about 35 to 45 degrees when in the down position, tilt forward about 65 degrees when at an intermediate height and tilt forward about 45 degrees when in the up position. With the Claw, it is preferable to have the tilt in the up position about 65 to 75 degrees. This will allow material such as wet leaves to discharge more easily into open-top trucks. (If discharge is only to be into packer trucks the normal setting is usually satisfactory as discharge is at intermediate height). To obtain a greater dump angle in the raised position it is necessary to mount the quick-attach female to the Claw with the upper end of the female tilted back from the Claw approximately 15 to 20 degrees. The proper setting can be determined by observing a vehicle with a normal bucket in place.

In some brands of quick-attachment brackets, the webs connecting the female to the bucket or other device provide the rigidity and strength necessary to adequately support the female component. If this is not the case with your device, be sure to provide strengtheners otherwise, the female will deform and the Claw will not attach and detach as easily as it should.

STANDARD BRACKET MOUNTING

The Claw usually replaces a standard materials bucket. If the Claw has been provided with a quick attachment device (American Coupler Systems, Balderson, etc....) refer to that manufacturer's instructions for proper mechanical hookup. See, also, the section of these installation instructions entitled "Quick Attachment Bracket Mounting." If Tink, Inc. has provided its standard brackets, proceed as follows:

Place the Claw on a firm, horizontal surface at ground level. If necessary insert thin spacers under the bottom of each sidewall to prevent rocking of the Claw. Be sure holes for mounting pins are free of any obstructions and coat lightly with grease.

If standard bucket is still attached to the vehicle, which will be used for the Claw, drive the vehicle to a firm, horizontal surface. Lower the bucket to the ground. Be sure the bucket is stable and none of its weight is carried by the vehicle. Turn off the engine and work the hydraulic control levers back and forth to relieve any pressure, which may be in the lines.

Disconnect the existing materials bucket by removing the two large pins, which attach the lift arms to the bucket, and one or two large pins which attach the tilt arms to the bucket. Save all washers, spacers, retainers, pins, etc. as they will be used to attach the Claw to the vehicle. If the existing materials bucket is connected hydraulically to the vehicle's (four-in-one bucket, side-dump bucket, etc.), disconnect the hydraulic lines from the bucket. Be sure no one is near or on the buckets or vehicle and back the vehicle away from its bucket.

Be sure no one is on or near the Claw or vehicle. Drive the vehicle to the Claw, raise or lower the vehicle lift arms to align their holes with the corresponding holes in the Claw mounting brackets. Turn off the vehicle's engine and insert the pins, washers, spacers, retainers, etc. from the vehicle bucket disassembly. (If there was no bucket attached to the vehicle, it may be necessary to purchase standard pins, washers, spacers, retainers, etc. as supplied by the vehicle manufacturer). Be sure no one is on or near the Claw or vehicle and start the vehicle's engine. Adjust its tilt arms to align their holes with the corresponding holes on the Claw mounting brackets. Turn off the vehicle's engine and insert the pins, washers, spacers, retainers, etc. Check to be sure all retainers are properly locked. Be sure no one is on or near the Claw or vehicle and start the vehicle's engine. Raise and lower the Claw and tilt it forward and back to be sure that there is no mechanical interference with the Claw in any position. If there is, correct this interference before proceeding. This completes the mechanical attachment procedure.

MODIFICATION TO HAUL TRUCK

The claw and loader will work with maximum efficiency only if the haul vehicle into which the material is deposited is adapted to the Claw. If you will use an open-top dump truck make sure the loader can reach over the sideboards, tilt the Claw, and discharge its load. Some dump truck can also be loaded from the rear with the Claw pushing loose material forward from the back when the truck is partially full.

If the Claw is to dump into the hopper of a rear loading packer truck two things need to be considered:

1. The Claw will not get hung up on the rams, levers and mechanism within the hopper. Most rear loading hoppers are reasonably "clean" inside so this may not be too much of a problem. However, protection of the hopper is usually necessary; a 6" x 5' timber (or even a railroad tie) set into cradles has been very successful on most packer trucks.
2. The hopper of the usual packer truck does not extend out and up far enough to catch all debris when the Claw is opened. An extension to the hopper is needed. If this is made triangular (peaked at the center, low on two outside edges) it will match the triangular opening of the open Claw and it will still be easy to put waste material into the hopper by hand.

HYDRAULICS

Claw use flow dividers which require 10-micron filtration. 10-micron filtration is standard on most vehicles with which the Claw will be used. Be sure the hydraulic system is clean and install a new 10-micron filter. Flow dividers do NOT normally function fewer than 8 GPM. If the sides of the Claw do not open and close together, open the Claw jaws to the maximum width, increase engine rpm, and operate Claw again. This should cause the Claw to function properly, if not, contact Tink, Inc.

Nearly all vehicles suitable for Claw use have at least two hydraulic circuits. One is used to raise and lower the lift arms and the other is used to tilt the bucket forward or back. The Claw requires one additional hydraulic circuit to operate its sidewalls and undercutting blades. This third circuit with its control valve must be on the vehicle before the hydraulic hookup to the Claw is made.

With the Claw resting on the ground, and vehicle engine off, measure the length of hose needed to connect the third hydraulic valve to the cushion valve. Be sure no one is on or near the Claw or vehicle, start the engine, and raise the Claw to its highest position. Tilt the Claw up and down and note at which position the longest hose will be needed. With the Claw at this height and position, rest the Claw on a firm platform or install safety braces so the Claw cannot drop. Turn off the vehicle engine and measure the required hose lengths. Compare these hose lengths with those measured before and make hoses for the longest lengths measured.

Be sure no one is on or near the Claw or vehicle, and lower the Claw to the ground. Be sure there is no weight of the vehicle taken by the Claw and turn off the vehicle engine. Work the hydraulic control levers back and forth to relieve any residual hydraulic pressure. Install the hoses and flow control valves (if provided). Arrows on both flow control valves should point toward the Claw.

Be sure no one is on or near the Claw or vehicle. Start the vehicle engine and raise the Claw off the ground. Tilt the Claw forward and backward to check that the hoses are long enough and do not bind. Repeat this at several different Claw heights. When it is clear that the hoses are not too long or too short, lower the Claw to the ground, turn off the engine, and move the hydraulic control levers back and forth so that residual pressure is off the hoses. Now tie the hoses to the vehicle arms so that they will not drag along the ground when the Claw and vehicle are moved. If necessary, wrap portions of the hoses to prevent chafing.

IMPORTANT:

- The sides of the Claw should open or close in two to three seconds with the engine at operating speed. Flow control valves are installed to restrict flow in the event the vehicle's hydraulic system puts out more flow than is required.
- If opening and closing times do not meet requirements, contact Tink, Inc. for assistance.
- Never let the walls slam open or shut; this will cause damage to the Claw.
- When flow control valves are properly adjusted, the hydraulic system is complete.

This completes the installation of the Claw on the vehicle.

OPERATION

The Claw mounts on a wheel loader, an industrial tractor, a backhoe-loader or a similar vehicle. As the sidewalls squeeze together the bottom blades slip under the material. The pile is thus undercut and retained by the box of the closed Claw. Additionally, material extending beyond the front of the sidewalls is grasped by the vertical front edge of the sidewalls and the teeth attached thereto. Thus, long branches can also be picked up by the Claw. The load is discharged by tilting the Claw forward and opening the sidewalls. The material will slide out by gravity.

The Claw should always be gently lowered (rather than dropped) to the ground when preparing to pick up a pile. When on the ground, the Claw should have its weight distributed evenly between front and back and one side to another. Do not add the weight of the vehicle to the Claw as this will cause excessive wear and possibly structural damage. Care in using the Claw will minimize cracking or shattering of the wear surfaces and will extend the life of the bearings.

To minimize wear on the bottom blades, keep the Claw off the ground except when actually picking up a pile. When thrusting forward to encircle a pile and when the sides are being closed, the Claw should rest only lightly on the street or ground surface. If two piles are to be picked up as one load, lift the Claw between the two piles. If the Claw containing the first pile is opened above the second pile, the fallout from opening will fall on the second pile, and total pickup will be clean. With practice, the operator will begin to use the Claw as an extension of his hand and will be able to pick up and discharge materials as he would grasp things with his thumb and fingers.

MAINTENANCE DETERRENTS

The Claw was designed and built to require minimum maintenance. The wear surfaces are replaceable with an impact wrench or minimal welding and all bushings are provided with grease fittings. The Claw is used in streets where it is often skidded forward on the asphalt. This inevitably causes wear. However, wear areas have been provided to control this wear and to reduce the maintenance associated with it. Hardened steel blades are used as cutting edges on the bottoms of the sides. These can be replaced using an impact wrench. Minimum maintenance will result if the following four basics are followed by the owner:

MOUNT CLAW PROPERLY

The weight of the Claw and its load should be evenly distributed front to rear and side to side. In order to assure that this will be the case, the Claw must be mounted on the loader and checked for proper bearing on flat surface. If the vehicle, to which it is attached, has a self-leveling feature, this must be properly adjusted. Follow the vehicle information in making this adjustment.

ADJUST CLAW PROPERLY

The lower surfaces of the blades and wear shoes are lower than the bottoms of the sides on a new Claw. This gives ample room for wear as the tungsten carbide and steel is consumed. The tungsten carbide has approximately ¼ inch of useful thickness. Be sure that the bottoms have not been bent. Inspect, and if this has happened, bend them up again to overcome this difficulty. In some cases the road on which the Claw travels is highly crowned. There is no adjustment for this except to install shims between the blades or wear shoes and the surface to which they attach.

OPERATE CLAW PROPERLY

In operation, care should be taken to lower the Claw only far enough to reach the ground. There should be no attempt to force it into the pavement; this will put some of the vehicle weight on the Claw and cause rapid wear. In addition, the Claw should be on the ground only when actually picking up. It should not be skidded along the pavement for long distances. Nor, should it be “dragged” against curbing except when necessary to pick up material that is piled against the curb. Finally, the blades should be supported on the bottom by a firm surface, such as a roadway, when undercutting material. This will assist in preventing the blades from being bent downwards if they should attempt to grasp an object such as a rock, timber, etc.

INSPECT CLAW DAILY FOR ABRASIVE WEAR

Wear Surfaces

Inspect to be sure the retaining bolts on blades are tight. Tighten if necessary after applying a medium strength anaerobic locking compound. As the tungsten carbide is consumed, shim the wear shoes. When all tungsten carbide is gone, replace the blades or wear shoes so abrasive wear will not be transferred to structural parts of the Claw.

Bearings

There are solid steel bearings at each of the cylinder pivots and in the hinges. All are provided with grease fittings. Lubricant once weekly, more often if working under wet or dusty conditions. Even with such maintenance the bushings will eventually pound out. Check for such wear weekly and replace promptly to preserve the overall life of the Claw.

Hydraulics

Do not let the hoses become worn, pinched, or kinked. Leaks at the hydraulic cylinder require standard cylinder maintenance procedures-replacement of seals and/or rings and refinishing or replacing the piston rod if it gets scored. Hydraulic fluid must be clean. If it is not, excessive wear of the compound will be experienced and the flow divider will fail to operate properly.

Safety Labels

OSHA type Caution decals are placed on the outside of the Claw, visible when the blades are open or closed. Even though these decals are Mylar coated for abrasion resistance, with time they will become scratched and marred. Clean or replace the decals when they are no longer easy to read.

Parts Damage

Actual damage to the Claw may occur; hitting an obstruction when picking up scattered material is the most likely cause. Claws that discharge into garbage trucks get their framework and/or skin dented, but this is not usually serious. Structural damage-twisting or bending of the blades, sidewalls, or back wall frame is serious and parts need to be repaired or replaced promptly. A parts list and parts drawing is included in this manual. Specify the Claw model and serial number when ordering parts.

REPLACEMENT PARTS

Refer to the following illustrations and lists for replacement parts for Claws. Always give Serial # and Model # of Claw when placing an order.

720 CLAW PARTS LIST

ITEM	PART #	DESCRIPTION	QTY
1	601720	Back frame, 720 claw	1
2	690240	Jaw assembly, left side 720 claw	1
3	690245	Jaw assembly, right side 720 claw	1
4	2005773	Blade, 720 claw	2
5	2005680	Cylinder, 4 x 8	2
6	814640	Hinge pin, 720 claw	2
7	814350	Pin, cylinder rod end	2
8	814360	Pin, cylinder base end	2
9	2002174	Bushing, brass 1-3/4 x 1-1/2 x 2-1/4	12
10	2002098	Thrust washer, 720 claw hinge	12
11	2000764	Bolt, 5/16 nc x 1/13*	4
12	2000849	Bolt, 3/8 nc x 3*	2
13	2001383	Plow Bolt, 1/2 nc x 1-1/2 (blade fastener)	6
14	2001384	Plow Bolt, 1/2 nc x 1-3/4 (blade fastener)	20
15	2001643	Locknut, 5/16 nc*	4
16	2001646	Locknut, 1/2 nc (blade fastener)*	22
17	600720L	Left Hinge assembly, 720 claw	2
17	600720R	Right Hinge assembly, 720 claw*	2
18	813140	Blade mount, (weld-on) 720 claw	2
19	812120	Jaw teeth (Specify left or right)	2
20	600680	Floor assembly, (Specify left or right) 720	2
21	812160	claw Cylinder lug, front 720 claw	4
22	812170	Cylinder lug, rear 720 claw	4
23	814680	Pin Retainer, boss bushing 520/720 claw	4

*Not pictured.

ILLUSTRATION 720 CLAW PARTS LIST

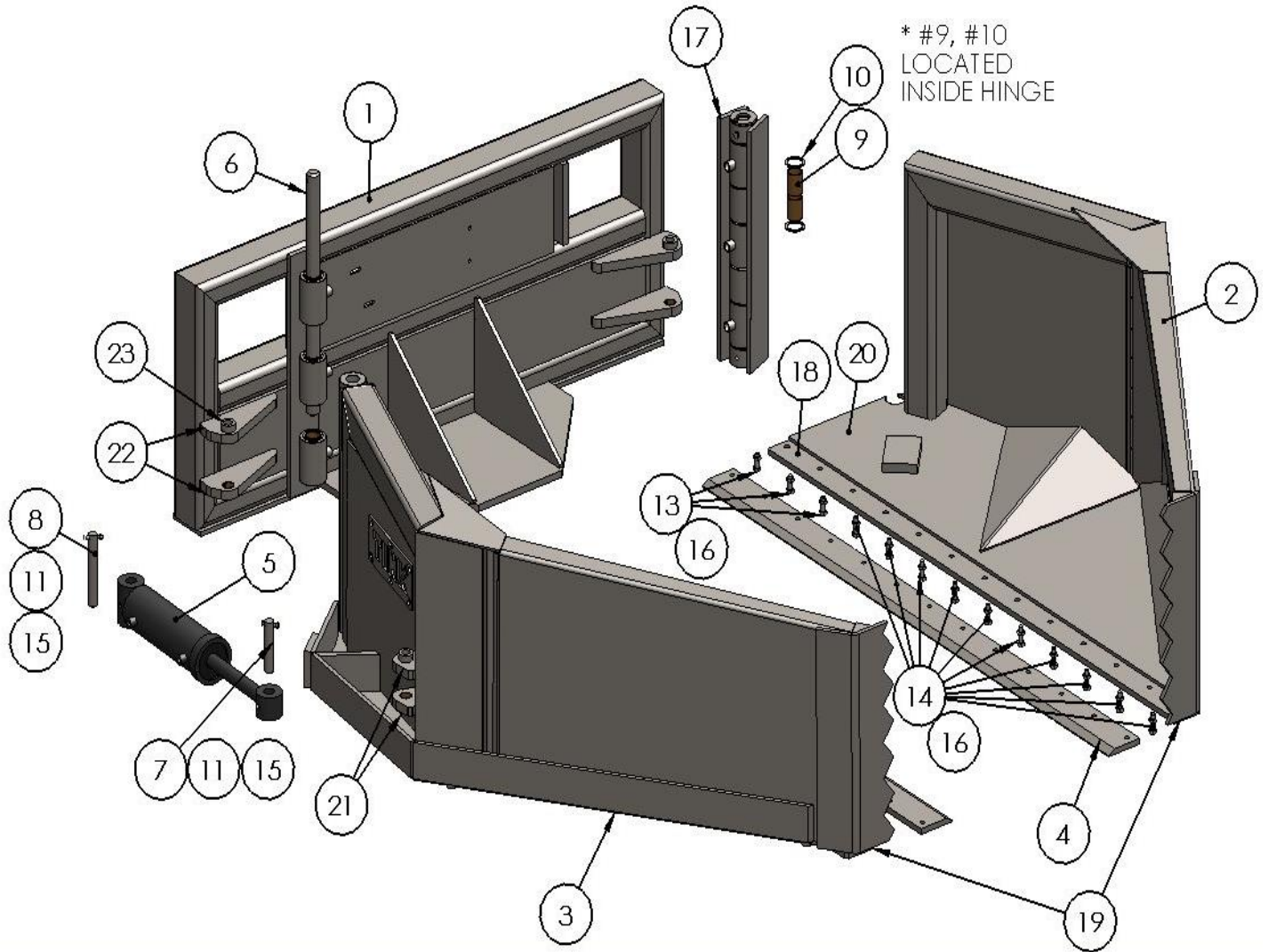

720 CLAW CYLINDER PARTS LIST

ITEM	PART #	DESCRIPTION	QTY
1	2004169	Barrel assembly, 4 x 8 Cylinder	1
2	2005942	Locknut, 3x and 4 x 8 Cylinder	1
3	2004170	Rod assembly, 4 x 8 Cylinder	1
4	2005722	Gland collar, 4"	1
5	2004167	Basehead, 4 x 8 Cylinder	1
6	2004166	Piston, 4 x 8 Cylinder	1
7	2004247T*	Seal kit, 4 x 8 Cylinder	1
8	2002144*	Brass Bushing (2 in Rod End / 4 in Base End)	6

*Not pictured.

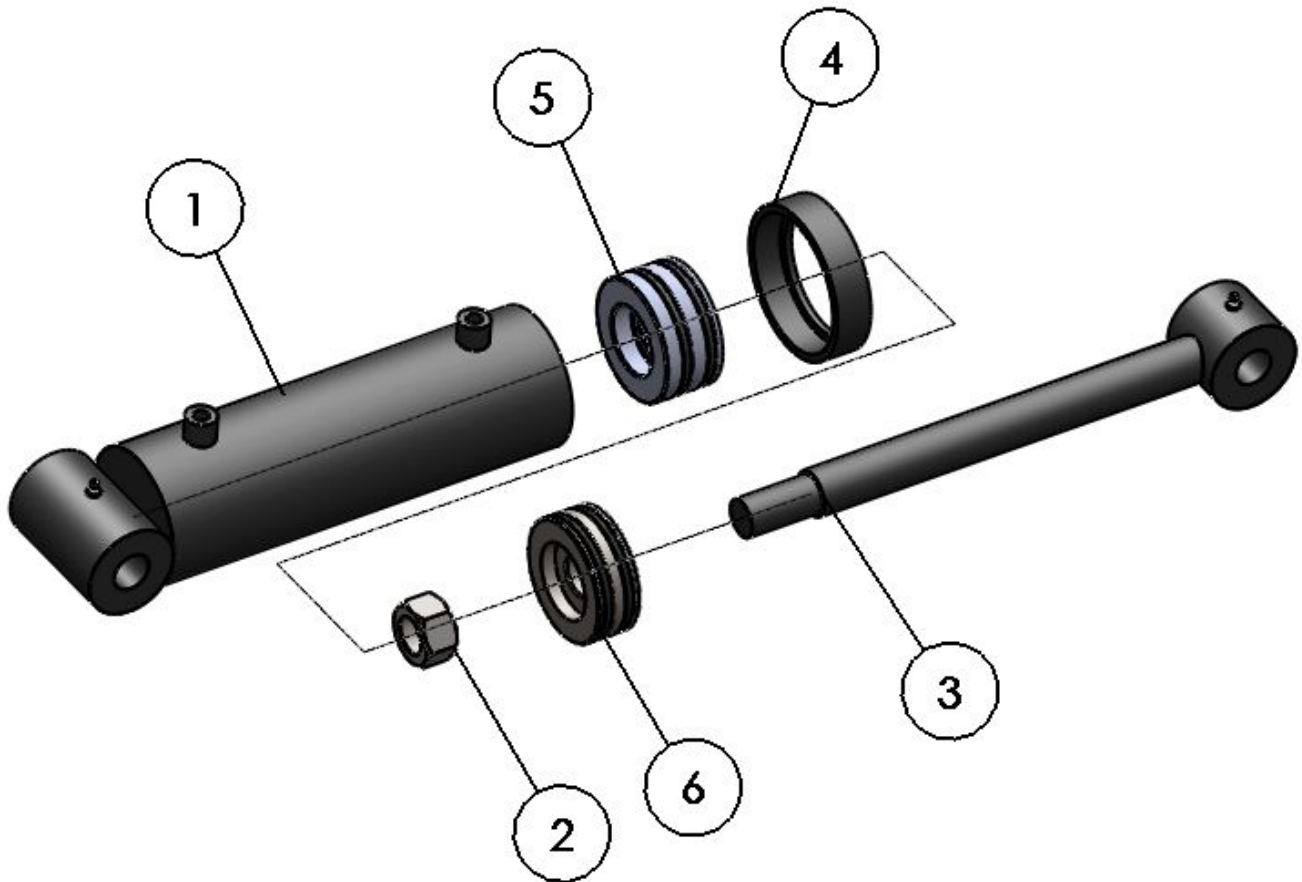

WARRANTY

Warranty Policy

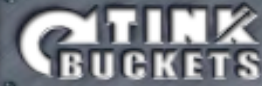

Questions About a Warranty? *CALL US FIRST!*

You must contact Tink for warranty consideration. Failure to do so may void warranty. We like a “no surprises” approach when handling warranty claims. If a problem or failure occurs, please contact us immediately. Talking to one of our experts in the parts and services department will ensure that all parties know what to expect.

Tink's Guarantee

Tink, Inc. products are guaranteed against failure due to defective design, workmanship or materials for a period of 1 year or 2,000 hours, whichever comes first, from date of delivery to purchaser as validated by the **completed and returned warranty registration form**. If Tink, Inc. finds, upon physical inspection of product or product components returned freight unpaid, and/or upon review of warranty claim including **photos** of alleged defects noting that warranted products are defective in design, material or workmanship, such products will be, at Tink's option, replaced or repaired.

Authorization

All warranty work and returns must be authorized by Tink, Inc. prior to any work being performed or returns made. If the end user, dealer, or other entity performs work or makes a return without authorization he does so with the understanding that Tink, Inc. shall not be obligated for the costs of any such unauthorized expense or actions. The purchaser of any products covered by this warranty understands and agrees that the sole and exclusive remedy against Tink, Inc. shall be for the replacement or repair of defective products as provided herein. All allowances will be paid at dealer cost with no provi-

sions for overtime, mileage, freight charges, special services, downtime or loss of machine productivity. Dealer shop rate charges on approved repairs shall not exceed 70% of hourly rate.

Exclusions

Tink, Inc. warranty is not extended or applied to:

- Failures, which in Tink's judgement are the result of misuse, negligence, accidents, improper installation, or failure to perform regular maintenance.
- Products or component parts not manufactured by Tink. Such items are subject to OEM's warranty, if any, of the respected manufacturer.
- Products improperly installed, maintained, or used not in accordance with all applicable Tink instructions.
- Products or components that are modified or changed in any way without written consent.
- Parts typically considered as wear items.
- Failure of product placed in an application for which it is not intended.
- Parts or product damage caused as a direct result of improper and/or untimely repair procedures.

If You Discover a Problem...

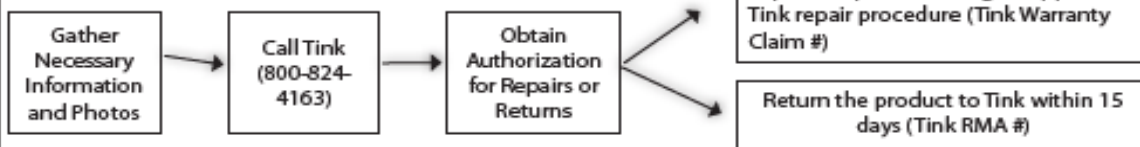

TINK, Inc. • 2361 Durham Dayton Highway • Durham, CA 95938 • www.tinkinc.com

CALL TOLL FREE 800-824-4163



Policy Procedure

Call Us

Upon discovery of a product or failure on a Tink product that is within the warranty period, please call the Tink Service Department immediately (800-824-4163). Please inform the Tink representative that you consider the problem/failure to be eligible for warranty. Be prepared to provide Tink with the following information:

- Serial Number of the Tink product (see page 12)
- Part number, date purchased, date installed and hours of use (number of hours on prime mover if applicable)
- Prime mover machine brand and model information, and machine serial number
- Description of specific component failure
- Clear, focused photos of problem area (see next page)
- End user comments pertaining to the failure

NOTE: Any warranty claims by the purchaser not submitted to Tink within 30 days following the date the failure was discovered, or by reasonable inspection should have been discovered, will not be covered by this warranty.

Repairs/Warranty

If a defective product or component can be repaired at your location or in the field, Tink will instruct you regarding the approved repair procedures and issue a warranty claim number authorizing you to make those repairs. Flat rate hours will be quoted by the Tink service department for any repair judged to require more than two hours to complete. If problems occur that were not originally addressed, Tink must be contacted to authorize any additional labor hours. Tink cannot be responsible for work performed without prior notification.

Upon completion of the repair the warranty claim must include:

- A completed Tink Warranty Claim Form accompanied by a copy of the dealers service ticket. Claim must include a detailed description of the failure.

- Itemized list of parts used (part number, description, unit cost, quantity)
- Itemized breakdown of labor hours claimed (operation performed and time)
- Photographs showing the areas of failure and general condition of the Tink product (see page 15)

Returns

A Return Merchandise Authorization (RMA) number will be issued if it is deemed necessary to return the defective product or component to Tink for repairs or warranty evaluation. All shipping documents must show this number.

If the repair requires Tink parts you must refer to the Tink Warranty Claim Number when ordering those parts. Each replacement part will be shipped with a RMA number tag authorizing you to return the defective parts to Tink. Place the RMA tag on the defective part and ship prepaid to Tink within 15 days. All shipping documents must show this number or the part will be returned to you freight collect.

NOTE: Made-To-Order Products cannot be returned. Products Authorized for Return by Tink, Inc. are subject to a restocking charge of 25% of net price. The product will be inspected at Tink and upon acceptance the appropriate credit will be issued. Under no circumstances will credit be issued for a used product. Failure to ship defective part(s) to Tink within 15 days for evaluation will result in the cancellation of the warranty claim.

Freight/Freight Estimates

Outbound Freight is F.O.B. Durham, CA unless otherwise specified in writing. Tink will arrange shipping for the least cost and fastest service. Rates provided by Tink are estimates and only guaranteed if Tink, Inc. invoices customers with approved credit status for the freight charges.

Inbound Freight marked with the appropriate RMA number will only be accepted if the freight has been prepaid unless otherwise specified in writing.

TINK, Inc. • 2361 Durham Dayton Highway • Durham, CA 95938 • www.tinkinc.com

CALL TOLL FREE 800-824-4163

Picture Taking Guide



Tink, Inc. is dedicated to the continuous improvement of our product. We thank you for submitting clear and accurate pictures of the defect or failure to assist in the evolution of future Tink buckets.

When submitting a request for warranty consideration, **Tink requires photos of the entire bucket as well as close-up photos of the problem area.** Please include the following pictures:



Serial Number



Right Profile with Cutting Edge



Subframe



Side View of Subframes and Hooks



Left Profile with Cutting Edge



Close Up of Cutting Edge



3/4 View of Bucket



Bottom of Cutting Edge



When taking overall photos, use the landscape setting of your camera.



When taking detailed photos of the problem area, use the macro setting.

Note: avoid using flash if possible.

TINK, Inc. • 2361 Durham Dayton Highway • Durham, CA 95938 • www.tinkinc.com

CALL TOLL FREE 800-824-4163