

CARSON'S COATINGS

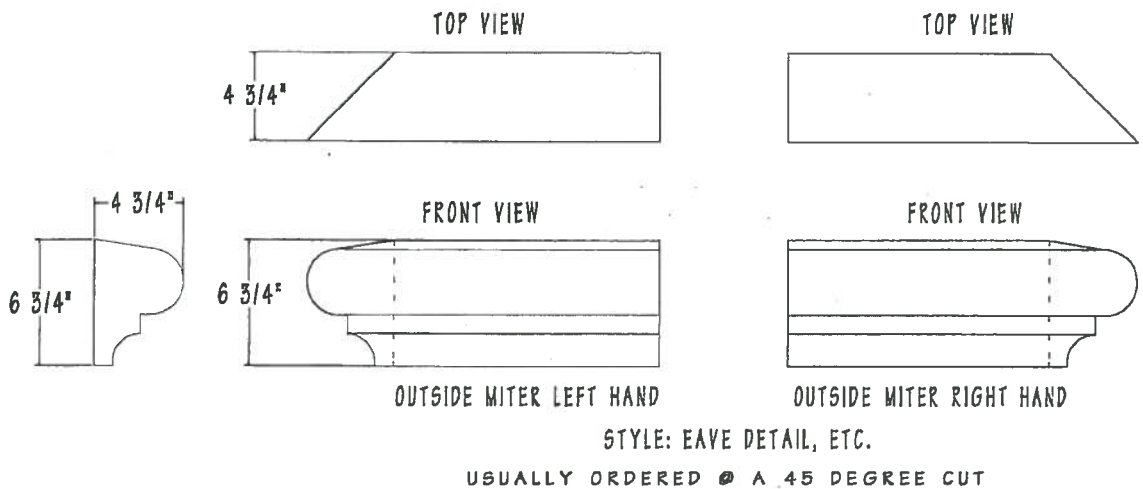

WWW.CARSONSCOATINGS.COM

CARSON'S COATINGS MITERING REFERENCE TERMS HELPFUL ORDERING GUIDE

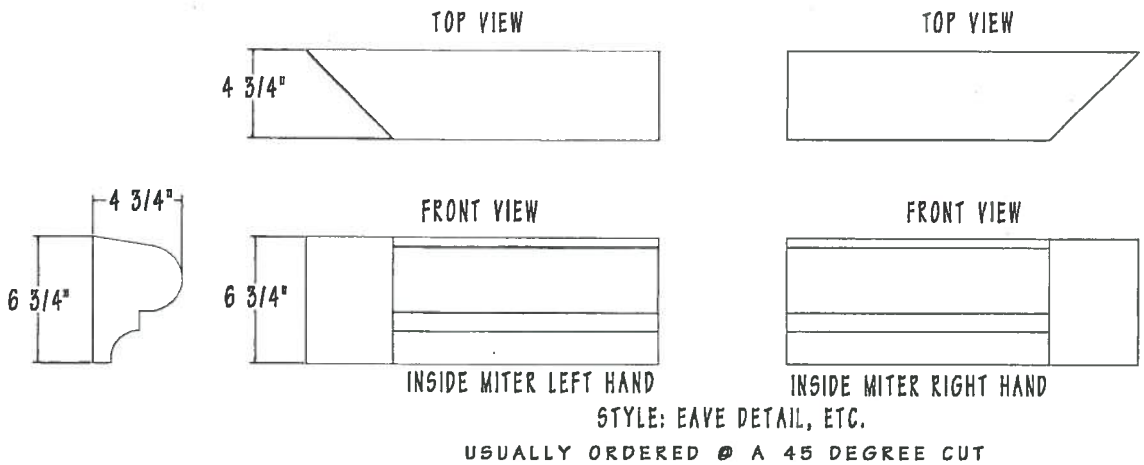
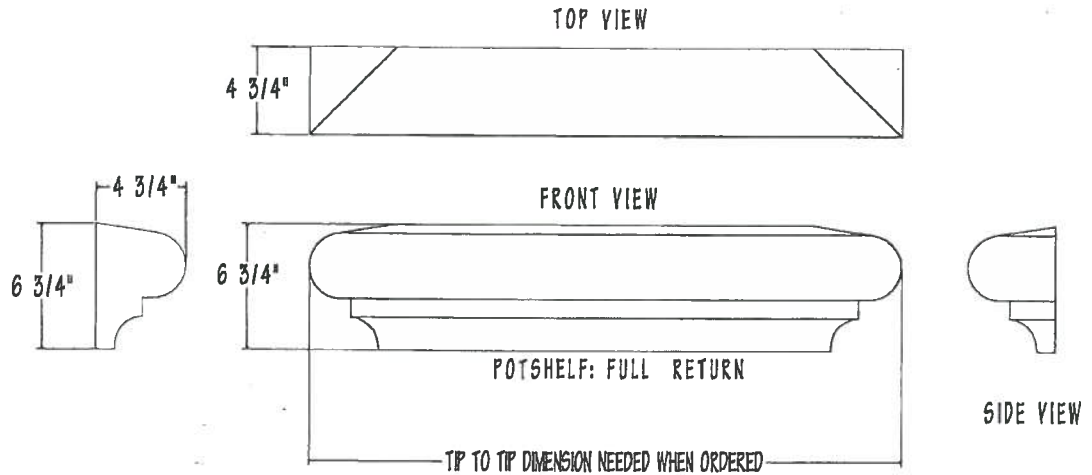

CARSON'S COATINGS
 MITERING REFERENCE TERMS
 HELPFUL ORDERING GUIDE

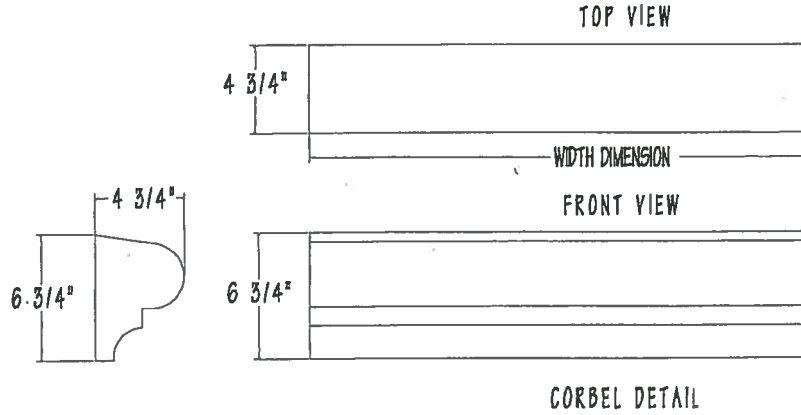

ENDS USUALLY COATED
 ON CORBELS UNLESS OTHERWISE
 SPECIFIED WHEN ORDERED

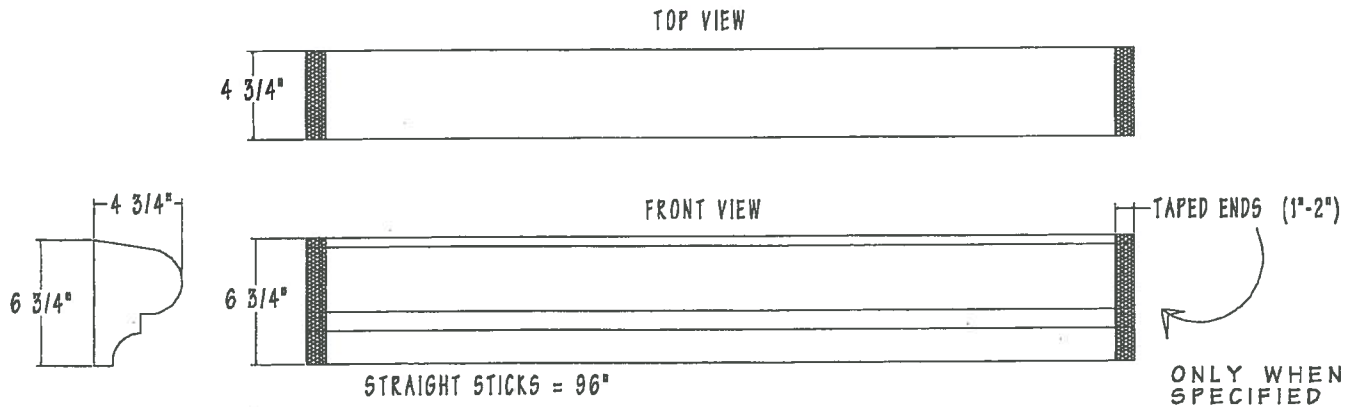
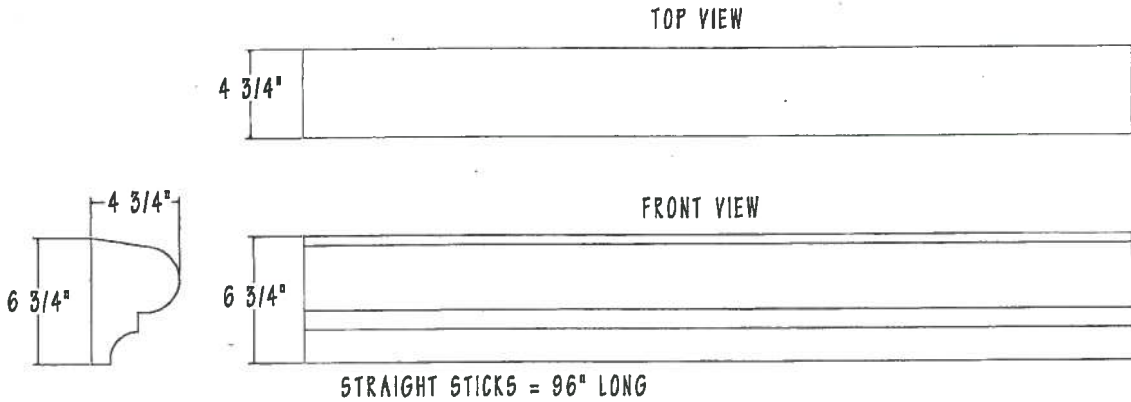

ONLY WHEN
 SPECIFIED

CARSON'S COATINGS
 MITERING REFERENCE TERMS
 HELPFUL ORDERING GUIDE

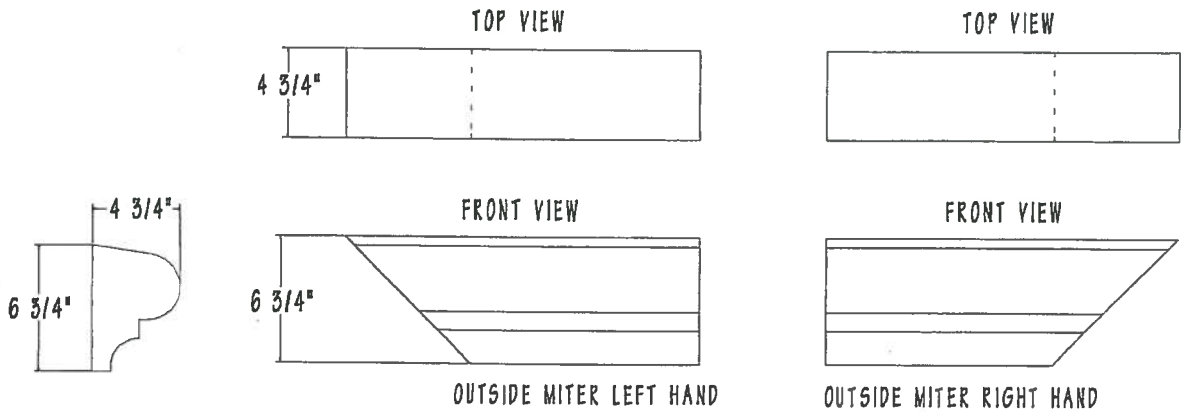

STYLE: WINDOW SURROUND

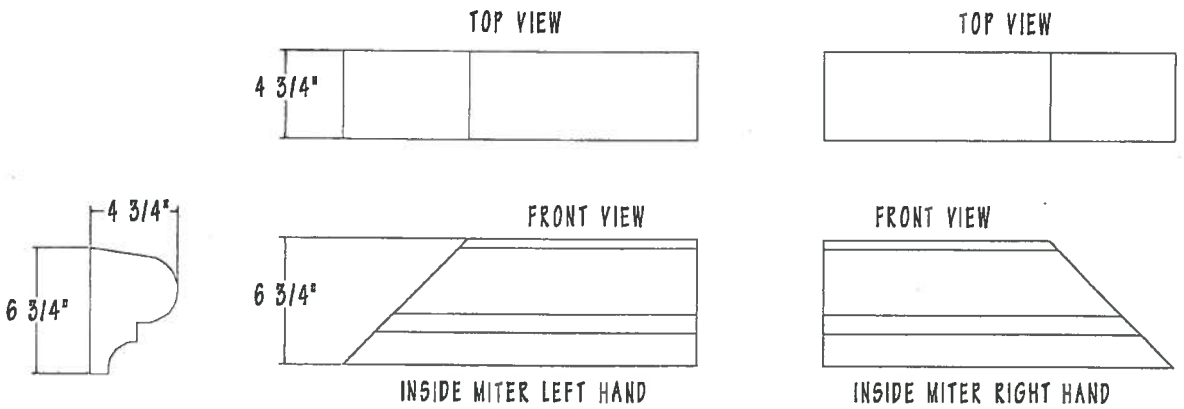

STYLE: WINDOW SURROUND

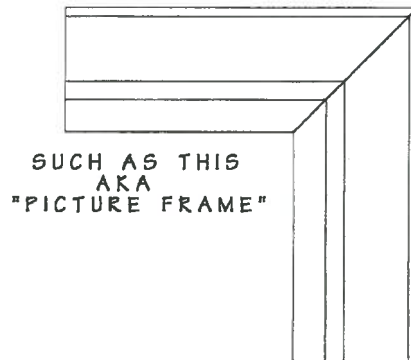

CARSON'S COATINGS
 MITERING REFERENCE TERMS
 HELPFUL ORDERING GUIDE

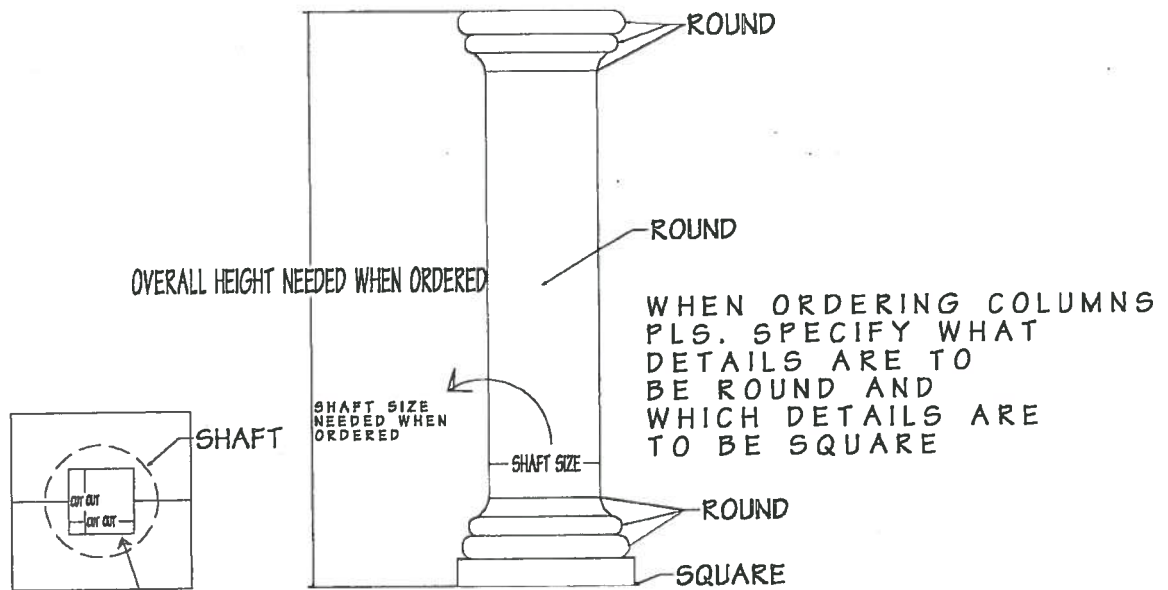

SPECIFY CUT OUT
 WHEN ORDERING
 SUCH AS...
 CUT IN HALVES
 SOLID W/ CUT OUT
 SOLID NO CUT OUT
 ETC.

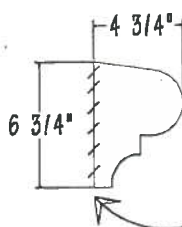

'NETTING PATTERN' = SPECIFIES WHERE THE SHAPE WILL BE COATED & ALSO WHERE IT IS NOT TO BE COATED.

THIS IS SPECIFIED ON THE DRAWING BY SLASHES WHICH ARE PLACED ON THE SIDE (DIMENSION) WHICH IS NOT TO BE COATED.

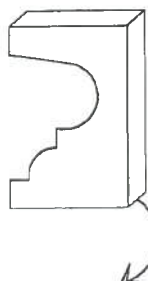

'GUIDES' = A MACHINE CUT NEGATIVE OF ANY SPECIFIC SHAPE OR DETAIL USED TO ASSIST IN ALL ASPECTS OF COATING IN HOUSE AND IN THE FIELD.

GUIDES CAN BE ORDERED/REQUESTED WITH ALL ORDERS. PLS. FEEL FREE TO CALL OUR OFFICE IF FURTHER ASSISTANCE IS DESIRED.

STD. 2" THICK

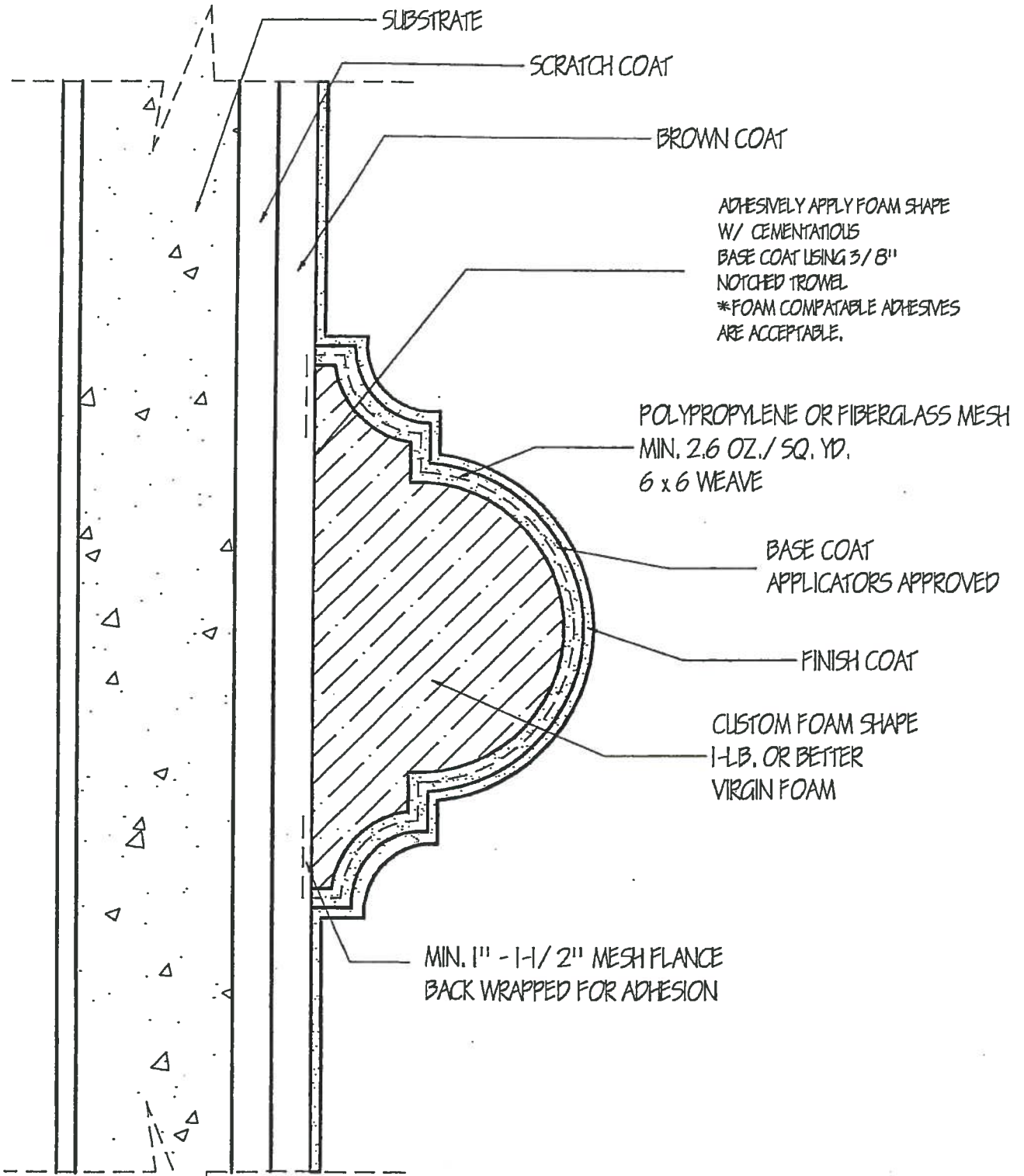

ADHESIVELY APPLY FOAM SHAPE
 W/ CEMENTATIONOUS
 BASE COAT USING 3/8"
 NOTCHED TROWEL
 *FOAM COMPATABLE ADHESIVES
 ARE ACCEPTABLE.

POLYPROPYLENE OR FIBERGLASS MESH
 MIN. 2.6 OZ./ SQ. YD.
 6 x 6 WEAVE

BASE COAT
 APPLICATORS APPROVED

FINISH COAT

CUSTOM FOAM SHAPE
 1-LB. OR BETTER
 VIRGIN FOAM

MIN. 1" - 1-1/2" MESH FLANGE
 BACK WRAPPED FOR ADHESION

RECOMMENDED STANDARD FOR APPLICATION
 OF ARCHITECTURAL FOAM SHAPES

A SHUTTER 1

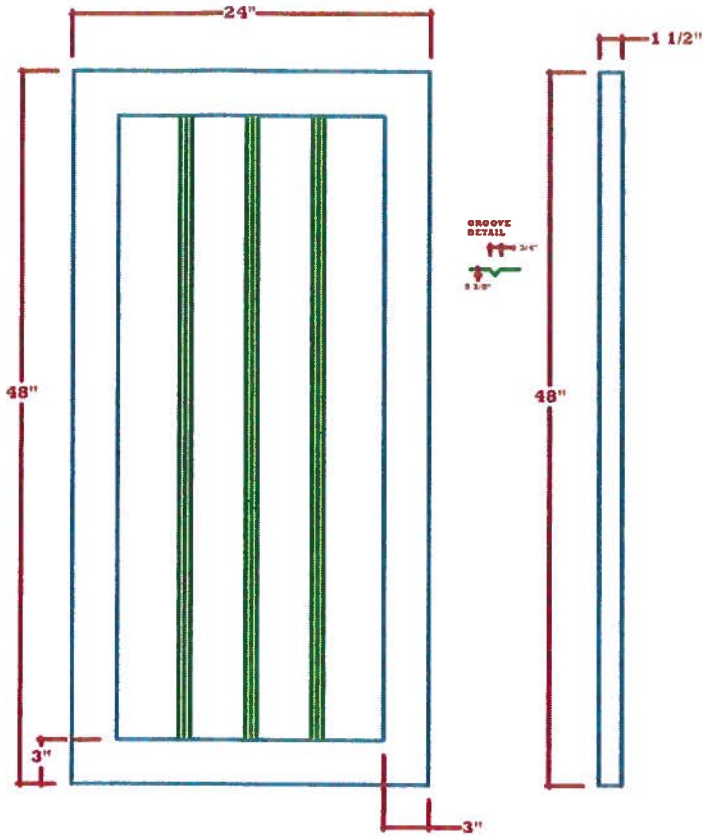

A SHUTTER 2

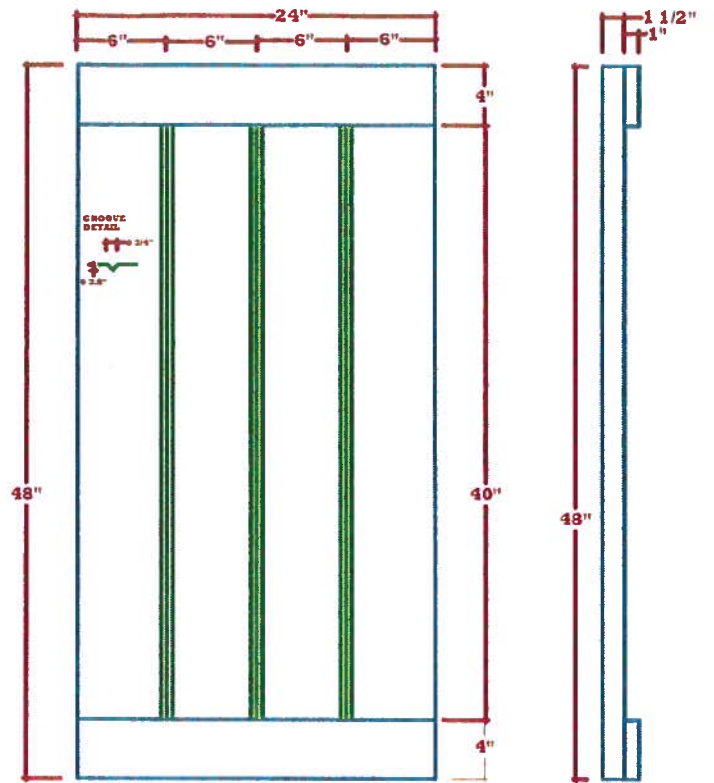

A SHUTTER 3

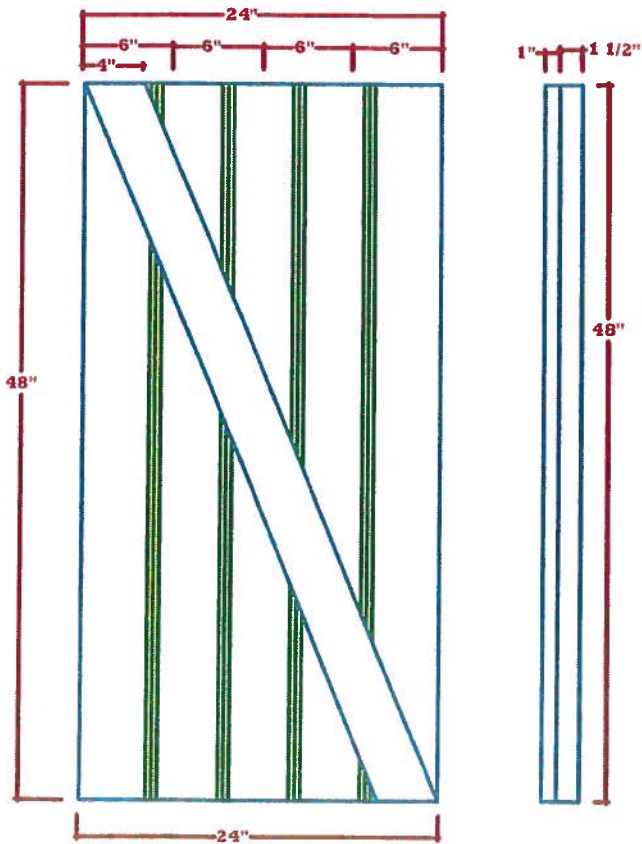

A SHUTTER 4

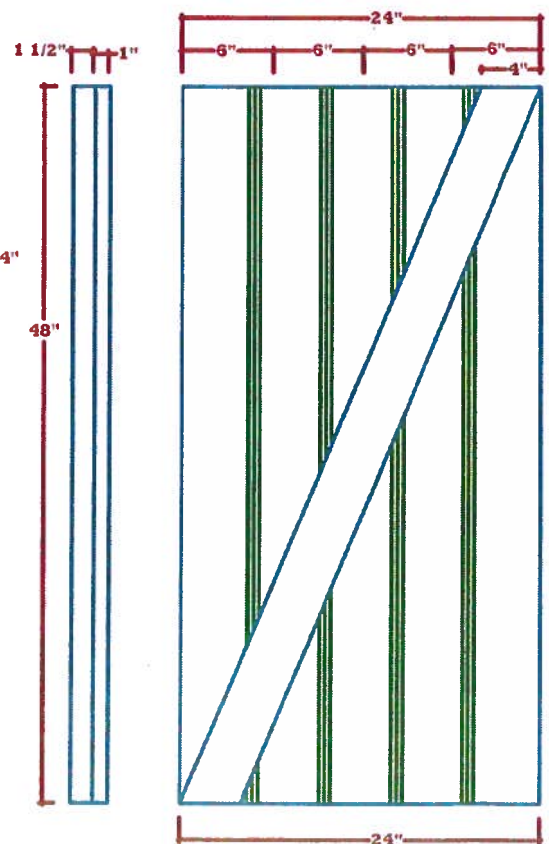

A SHUTTER 5

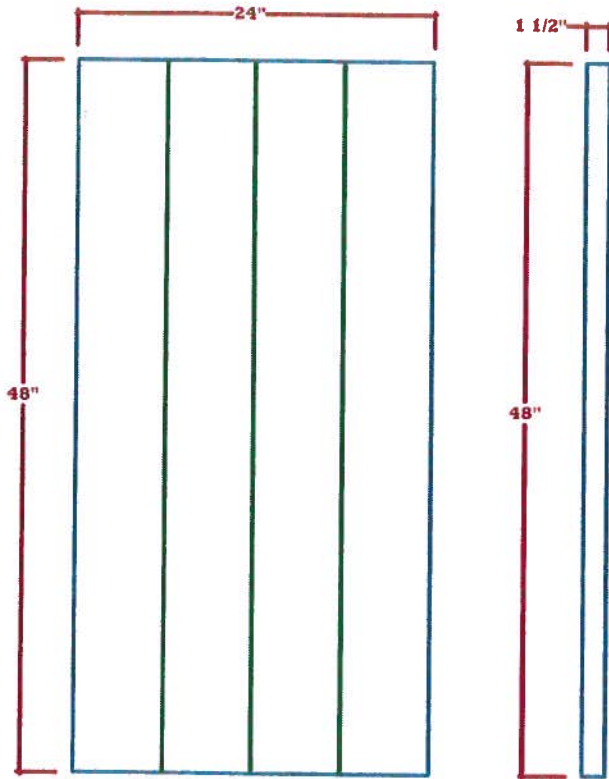

A SHUTTER 6

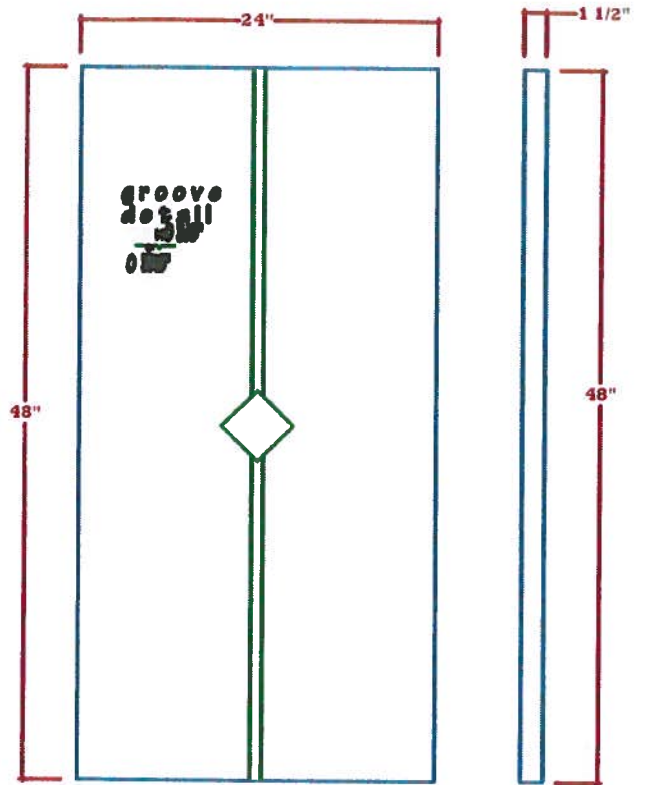

A SHUTTER 7

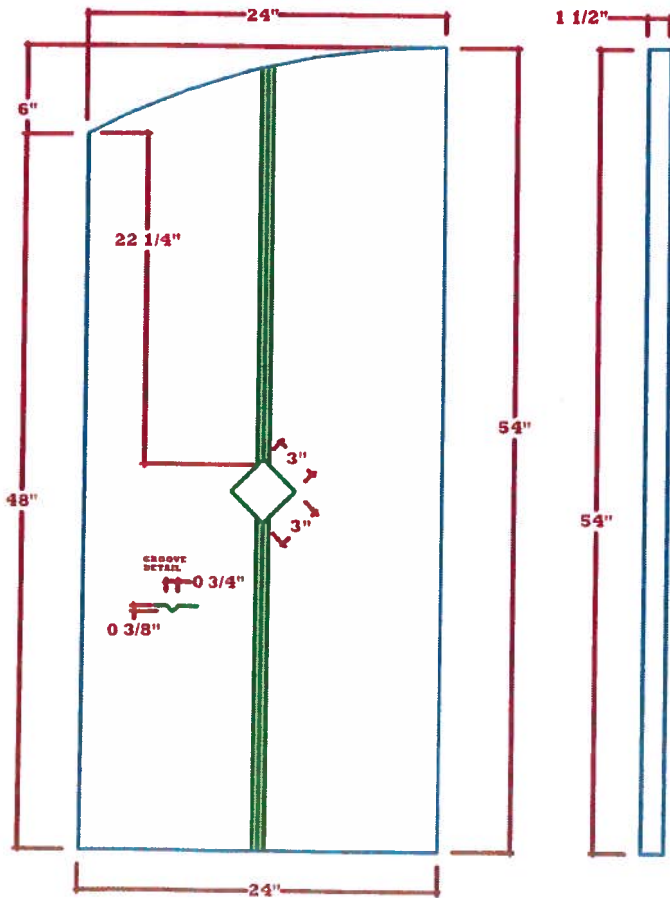

A SHUTTER 8

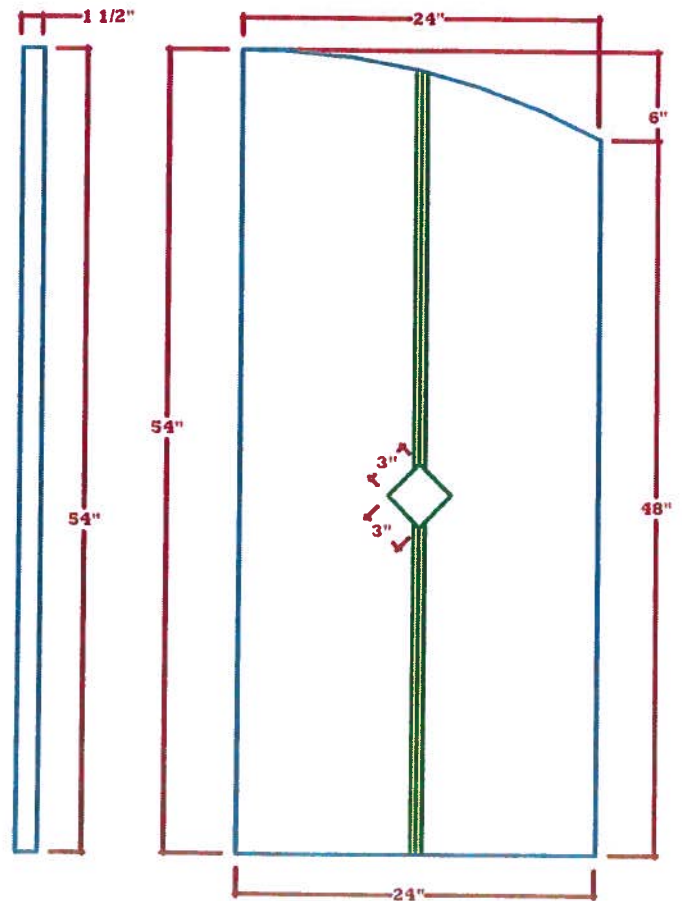

A SHUTTER 10

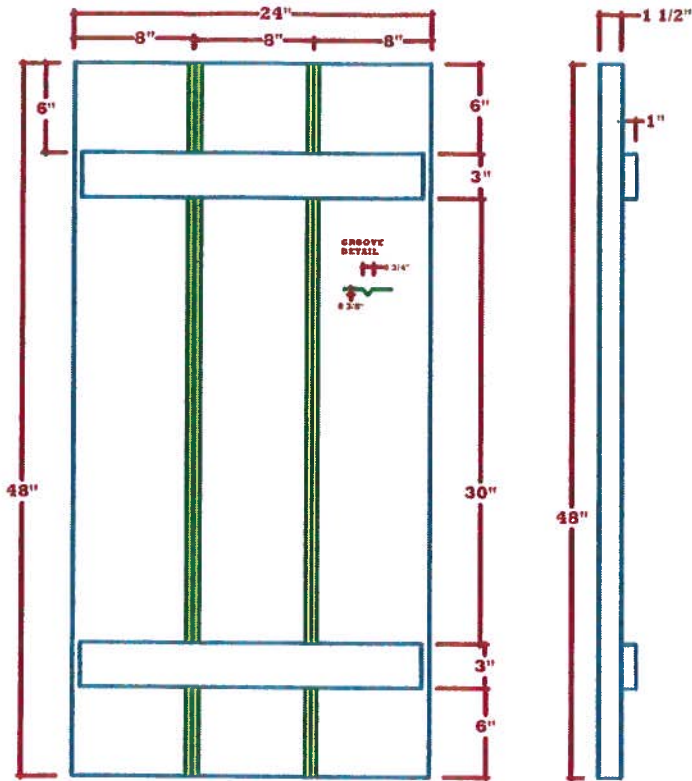

A SHUTTER 11

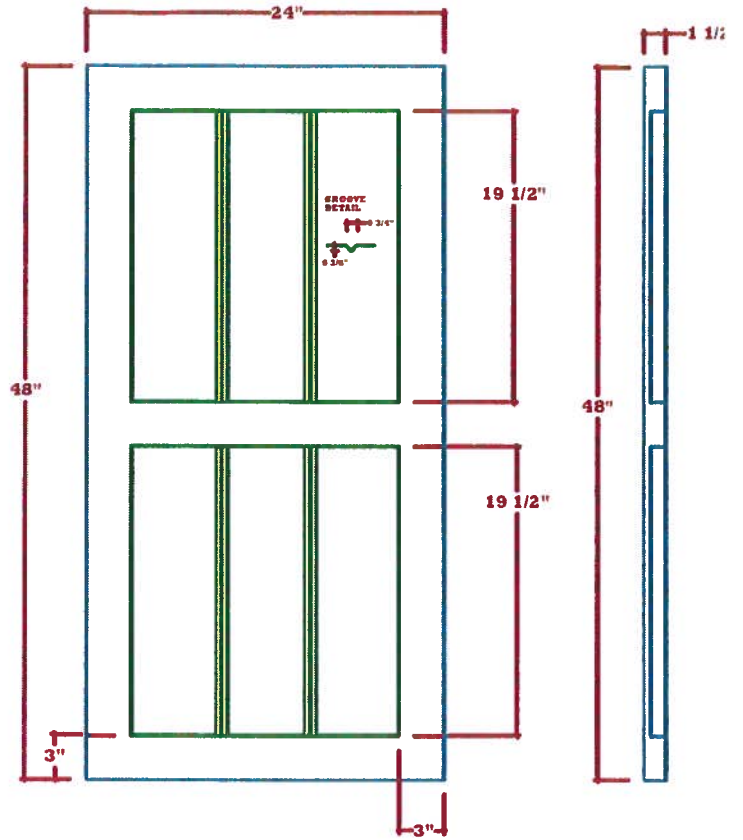

A SHUTTER 12

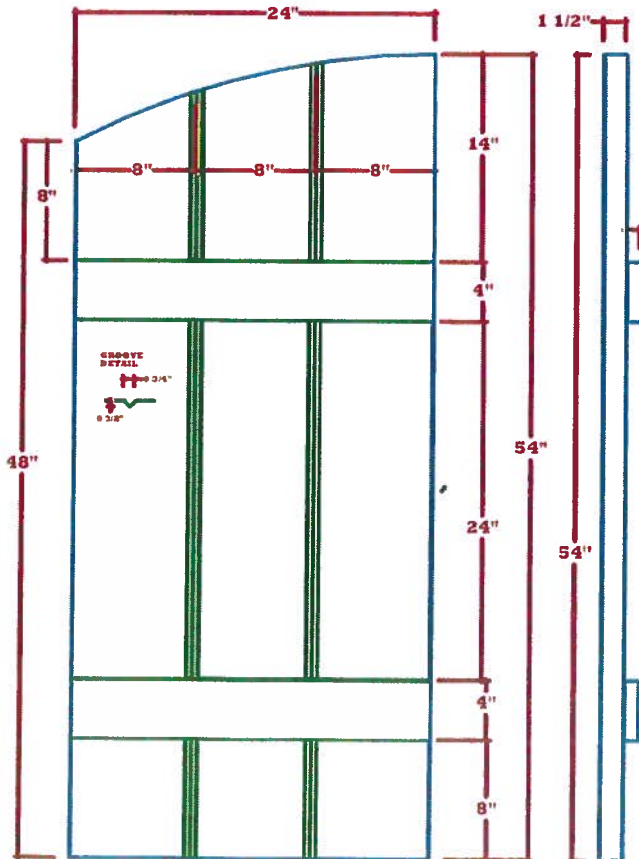

A SHUTTER 13

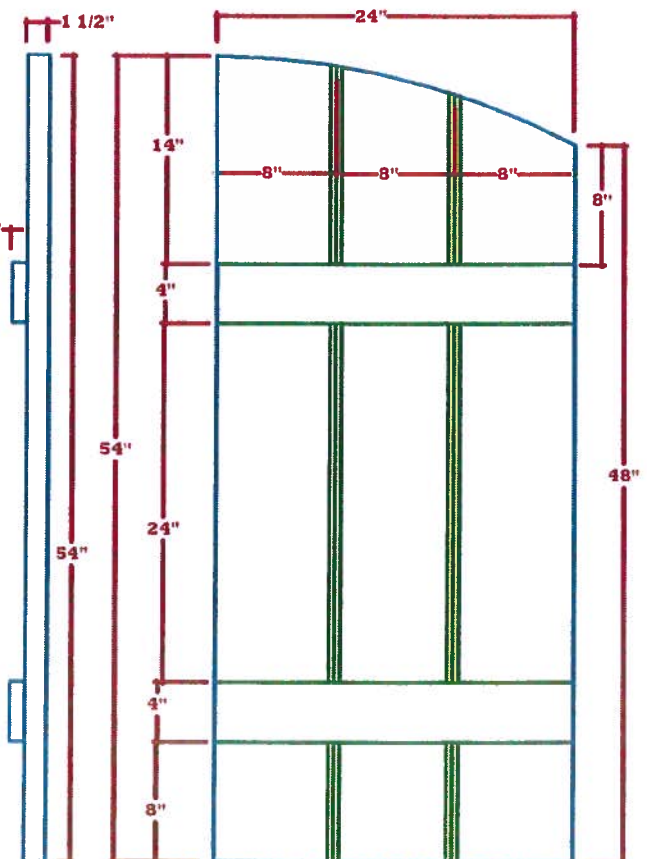

A SHUTTER 14

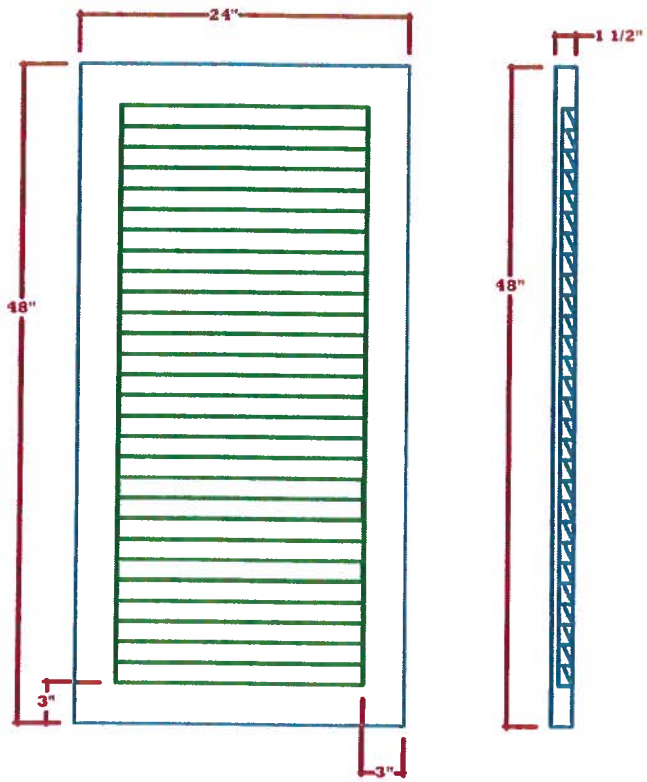

A SHUTTER 15

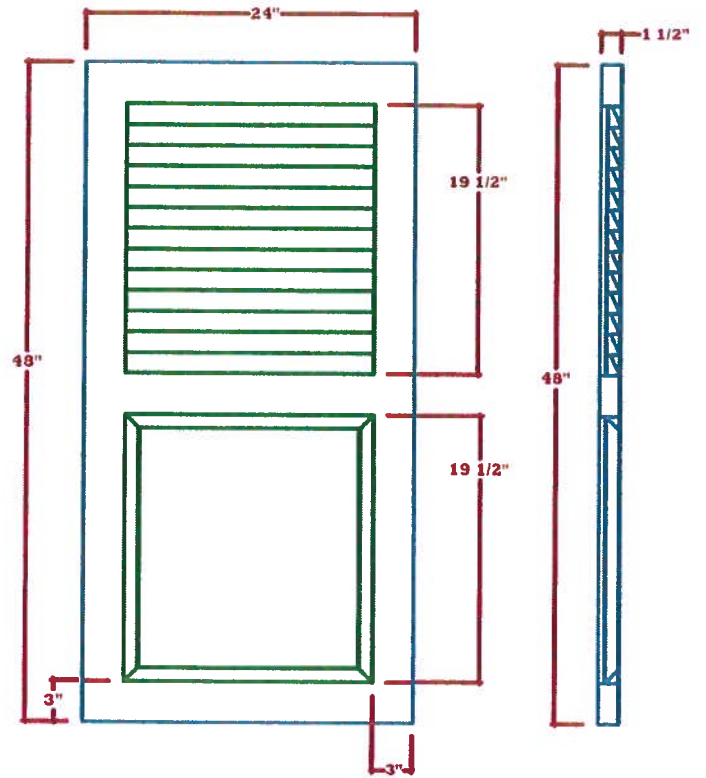

A SHUTTER 16

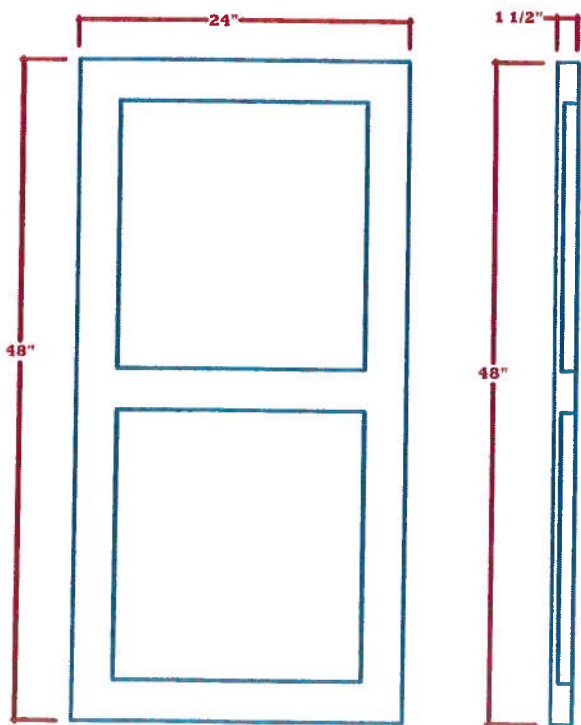

A SHUTTER 17

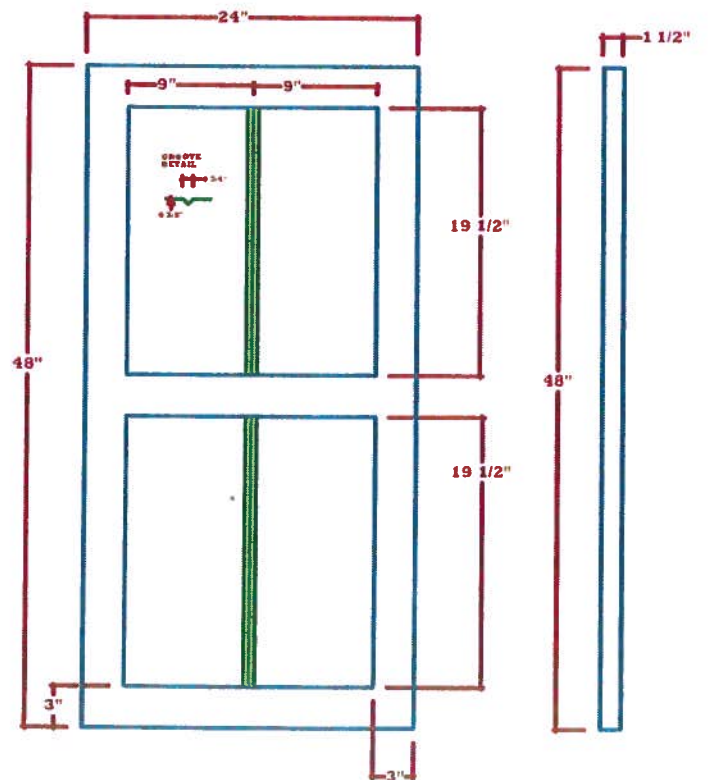

Board & Batt

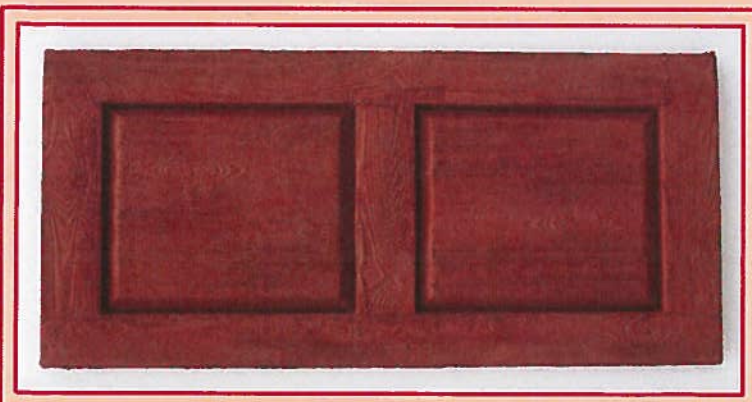

Louvered

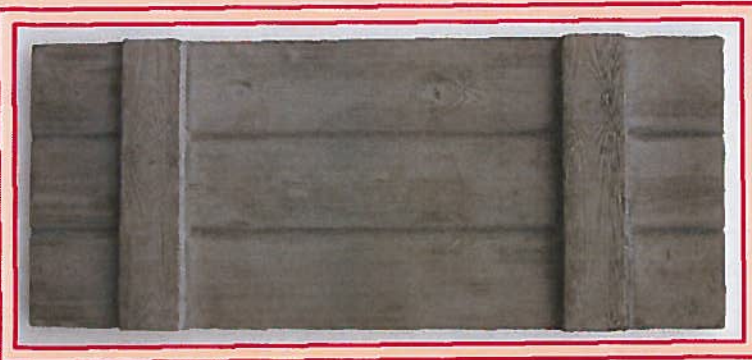

Split Louvered

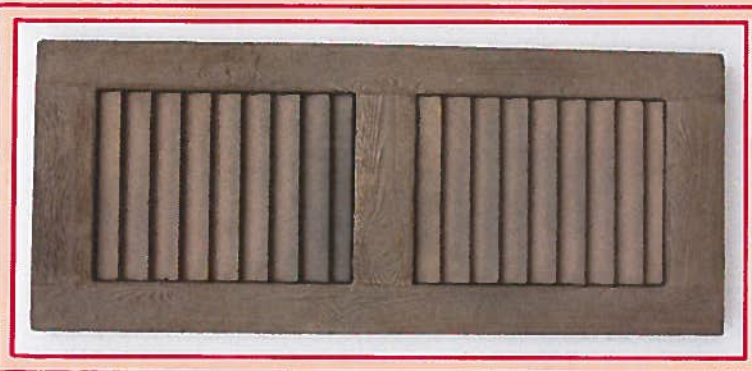

Raised Panel

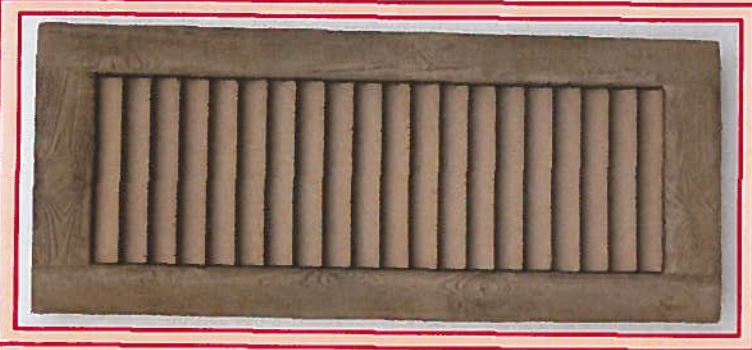

Carson's Coatings Faux Wood Shutters

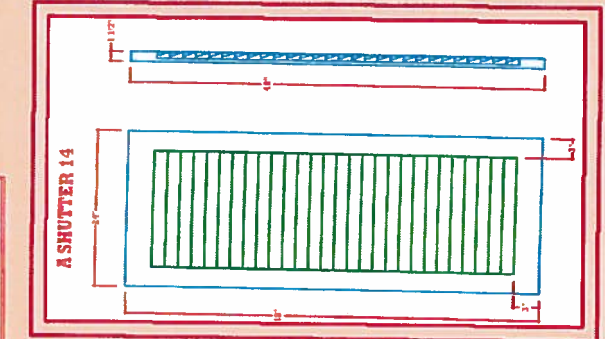
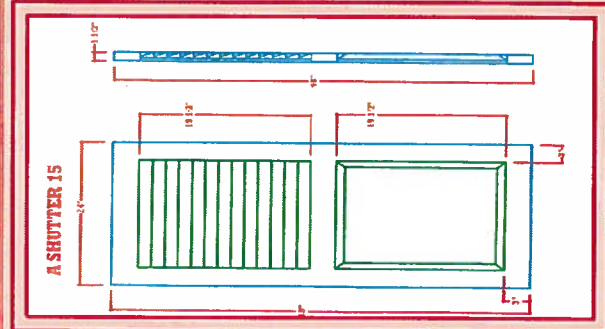
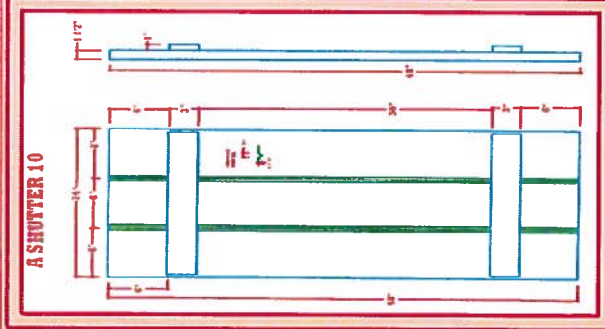
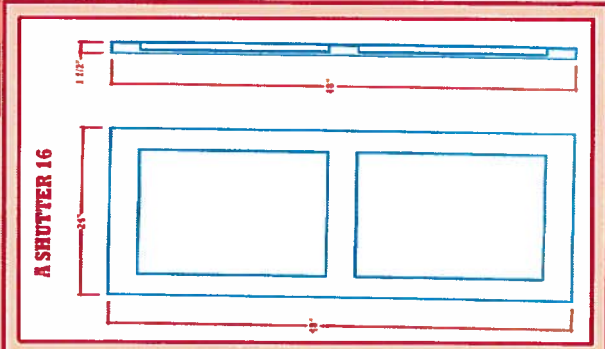

Carson's Coatings Faux -Wood Shutters

Louvered

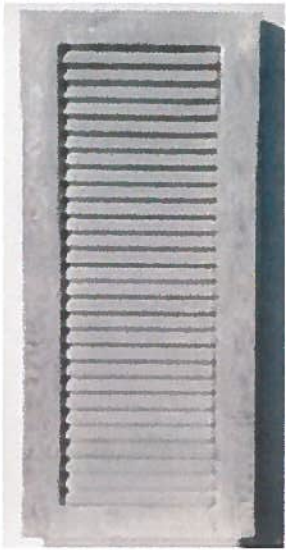

Split Louvered



Board & Bat



550 Industrial Drive Ste 200 Galt, CA 95632(209) 745-2387 Phone (209) 745-5894 Fax www.carsoncoatings.com decarson@yahoo.com

