

SILVER REED

Method of Adjustment.

1. Loosen the hexagonal nut, found behind the Drop Lever, with a 7 m/m spanner. The Adjusting Lever will now be movable.

Note: Be sure to hold the Ribber with your hand as indicated in Fig. 17, or else the Ribber will drop.

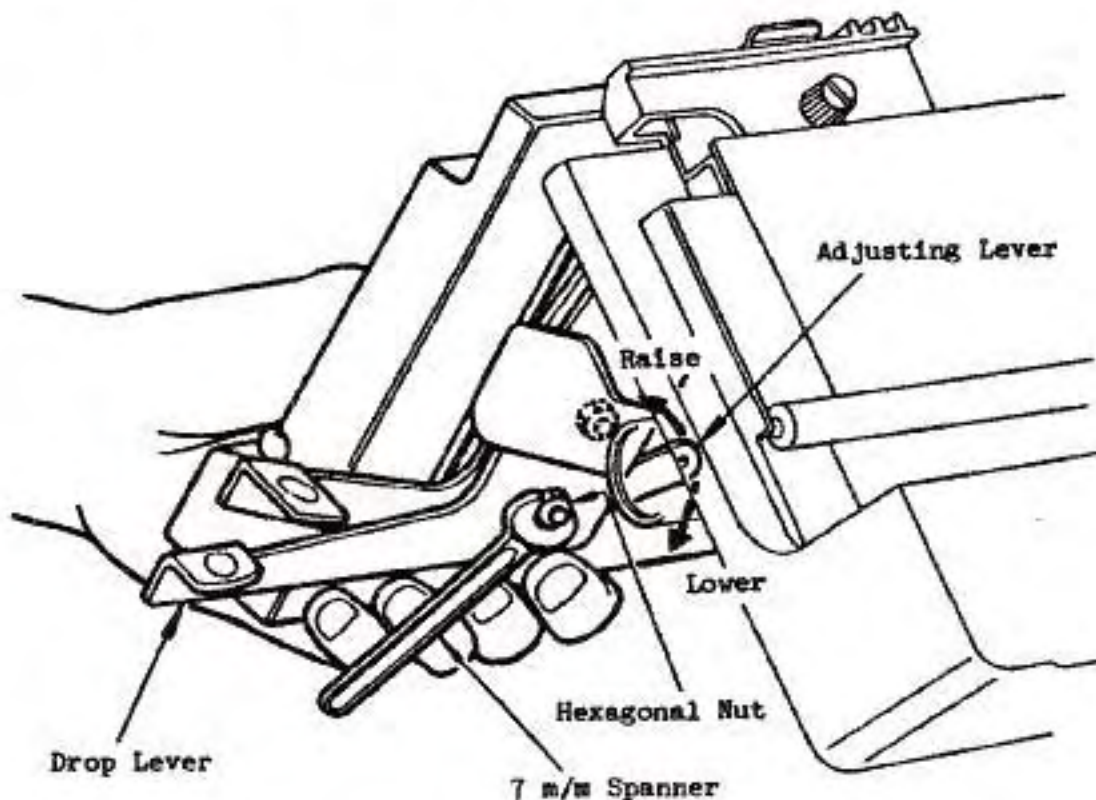

Fig. 17

2. After loosening the hexagonal nut, adjust the position by moving the Adjusting Lever in the direction of the arrow as shown in Fig. 17.

* If the vertical measurement is too wide, the Adjusting Lever must be raised.

* If the vertical measurement is too narrow, the Adjusting Lever must be lowered.

3. Fasten the hexagonal nut after the Adjustment has been completed.

1. ADJUSTMENT FOR THE NEEDLE BED.

1-1 Backward-forward positioning adjustment

* Before adjusting the position of the Needle Bed against the Knitter Needle Bed, check the backward-forward position of the Ribber Needle Bed for the correct measurement as described below.

1. Checking Method

- a) Set the Half-Pitch Lever at P.
- b) Set the Swing Indicator at 5 on the P scale using the Swing Handle.
- c) Push up five needles on both sides of the Ribber Needle Bed between 91 and 95 into D position. Measure using a feeler gauge the clearance between the Ribber Needle and the Knitter Sinker Posts as shown in Fig. 1. The measurement should be within 0.3 - 1.0mm.
- d) If the measurement is not within the range of 0.3 - 1.0mm, refer to the next page for the relevant adjustment.

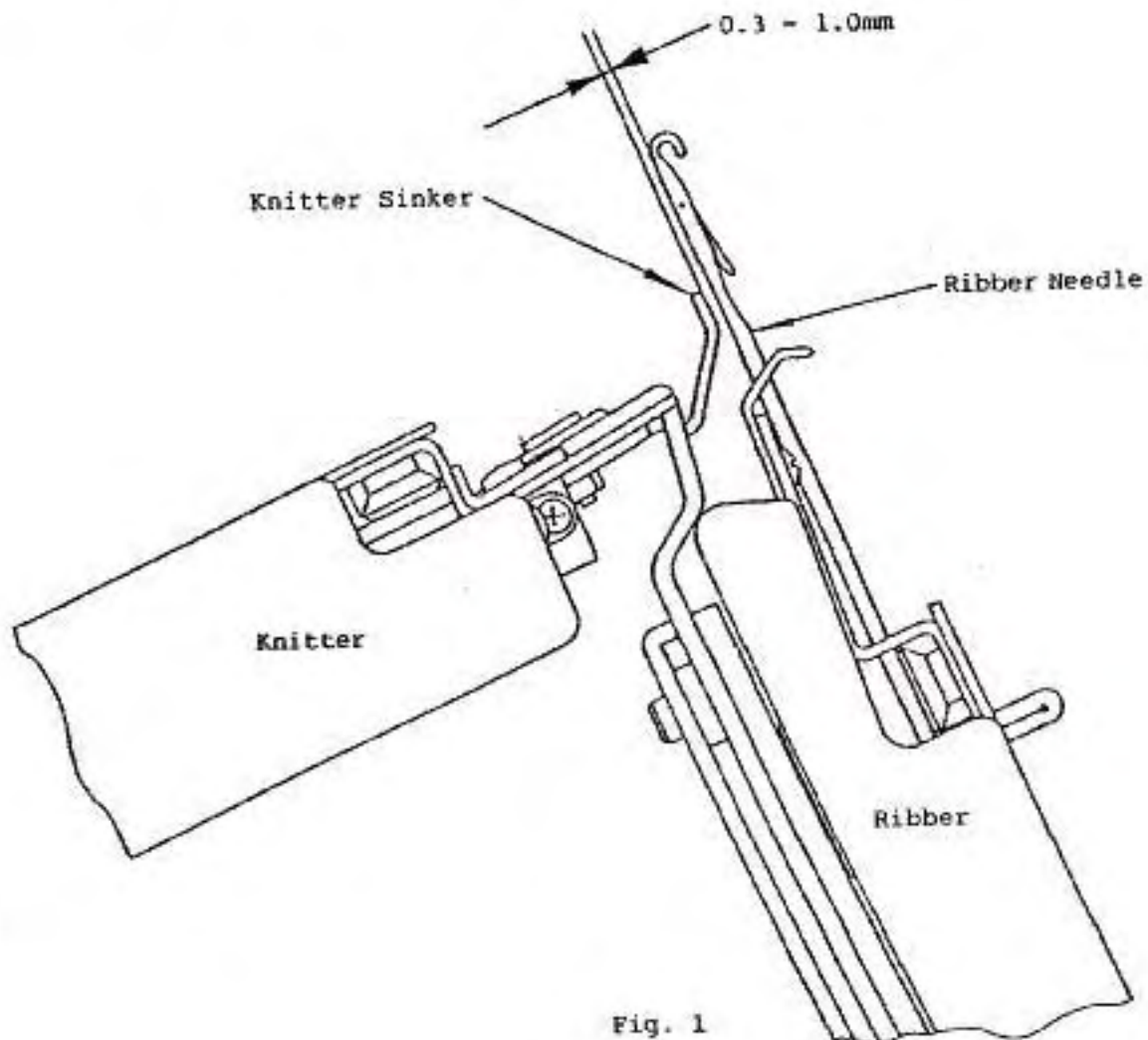

1. Method of Adjustment

In the case that the needles are not aligned, loosen two + Binding Head Screws (3x4) which secure the Half Pitch Adjusting Plate, and adjust then so as they face each other, by tapping the Ribber lightly with your hand.

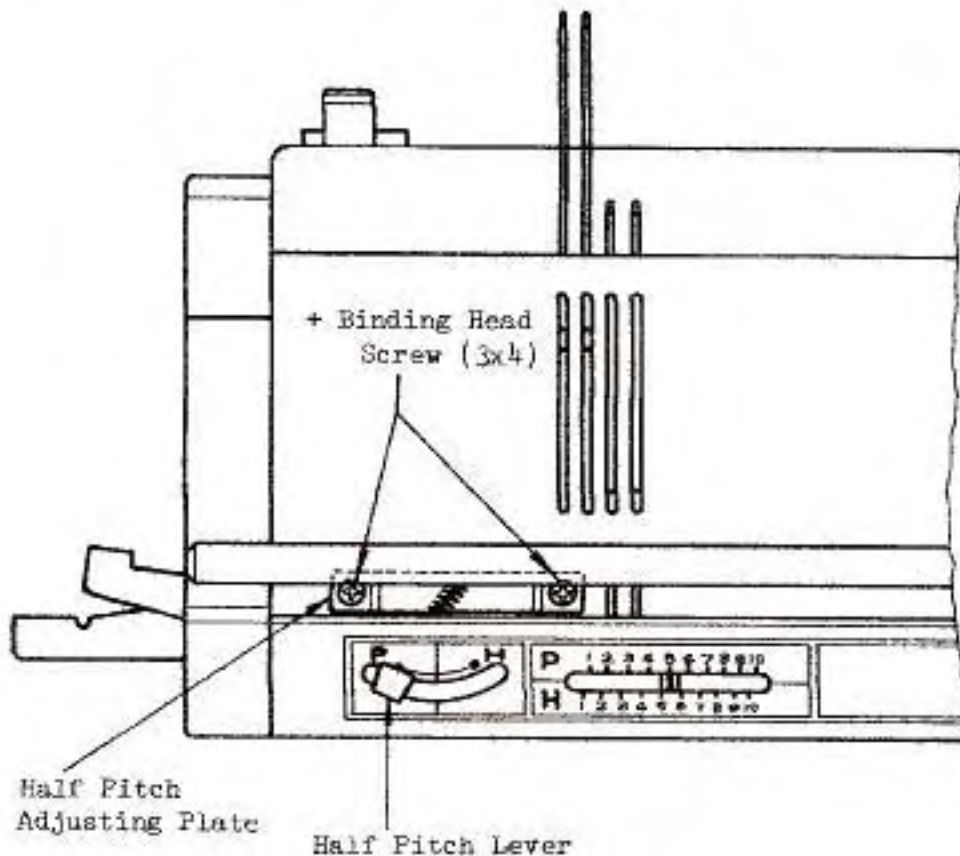

Fig. 19

Note: When this is done, adjustment of the Swing Indicator is also required.

IMPORTANT

When using SRP60N or SRP50 Ribber with MOD.700/600 Knitter, remove the Ribber Holder and Auxiliary Plate on each end of Needle Bed by unscrewing Binding Head Screws 4 × 8.

- Ⓐ Binding Head Screw 4 × 8 (2 on each side)
- Ⓑ Ribber Holder (R/L)
- Ⓒ Auxiliary Plate (R/L)

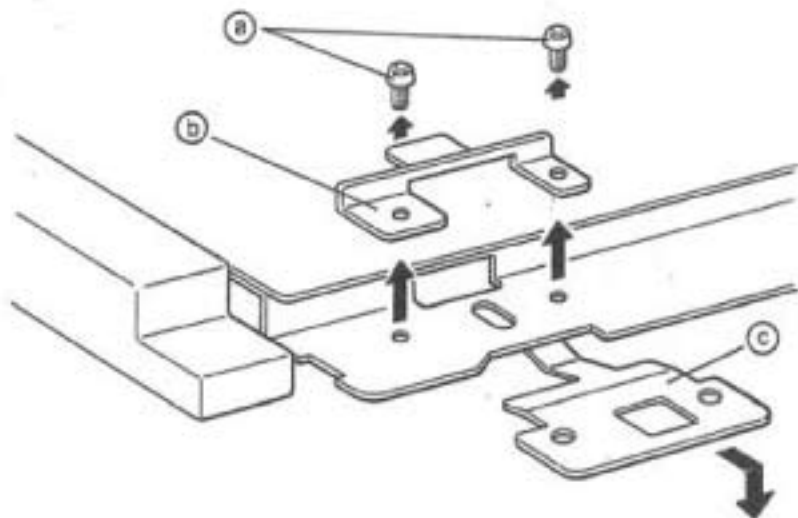

Then, attach the SRP60N or SRP50 to the Knitter according to the instructions on pages 2 to 5 of the SRP60N book, or pages 3 to 4 of the SRP50 book.

BROTHER

RIBBING ATTACHMENT KR-120/KR-710/KR-830 - KR850

1. HOW TO ADJUST THE DIMENSION IN CASE OF ATTACHING KR-120 TO KH-120, KR-710 TO KH-710 AND KR-830 TO KH-830/KH-840/KH-860/KH-881/KH-890/KH-891/KH-910/KH-930. KH 940, 950 950i, 965, 965i

* You can attach above mentioned ribbers to the knitters without any adjustment. However, if the dimension is wrong, Please follow this manual.

* There are three adjusting positions, and once you do these adjustments, you are not required to adjust when you reattach the ribber.

1.1 Meeting of needles on both beds. (See Fig.1)

The plain needles and purf needles are directly opposite to each other when the Racking indicator is on No.5 while the Half pitch lever is on P. If not, adjust the position.

- (1) Set the Half pitch lever on P.
- (2) Set the Racking indicator on No.5
- (3) Loosen two screws (-) which are beside the mark D on the left end of the KR-needle bed.
- (4) By moving the KR-needle bed from side to side, adjust to get proper position (KH and KR-needles are met directly) as shown in Fig.2
- (5) After adjusting, fasten two screws tightly.

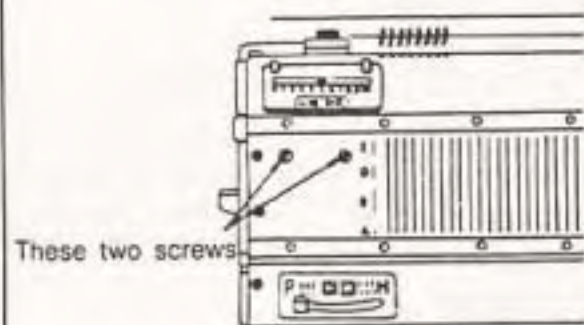
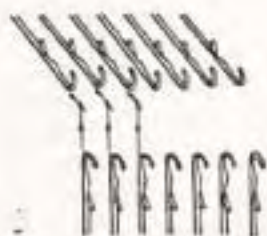

Fig.1



* Needles of each beds are met directly.

Fig.2

1.2 Height of ribber bed. (See Fig.3)

Set the half pitch lever on H, and bring forward 10 each needles on both ends of KH-needle bed. Check the clearance between the back of the KH-needles and KR-gate pegs.

* STANDARD DIMENSION

FOR KR-710 AND KR-830	1.1-1.7m/m
FOR KR-120	0-0.6m/m

- (1) By pushing down the levers on both bracket, let down the ribber one step. At the back of the ribber, you will find out the nuts. Loosen these nuts with the spanner. Then return the ribber to the original position.
- (2) By moving both height adjusters up or down, obtain the proper height. (Refer to the above mentioned standard dimension.)
- (3) After adjusting, let down the ribber one step, and fasten lightly the nuts with the spanner. (Be careful not to fasten too much.) Then lift up the ribber to normal the normal position.

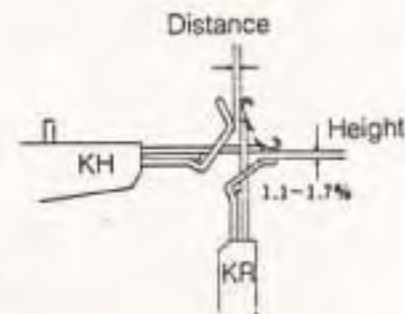
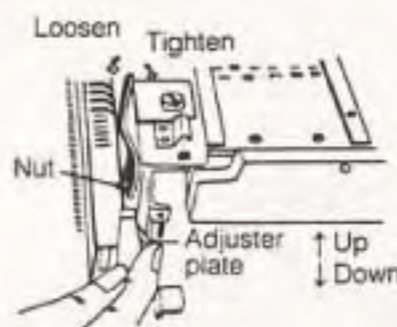

Fig.3

1.3 Distance between two beds. (See Fig.3 and Fig.4.)

Loosen the clamps for reinforcing arm. Bring forward 10 each needles on both ends of KR-needle bed. Check the distance between the back of the KR-needles and KH-gate pegs.

* STANDARD DIMENSION.

(THE COMMON DIMENSION FOR THE THREE MODELS.)

0-0.6m/m

- (1) Loosen both thumb screws with the spanner.
- (2) To obtain the proper distance (0-0.6m/m), adjust by turning the bolts on both sides of bracket with the spanner.
Turning to the left Close
Turning to the right Separate
- (3) After adjusting, go back the needles to A position and fasten both thumb screws.
- (4) Fasten the clamps for reinforcing arm.

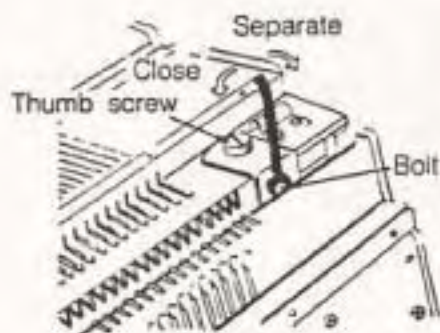

Fig.4

2. HOW TO ADJUST THE DIMENSION IN CASE OF ATTACHING KR-850 TO KH-830/KH-840/KH-860/KH-881/KH-890/KH-891/KH-910/KH-930, 940, 950, 965

* You can attach KR-850 to above mentioned knitters without any adjustment, however if the dimension is wrong, please follow this manual.

2.1 Standard dimension (See Fig.6)

- * DISTANCE No clearance is required between the back of the KR-needles and KH-gate pegs.
- * HEIGHT The clearance between the back of the KH-needles and KR-gate pegs is 0.7-1.3m/m.

2.2 For wider distance than the standard

- (1) Loosen a little the table clamps and the thumb screws of setting plates R and L.
- (2) Pull the ribber toward you.
- (3) Insert the slotted screwdriver into the slot of setting plates and pry upward to widen the slot for the adjustment like the Fig.7 and Fig.9.
- (4) After the adjustment, push the ribber to the knitter to attach correctly and fasten the thumb screws of setting plates, and table clamps.
- (5) Check the distance referring Fig.6.

2.3 For narrower distance than the standard

- (1) Loosen a little the table clamps and the thumb screws of setting plates R and L.
- (2) Adjust the clearance by means of prying upward to narrow the slots of setting plates with a slotted screwdriver while being the stay for the needle bed as the fulcrum. (See Fig.8 and Fig.9)
- (3) After the adjustment, fasten the thumb screws of setting plates and table clamps.
- (4) Check the distance referring Fig.6.



Fig.6

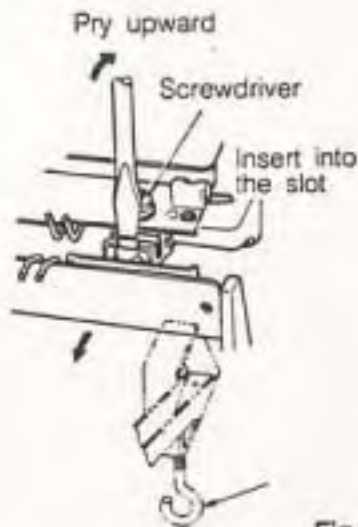

Fig.7

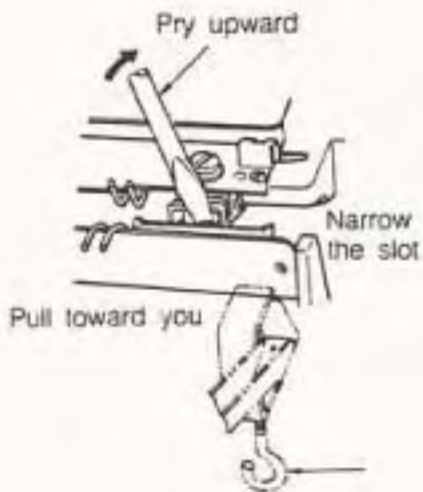

Fig.8

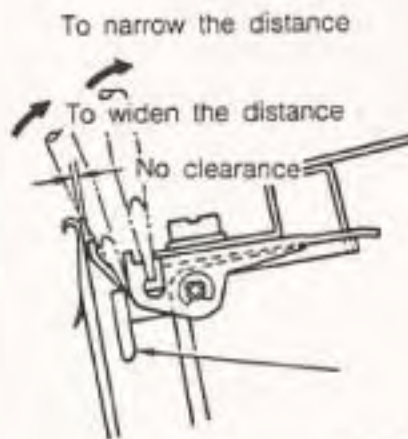

Fig.9

2.4 Height-adjustment

Please check the clearance between KR-gate pegs and the back of the needles of KH. (See Fig.11) If the dimension is wrong, adjust by the function of slide plate assembly. (Height adjuster plate.) See Page 1 for your reference. (From (1) to (3) of 1.2) (See Fig.10)

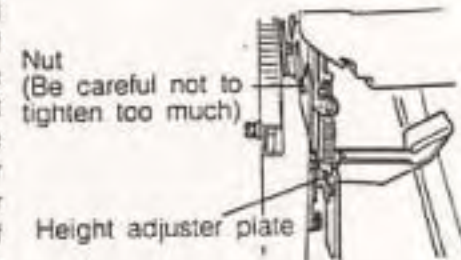

Fig.10

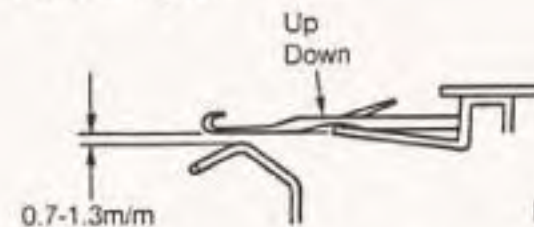

Fig.11

(Press the KH-needles downward slightly to contact Needle position indicator)