

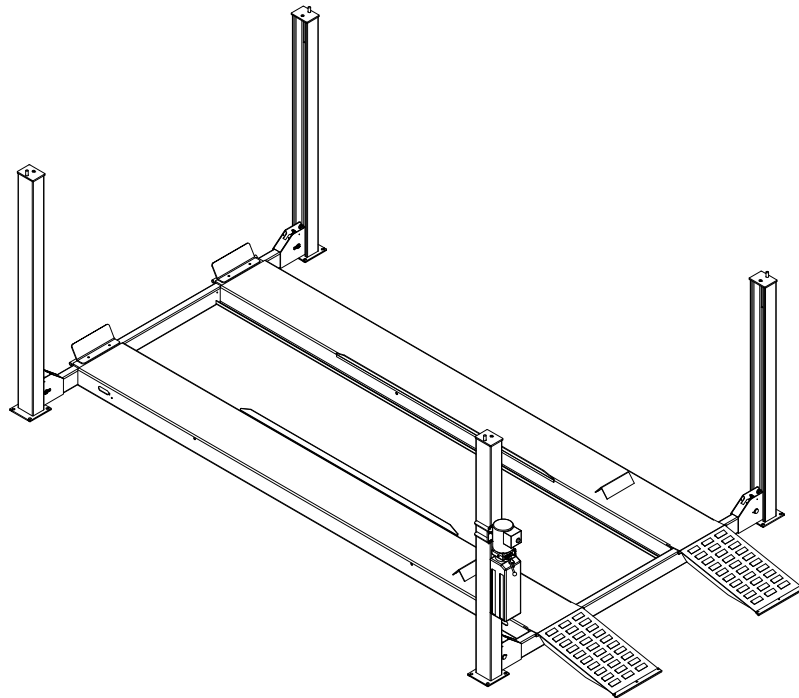

# INSTALLATION, OPERATION & MAINTENANCE MANUAL

## Four Post Surface Mounted Lift



## Model 4P12EFX and 4P12XFX

**Closed Front  
(12,000 lb Capacity)**

200 Cabel Street, P.O. Box 3944 Louisville, Kentucky 40201-3944  
Email: [sales@challengerlifts.com](mailto:sales@challengerlifts.com) Web site: [www.challengerlifts.com](http://www.challengerlifts.com)

**Office 800-648-5438 / 502-625-0700 Fax 502-587-1933**

**IMPORTANT: READ THIS MANUAL COMPLETELY BEFORE  
INSTALLING or OPERATING LIFT**

Model 4P12 Flat Deck, Closed Front  
Installation, Operation and Maintenance

GENERAL SPECIFICATIONS

MODEL: 40 [E OR X]FX

[LENGTH]

SPECIFICATIONS	4P12EFX	4P12XFX
A Length Overall	20' 4 1/2"	22' 8"
B Width Overall	10' 10 3/4"	
C Inside Columns	116"	
D Between Columns	16' 4"	18' 7 1/2"
E Height of Columns	90 1/2"	
F Height of Runways	7"	
G Width of Runways	20"	
H Width Between Runways	40" or 43"	
I Maximum Wheelbase *	182 1/2"	210"
J Rise Height	78"	
Lifting Capacity	12,000 lbs.	
Air Supply Required	85-120 psi Clean Dry	
Motor	2 HP	
Voltage (Single Phase Std.) **	208-230 Volt	
Speed of Rise	70 Seconds (approximate)	
Min. Recommended Bay Size	12' x 24'	12' x 26'

\* Wheelbase is based on a tire diameter of 30"

\*\* Optional 3 phase, 50/60Hz, 208, 230 or 460V available.

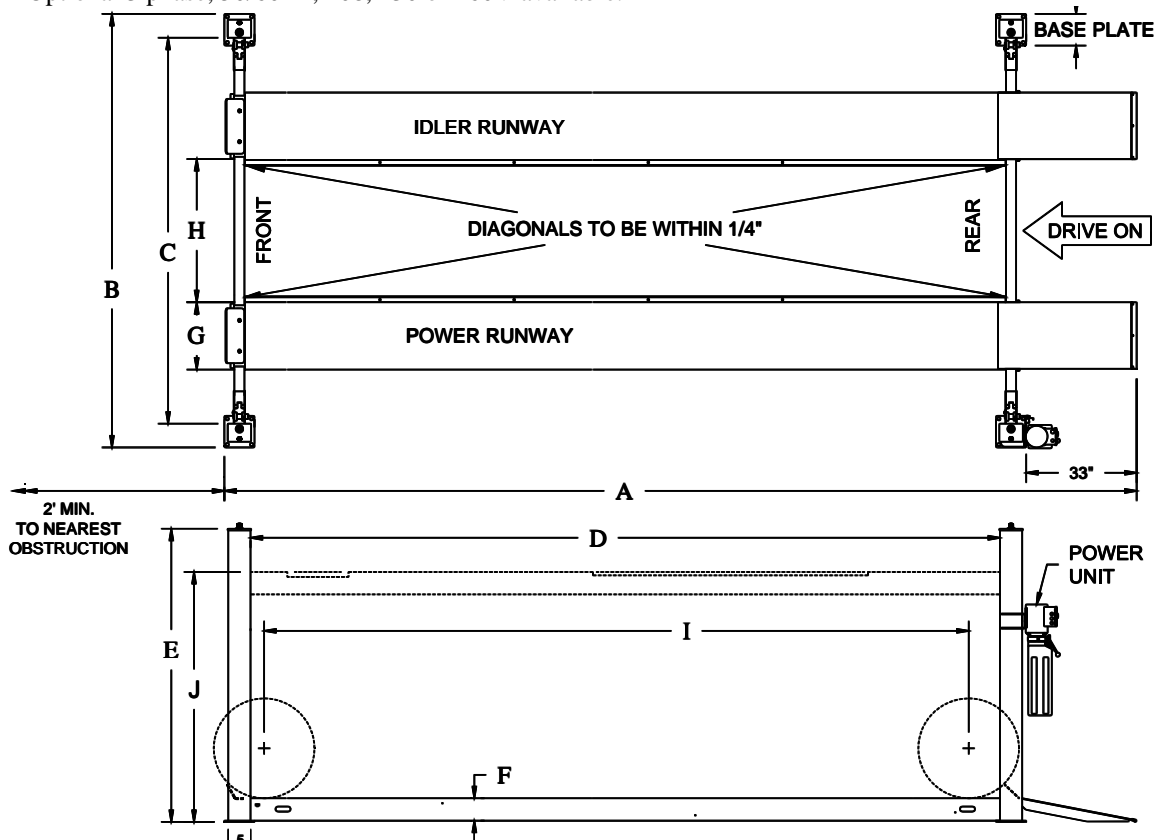

Fig 1 – General Specifications and Service Bay Layout

## VERTICAL CLEARANCE

Check the height of the area where the lift is to be installed. Clearance should be calculated based on the full raised height of the lift.



**WARNING** Failure by purchaser to provide adequate clearance could result in unsatisfactory lift performance, property damage, or personal injury.

## FLOORING

Be certain you have the proper concrete floor to properly handle the loaded lift. Floor should be in generally good condition with no large cracks, spalling or deterioration.

**Minimum requirements for concrete are 4 inches minimum depth, with steel reinforcement, 3500 psi, cured for 28 days per local commercial practice.** This lift is designed to accommodate a 3 inch total variation in elevation at the base of the four posts. Floor should be level within 1/2 inch from side-to-side and 2 1/2 front-to-rear to avoid special shimming. No anchors should be installed within 8 inches of any crack, edge, or expansion joint. If these conditions cannot be met, a pad may be poured to accommodate the lift.

Check with local building inspectors and/or permits office for any special instructions or approvals required for your installation.



**WARNING** Failure by purchaser to provide the recommended mounting surface could result in unsatisfactory lift performance, property damage, or personal injury.

## LOCATION

This lift has been evaluated for indoor use only with an operating ambient temp. range of 5 – 40°C (41-104°F)

## ELECTRICAL REQUIREMENTS

**For lift installation and operation for single-phase units, it is necessary to have a dedicated circuit with a double pole 25-amp circuit breaker or time delay fuse.**

## AIR REQUIREMENTS

This lift is equipped with an air operated lock release system. **The air supplied to the lift must be clean, dry, lubricated, and regulated to 90-120 psi, FRL (Filter/Regulator/Lubricator).** The FRL must be within 30 feet of lift. **Failure to provide clean, dry, lubricated, and pressure regulated air will void warranty on pneumatic components.**

## SAFETY NOTICES AND DECALS

For your safety, and the safety of others, read and understand all of the safety notices and decals included here.

**READ ENTIRE MANUAL BEFORE ASSEMBLING, INSTALLING, OPERATING, OR SERVICING THIS EQUIPMENT.**

**PROPER MAINTENANCE AND INSPECTION IS NECESSARY FOR SAFE OPERATION.**

**DO NOT OPERATE A DAMAGED LIFT.**

Safety decals similar to those shown here are found on a properly installed lift. Be sure that all safety decals have been correctly installed on the Power Unit reservoir. Verify that all authorized operators know the location of these decals and fully understand their meaning. Replace worn, faded, or damaged decals promptly.



**WARNING** Do not attempt to raise a vehicle on the lift until the lift has been correctly installed and adjusted as described in this manual.

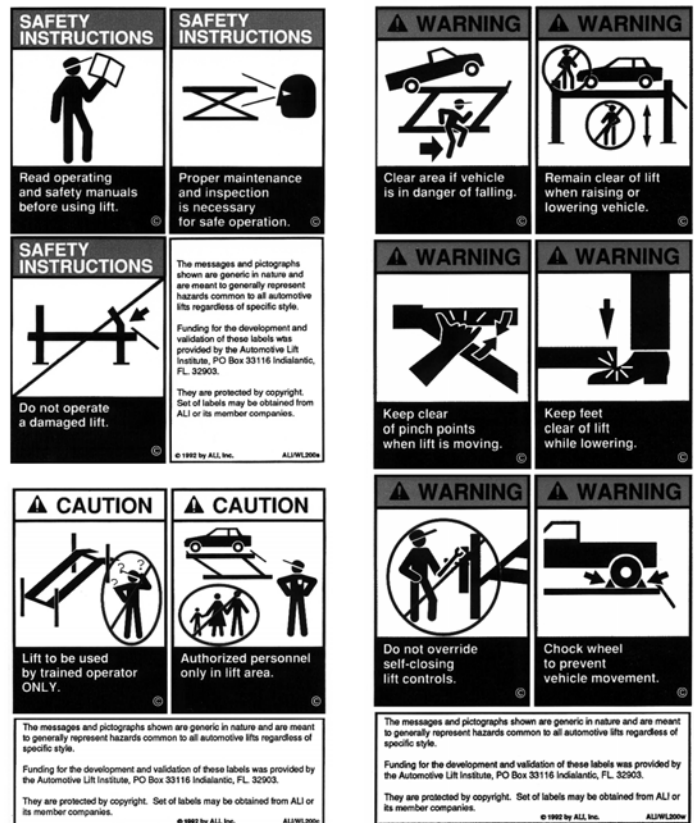

## Receiving

The shipment should be thoroughly inspected as soon as it is received. The signed bill of lading is acknowledgement by the carrier of receipt in good condition of shipment covered by our invoice.

If any of the goods called for on this bill of lading are shorted or damaged, do not accept them until the carrier makes a notation on the freight bill of the shorted or damaged goods. Do this for your own protection.

NOTIFY **Challenger Lifts** AT ONCE if any hidden loss or damage is discovered after receipt.

IT IS DIFFICULT TO COLLECT FOR LOSS OR DAMAGE AFTER YOU HAVE GIVEN THE CARRIER A CLEAR RECEIPT.

File your claim with **Challenger Lifts** promptly. Support your claim with copies of the bill of lading, freight bill, and photographs, if available.

## Component Packing List

ITEM #	QTY/ LIFT	DESCRIPTION
1	1	IDLER RUNWAY ASS'Y.
2	1	POWER RUNWAY ASS'Y
3	1	POWER COLUMN ASS'Y
4	3	IDLER COLUMN ASS'Y
5	2	ENTRANCE RAMP WELD
6	2	CROSS BEAM ASS'Y
7	1	POWER UNIT
8	1	HARDWARE BOX
9	2	MOVABLE WHEEL CHOCK
10	2	FRONT WHEEL STOP
11	2	WORK STEP (alignment lifts only)
12	2	SHIPPING BRACKET WELD
13	8	½" SHIPPING HARDWARE

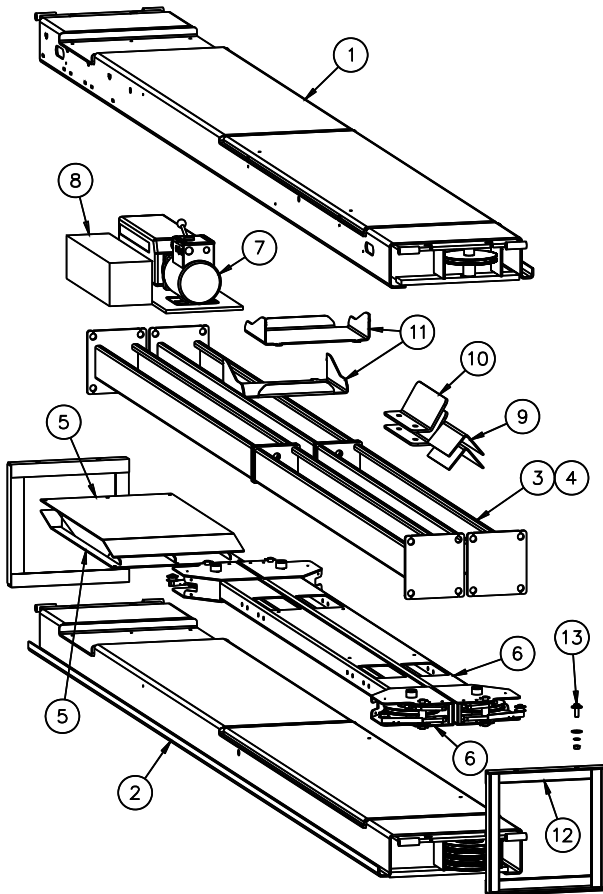

Fig 2 – Package Components

## INSTALLATION

IMPORTANT: Always wear safety glasses while installing lift.

### TOOLS (MINIMUM REQUIRED)

- a. Tape measure, 25ft
- b. Chalk line
- c. 4ft level
- d. 10" & 12" adjustable wrench
- e. Standard open end wrenches 3/8", 7/16", 1/2", 9/16", 5/8", (2) 11/16", 3/4", 15/16", 17mm
- f. 6mm allen wrench
- g. Box knife
- h. Thread locking compound
- i. Thread tape sealant (for air line)
- j. Needle nose pliers
- k. Hammer drill with 3/4" diameter carbide tipped bits
- l. 2lb hammer
- m. Torque wrench: 150 foot pounds minimum with 1 1/8" socket
- n. 8 ft. Step ladder
- o. Blocking – (4) 4x4x30", (4) 1x4x12"
- p. Transit for leveling alignment lift

### LAYOUT

- 1) Lay out the service bay according to the architect's plans or owners instructions (**see Fig 1**). Be certain that the proper conditions exist, see page 3.
- 2) Unpack lift. Remove all packaging from Power Runway (power runway has four cable sheaves at rear end) and pull threaded cable ends out. Make sure the cables are in the proper sheaves at the 4-stack, **Fig 3**.

Model 4P12 Flat Deck, Closed Front  
Installation, Operation and Maintenance

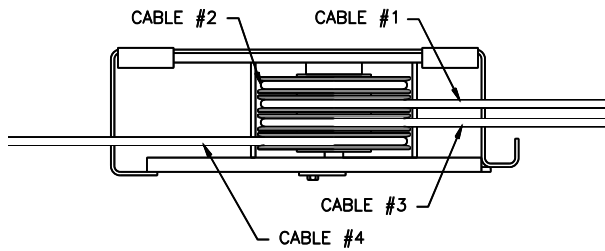

Fig 3 – Power Runway 4-Stack (rear view)

- 3) Position runways on blocking (*see Fig 4*) per layout lines established in step 1. Use four 30" long 4x4's spanning the width of the runway and four 12" long 1x4's to shim up the jack-rail

side of the runway. Cable #1, #3, & #4 should be extending out from the rear of the power runway and cable #2 from the front of the power runway, **Fig 4**.

- 4) Position the front and rear cross beams, **Fig 4**. (Both cross beams are identical.)
- 5) Reach in through either of the access holes in the cross beam tube and pull out the roll of 4mm dia. plastic air line connected to the air cylinder at the end of the cross beam. Repeat for opposite access hole and position the cross beam near the end of the runways as in **Fig 4**.

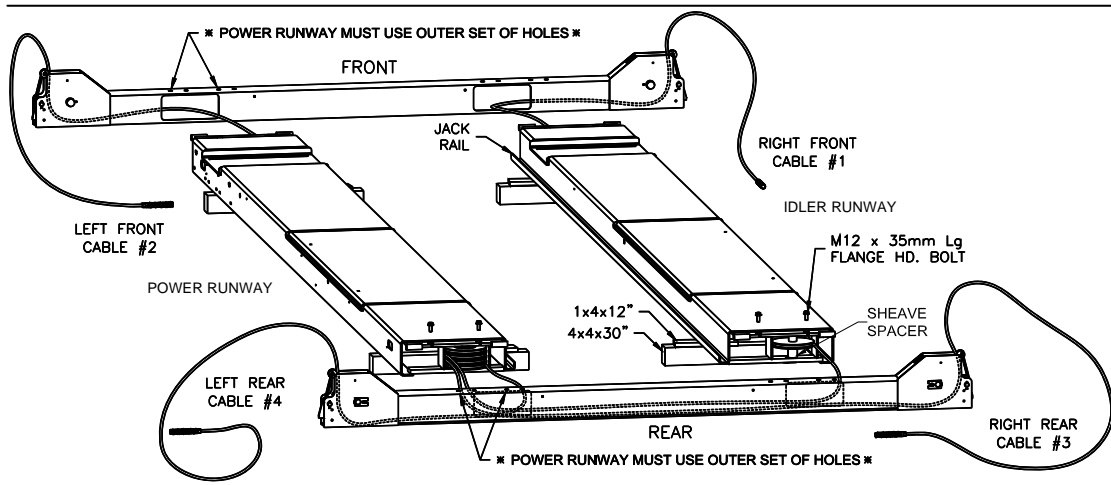

Fig 4 – Runway Layout

- 6) Remove the four (4) cross beam sheaves (one sheave from each end) and the two idler runway sheaves (also one sheave from each end). The runway sheave pins do not need to be removed, just lowered enough to remove the sheaves.
- 7) Starting from the bottom of the sheave stack, route cable #4 through the access hole and up out the left end of the rear beam. Repeat for cable #3 out the right end of the rear beam. Route cable #1 through the access hole, and back out the idler side access hole. **Look through the idler end of the cross beam and ensure that cable #1 and #3 have not crossed.**
- 8) Route cable #1 through the idler runway, into the front cross beam access hole, and out the right end of the front beam. (Don't forget to route it up over the cross-braces in the bottom of the runway.)
- 9) Route left front cable #2 through the access hole and up out the left end of the front beam.
- 10) Reinstall the cross beam sheaves with one plastic bearing washer on each side of each sheave.
- 11) Reinstall the idler runway sheaves, with one plastic bearing above and below each

sheave per **figures 5 & 6**. **Note:** use one 2 1/8" long spacer at the idler rear sheave only.

- 12) Confirm that a 2 1/8" spacer is installed at the **rear** of the idler runway and **none** at the front of power or idler runways.

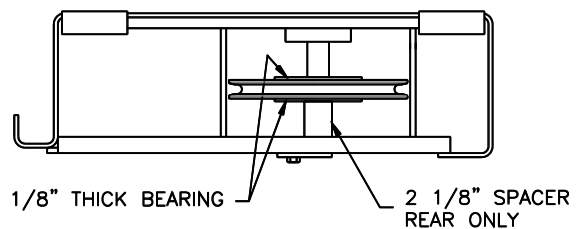

Fig 5 – Rear Single-Stack (idler runway)

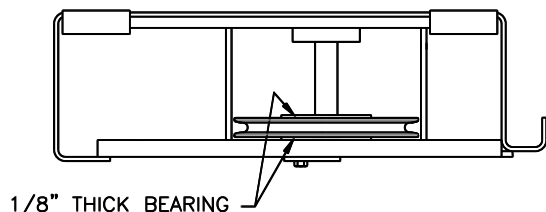
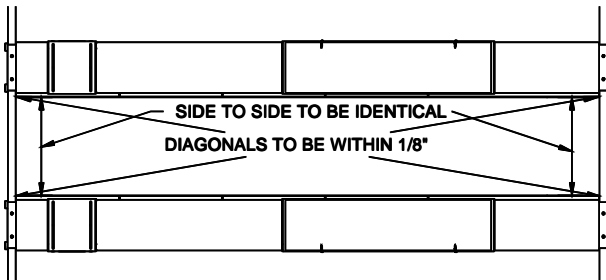

Fig 6 – Front Single-Stack (typical for idler and power runways)

- 13) Attach both cross beams to the runways (**Fig. 4**) with M12 x 35mm lg. flange head bolts (two at each end of each runway) being careful not to pinch the air line. Leave the air lines hanging out the bottom of the cross beam access holes at this time, they will be fed in through the runway after the lift is raised. **The outermost power runway slots should be in line with the outermost holes in the top of the cross beam, see Fig. 4.** The idler runway can be installed using the outer or inner sets of cross beam holes, see "Width Between Runways" dimension in Fig. 1. Do not torque bolts yet.
- 14) Check the layout of the lift in the bay. **(This is the last opportunity to reposition the lift.)** Adjust the position of the runways so the distance from power side jack rail to idler side jack rail is the same at the front and the rear and the diagonal measurements from the front tip of one rail to rear tip of the opposite rail are within 1/4", **Fig 7.**

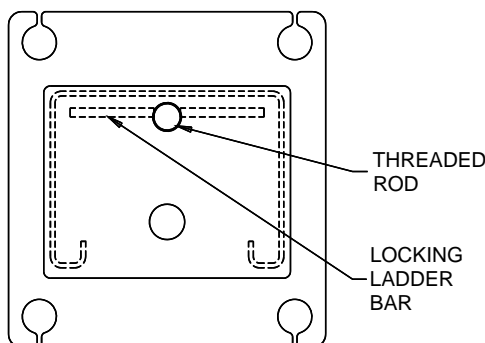

**Fig 7 – Final Runway Positioning**

- 15) Center cross beam bolts with slots in runway and tighten. (Be careful not to move runways.)

**COLUMNS**

- 16) Stand up a column assembly near each corner of the lift (column with power unit bracket goes at the 4-sheave-stack corner, power rear) and check the locking ladder bar orientation per **Fig 8**. Note that the center of the threaded rod is offset (away from the back of the column) from the center of the ladder. Thread the locking ladder jam nut (located under the column top plate) down approximately 6" to allow the ladder to be lifted freely.



**Fig 8 – Locking Ladder Orientation**

- 17) Slide power side column onto cross beam until the M8 threaded holes in the side of the beam are just exposed. Position slide blocks as shown in **Fig 9** and attach with M8 x 16mm lg. bolts (**apply thread locking compound before installing**).

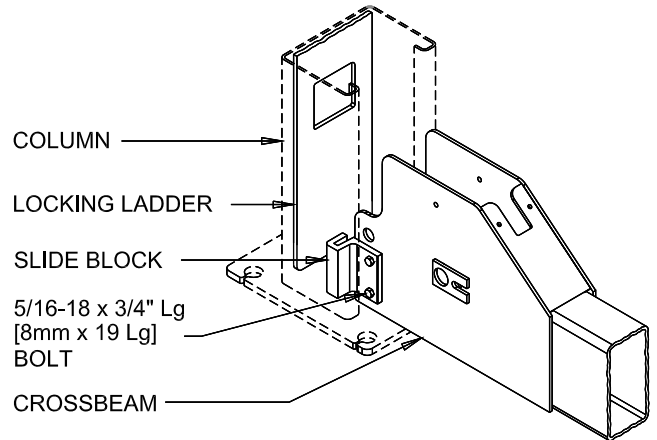

**Fig 9 – Slide Block Installation**

- 18) Raise the locking ladder, push the column against the slide blocks, and lower the ladder into the slide blocks, **Fig 10.**

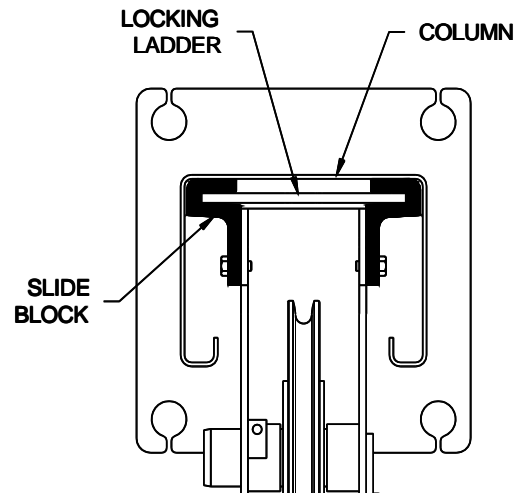

**Fig 10 – Locking Ladder Orientation**

- 19) Repeat for remaining three columns.

**ANCHORING**

- 20) The anchor bolts must be installed at least 8" from any crack, edge, or expansion joint.
- 21) Use a concrete hammer drill with a 3/4 inch carbide bit. Tip diameter should conform to ANSI Standard B94.12-1977 (.775 to .787). Do not use excessively worn bits or bits which have been incorrectly sharpened. A core bit may be necessary if an obstruction is encountered. **Never substitute with shorter anchor.**

- 22) Drill the anchor holes using the base plate as a template. Drill through the floor if possible or to a depth of 5 inches minimum.
- 23) Vacuum dust from the hole for proper holding power.
- 24) Shim columns to plumb using the shims provided or steel washers. DO NOT shim more than 1/2" at any given point. Use a level no less than 24" in length to plumb columns.
- 25) Assemble washer and nut to anchor with nut just below impact section of bolt. Drive anchor into hole until nut and washer contact base. Tighten anchor bolts and recheck column for plumb. Re-shim as required.
- 26) Torque to 150 foot-pounds to set anchors.

**NOTE: Level bubble should not only be between the lines, the bubble should be centered between the lines. If the provided shims do not allow sufficient centering of the bubble, it is best to lean the rear columns in the direction toward each other and the front columns in the direction toward each other.**

- 27) Install the four cable ends with one flat washer, one load nut, and one jam nut.
- 28) Install the power unit and the air button valve assembly on the power column, **Fig 11**.

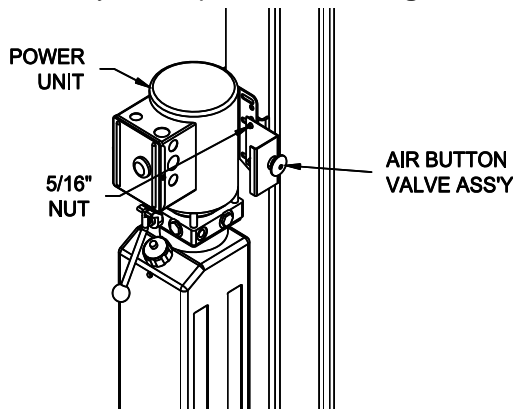

**Fig 11 – Air Button & Power Unit Mounting**

- 29) Install O-Ring end of 90 degree hydraulic elbow (9/16-18 O-Ring x 37° Male JIC) to power unit output port. The hydraulic hose is pre-installed to the hydraulic cylinder and secured inside the runway. Pull loose end out through 1 1/2" x 4 1/2" slot in the side of the power runway near the power unit and attach to the elbow fitting.

**Do Not Use Teflon Tape or Pipe Dope** on fittings.

- 30) Have a certified electrician connect the power unit to a suitable electrical power source. The standard power unit is 208/230 volt 60 Hz single phase requiring a dedicated 25 amp double poll, double throw circuit breaker to operate lift at full capacity.

- 31) **BE CERTAIN ALL FITTINGS AND CONNECTIONS ARE TIGHT. IT IS THE INSTALLERS RESPONSIBILITY TO INSURE SYSTEM IS LEAK-FREE.** Fill the Power Unit with three gallons of clean 10wt anti-foam anti-rust hydraulic oil or Dexron III ATF. **Do NOT USE OILS WITH DETERGENTS.**
- 32) Energize the power unit and raise the lift approximately 1 ft off the ground and look underneath the power runway to verify that the cable lugs are resting firmly against the cylinder pull bar.
- 33) Level the runways and crossbeams using a 4 ft. level. With the lift resting in its locks, find the highest corner and adjust the other three column ladder bars until the runways are level front-to-rear and side-to-side. Tighten jam nut against bottom side of each column top plate.
- 34) Adjust cables until all four locks are synchronized when lift is raised. Tighten cable jam nuts against adjustment nuts.
- 35) Install 4mm air line from air valve assembly thru opening in runway to Tee. **Fig 12**

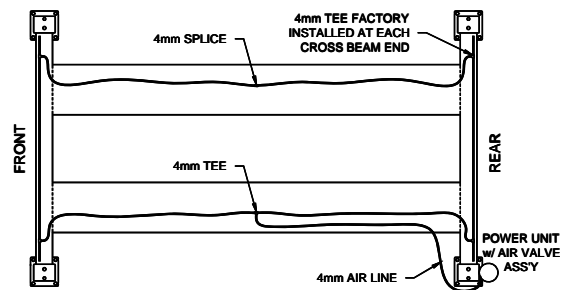

**Fig 12 – Lock Release Air Line Routing**

- 36) Route power side front and rear cross beam air lines through power runway to Tee. Route idler side front and rear cross beam air lines through idler runway and connect together with 4mm air line splice provided. Route airline through welded rings on the outside internal edge of runways.
- 37) Use the hose barb and clamp provided to connect the button valve to a suitable air source. **Air supply must be clean, dry, lubricated, and regulated to 90-120 psi.** The FRL, must be within 30 feet of valve. **Failure to provide clean, dry, lubricated, and pressure regulated air will void warranty on pneumatic components.**

- 38) Energize air valve assembly and insure that all air cylinders are working properly.
- 39) Raise and lower lift several times to bleed hydraulic cylinder. Hydraulic cylinder is self-bleeding. Lower lift and check fluid level in reservoir. Add fluid as needed.
- 40) Run lift to full rise and continue running motor approximately 5 more seconds. Check hydraulic hose and connections for leaks. Re-tighten fitting if leaking.
- 41) Raise lift approximately half way. Slowly jog power unit until you hear one of the locks engage. Adjust locking ladder until it just barely raises the crossbeam end. Back off 1/2 turn. Repeat for each column.

#### COLUMN DECAL PLACEMENT

- 42) Center the decal on the front drivers side column and rear passenger side column.
- 43) Apply decal 4" from top of columns, **Fig 13**.

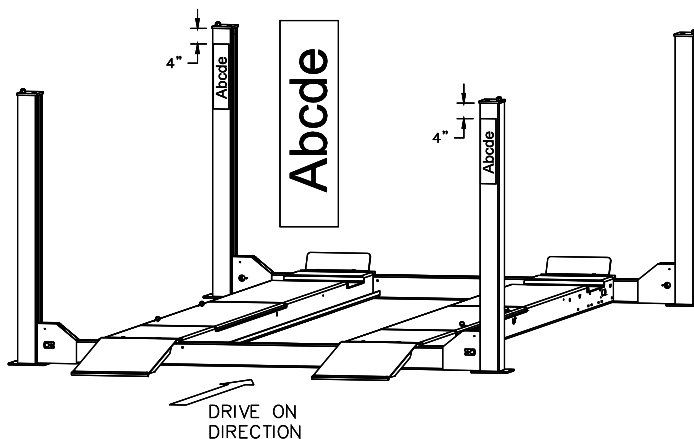

**Fig 13 – Decal Placement**



# Wiring Diagram

EACH LIFT SHOULD HAVE A DEDICATED CIRCUIT WITH A DOUBLE POLE (THREE POLE FOR 440-480V) BREAKER OR TIME DELAY FUSE SIZED ACCORDING TO THE FOLLOWING CHART

	1 $\phi$	3 $\phi$	3 $\phi$	3 $\phi$
2Hp	208-240V	208V	220-240V	440-480V
	25amp	15amp	15amp	5amp

\* WIRING MUST COMPLY WITH ALL LOCAL ELECTRICAL CODES \*

## FOR SINGLE PHASE

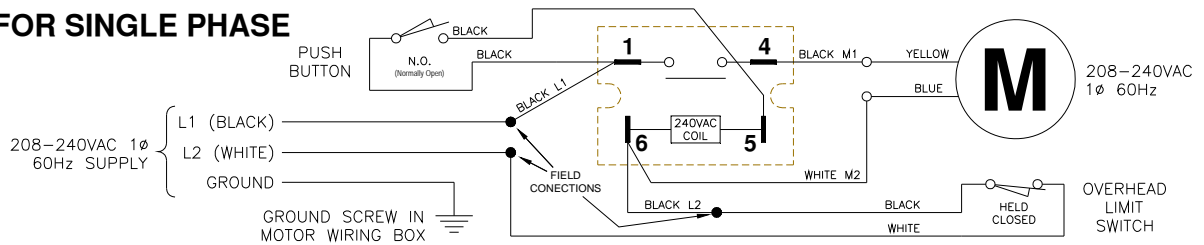

## FOR THREE PHASE

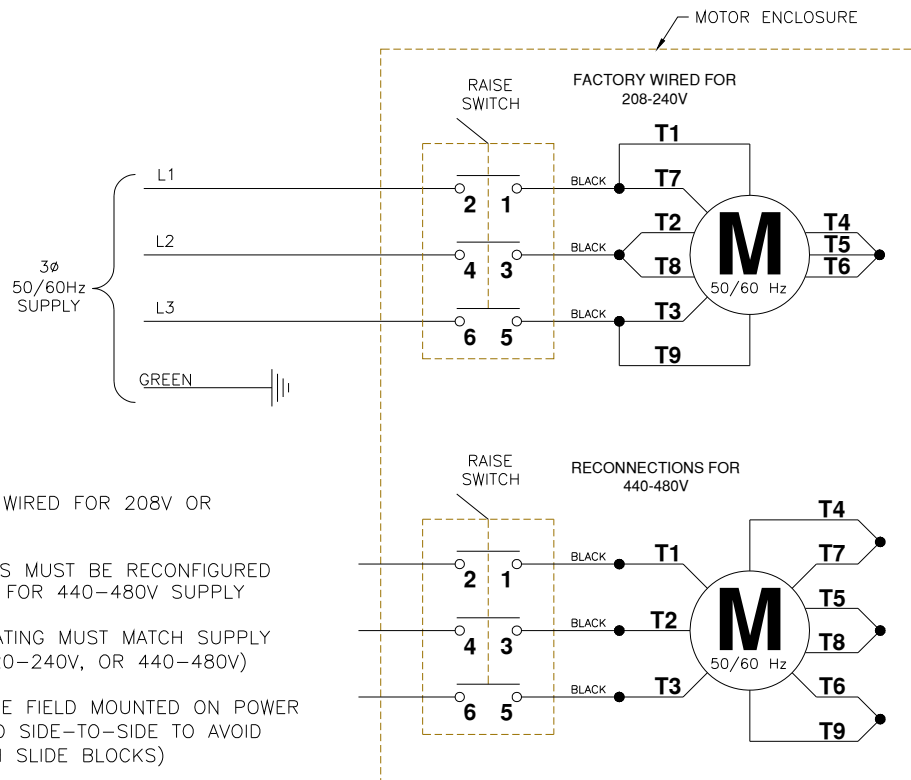

### NOTES:

- 1) MOTOR IS FACTORY WIRED FOR 208V OR 220-240V SUPPLY
- 2) MOTOR CONNECTIONS MUST BE RECONFIGURED PER THIS DIAGRAM FOR 440-480V SUPPLY
- 3) CONTACTOR COIL RATING MUST MATCH SUPPLY VOLTAGE (208V, 220-240V, OR 440-480V)
- 4) CONTACTOR MUST BE FIELD MOUNTED ON POWER COLUMN (CENTERED SIDE-TO-SIDE TO AVOID INTERFERENCE WITH SLIDE BLOCKS)
- 5) MOTOR ROTATION IS COUNTER CLOCKWISE FROM TOP OF MOTOR

Figure 14

## OWNER/OPERATOR CHECKLIST

**SAVE THESE INSTRUCTIONS** deliver them to owner/user/employee along with other materials furnished with this lift.

Demonstrate the operation of the lift to the owner/operator and review correct and safe lifting procedures using the **Lifting It Right** booklet as a guide.

Complete the Installation Checklist/Warranty Validation questionnaire with the owner. Review the terms of the warranty registration card, and return the card and a copy of the questionnaires to:

### **Challenger Lifts, Inc.**

200 Cabel Street  
Louisville, KY. 40206

## OPERATION PROCEDURE

### SAFETY NOTICES AND DECALS

**This product is furnished with graphic safety warning labels, which are reproduced on page 3 of these instructions. Do not remove or deface these warning labels, or allow them to be removed or defaced. For your safety, and the safety of others, read and understand all of the safety notices and decals included.**

### OWNER/EMPLOYER RESPONSIBILITIES

This lift has been designed and constructed according to ANSI/ALI ALCTV-2006 standard. The standard applies to lift manufactures, as well as to owners and employers. The owner/employer's responsibilities as prescribed by ANSI/ALI ALOIM-2000, are summarized below. For exact wording refer to the actual standard provided with this manual in the literature pack.

**The Owner/Employer shall** insure that lift operators are qualified and that they are trained in the safe use and operation of the lift using the manufacturer's operating instructions; ALI/SM 93 -1, ALI Lifting it Right safety manual; ALI/ST-90 ALI Safety Tips card; ANSI/ALI ALOIM-2000, American National Standard for Automotive Lifts-Safety Requirements for Operation, Inspection and Maintenance; ALI/WL Series, ALI Uniform Warning Label Decals/Placards; and in case of frame engaging lifts, ALI/LP-GUIDE, Vehicle Lifting Points/Quick Reference Guide for Frame Engaging Lifts.

**The Owner/Employer shall** establish procedures to periodically inspect the lift in accordance with the lift manufacturer's instructions or ANSI/ALI ALOIM-2000, American

National Standard for Automotive Lifts-Safety Requirements for Operation, Inspection and Maintenance; and the employer shall insure that the lift inspectors are qualified and that they are adequately trained in the inspection of the lift.

**The Owner/Employer shall** establish procedures to periodically maintain the lift in accordance with the lift manufacturer's instructions or ANSI/ALOIM-2000, American National Standard for Automotive Lifts-Safety Requirements for Operation, Inspection and Maintenance; and the employer shall insure that the lift maintenance personnel are qualified and that they are adequately trained in the maintenance of the lift.

**The Owner/Employer shall** maintain the periodic inspection and maintenance records recommended by the manufacturer or ANSI/ALI ALOIM-2000, American National Standard for Automotive Lifts-Safety Requirements for Operation, Inspection and Maintenance.

**The Owner/Employer shall** display the lift manufacturer's operating instructions; ALI/SM 93 -1, ALI Lifting it Right safety manual; ALI/ST-90 ALI Safety Tips card; ANSI/ALI ALOIM-2000, American National Standard for Automotive Lifts-Safety Requirements for Operation, Inspection and Maintenance; and in the case of frame engaging lift, ALI/LP-GUIDE, Vehicle Lifting Points/Quick Reference Guide for Frame Engaging Lifts; in a conspicuous location in the lift area convenient to the operator.

## IMPORTANT SAFETY INSTRUCTIONS

When using your garage equipment, basic safety precautions should always be followed, including the following:

1. Read all instructions.
2. Care must be taken as burns can occur from touching hot parts.
3. To reduce the risk of fire, do not operate equipment in the vicinity of open containers of flammable liquids (gasoline).
4. Keep hair, loose clothing, fingers, and all parts of body away from moving parts.
5. Use only as described in this manual. Use only manufacturer's recommended attachments.
6. ALWAYS WEAR SAFETY GLASSES. Everyday eyeglasses only have impact resistant lenses, they are not safety glasses.

SAVE THESE INSTRUCTIONS

### Important Safety Instructions

When using your garage equipment, basic safety precautions should always be followed, including the following:

- 1 Read all instructions.
- 2 Care must be taken as burns can occur from touching hot parts.
- 3 To reduce the risk of fire, do not operate equipment in the vicinity of open containers of flammable liquids (gasoline).
- 4 Adequate ventilation should be provided when working on operating internal combustion engines.
- 5 Keep hair, loose clothing, fingers, and all parts of body away from moving parts.
- 6 To reduce the risk of electric shock, do not use on wet surfaces or expose to rain.
- 7 Use only as described in this manual. Use only manufacturer's recommended attachments.

### Save These Instructions

#### LIFTING A VEHICLE

Drive vehicle onto lift. Set parking brake and/or use wheel chocks that are provided with lift.

When the vehicle has reached the desired working height, release the power pack button, and lower the vehicle until the safety locks are engaged. The vehicle should remain level when all locks are engaged. If one side engages and the other continues to descend, stop lowering the vehicle, raise it several inches, and try again to engage locks.

**IMPORTANT**, Before walking under the lift insure that all locks are properly engaged.

It is not safe to work under the vehicle unless all locks are engaged, and the vehicle is level.

#### LOWERING A VEHICLE

Insure that the area under the vehicle is clear of personnel and tools.

Raise the vehicle until locks are free.

Disengage the locks by depressing the palm button and holding it.

Lower the vehicle by depressing the lowering valve handle. Watch lift to insure that the lift is lowering evenly. If not, raise lift and check all locks to insure they are disengaged before trying to lower lift again.

Continue to lower the vehicle until the crossbeams stop against the base plate. It is important to fully lower the lift to release hydraulic pressure on the system.

#### MAINTENANCE

To avoid personal injury, permit only qualified personnel to perform maintenance on this equipment. Maintenance personnel should follow lockout/tagout instructions per ANSI Z244.1.

The following maintenance points are suggested as the basis of a routine maintenance program.

The actual maintenance program should be tailored to the installation. See ANSI/ALI ALOIM booklet for periodic inspection checklist and maintenance log sheet.

- If lift stops short of full rise or chatters, check fluid level and bleed both cylinders per Installation Instructions.
- Replace all Safety, Warning or Caution Labels if missing or damaged. (**See *Installation instructions page 3.***)

#### Daily

- Keep lift components clean. **To keep alignment lifts with rear slip plates working properly use compressed air to blow out any debris from the bearing area.**
- Check for loose or broken parts.
- Check hydraulic system for fluid leaks.
- Check lock release activation.

#### Weekly

- Check cables and sheaves for wear or damage. Replace as required with genuine Challenger Lifts parts.
- Inspect lock mechanism for proper function.

#### Monthly

- Torque concrete anchor bolts to 80 ft-lbs.
- Clean and inspect cables and sheaves for wear or damage. Lubricate cables and sheaves with light oil.
- Visually inspect concrete floor for cracks and/or spalls within 12" of base plate

**IMPORTANT ! Failure to keep lift free of corrosive agents and solvents will lead to reduced service life, which could result in property damage and/or personal injury.**

**If any problems are encountered, contact your local service representative.**

# Parts Breakdown

Model 4P12EFX/4P12XFX

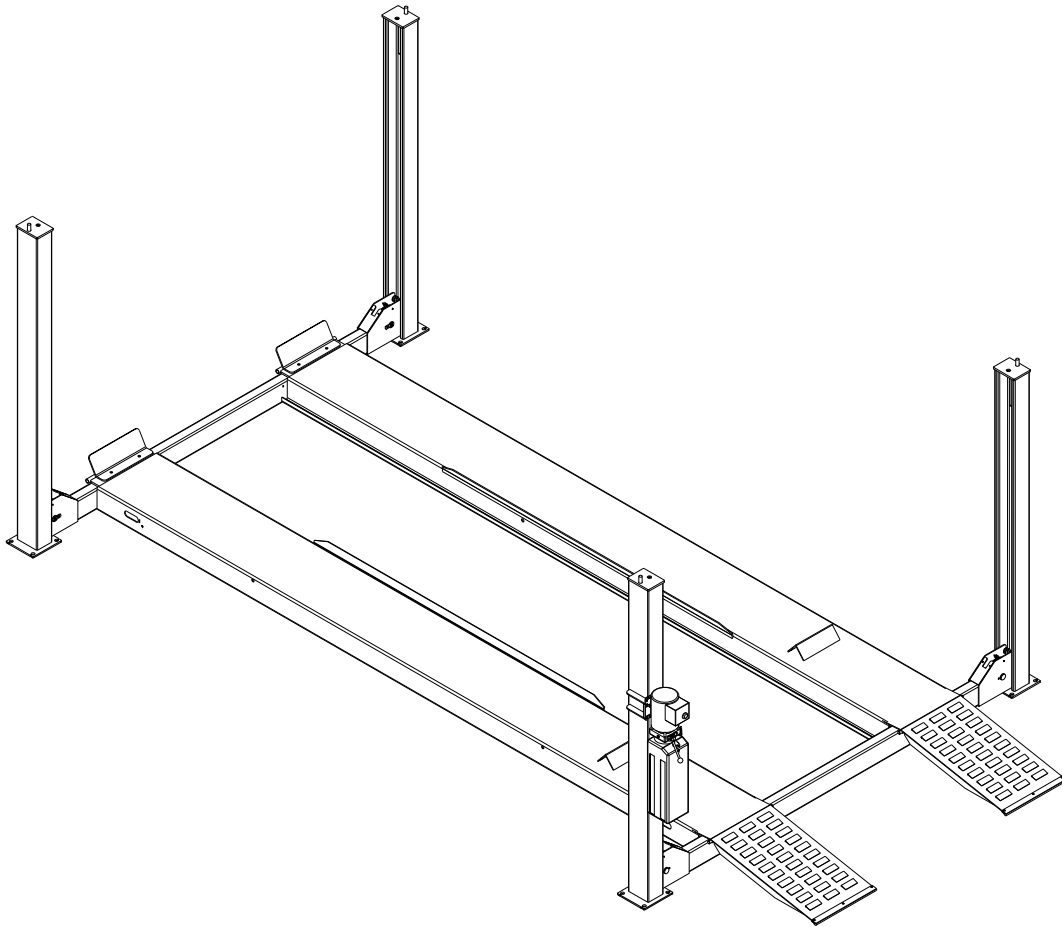

IMPORTANT!!!

**Replace all worn or broken parts with genuine *Challenger Lifts Inc.* parts. Contact your local *Challenger Lifts* parts distributor for pricing and availability. Call 502-625-0700 for the closest parts distributor in your area.**

# Parts Breakdown

Fig A. General Layout

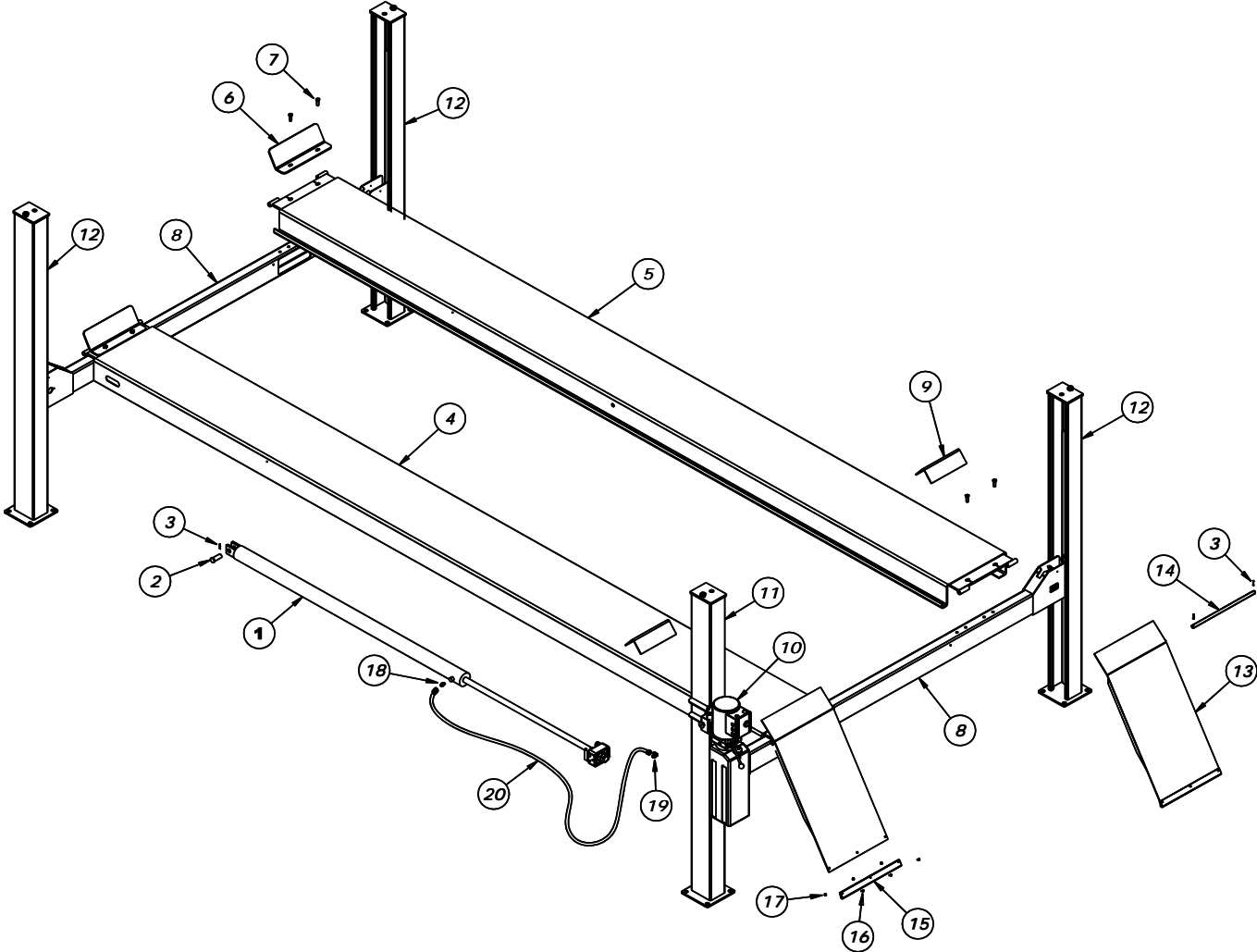

Model 4P12 Flat Deck, Closed Front  
Installation, Operation and Maintenance

ITEM #	PART #	QTY/LIFT	DESCRIPTION
1	B44011	1	HYDRAULIC CYLINDER
2	B40082	1	CLEVIS PIN
3	B40126	5	1/8 x 1 1/2" Lg. COTTER PIN
4	B40391	1	FLAT DECK POWER RUNWAY (4P12XF)
	B40381		FLAT DECK POWER RUNWAY (4P12EF)
5	B40393	1	FLAT DECK IDLER RUNWAY (4P12XF)
	B40383		FLAT DECK IDLER RUNWAY (4P12EF)
6	B40266	2	WHEEL STOP
7	B40083	8	M12 x 35mm Lg. HEX.FLG.HD.CAP SCREW
8	B40460	1	CROSS BEAM ASSEMBLY
9	B40265	2	WHEEL CHOCK
10	31368-19	1	POWER UNIT 1 PHASE, 60Hz, 208-230VAC
	31355-19		POWER UNIT 3 PHASE, 230/460VAC
11	B40449-P	1	POWER COLUMN ASSEMBLY
12	B40449-I	3	IDLER COLUMN ASSEMBLY
13	B40161	2	ENTRANCE RAMP
14	B40165	2	RAMP HINGE PIN
15	40168	2	RAMP SLIDE
16	31062	6	1/4-20NC x 3/4" Lg. PAN HEAD SCREW
17	40085	6	1/4-20NC HEX FLANGE NUT
18	BA1121	1	UNION ADAPTER #6 O-RING x #6 JIC 37 deg FLARE
19	B16167	1	90 DEGREE ADAPTER ELBOW – MALE #6 O-RING x MALE #6 J.I.C.
20	B40349	1	HYDRAULIC HOSE – FEMALE #6 J.I.C. BOTH ENDS

Replace all worn or broken parts with genuine **Challenger Lifts Inc.** parts.  
Contact your local Challenger Lifts Parts Distributor for pricing and availability.  
**(Call Challenger Lifts Inc. (502) 625-0700 for the Parts Distributor in your area)**

Model 4P12 Flat Deck, Closed Front  
Installation, Operation and Maintenance

PARTS BREAKDOWN (continued)

*Fig B. Cables*

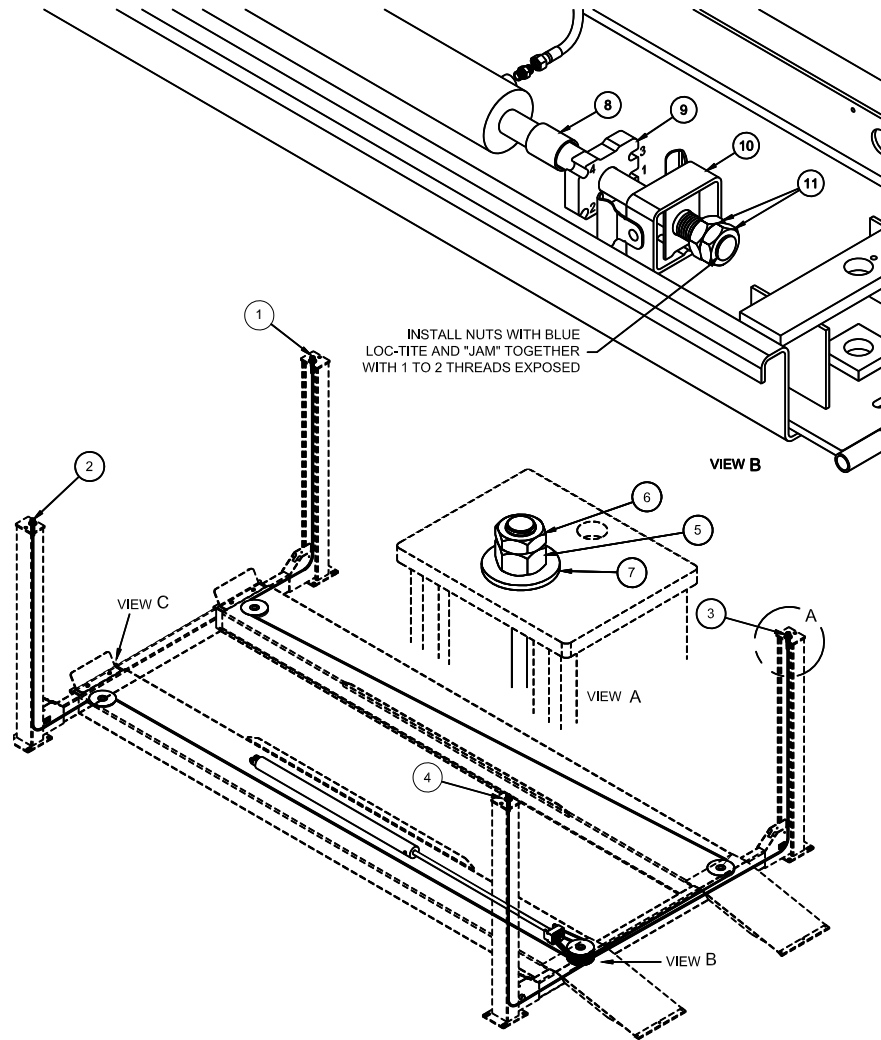

ITEM #	PART #	QTY/LIFT	DESCRIPTION
1	40372-X1	1	RIGHT FRONT CABLE #1 (4P12X)
	40372-E1		RIGHT FRONT CABLE #1 (4P12E)
2	40372-X2	1	LEFT FRONT CABLE #2 (4P12X)
	40372-E2		LEFT FRONT CABLE #2 (4P12E)
3	40472-3	1	RIGHT REAR CABLE #3
4	40472-4	1	LEFT REAR CABLE #4
5	40147	4	7/8-9 HEX NUT
6	40148	4	7/8-9 HEX JAM NUT
7	40149	4	7/8 FLAT WASHER
8	B40438-R	1	2 1/8" SPACER
9	B40473	1	CABLE PULL BAR
10	B40474	1	CABLE RETAINER WELD
11	B44015	2	M27 JAM NUT

Replace all worn or broken parts with genuine **Challenger Lifts Inc.** parts.  
Contact your local Challenger Lifts Parts Distributor for pricing and availability.  
**(Call Challenger Lifts Inc. (502) 625-0700 for the Parts Distributor in your area)**

Model 4P12 Flat Deck, Closed Front  
Installation, Operation and Maintenance

PARTS BREAKDOWN (continued)

Fig C. Runway Sheaves

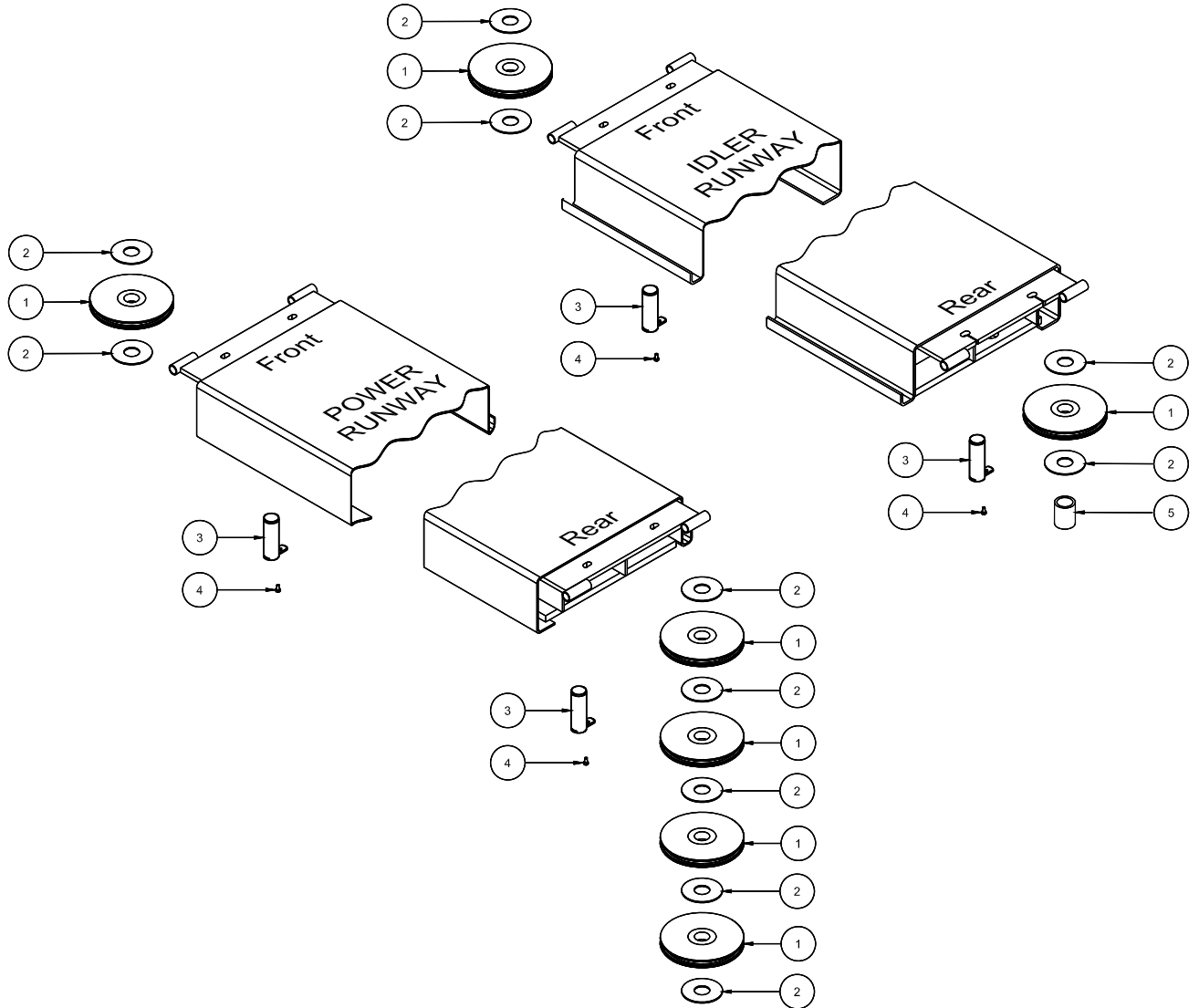

ITEM #	PART #	QTY/LIFT	DESCRIPTION
1	B40050	10	SHEAVE
2	B40053	11	1/8" THICK BEARING
3	B40055	4	SHEAVE PIN ASSEMBLY (RUNWAY)
4	B31188	16	M8 x 16mm Lg HEX LOCKING FLANGE HEAD CAP SCREW
5	B40438-R	1	RUNWAY SHEAVE SPACER

Replace all worn or broken parts with genuine **Challenger Lifts Inc.** parts.  
Contact your local Challenger Lifts Parts Distributor for pricing and availability.  
**(Call Challenger Lifts Inc. (502) 625-0700 for the Parts Distributor in your area)**



Model 4P12 Flat Deck, Closed Front  
Installation, Operation and Maintenance

PARTS BREAKDOWN (continued)

*Fig D. Cross Beam*

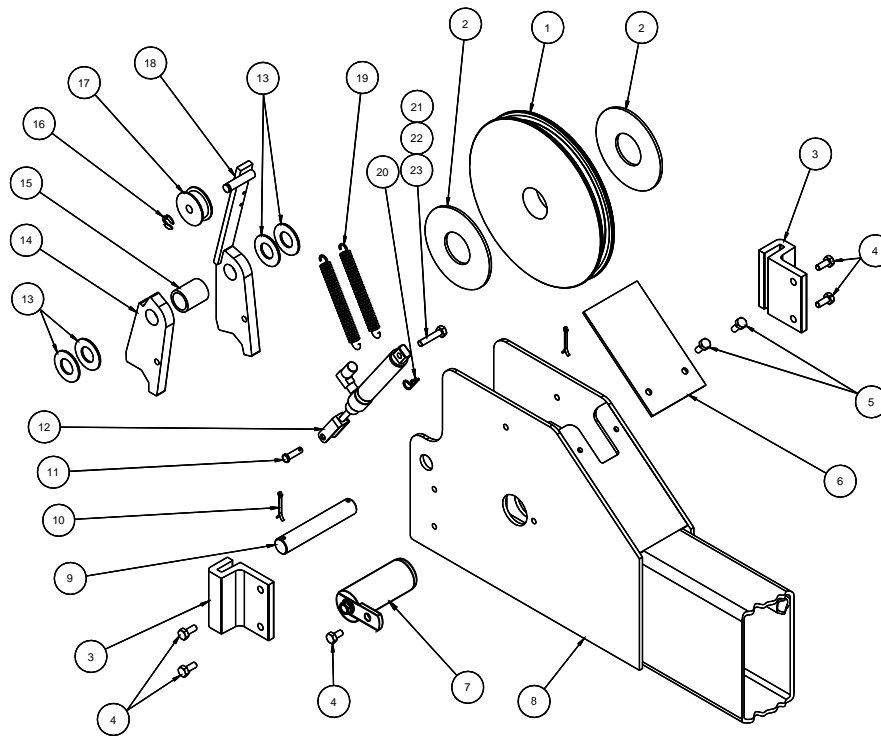

ITEM #	PART #	QTY/LIFT	DESCRIPTION
1	B40050	10	SHEAVE
2	B40053	4	1/8" THICK BEARING
3	B40118	8	SLIDE BLOCK
4	B31188	16	M8 x 16mm Lg. HEX SOCKET HEAD CAP SCREW
5	40120	8	1/4-20NC x 1/2" Lg. SELF TAPPING SCREW
6	40122	2	RUBBER SHEAVE GUARD (REAR)
7	B40116	4	SHEAVE PIN ASSEMBLY (CROSS BEAM)
8	B40461	1	REAR CROSS BEAM WELD
9	B40127	4	LOCK PIVOT PIN
10	B40126	8	3mm x 38mm Lg. COTTER PIN
11	B40123	4	CLEVIS PIN
12	B40141	4	AIR CYLINDER ASSEMBLY
13	B40128	16-28	19mm WASHER – (1.5 O.D. x .13 THICK NOMINAL)
14	B40131	4	PRIMARY LOCK PAWL
15	B40132	4	SPACER BUSHING
16	B40137	2	RETAINING RING
17	B40135	2	ROLLER
18	B40134	2	SLACK CABLE LATCH
19	B40139	8	EXTENSION SPRING
20	B40124	4	HAIR PIN COTTER PIN
21	B40466	2	M6 x 28mm Lg HEX HEAD BOLT
22	B40467	2	M6 HEX NUT
23	B40144	2	M6 HEX JAM NUT

Replace all worn or broken parts with genuine **Challenger Lifts Inc.** parts.  
Contact your local Challenger Lifts Parts Distributor for pricing and availability.  
**(Call Challenger Lifts Inc. (502) 625-0700 for the Parts Distributor in your area)**

Model 4P12 Flat Deck, Closed Front  
Installation, Operation and Maintenance

PARTS BREAKDOWN (continued)

*Fig F. Air Lock Release*

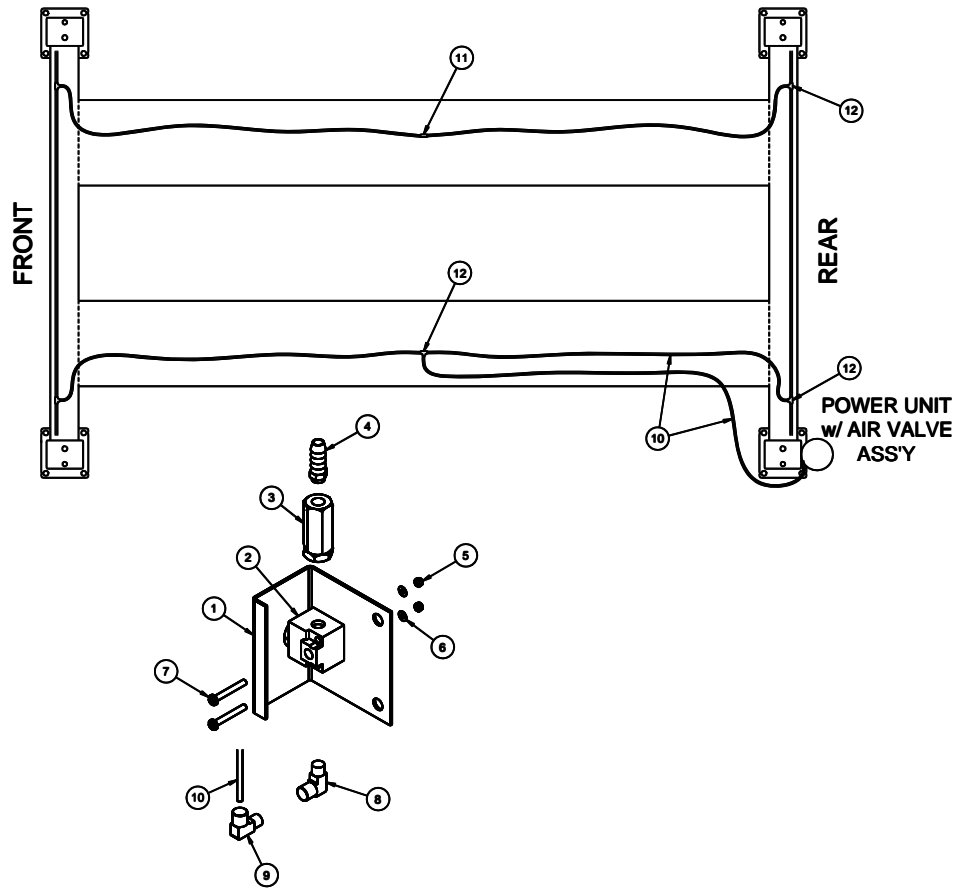

ITEM #	PART #	QTY/LIFT	DESCRIPTION
1	37015	1	BUTTON VALVE BRACKET
2	37016	1	AIR VALVE
3	40091	1	IN-LINE AIR FILTER
4	37021	1	HOSE BARB
5	37023	2	#8-32 HEX NUT
6	37024	2	#8 LOCK WASHER
7	37022	2	#8-32 x 1 1/4" Lg. PAN HD. SCREW
8	37020	1	1/8" NPT STREET ELBOW
9	B37019	1	1/8" NPTM x 4mm PUSH-LOCK 90 DEGREE ELBOW
10	B00901	60 ft.	4mm DIA. PLASTIC AIR LINE
11	B40445	1	4mm STRAIGHT UNION
12	B37032	5	4mm UNION TEE

Replace all worn or broken parts with genuine **Challenger Lifts Inc.** parts.  
Contact your local Challenger Lifts Parts Distributor for pricing and availability.  
**(Call Challenger Lifts Inc. (502) 625-0700 for the Parts Distributor in your area)**