



---

*Installation, Operation & Maintenance Manual*

# *MODEL QRJ03H*

## *ROLLING JACK*

*(Q4P07 Series 4-Post only)*

*3,500 lbs Capacity*



200 Cabel Street, P.O. Box 3972, Louisville, Kentucky 40206

Email: [sales@qualitylifts.com](mailto:sales@qualitylifts.com) Web site: [www.qualitylifts.com](http://www.qualitylifts.com)

Office 877-771-5438/ 502-583-5438 Fax 502-583-5488

**IMPORTANT: READ THIS MANUAL COMPLETELY  
BEFORE INSTALLING or OPERATING JACK**

## CAUTION

- ◆ Before using this product, read and fully understand the operating instructions and all decals on the product. This is necessary to prevent injury to the operator and damage to the product.
- ◆ Roll jack forward before moving vehicle on or off lift.
- ◆ Do not attempt to use this jack for anything other than its intended purpose.
- ◆ If jack begins to tilt as the vehicle is raised, STOP! Lower jack and reposition the vehicle.
- ◆ Do not use this jack if it is visibly worn, distorted or damaged.
- ◆ Always wear appropriate eye protection.

## WARNING

- ◆ Maximum lift capacity of this jack is 3500 lbs.  
Exceeding this could result in severe personal injury or death.
- ◆ Lift vehicle at manufacturer's recommended pick-up points only.  
Vehicle weight must be evenly distributed on each jack lift pad.
- ◆ Keep fingers and hands clear of all pinch points at all times.

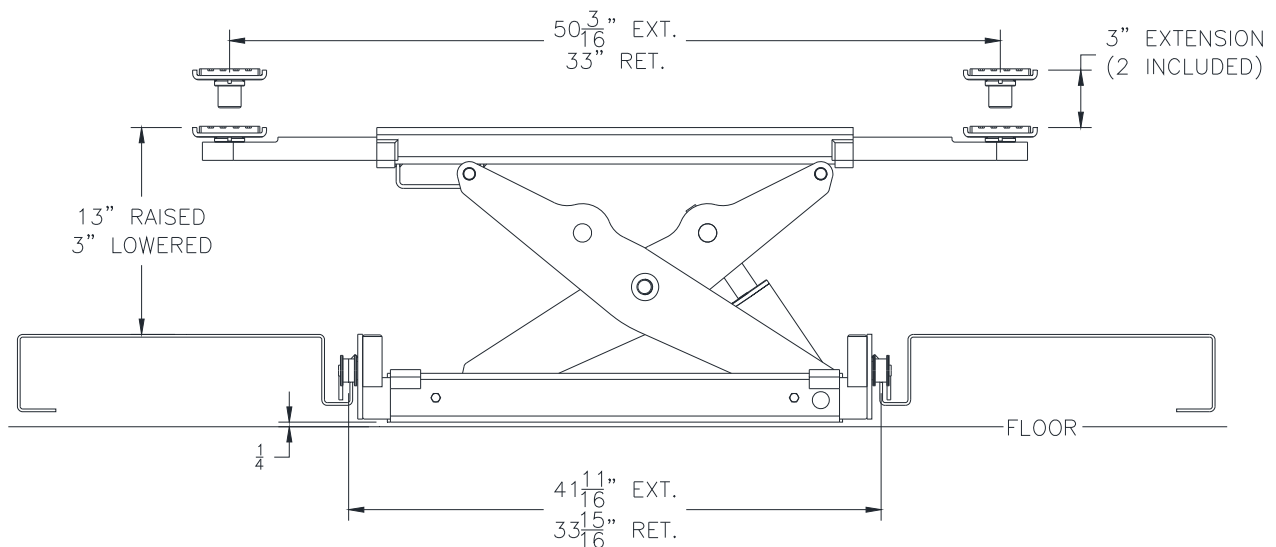

**Fig. 1**

## **INSTALLATION**

- 1) Place jack assembly on lift rack rails.
- 2) Once side members are adjusted and jack is centered between the rails, tighten the (4) hex bolts (2 per side) to lock in place, Fig 2.

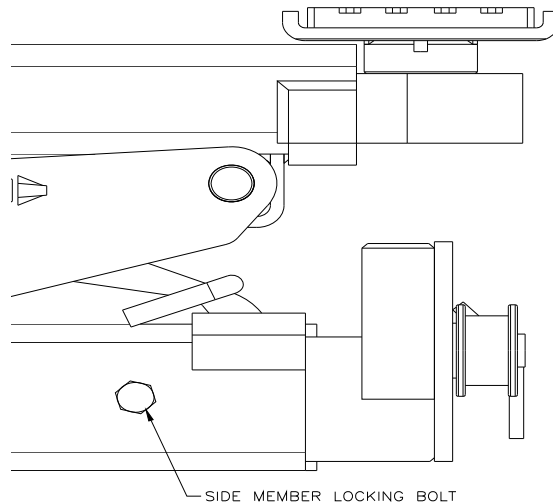

**Fig. 2**

## **Operation**

**Note:** Before lifting a vehicle, operate the jack through a couple of cycles to become familiar with the controls.

- 1) Roll jack forward before moving vehicle on lift rack. Be sure vehicle is centered on rack, apply parking brake and chock wheels.
- 2) Roll jack(s) to the vehicle manufacturer's recommended pick-up points. Extend lift pad arms to proper lift points. Use lift pad spacers if necessary.
- 3) Raise jack by pumping the jack handle.
- 4) Raise vehicle to desired height.
- 5) Lower jack onto lock.
- 6) To lower jack completely, raise off of lock and turn the valve handle counter clockwise. Push lift pad arms in, remove lift pad spacers (if used). Roll jack forward before moving vehicle off rack.

## **Maintenance**

**Daily:** Inspect jack and it's components for damage or excessive wear. Replace parts as required. See parts list.

Inspect hydraulic system for leaks.

**Annually:** Check hydraulic pump fluid level. When jack is completely lowered remove breather plug and check oil level. Oil should be at top of filler plug hole.

## **IMPORTANT!**

Failure to keep lift free of corrosive agents and solvents will lead to reduced service life, which could result in property damage and/or personal injury. If any problems are encountered, contact your local service representative.

**Parts Breakdown**

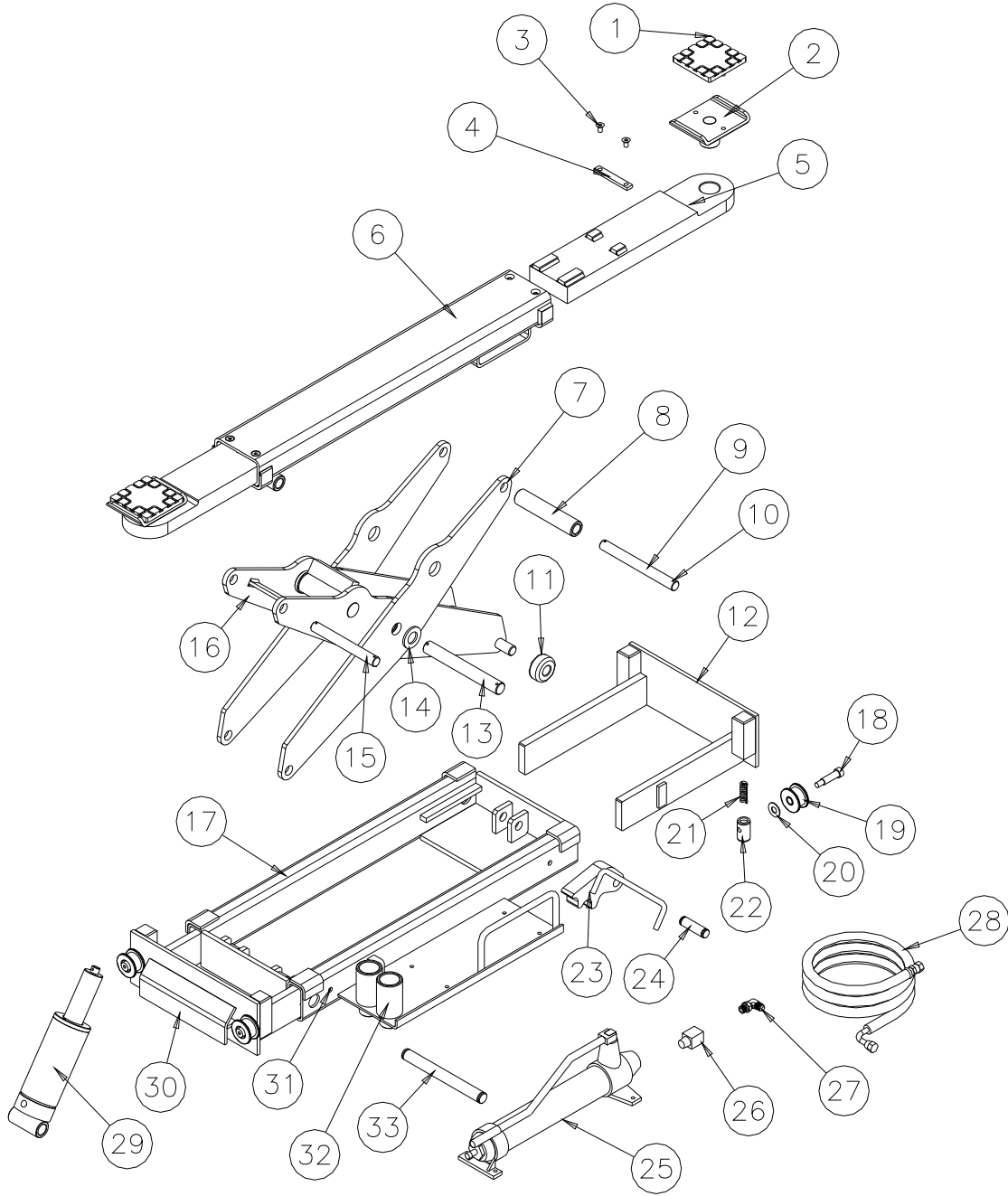

Model QRJ03H  
Installation, Operation and Maintenance Manual

Item Number	Part Number	Qty/Jack	Description
1	A11052	2	Rubber Insert
1A	VS10-35-05	4	M6 Nylon Locknut
2	RJ45-04	2	Foot Pad
3	VS10-31-08	4	M8 x 12 Flat Head Screw
4	RJ3-5-19	2	Stop Bar
5	RJ3-5-02	2	Arm
6	RJ3-5-01	1	Sleeve
7	RJ3-5-07-00	2	Outer Scissor Plate
8	RJ3-5-03	1	Upper Pin Roller
9	RJ3-5-13	1	Upper Pin
10	VS10-20-10	6	5mm Roll Pin
11	RJ3-5-18	2	Roller
12	RJ3-5-15	2	Side Member Weld
13	RJ3-5-08	1	Main Pin
14	RJ3-5-07-03	2	Spacer Washer
15	RJ3-5-12	1	Upper Pin, Fixed End
16	RJ3-5-06-00	1	Internal Scissor
17	RJ3-5-11-00	1	Jack Body
18	RJ6-27	4	Shoulder Bolt
19	RJ6-17	4	Wheel
20	RJ6-24	4	Nylon Washer
21	RJ6-26A	4	Compression Spring
22	RJ6-25	4	Carrier
23	RJ3-5-16	1	Lock
24	RJ3-5-20	1	Lock Pin
24A	RJ3-5-35	2	16mm Snap Ring
25	RJ3-5-31-00	1	Hand Pump
26	RJ45-30-00	1	Flow Restrictor Assembly
27	JSJ3-10-05	1	3/8-18 NPT x M14x1.5 90 Deg. Hyd. Fitting
28	RJ45-21	1	Hydraulic Hose
29	RJ3-5-09	1	Cylinder
29A	RJ6-22	1	Elbow fitting @ Cylinder
30	RJ3-5-15-00	2	Side Member Assembly
31	X10-077	4	M10 x 25 HHCS
31A	RJ6-38	4	M10 Hex Nut
32	RJ6-05	2	3" Stack Pad
33	RJ3-5-14	1	Cylinder Pin
33A	RJ6-36	2	15mm Snap Ring

**IMPORTANT!**

Replace all worn or broken parts with genuine **Quality Lifts Inc.** parts.  
Contact your local Quality Lifts Parts Distributor for pricing and availability.  
**(Call Quality Lifts Inc. (502) 583-5438 for the Parts Distributor in your area)**

# WARRANTY REGISTRATION FORM

SERIAL # \_\_\_\_\_ INV. DATE: \_\_\_\_\_

DISTRIBUTED BY: \_\_\_\_\_

ADDRESS: \_\_\_\_\_

CITY: \_\_\_\_\_ STATE: \_\_\_\_\_ ZIP: \_\_\_\_\_

## CUSTOMER INFORMATION

COMPANY NAME: \_\_\_\_\_

CONTACT: \_\_\_\_\_

PHONE NUMBER: \_\_\_\_\_

ADDRESS: \_\_\_\_\_

CITY: \_\_\_\_\_ STATE: \_\_\_\_\_ ZIP: \_\_\_\_\_

**Please remit form to:**

**Quality Lifts  
P.O. Box 3972  
Louisville, KY 40201  
(877) 771-5438 office  
(502) 583-5488 fax**

This form must be received by Quality lifts for warranty to become effective. !!