

# COMPSTONE



Composite Building Materials



## Composite Stone Veneer

### Installation Guide

# Composite Stone Veneer Installation Guide

## Contents

Introduction & Overview—	3
Required Tools—	4
Optional Tools—	4
Attachment Guidelines: Walls and Framing—	5
Attachment Guidelines: Masonry—	6
Installation: Single Surface (No Corners)—	7
Installation: Using Corner Pieces—	8
Installation: Mitering Corners—	9
Addressing Windows and Openings —	10
Adding Stone Receptacle Boxes—	11
Installing Ledger—	12

# Introduction & Overview



**Ledger**



**Panel**



**Trim**



**Receptacle  
Box**



**Corner Piece**

## Getting Started

Thank you for your purchase of our CompStone Composite Stone Panels. We know that you will enjoy these products, and along the way, should you have any questions or concerns you may reach us at [Support@CompStone.com](mailto:Support@CompStone.com). These panels can be used in a variety of applications. Our panels can be installed literally anywhere you want a custom look. Interiors, exteriors, fireplaces, fences, basements, kitchens etc. We have developed this guide to help you through the installation of your new panels.

## Before Installing:

Do not lay panels directly in sunlight or store upright as this may cause the panels to warp.

The manufacturer does not provide any installation services, other than the guidelines contained in this document.

CompStone composite panels, for exterior applications it is recommended that a minimum of a house wrap, such as Tyvek, be used under the panels on exterior projects. Please verify you are in accordance with any local building codes in regards to moisture barrier requirements.

## Helpful Tips:

Always stagger your seams, this will break up the pattern and make the installation look more natural. Use a small paintbrush to create texture on the caulk seams in order to create a more natural look. You may need to use a file to fine tune the fit of the interlocking panels.

 When using power tools, always wear safety glasses, ear plugs, and a dust mask.

 It is the responsibility of the installer to ensure that the products are installed in accordance with these instructions and any applicable building codes.

# Required Tools

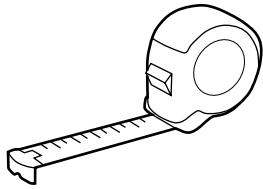

**Tape Measure**

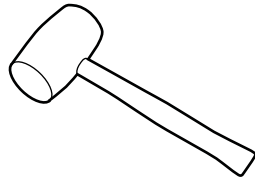

**Rubber Mallet**



**Level**

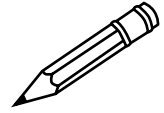

**Pencil**

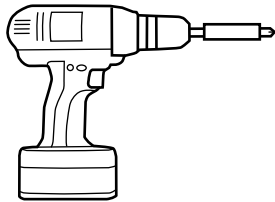

**Drill with Screw Tip**

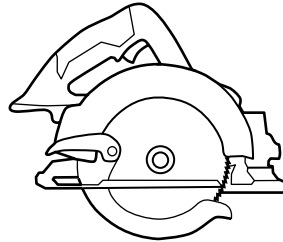

**Saw with a Fine Tooth  
Wood Blade**

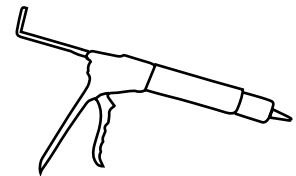

**Latex Caulk**

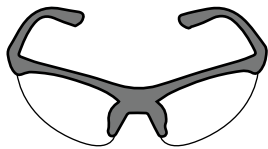

**Safety Glasses**

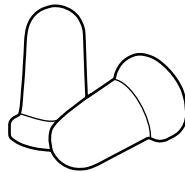

**Ear Plugs**

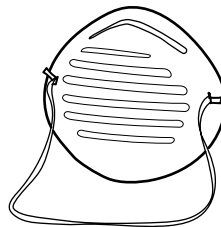

**Dust Mask**

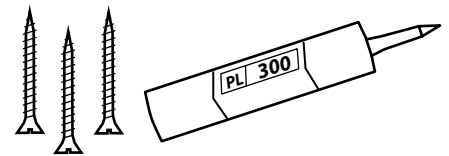

**Screws and/or  
Polyurethane Foam  
Board Adhesive\***

# Optional Tools

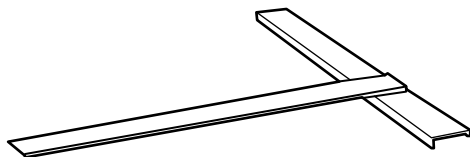

**Drywall Square**



**Marker**



**File**



**Small  
Paintbrush**

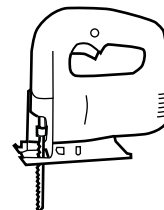

**Jig Saw**

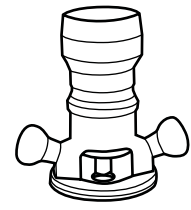

**Hand held  
Router**

\*See Attachment (pg.5) for details on determining specific requirements for screws and adhesives.

# Attachment Guidelines: Walls and Framing

Use the following guidelines to determine the materials you will need for attachment. It is recommended that a minimum of a house wrap, such as Tyvek, be used under the panels on exterior projects. Adhesive may not be as effective in combination with the water resistant sheet, use screws only in this application.

## Existing Walls with Studs: Screws & Adhesive

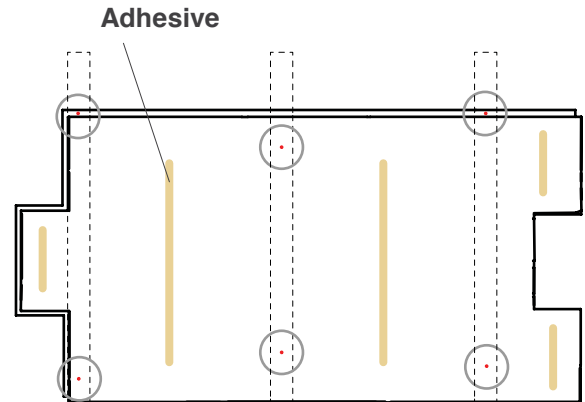
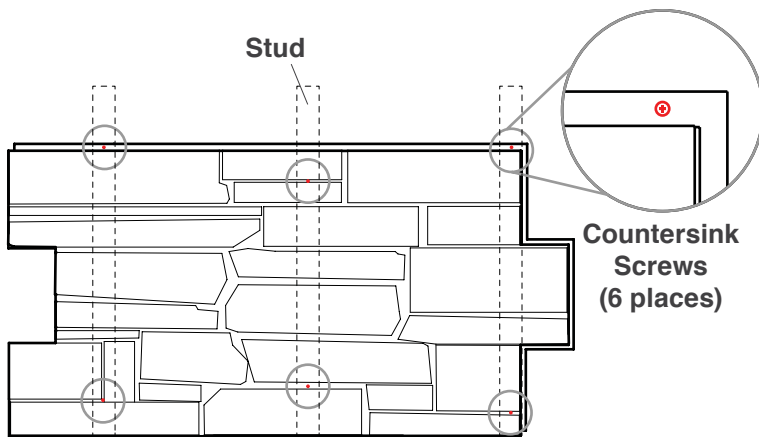

### Tips:

Locate and mark your studs first. Only fasten screws to studs.

Dry-fit panels on the wall and mark stud location on your panels using a pencil

Pre-drill and counter sink screw holes in locations on the panel where screws will be less noticeable such as the gap between two stones.

Use galvanized screws for exterior walls and Sheetrock screw for interior walls.

For adhesive: use construction grade polyurethane foam board adhesive(PL 300 or higher). Apply the glue in vertical lines only to ensure that no water buildup will occur behind the panels in exterior applications.

## Framing: Screws Only

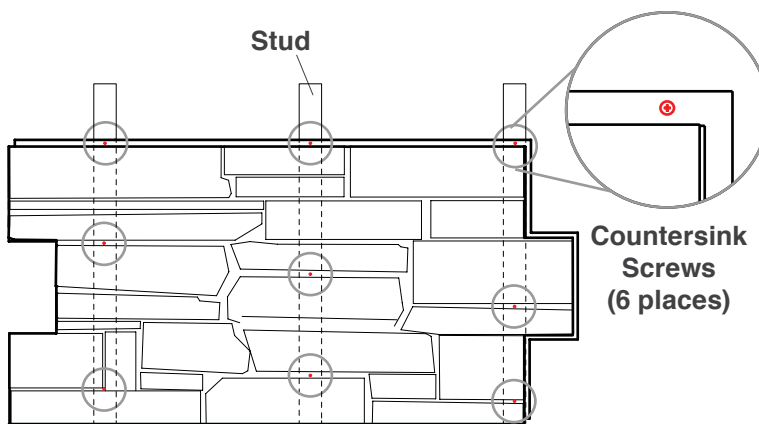

# Attachment Guidelines: Masonry

When installing the panels over masonry block (or brick) it is best to make sure that the area to be covered is cleaned and allowed to dry. We suggest that you use a combination of Tap-Con (concrete) screws and a polyurethane approved adhesive such as PL-300 or above.

Dry fit your pre-drilled panels to your masonry surface and mark where you will be drilling holes for the Tap-con screws. Apply the adhesive in vertical lines and place the panels against the masonry and hold in place until the adhesive begins to bond. Then use the Tap-Con screws to firmly adhere the panel to the wall.

## Masonry Attachment: Tap-con Screws

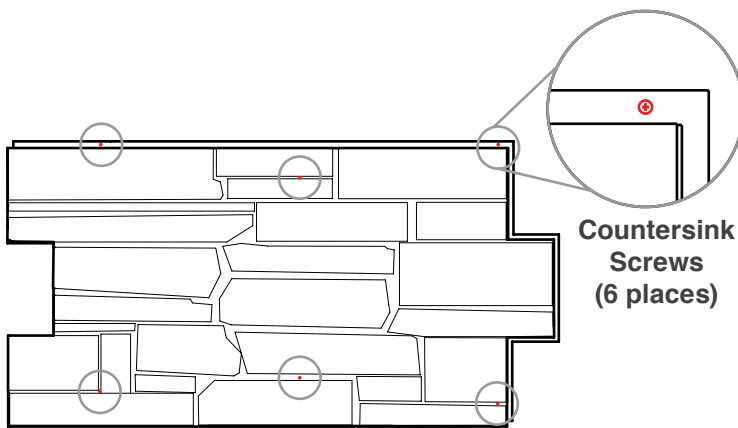

Countersink  
Screws  
(6 places)

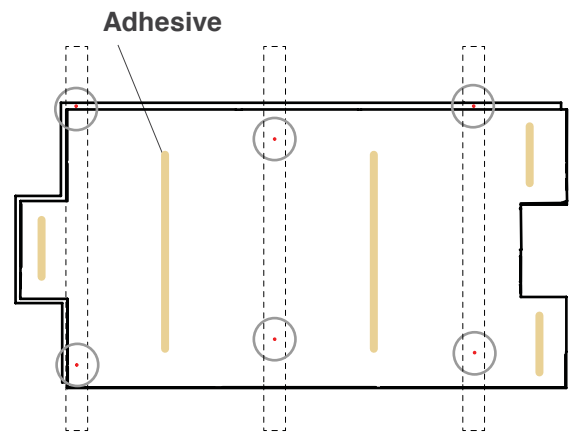

### Tips:

When using Tap-Con screws, pre-drill your holes into the masonry.

You can attach furring strips with concrete cutting nails to the wall that will allow you to adhere the panels to these strips with standard hot dip galvanized screws.

Pre-drill and counter sink screw holes in locations on the panel where screws will be less noticeable such as the gap between two stones.

Apply the adhesive in vertical lines only to ensure that no water buildup will occur behind the panels.

## Masonry Attachment: Galvanized Screws

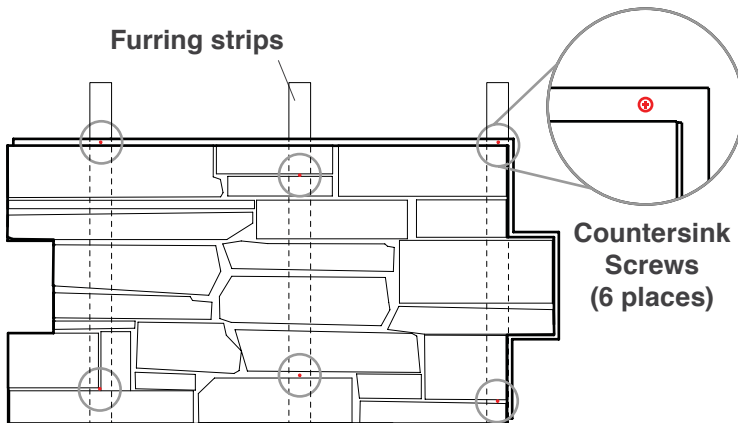

Furring strips

Countersink  
Screws  
(6 places)

Furring strips create a gap between the panels and the masonry. We recommend installing a ledger to cover this gap.

# Installation: Single Surface (No Corners)

- 1 Cut a straight edge on the left side of the first panel to allow for a flush beginning.

Cut the panel smooth side up

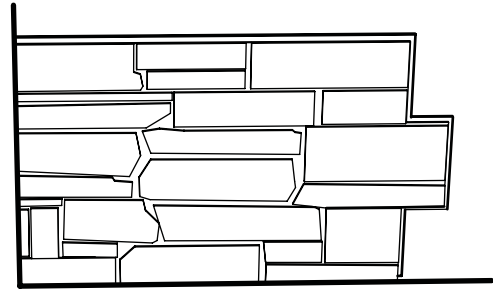
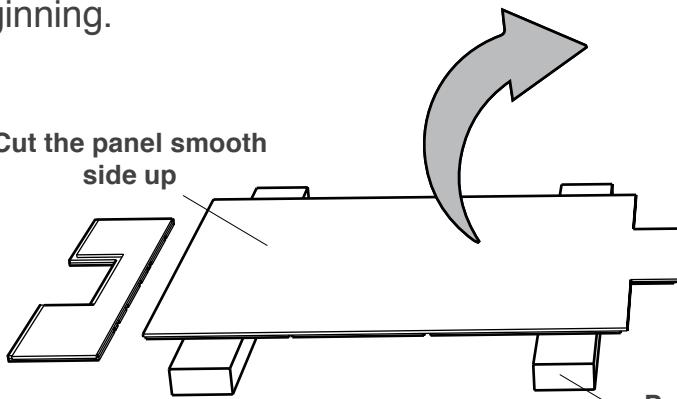

- 2 Starting on the bottom left, attach panel to surface.

Protect textured side from scuffing.

- 3 Interlock next panel by gently tapping with a rubber mallet until it fits tightly against the first panel.

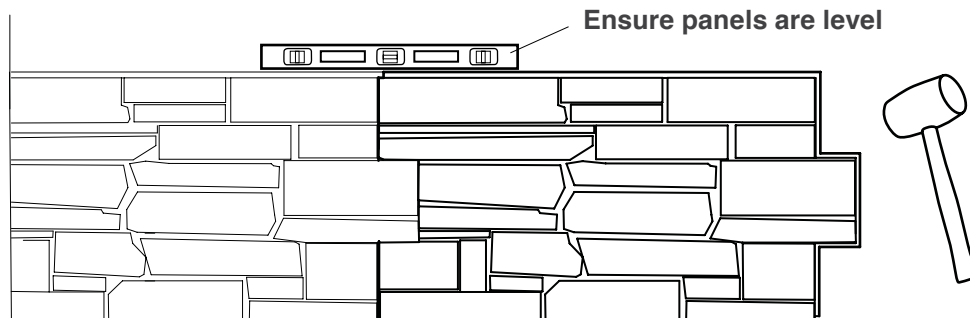

Ensure panels are level

- 4 Continue until the remaining distance is less than the length of one panel. Measure the remaining distance and cut the final piece accordingly.

Using the piece from end of last row ensures a staggered seam, which helps your install look natural.

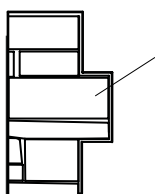

Caulk seams after installation is complete as needed



# Installation: Using Corner Pieces

- 1** Attach first corner piece to surface.

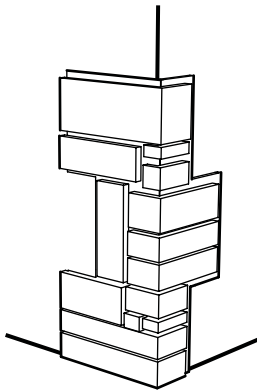

- 2** Interlock next panel to first corner piece by gently tapping with a rubber mallet until it fits tightly against the first panel.

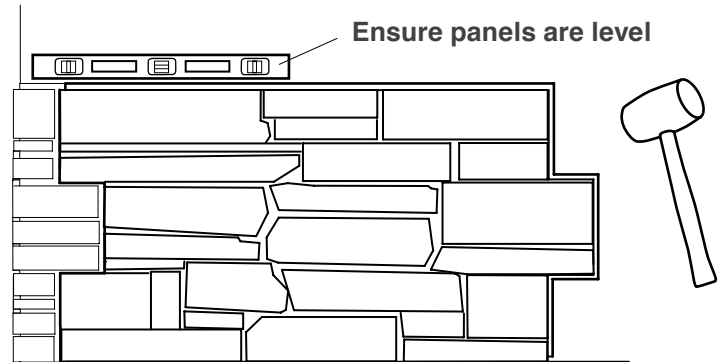

- 3** Continue in this fashion until the remaining distance is less than the length of one panel. Dry fit your last panel. Cut off any excess.

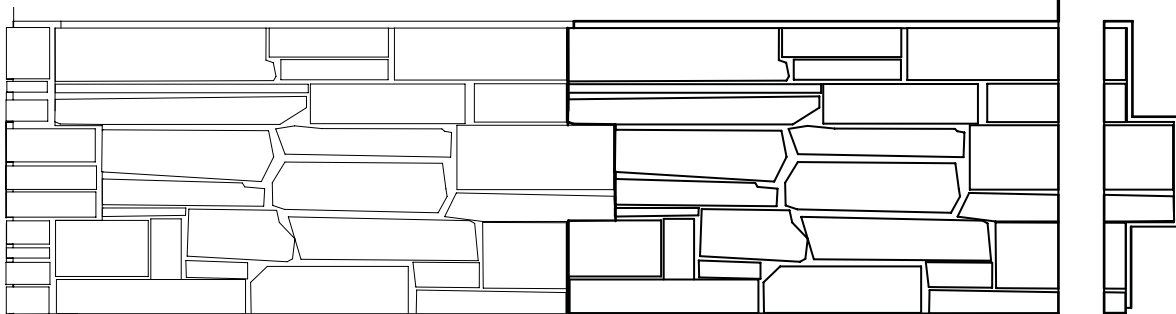

- 4** Using a corner piece, trace its contour onto your last panel by carefully aligning the edges. Then, use your jigsaw to cut out the shape. Proceed with attachment.\* For the next row, work from right to left for a staggered seam.

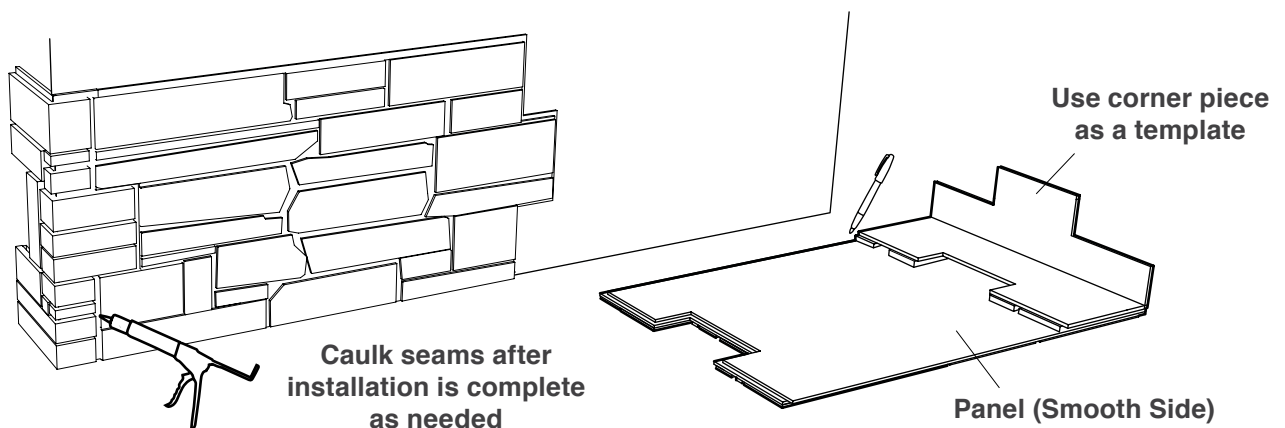

*\*for an advanced fit you can use a hand held router to create an under-lapping flange.*



# Installation: Mitering Corners

- 1** Select a corner to begin. Cut your first panel in half with two, 45° miter cuts to produce the mitered corner (see image below). Attach both pieces to the corner. It may be necessary to smooth edges with a file, and fill in caulk as needed.

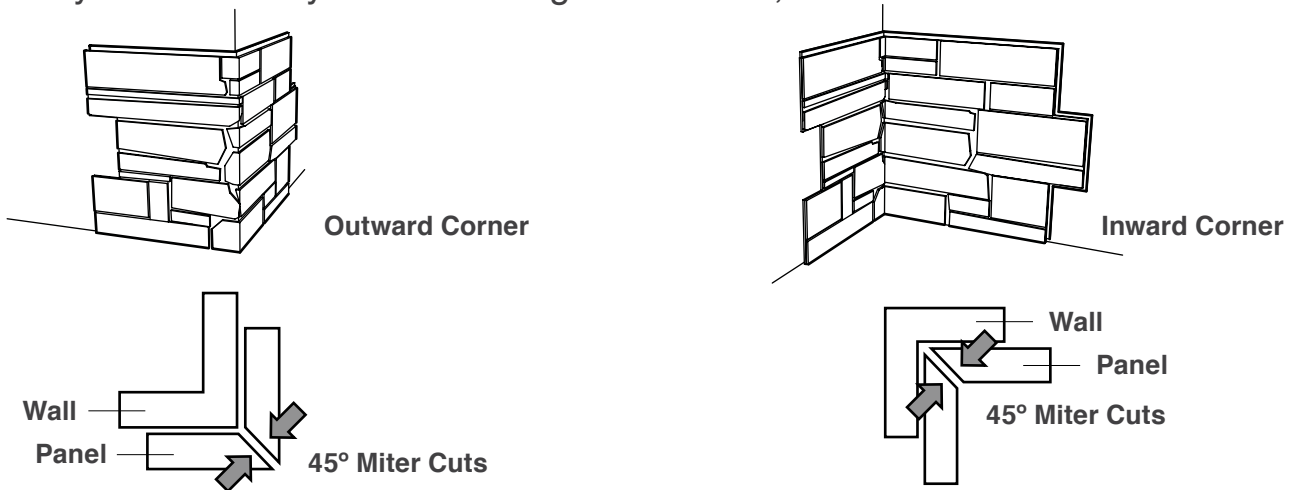

- 2** Interlock next panel to first piece by gently tapping with a rubber mallet until it fits tightly against the first panel.

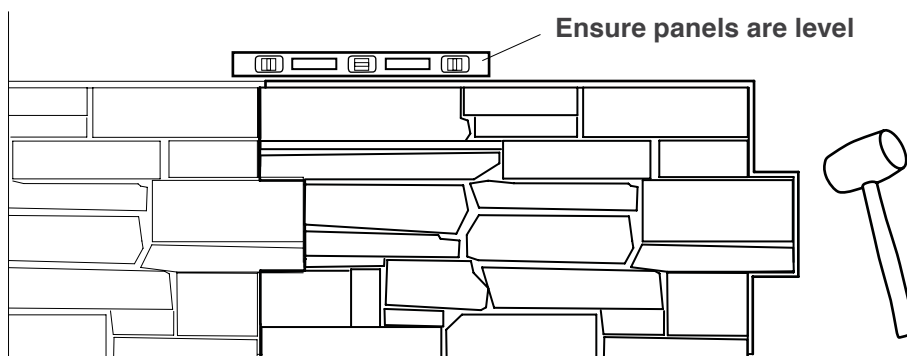

- 3** Continue in this fashion until the remaining distance is less than the length of one panel. Dry fit your last panel. Mark the back of the panel where the wall ends. Make your 45° cut on this panel before attaching to the wall.

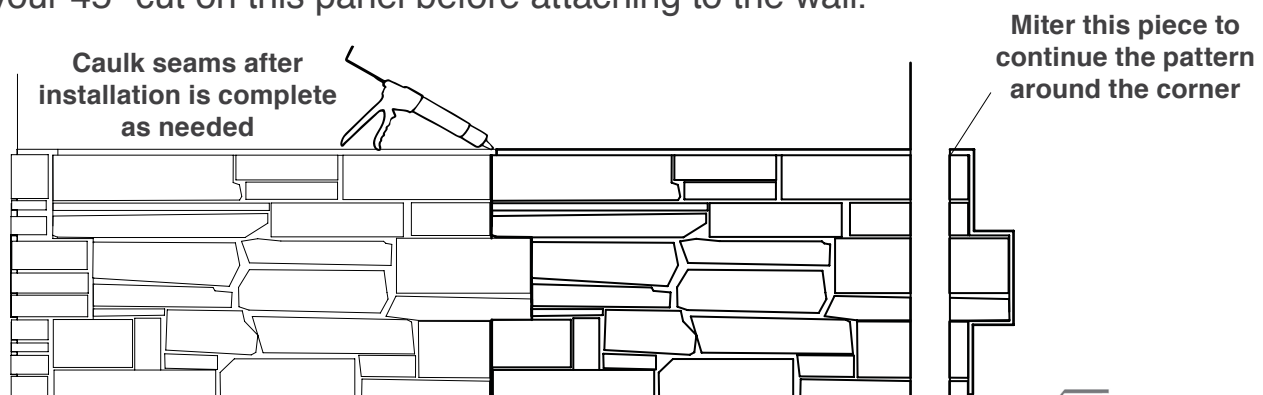

# Addressing Windows and Openings

Trim pieces are available to help you finish edges where your CompStone panels intersect with openings such as windows and doors. Trim pieces can also be used to finish corners. You can use trim and ledger pieces in combination to create a finished exterior wainscot application. The installation process is similar to using corner pieces (see page 9).

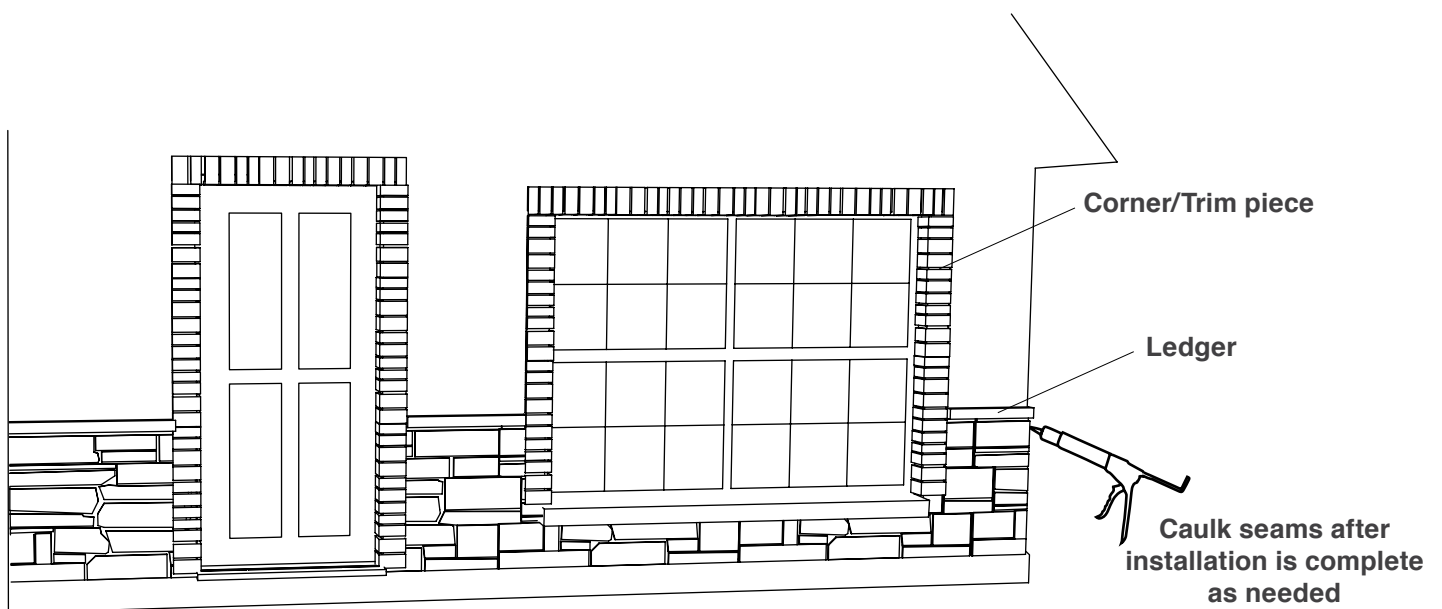
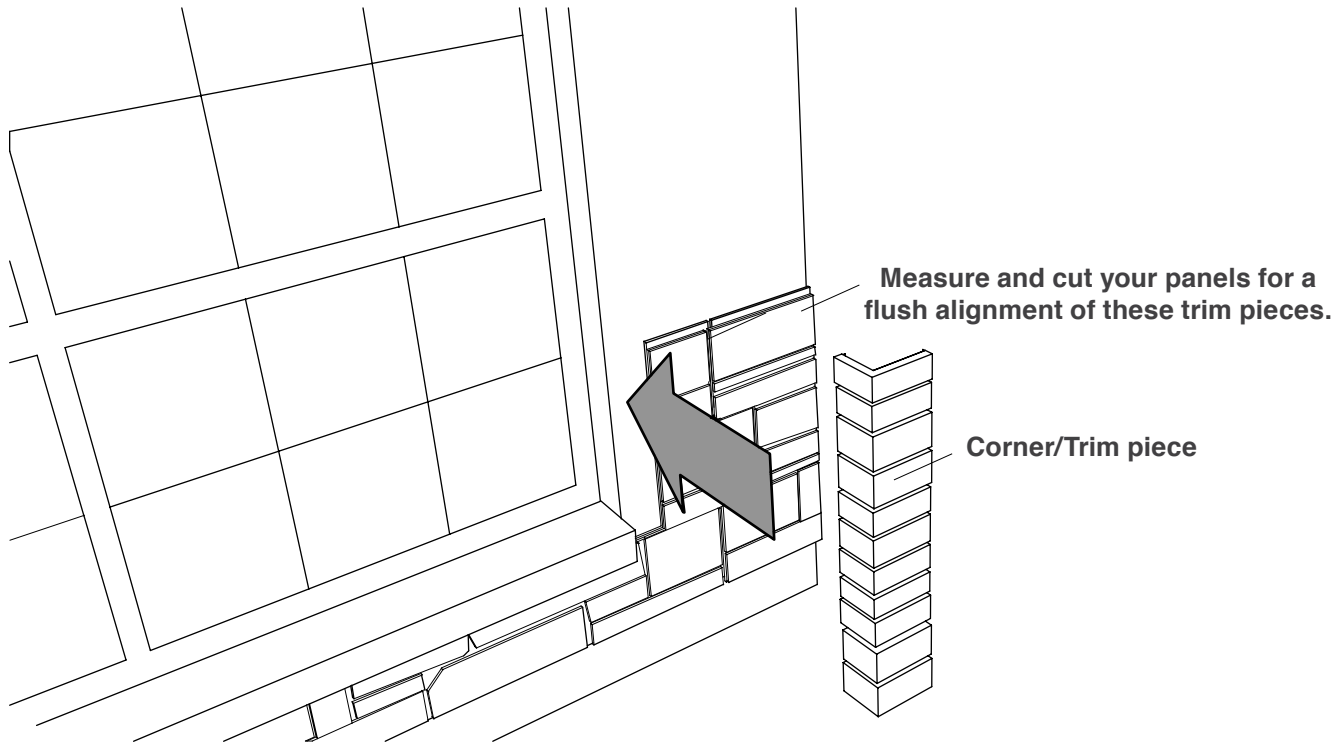

# Adding Stone Receptacle Boxes

- 1** Measure and cut appropriate size hole in your panel using a saw or other power tool.

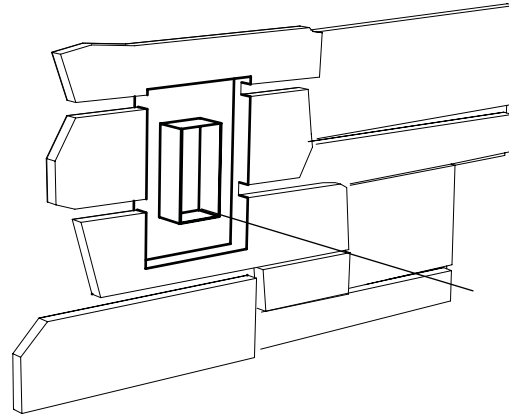

**A/C  
Receptacle**

- 2** Apply adhesive to the wall and put stone trim in place.

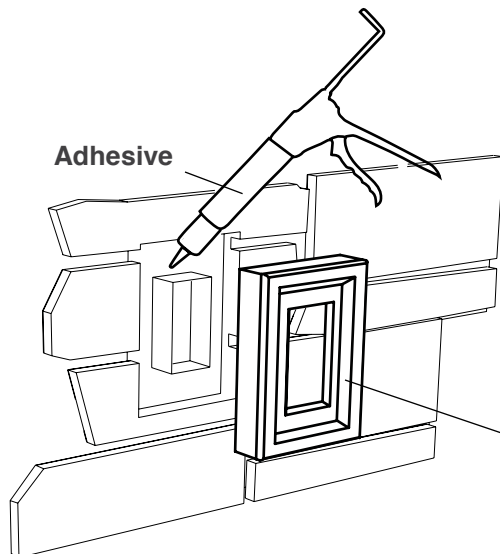

**Receptacle  
Box**

- 3** Caulk the gap between the receptacle box and the panel.

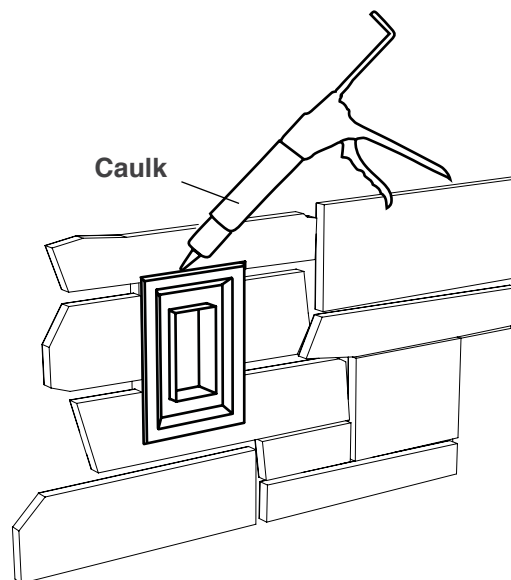

# Installing Ledger

For wainscot applications attach Ledger along top edge of panels with pre-drilled countersunk screws. Finish by filling in holes with caulk.

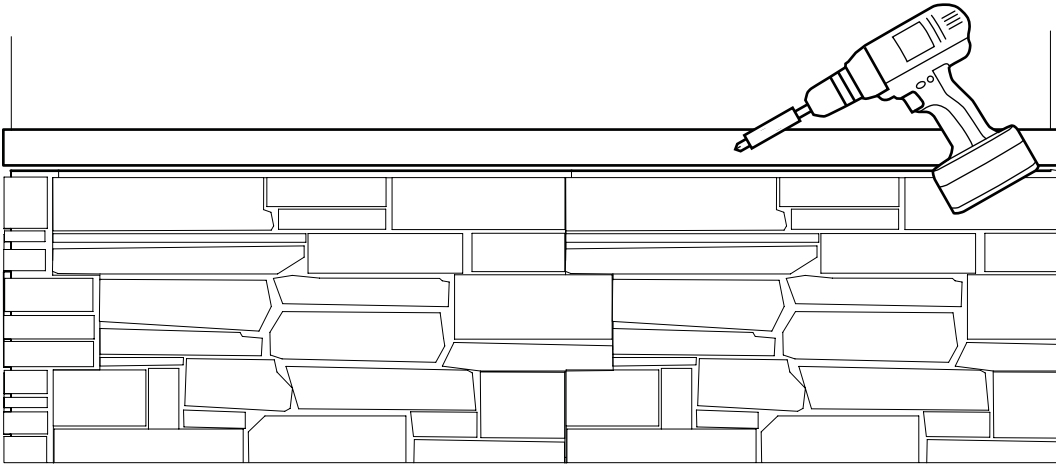



**Please read entire instruction manual thoroughly prior to the installation of your composite panels. The details included in this manual are guidelines only. CompStone is not responsible for damage to your structure, substrate, or any damage caused by improper installation.**

**If you have any questions please contact our technical department:  
[Support@CompStone.com](mailto:Support@CompStone.com)**