

ROSS
1879 VALVE

WASTEWATER VALVES



**MODEL 70SWR SERIES
PRESSURE RELIEF
SURGE CONTROL
BACK PRESSURE SUSTAINING
PUMP CONTROL**

Ross wastewater control valves are built tough, for tough jobs.

Ross Valve's 70SWR series of control valves are designed and manufactured based on our proven piston style design, with special modifications for optimal performance in municipal and industrial wastewater applications. These include seals and seat materials better suited for service under these harsh conditions, and an unobstructed waterway to allow the media to flow more freely. As with all Ross Valves, the design is highly customizable for a variety of applications. Some of the more standard configurations include:

Relief (70SWR): Used to protect lines against excessive pressure caused by too rapid or erroneous valve closing, starting or stopping a pump, and even against a power failure. Supplied with an adjustable cushioned closing device to prevent slamming.

Surge Anticipating (70SWR-E): Used to protect systems against excessive pressure surges like the 70SWR, but offers the additional benefit of anticipating upcoming surges. Since surges typically travel at 4000 ft/s, this valve incorporates an advanced pilot system that is activated by anticipating high pressure surges from the preceding low pressure waves. Supplied with pneumatic or hydraulic controls powered via a separate power source (water or compressed nitrogen). Optional control panels are available.

Back Pressure Sustaining (70SWR-BP): Used to maintain a minimum preset value on the inlet of the valve. This valve can be installed on the pump discharge to keep a pump on a curve, or on the end of a line (with free discharge) to maintain a certain pressure in the line. The valve will be normally closed and only opens to the degree it needs to maintain the set pressure value on the valve inlet.

Pump Control (70SWR-S): Used to provide the most proactive approach to surge control, this valve minimizes pump start and stop surges by coordinating valve and pump operation, to prevent surges before they can start. Includes a built-in check feature to prevent reverse flow and adjustable speed controls for both opening and closing. Typically supplied with an electric actuator. Optional control panels are available.

Control valves perform a critical function in water lines. In wastewater lines, their function is even more important. Trust the accuracy and reliability of your system's performance to a valve that is always up to the task – the Ross 70SWR series.

Buy American



All Ross Valves are
100% ARRA Compliant



Suitable for use with a wide variety of fluids including:

- Wastewater
- Raw Water
- Sewage
- Greywater
- Pulp and more

CONSTRUCTION

ROSS 70SWR SERIES

SIZES

2" – 48" (50mm – 1200mm).

DESIGN

Based off our proven piston design, and modified for use with untreated water, the Ross line of wastewater valves is designed for accuracy, performance, and long life.

KEY FEATURES

- 1 Stainless steel seat assembly and seat ring resist wear.
- 2 Fully Enclosed Springs for safety.
- 3 Single Adjusting Screw for accurate alignment and precise operation.
- 4 Cushioned Closing Device prevents slamming.
- 5 Angle (90°) and globe (inline) style bodies available (epoxy-coated cast iron).

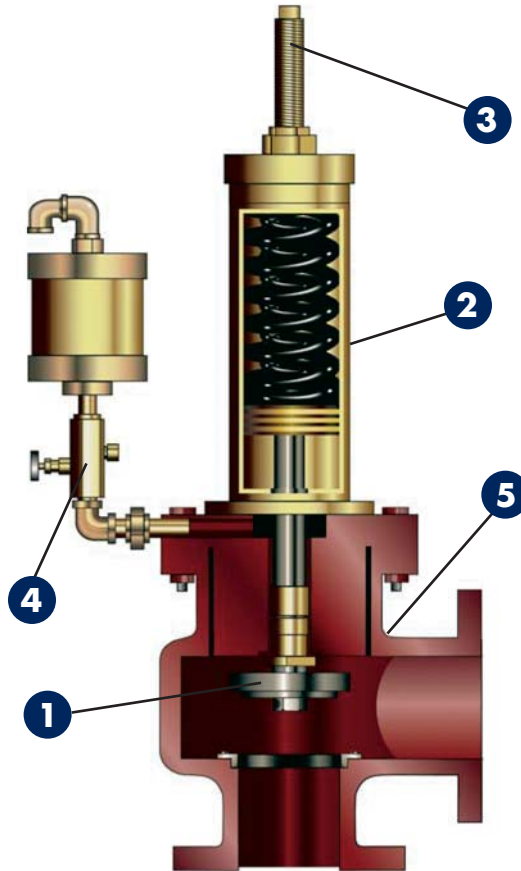

Model 70SWR
Wastewater Relief Valve
(Angle Body Shown)

ADDITIONAL FEATURES & BENEFITS

- Rugged piston style construction provides dependable operation and peace of mind.
- Every internal part is replaceable through the top cap, without removing the valve from the line.
- Compact design suitable for new applications or retrofits. Custom dimensions also available.
- Valve-mounted gauge cock for operational and testing purposes.
- Internal and external NSF-approved epoxy coating.
- All engineering, manufacturing, and testing done in-house.

As with all Ross Valves, the 70SWR series valves are highly customizable. Some of the common options include:

- **Pressure setting indicator** — illustrates initial setting as well as a calibrated pressure scale.
- **Limit switch assembly** — provides an electrical contact indicating valve opening and/or closing.
- **Electronic solenoid control** — to override hydraulic controls
- **Power fail override options** — forces the valve to go to a certain position in the event of a power failure
- **Relay style control panel** — for conventional pump control
- **Model MC2001P panel** — PLC-based electronic pump control panel with message center display.
- **Model MC2000S panel** — PLC-based electronic surge control panel with message center display.
- **Special dimensions** — flanges and laying lengths can be customized for an exact fit
- **Special materials** — available as needed

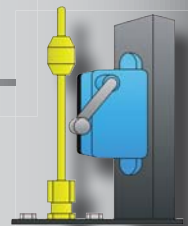

SPECIFICATIONS

70SWR SERIES CONTROL VALVES FOR WASTEWATER

APPLICATION

70SWR — The wastewater relief valve is a combination direct acting and hydraulically operated control valve using a hydraulic self-contained oil cylinder as a dampening device. The valve shall be normally closed and shall open quickly when the inlet pressure exceeds the spring setting. The valve will modulate between 0% and 100% open in order to assure the valve's inlet pressure remains below the set point. The valve shall close at a slow and controlled speed, which is field adjustable, via the self-contained hydraulic oil cushioned cylinder.

70SWR-E — The wastewater surge control valve is a combination direct acting and hydraulically operated control valve that opens quickly when the inlet pressure exceeds the spring setting, then closes slowly via an adjustable dampening device. In addition, the valve incorporates an electrical control circuit which uses a low pressure signal to open the valve in anticipation of the surges associated with water hammer. After the valve relieves the necessary pressure, it slowly resumes a fully closed position.

70SWR-BP — The wastewater back pressure sustaining valve is a combination direct acting and hydraulically operated control valve. The valve shall be normally closed and shall open when the inlet pressure exceeds the spring setting. The valve will modulate between 0% and 100% open in order to assure the valve's inlet pressure does not fall below the set point.

70SWR-S — The wastewater pump control valve is electrically actuated and shall receive a control signal to slowly bring a pump online and offline to prevent surges. The controls consist of an electric actuator including, but not limited to, the electric motor, reduction gearing, mechanical overload torque switches, and automatic de-clutchable handwheel. The valve shall also prevent reverse flow in the event of a power failure by means of an independent lower shaft that drops down into the valve seat if there is a sudden loss of inlet pressure. Dual independent speed control valves shall be provided (field adjustable).

PHYSICAL & CHEMICAL PROPERTIES

70SWR Series — Valve body and cap(s) shall be constructed of gray iron castings that conform to ASTM Specification A 126 Class B. Internal bronze components shall conform to ASTM Specification B-584. Internal Stainless Steel components shall conform to ASTM Specification A- 7 43 Grade CF-8 or CF-8M.

The seat ring shall be grade 300 series stainless steel and shall be held in place via grade 300 series stainless steel fasteners. The seat support assembly shall be grade 300 series stainless steel. The control piping shall be rigid red brass, no less than 0.5" in diameter.

The flanged assemblies shall conform to ANSI standards for wall thickness of body and caps, and flange thickness and drilling, subject to other specified standards.



DESIGN

70SWR Series — The valve shall be globe (inline) or angle (90°) body with flanged end connections. It shall contain a single full-ported seat, with seat bore equal to size of valve. The minimum travel of the piston shall be equal to 25% of the diameter of the seat. For true alignment (to correct lateral thrust and stem binding), the piston shall be guided above the seat a distance equal to no less than 75% of the diameter of the seat. The piston shall be cushioned and so designed as to insure positive closure. The main valve shall be packed with a resilient seat packing and Buna o-ring seals to insure tight closure and prevent metal to metal friction and seating. The design shall be such that repairs and dismantling internally of main valve may be made without its removal from the line.

A mechanical scraper ring shall be utilized to protect the internal seals. The valve shall be furnished with an inlet side gauge-cock for receiving gauges and testing purposes. The external controls and all associated rigid brass piping and fittings necessary for proper operation (except the oil for the hydraulic chamber) shall be factory assembled and furnished with the valve.

70SWR, 70SWR-BP — The springs shall be enclosed in a protective chamber and shall be concentric to the valve piston to insure proper alignment.

70SWR-E — The springs shall be enclosed in a protective chamber and shall be concentric to the valve piston to insure proper alignment. For surge anticipation, a solenoid pilot valve, pressure transducer, control panel, and auxiliary pressure supply must be included with the valve.

70SWR-S — The valve shall incorporate a two piece stem design, with a lower stem that is free to move into the closed position independently of the actuator in the event of a power failure. The actuator shall be concentric to the valve piston to insure proper alignment.

PAINT

70SWR Series — Ferrous surfaces of the valve shall be coated with NSF Certified Epoxy (Tnemec Series FC20) in accordance with ANSI/NSF Std. 61, and conforming to AWWA D102 Inside System No. 1.

TESTING

70SWR Series — A trio of tests shall be performed on the completely assembled valve prior to shipment. These shall include a hydrostatic test of up to two (2) times the working pressure (maximum 500 psi testing pressure), a tight seating test, and a performance test for simulated field conditions. The tests may be witnessed by the customer/engineer or representative.



NOTE: The Ross Valve Mfg. Co., Inc. reserves the right to modify valve construction which will result in equal or superior performance to existing designs. These modifications may be made at any time and at the sole discretion of the manufacturer.

HEADLOSS GUIDE

ROSS 70SWR SERIES

INSTRUCTIONS

- 1 Locate the desired headloss along the vertical axis, for the appropriate type valve.
- 2 Follow the line horizontally until the desired flow is reached (according to the horizontal axis).
- 3 Follow the line vertically down to the nearest angled line to determine the appropriate valve size.

ANGLE STYLE

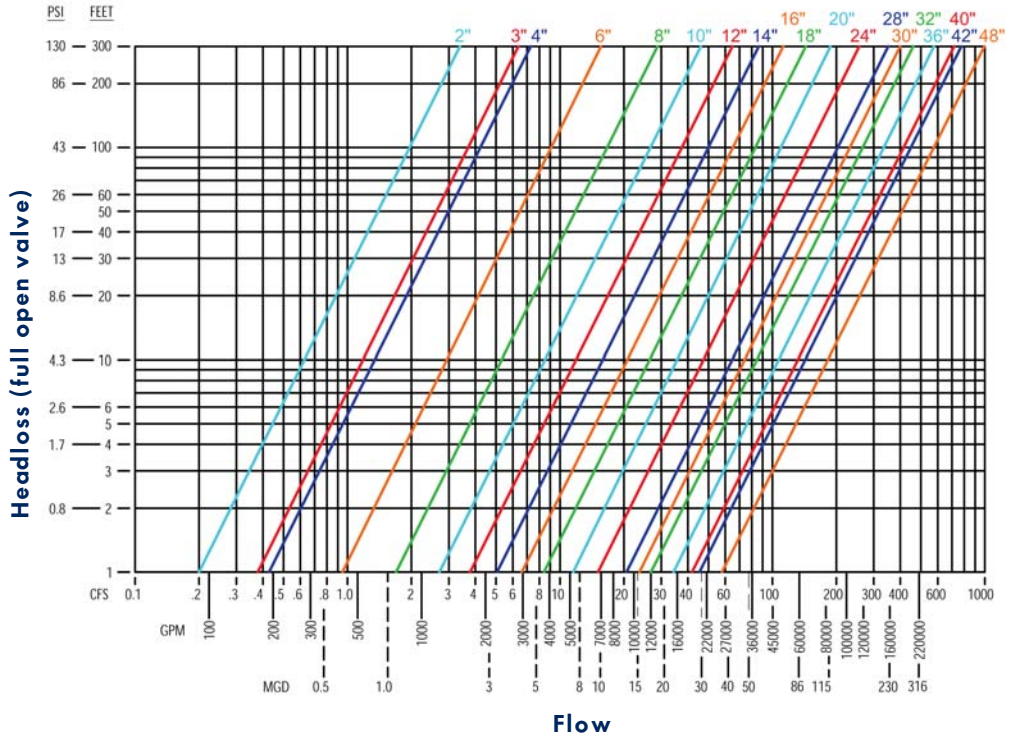
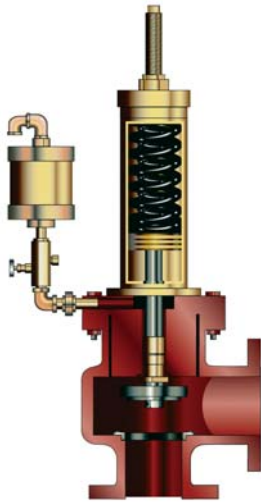

GLOBE STYLE

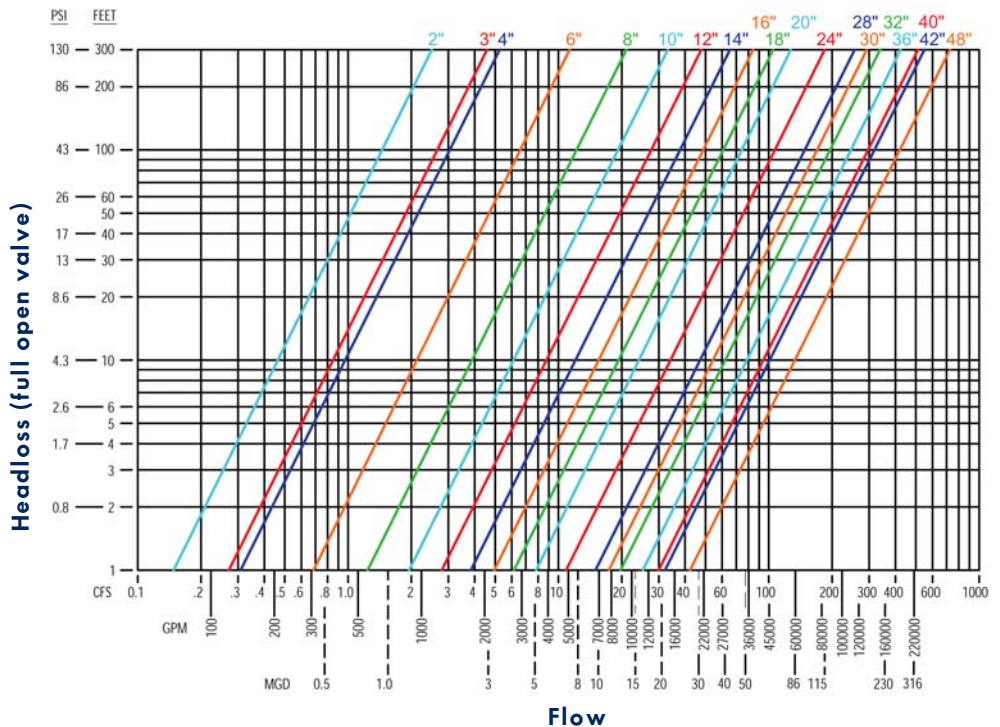
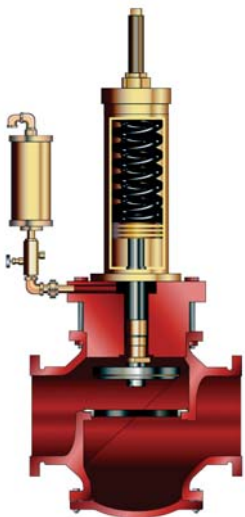

Important note: For valves that use a direct acting design and a spring force (Models 70SWR, 70SWR-E, and 70SWR-BP), the flow through the valve is somewhat dependent on the line pressure. When the line pressure rises to the set point (as dictated by the spring force), the valve will start to open. If the flow through the valve is sufficient to satisfy the pressure requirement, the valve may not open further. However, if the pressure continues to increase, the stem will compress the spring further and the valve will open more to allow more flow. This additional flow may occur at a pressure higher than the set point.

DIMENSIONS AND WEIGHTS

ROSS 70SWR SERIES

ANGLE STYLE (all dimensions in inches)

Valve Size	A		B		C&D	E		F		G*	H	Ship Weight (lbs)	
	125 ANSI	250 ANSI	125 ANSI	250 ANSI		125 ANSI	250 ANSI	125 ANSI	250 ANSI			125 ANSI	250 ANSI
4"	7.5	7.8125	9	10	4.75	8	8.125	6.25	6.5625	30-35	16	245	275
6"	8.625	9.0625	11	12.5	6.625	9.5625	10.125	8	8.4375	30-35	18	360	420
8"	10.5	11	13.5	15	8.75	12.875	13	10	10.5	30-35	20	650	700
10"	12.5	13.125	16	17.5	10	14	14	11.5	12.125	30-35	20	800	895
12"	15	15.5	19	20.5	12	17.25	17.25	12.625	13.125	30-35	24	1,260	1,370
14"	17	17.75	21	23	14	19.25	19.25	14.875	15.625	30-35	24	1,700	1,830
16"	19	19.75	23.5	25.5	15	21	21	16.5	17.25	30-35	24	2,180	2,420
18"	21.25	22.125	25	28	18	23.5	23.5	16.75	17.5625	30-35	36	3,050	3,350
20"	21.25	22.125	27.5	30.5	18	23.5	23.5	18.875	19.6875	30-35	36	3,330	3,630
24"	24.25	25.125	32	36	24	25.75	25.75	20.25	21.125	30-35	36	4,700	5,200
30"	31.875	32.875	38.75	43	26.25	37	37	27	28	30-35	40	9,800	10,800
36"	31.875	32.875	46	50	26.25	37	37	27	28	30-35	40	11,800	12,800

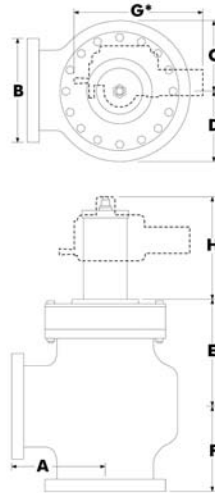

GLOBE STYLE (all dimensions in inches)

Valve Size	A		B		C&D	E		F		G*	H	Ship Weight (lbs)	
	125 ANSI	250 ANSI	125 ANSI	250 ANSI		125 ANSI	250 ANSI	125 ANSI	250 ANSI			125 ANSI	250 ANSI
4"	14	14.375	9	10	4.75	7	7	7	7	30-35	16	235	275
6"	17.75	17.75	11	12.5	6.625	9	9	9	9	30-35	18	375	430
8"	24	24.8125	13.5	15	8.75	12.5	12.5	12.5	12.5	30-35	20	690	750
10"	24.875	24.25	16	17.5	10	14.25	14.25	14.25	14.25	30-35	20	920	1,000
12"	30	31.5	19	20.5	12	15.5	15.5	15.5	15.5	30-35	24	1,375	1,475
14"	34.125	35.75	21	23	14	18	18	18	18	30-35	24	1,770	1,850
16"	37.875	39.25	23.5	25.5	15	21.5	21.5	21.5	21.5	30-35	24	2,400	2,600
18"	41.875	41.875	25	28	18.375	24	24	24	24	30-35	36	3,300	3,500
20"	42.375	42.375	27.5	30.5	18.375	24	24	24	24	30-35	36	3,550	3,800
24"	47	47	32	36	20	25	25	25	25	30-35	36	5,200	5,500
30"	63.75	65.5	38.75	43	26.25	34	34	34	34	30-35	40	9,800	10,800
36"	65	65	46	50	26.25	34	34	34	34	30-35	40	11,800	12,800
42"	82	82	53	53	35	38.25	38.25	40	40	30-35	40	16,300	17,400
48"	88	88	59.5	65	39.125	44	44	43.25	43.25	30-35	40	21,000	22,500

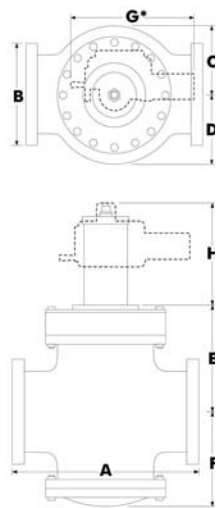

* Various actuator styles and sizes available. Consult factory for details.

ROSS MODEL 28AR

Direct Acting Pressure Relief Valve

SIZES

2", 2-1/2", 3" (50, 65, 80mm)

DESIGN

The 28AR wastewater relief valve has a direct acting design that provides quick response for lower flow requirements.

When placed inline (instead of off a tee connection), the valve may function as a back pressure sustaining valve.

FLOW CAPACITY

This valve has a limited flow capacity due to the direct acting design. The valve opens only as far as the springs compress.

Max recommended flow at 75 psi differential pressure		
2"	2-1/2"	3"
200 gpm	350 gpm	500 gpm

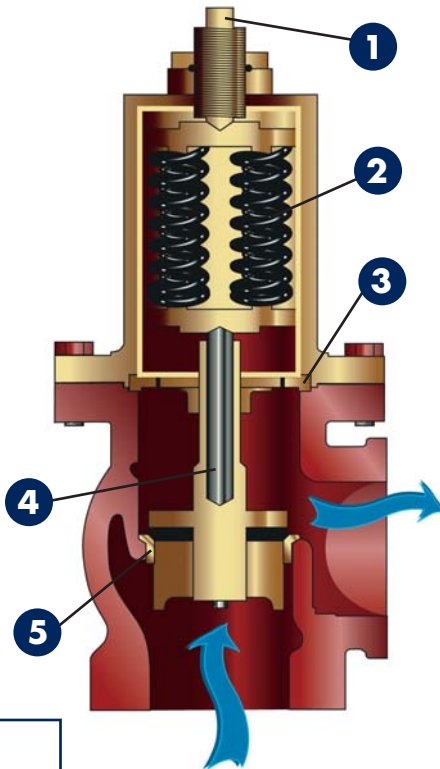

OPERATION

The Ross Model 28AR Pressure Relief Valve utilizes a simple direct-acting design to prevent excessive pressure upstream of the valve.

- Closing:** An adjustable spring load is transferred along the valve stem assembly (#4) to close the valve and prevent fluid from flowing through it.
- Opening:** When the incoming line pressure exceeds the loading of the springs (#2), the stem assembly lifts the seat packing off the valve seat ring (#5) to pass fluid through the valve. Flow through the valve increases as the inlet pressure increases. The guide plate (#3) keeps the stem in proper alignment.
- Adjustment:** Turning the adjusting screw (#1) clockwise will increase the compression on the springs (#2) and increase the relief pressure setting of the valve. Turning the adjusting screw counter-clockwise will decrease the setting.

SPECIFICATIONS

MODEL 28AR DIRECT ACTING PRESSURE RELIEF VALVE FOR WASTEWATER

APPLICATION

The direct acting wastewater relief valve shall automatically open to prevent inlet pressure from exceeding a maximum setting. The valve shall operate such that the inlet pressure is opposed via an adjustable spring loaded piston assembly. When the inlet pressure exceeds the spring loading, the springs compress allowing the piston assembly to open to relieve the excess pressure.

DESIGN

The relief valve shall be angle (90°) body with female NPT end connections, direct piston operated. It shall contain a single full-ported seat, with seat bore equal to size of valve. The valve shall be packed with polyurethane (or other soft material) to insure tight closure and prevent metal-to-metal friction and seating. The design shall be such that repairs and dismantling internally of main valve may be made without its removal from the line. Note: The valve has a limited flow capacity due to the direct acting design (the valve opens only as far as the springs can compress).

PHYSICAL & CHEMICAL PROPERTIES

Valve body shall be constructed of gray iron casting that conforms to ASTM Specification A 126 Class B. Internal bronze components shall conform to ASTM Specification B-584. Internal Stainless Steel components shall conform to ASTM Specification A-7 43 Grade CF-8 or CF-8M. The threaded assemblies shall conform to ANSI standards for Female National Pipe Threads (FNPT).

TESTING

A trio of tests shall be performed on the completely assembled valve prior to shipment. These shall include a hydrostatic test of up to two (2) times the working pressure (maximum 500 psi testing pressure), a tight seating test, and a performance test for simulated field conditions. The tests may be witnessed by the customer/engineer or representative.

PAINT

Ferrous surfaces of the valve shall be coated with NSF Certified Epoxy (Tnemec Series FC20) in accordance with ANSI/NSF Std. 61, and conforming to AWWA D102 Inside System No. 1.

Note: The Ross Valve Mfg. Co., Inc. reserves the right to modify valve construction which will result in equal or superior performance to existing designs. These modifications may be made at any time and at the sole discretion of the manufacturer.

Ross Valves last longer.

When George Ross founded our company in 1879, he made a product designed to last. He also created a company built on enduring values: integrity of design and engineering, quality of materials, craftsmanship in manufacturing, a high level of customer service, and flexible business systems that have evolved with technology and the times.

Now, much more than a century later, Ross automatic control valves are legendary throughout the world. Over the years, they have played a pivotal part in construction projects both large and small, serving systems as diverse in size and operating conditions as New York City, Los Angeles, Madrid, and Dubai.

Ross offers a complete line of standard valves including pump control, pressure reducing, flow control, altitude, back pressure sustaining, relief, surge control, electronic control valves, and float valves, as well as a complete line of strainers and diaphragm-style valves. Complementing these product lines are high energy dissipation anti-cavitation valves — our "WaterTamer." Rounding out our product line is a full line of valves for wastewater. Of course, we also have a variety of customized valves and valve features that can be engineered to suit any application, as well as pre-packaged valve vaults for turn-key installation.

Accurate. Ruggedly constructed. Versatile. Reliable. And backed by dedicated technical support and uncompromised field service. No wonder customers around the world always seem to say:

There's nothing like a Ross Valve.



Ross Valve Mfg. Co., Inc.
P.O. Box 595, Troy, NY 12181-0595, USA
Tel: 518-274-0961 • Fax: 518-274-0210
Email: sales@rossvalve.com • www.rossvalve.com



All Ross Valves meet or exceed all current AWWA standards for construction and pressure ratings.
WWV 06-10 5000



Ross Valves are known for their exceptional quality. And no wonder, because we control the process in-house from start to finish. After designing the components, molds are made. We then start with the finest raw materials. All metals are poured in our own New York based foundries. All parts are machined to specs. Then each valve is meticulously assembled, pilot valves and controls are set, and the valve is "wet" tested under the designed operating conditions. When you receive your new Ross Valve, you can count on its ability to perform from start to finish.

Buy American



All Ross Valves are 100% ARRA Compliant