

Multiple Applications



Water Management Solutions, Inc.

Going the extra mile starts here!™

Construction
Dewatering

Sewage Bypass

Flood Drainage

Mining/Quarries

Municipal

General Industrial



PrimeRite™ CT006 6" x 6" Automatic Dry Priming Pump



As an MWI Pump Partner, we are proud to offer the PrimeRite™ CT006. It is a perfect choice for contractors, mining operators, and general industrial or municipal use.

The main features of the PrimeRite are the oil-filled bearing box and mechanical seal in an oil bath that enables the pump to run dry all day long, making it the right choice for jobs that has inconsistent flows, like in sewage bypass pumping and job site dewatering. Our MWI Pumps are self-

contained on trailers with integral lifting bail, tie downs, and fuel tank. All pumps have been designed for the toughest applications and are maintained by our trained technicians. Let us help you make your next project a success!

Features

- Primes and reprimers automatically
- Belt driven compressor is water cooled and oil lubricated
- Vacuum & discharge pressure gauge
- Lockable fuel cap
- Integral 78 gallon fuel tank with gauge
- Hydraulic surge brakes
- 6" ANSI Pattern Flanges-suction and discharge
- Front and rear stabilizing jacks
- Trailer mounted (skid optional)
- DOT light kit
- 3" Lunette ring for Pintle Hitch
- Heavy-duty truck tie downs
- Lifting ball
- Optional float-activated, Auto Start/Stop control
- Solids handling to 3"

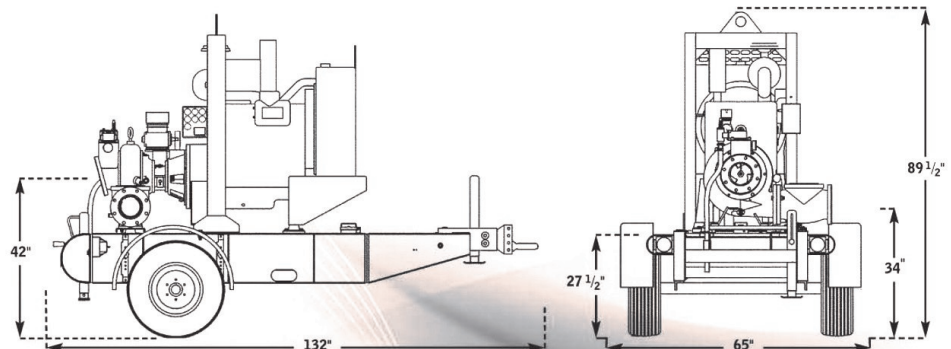

Contact Us!

434-664-8845

mark@watermngt.com

wendy@watermngt.com

www.watermngt.com