

DELTA

Bullnose Module Order Form

Office: 281-391-1320
 Fax: 281-391-2015
 Toll Free: 800-430-2226
 DRIsales@deltarefractories.com

Please circle appropriate fold style, then fill in dimensions

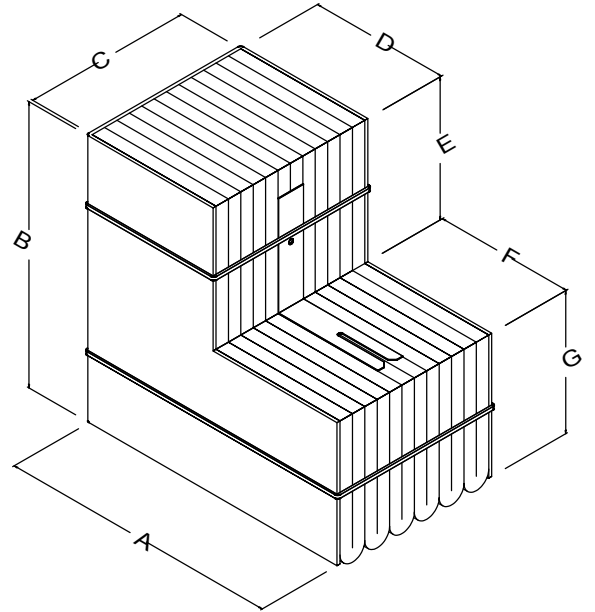
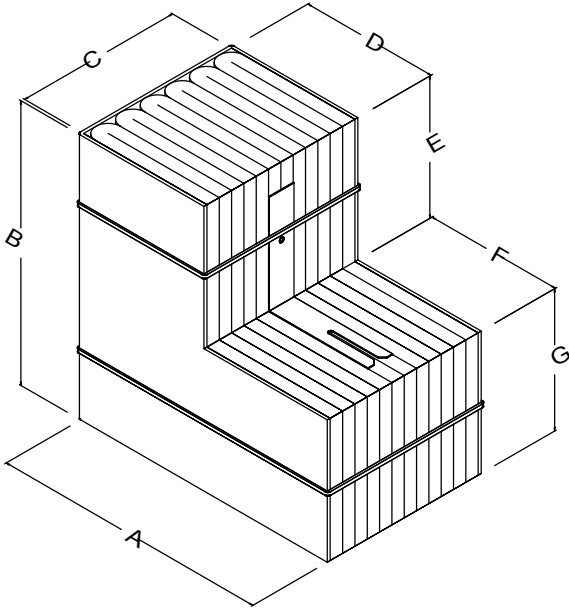

Dimensions

(Please complete)

A _____	E _____
B _____	F _____
C _____	G _____
D _____	

Module Density

(Please check)

- 8 PCF - 12" W uses 16 layers of 1" 6 lb. blanket
- 10.7 PCF - 12" W uses 16 layers of 1" 8 lb. blanket

(PCF = Pounds Per Cubic Foot)

Fiber Grade

(Please check)

- 2300° F
- 2600° F
- 2700° F (Special order)
- Other _____

Attachment Method

(Please check)

- Through Bolt Assembly - 304 SS
- Stud/Nut Assembly for Stud Welding* - 304 SS
- Stud/Nut Assembly - 304 SS - Welded to Plate*
(Carbon steel)
- Other _____

* Guide rod required for installation
 Other grades of steel available upon special request

This drawing and all information is the property of Delta Refractories, Inc.
 It is confidential and given to you for a limited purpose. Neither this drawing
 nor any part of this document may be copied, exhibited, or furnished to others
 without the consent of Delta Refractories, Inc.

Attachment Method for Delta DF Module

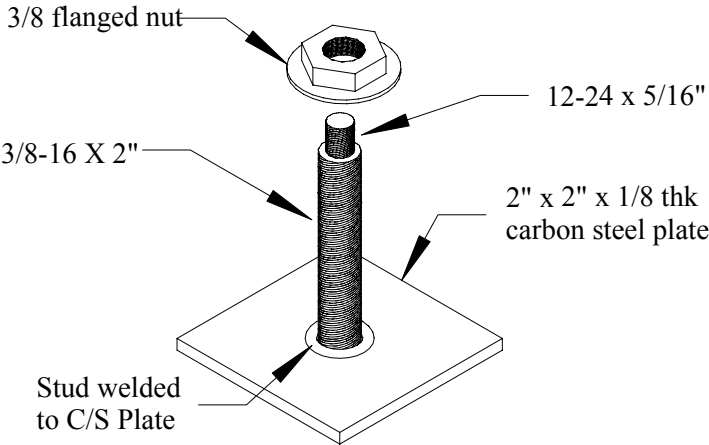
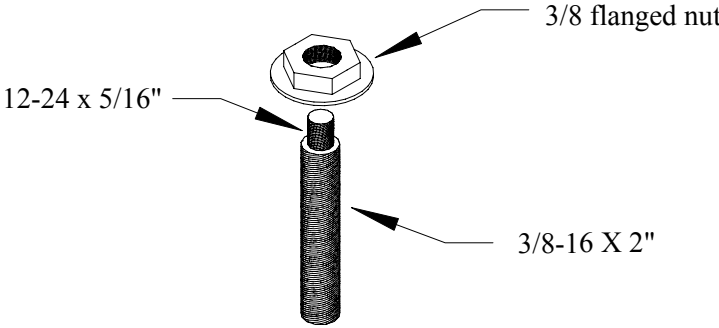
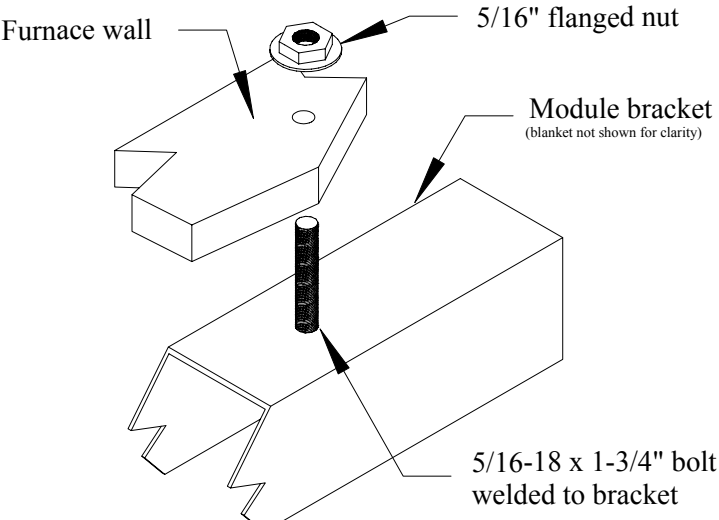
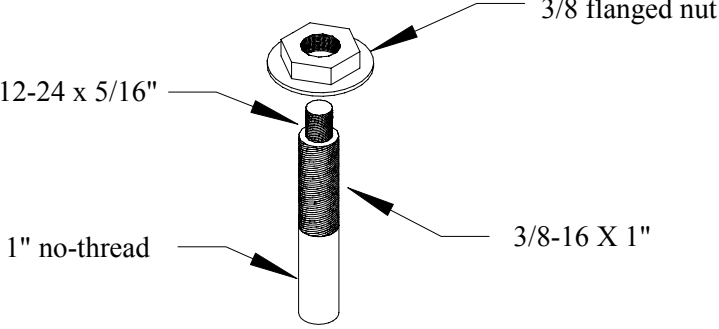
Stud/Nut/Plate Assembly	Stud/Nut Assembly
 <p>3/8 flanged nut</p> <p>12-24 x 5/16"</p> <p>3/8-16 X 2"</p> <p>2" x 2" x 1/8 thk carbon steel plate</p> <p>Stud welded to C/S Plate</p>	 <p>3/8 flanged nut</p> <p>12-24 x 5/16"</p> <p>3/8-16 X 2"</p> <p>3/8-16 x 2-3/8" BW - OAL 12-24 x 5/16" Ext. - 304 stainless steel Flanged Nut - 3/8" diameter - 304 stainless steel</p>
<p>3/8-16 x 2-3/8" BW - OAL 12-24 x 5/16" Ext. - 304 stainless steel welded to carbon steel plate Flanged Nut - 3/8" diameter - 304 stainless steel</p> <p>Guide rod required for installation</p>	<p>Guide rod required for installation</p>
 <p>Furnace wall</p> <p>5/16" flanged nut</p> <p>Module bracket (blanket not shown for clarity)</p> <p>5/16-18 x 1-3/4" bolt welded to bracket</p>	<p>Same as above but non threaded 1"</p>  <p>3/8 flanged nut</p> <p>12-24 x 5/16"</p> <p>1" no-thread</p> <p>3/8-16 X 1"</p> <h3>Through-Bolt Assembly</h3> <p>5/16-18 x 1-3/4" 304 stainless steel bolt welded to bracket between fiber & channel Flanged Nut - 5/16" diameter - 304 stainless steel</p>

This drawing and all information is the property of Delta Refractories, Inc. It is confidential and given to you for a limited purpose. Neither this drawing nor any part of this document may be copied, exhibited, or furnished to others without the consent of Delta Refractories, Inc.