



LaserControl NT-H 3D



Tool Measurement



NT Technology



NT-H 3D Technology



shark360 Technology



Tool Breakage Detection



Tool Length Measurement



Tool Radius Measurement



Tool Form Measurement



Tool Form Monitoring



Single Cutting Edge Monitoring



RunoutControl



ToolTipControl



MicroWearControl



Axes Compensation

LaserControl NT-H 3D

BLUM
focus on productivity



LaserControl NT-H 3D | Combined tool setting system for mill-turn machines

Multitasking for turn-mill machines – combines the benefits of two measuring technologies in one compact system

- Non-contact measurement of rotating tools with laser
- Tactile measurement of non-rotating tools
- Pre-aligned laser and touch probe for easy mounting
- Economic – one system for both turning and milling tools

Your benefit:

- Increased productivity and production quality
- No subsequent damage due to tool breakage
- Reduced set-up time and unmanned operation
- Reduced scrap rate

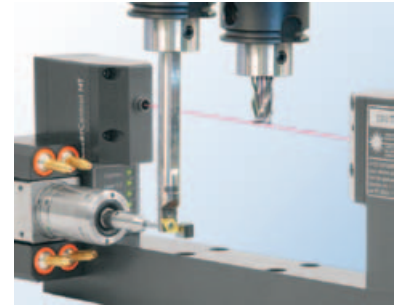
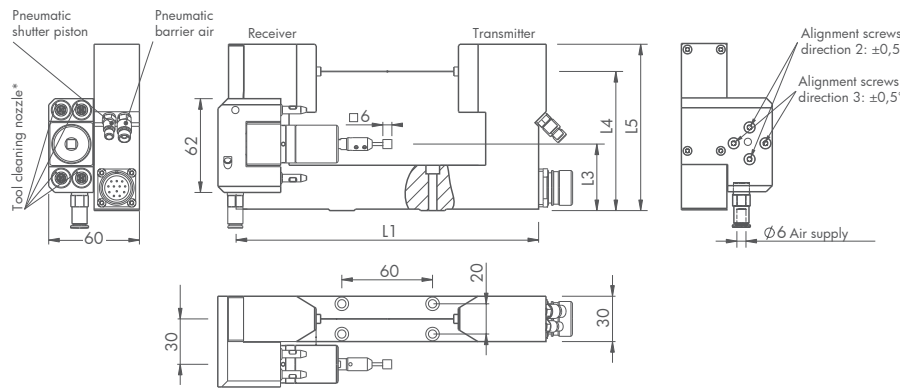

All tools with one system



Extremely fast measurement of non-rotating tools



Customary laser system

Technical data (LaserControl)

Laser safety classification	Class 2 acc. to IEC60825-1, 21 CFR 1040.10
laser type	Visible red light laser 630 - 700 nm <1 mW
Protection class	IP68
Power supply	24V DC / 160 mA
Inputs/Outputs	24V DC 0 - 5V DC analogue output *
Repeatability	Δ transmitter / receiver <30 mm: 0,1 μm 2σ **
Storage/Operating temperature	-10 °C ... +70 °C +5 °C ... +45 °C

Technical data (Touch Probe TC76)

Protection class	IP68
Measuring force in XY Z	1,3 N / 0,7 N *** 5,9 N
Max. deflection XY Z	± 15° 5 mm
Repeatability	0,4 μm 2σ

* Option ** Depending on installation situation, stability of fixation, distance and measuring mode *** Stylus L= 30 mm / 75 mm



Perfect solution – software for touch probe and laser system available



Blum worldwide Service & Support

More than 40 subsidiaries and service offices.

www.blum-novotest.com

Blum-Novotest Ltd.

33 Townfields
Lichfield, Staffordshire
WS13 8AA, United Kingdom

Phone: +44 1543 257111
Fax: +44 1543 251746
E-Mail: info@blum-novotest.co.uk

Blum LMT, Inc.

4144 Olympic Boulevard
Erlanger, KY 41018
USA

Phone: +1 (859) 344 6789
Fax: +1 (859) 344 6799
E-Mail: solutions@blumlmt.com