



c-vision™ Benchtop

Benchtop Video Contour Projector®



c-vision is the ultimate shop floor video measuring system. Its rugged design and 60 lb load capacity put advanced automatic video measurement capability to work right where you need it.

- Telecentric dual magnification optical system with advanced digital imaging technology
- Shop hardened and convenient for use on a benchtop
- vCAD™ Virtual Chart Gage software - directly compare parts to CAD
- Motorized XY table motion with precision linear scales and manual fine adjusters
- Optional fully automatic Measure-X® 2D measuring software



Metrology Software:

- vCAD™ virtual chart gage software
- Optional: Measure-X® 2D metrology software, MeasureFit®, SmartReport®, SmartTree™, CAD import option for Measure-X 2D, Measure-X 2D offline

Available Options and Accessories:

- Extended X-axis travel
- Dual monitor user interface
- Bar code reader
- Universal fixture kit
- Rotary indexer
- Overhead light shield
- Calibration standards
- Heavy duty steel weldment stand
- Ergonomic, motorized adjustable height stand
- Swing away lamphouse
- Worktable dust cover
- Service and support contracts

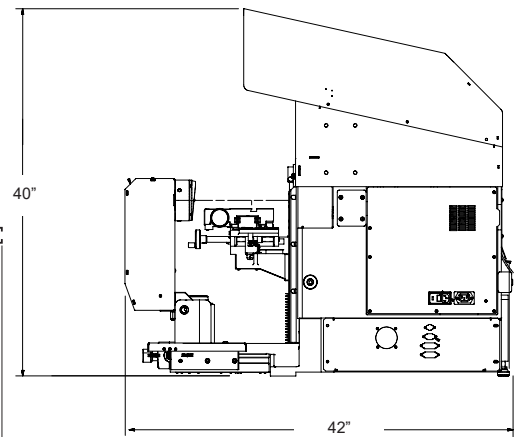
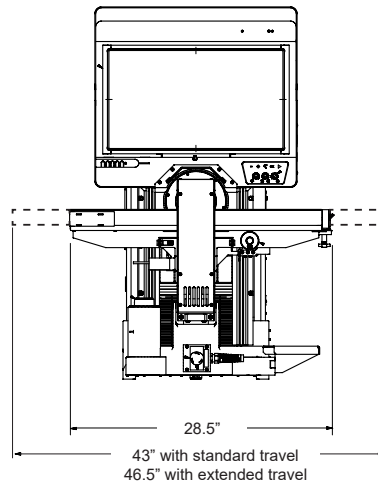

Uncrated: 530 lb
Crated: 650 lb

	Standard	Optional
XYZ Travel Range (in)	15 x 6 x 2	18 x 6 x 2
Helix Angle Range	±7.5° with pivoting worktable assembly and zero stop	
Throat Clearance (in)	10	
XY Scale Resolution (in)	0.00004	0.00002
XY Drive System	Motorized with variable speed joystick control	
Worktable	Hardcoat anodized aluminum with dovetail slot	
Recommended Maximum Load Capacity (lb)	60	
Optics	Dual magnification, fully telecentric, long depth of field	
FOV Size (in)	Low Mag: 3 High Mag: 0.75	
Depth of Field (in)	Low Mag: 1.5 High Mag: 0.2	
Working Distance (in)	4	
Illumination	Green LED profile light and green LED oblique ring illuminator with eight selectable patterns	Green LED through-the-lens surface light with continuously variable intensity control
Camera	QVI® High Density Megapixel Metrology Camera	
Image Processing	256 level grayscale processing with 10:1 subpixel resolution	
System Controller	QVI standard system controller with networking and communication ports*	
	*Controller configuration subject to change without notice.	
Power Requirements	100-120 VAC or 200-240 VAC, 50/60 Hz, 1 phase, 600W	
Rated Environment	18°- 22° C, stable at ± 1° C; 30%-80% humidity; vibration <0.001g below 15 Hz	
Operating Environment, Safe	15° - 30° C	
Stage Accuracy (E₂)¹	(7.5 + L/100) μm	
Field of View Accuracy²	Low Mag: 7.5 μm High Mag: 4.0 μm	

¹Where L = measuring length in mm. Applies to the smallest field size at each optical magnification. XY axis artifact: QVI calibration reticle P/N 640298 or 640271.
²Applies to the smallest field size at each optical magnification. QVI calibration artifact P/N 640133 or 640271 for low magnification; QVI calibration artifact P/N 640567-1 for high magnification. Calibration artifacts must be positioned in the standard measuring plane, defined as perpendicular to the optical axis within 0.5 mm, and within 5.0 mm of best focus. Weight not to exceed 5 kg equally distributed on the worktable. Applies to a thermally stable system calibrated and operated within the rated environment.



Quality Vision International, Inc.

Phone: +1 585 758 1300

Fax: +1 585 506 4307

ccpinfo@qvii.com

www.qvii.com/ccp

