

Student's

First Reading Book

Teach Your Child To Read With Fun & Easy Lessons!



5-MINUTE LESSONS

SIGNATURE PAGE DESIGN

NO COLOR-AVOIDS DISTRACTION



Student's

First Reading Book

Fun, Easy, Inexpensive, and Systematic!

Copyright © 2012, 2016, 2017, 2020 by N. J. DeCandia, BSME, CPA, BBA; Rita D. Newman, BS Early Childhood Education, and its licensors. All rights reserved.

ISBN-10: 1475219784

ISBN-13: 978-1475219784

Authors' biographies: Nick has a BSME from the University of Notre Dame. He's a CPA, with a second Bachelor's degree in Finance/Accounting - from the University of New Mexico. Nick became a nationally published author back in 2001, with "The New Face of the IRS" published in the January 2001 issue of Strategic Finance magazine.

Rita D. Newman has a Bachelor's of Science degree in Early Childhood Education, taught Kindergarten for a few years, and directed a very successful preschool for 23 years.

Printed in the United States of America. 1 2 3 4 ACS 12 16 17 20

One month into Kindergarten, Nick's daughter [Rita's granddaughter] came to him and said, "I want to learn to read!" After a couple of purchases, he was surprised how little one book had in it, and how difficult another was making it. So, he asked a friend of his [a former Pre-School Director] - whose son was reading on a 2nd Grade level - the year before in his daughter's preschool class, how she taught her son to read. She said, "With 3-letter words!" Nick and his daughter also had a letter-sound tape in the car, at that time. Well, by the powers that be, it dawned on him that if his daughter knew three letter-sounds, she'd likely be able to read a three letter word. So, he started putting pages together, and it worked like a charm. "My Child's First Reading Book" was born and, it really was my child's first reading book! -N.J. DeCandia, Author & Founder, Den Publishing Company.

Dedication: this book is dedicated to Nick's daughter (Rita's granddaughter), with acknowledgment and thanks to the following early childhood education professionals: Swarupa Watlington, Wendy George, Cindy Rossner, Dale Dickey & Sue Lamier.

Disclaimer: this book is not a substitute for adult supervision, nor do we guarantee results.

Den's Evolution of Content and Titles: as mentioned above, the original title was "My Child's First Reading Book" (MCFRB) - because it really was my child's first reading book. However, my mom - contributing author Rita - saw that it worked for more than just her granddaughter, when she started selling it at her preschool. So, she suggested a title change. That's when "First Reading Book" (FRB) aka "Student's First Reading Book" took hold. After some time, we realized we could give students more help on the reading pages, by hyphenating the 3-letter words in addition to the whole word. That's when "The Phonics Reading Book" (TPRB) was born. Note: we still maintain MCFRB and FRB as "whole language" reading pages. Finally, when Nick started working with his church's pre-Kindergarten program, he decided to develop instruction to include the alphabet, which is a pre-requisite of MCFRB, FRB & TPRB. Hence, "The Alphabet Book" (TAB) was born! Note: TAB includes "pre-phonics" lessons (aka: phonemic or sound awareness lessons).

Den Publishing Company
www.DenPublishing.com
Orlando, Florida



"Quick Start" Instructions

1) Alphabet Knowledge - Does your student know the alphabet?
If not => flash cards, first (Appendix A or *The Alphabet Book*).



2) Sit With 'Em - ~5 minutes a day, 4 days per week.
Just a little of your time can make a world of progress!

3) Don't Skip Around - The lessons are short,
but are in a very specific order.

4) Reading Pages (bat, cat..) - Point & demonstrate individual
& combined sounds (b-a-t; bat). Have student do the same.

5) Review Pages - Don't skip these. With rhyming and page design,
this is where putting those sounds together really starts to jell!

6) Review - start each new day with a brief review, and if you
feel they're up to it, cover the picture on a Reading page(s).

7) Keep It Fun - "high fives" for progress made, and use coloring pages
to balance learning with fun!

Notes: (1) ample review is going to be needed, as learning to read is a kin to us adults learning a new language; and getting over the newness of each letter having a sound & how to put those sounds together - may not happen the very first time through Chapter 1. Remember: any progress is our friend. Discouragement is the enemy; (2) don't be alarmed if your child doesn't know one or more of the words / pictures. This will be part of the learning experience, as well!

**"The National Reading Panel's analysis made it clear that
the best approach to reading instruction is one that incorporates:
*Explicit instruction in phonemic [sound] awareness
*Systematic phonics instruction.."**



National Reading Panel. National Institutes of Health. National Institute of Child Health and Human Development. <http://www.nichd.nih.gov/research/supported/Pages/nrp.aspx>.

The National Reading Panel was tasked by Congress in 1997 to determine how children learn best to read. The panel reviewed thousands upon thousands of studies (all available research on teaching reading). The spent over two years analyzing - including holding open panel discussions.

Learning To Read = 2 Steps

1) Learning The Letter Sounds

2) Putting Those Sounds Together

Section 1 - Short Vowel Book Skills Teaches All the Letter Sounds (Except /q/)

By The End Of Section 1, They Have the Tools to Read Short-Vowel Books.

Section 2 Teaches Them Long Vowels, Blends & Segmenting of Big Words

By The End Of Section 2, They Have the Tools to Read Any Beginning Book!

Signature Page Design

White on the outskirts helps focus attention - to the center of the page and the task at hand.

Large pictures and letters for the student.

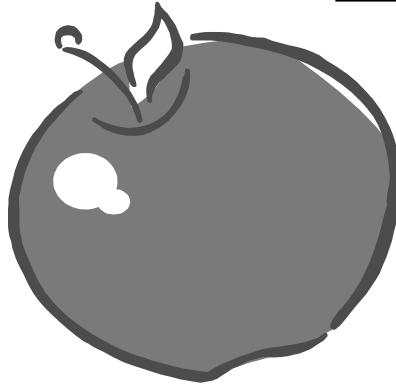

Grayscale keeps interest level high, and provides coloring page.

a

Smaller prompt for the parent.

Parent prompt (suggested) - point and say,
"Apple starts with /a/ and sounds like "ah",
"apple - a - ah." Have your child repeat it - pointing.
Head for the coloring page, for both fun and to reinforce the lesson !

Table of Contents

Quick Start Instructions	3	
SECTION 1: SHORT-VOWEL BOOK SKILLS		
<u>Chapter 1 - Short Vowel /a/</u>		
a - letter-sound	9	Lesson 1
b - letter-sound	11	Lesson 2
t - letter-sound	13	Lesson 3
b, a, t, /b-a-t/ review & reading page	15	Lesson 4
/b-a-t/, "bat" reading page	17	Lesson 5
c - letter-sound	19	Lesson 6
/c-a-t/, "cat" reading page	21	Lesson 7
h - letter-sound	23	Lesson 8
c, /c-a-t/, h, /h-a-t/ review & reading page	25	Lesson 9
/h-a-t/, "hat" reading page	27	Lesson 10
s - letter-sound	29	Lesson 11
/s-a-t/, "sat" reading page	31	Lesson 12
m - letter-sound	33	Lesson 13
/m-a-t/, "mat" reading page	35	Lesson 14
s, /s-a-t/, m, /m-a-t/ review & reading page	37	Lesson 15
short vowel /a/, review / assessment page	39	Lesson 16
<u>Chapter 2 - Short Vowel /e/</u>		
e - letter-sound	41	Lesson 17
p - letter-sound	43	Lesson 18
n - letter-sound	45	Lesson 19
p, e, n, /p-e-n/ review & reading page	47	Lesson 20
/p-e-n/, "pen" reading page	49	Lesson 21
/t-e-n/, "ten" reading page	51	Lesson 22
/m-e-n/, "men" reading page	53	Lesson 23
/h-e-n/, "hen" reading page	55	Lesson 24
/m-e-n/, /t-e-n/, /h-e-n/ reading review page	57	Lesson 25
short vowel /e/, review / assessment page	59	Lesson 26
<u>Chapter 3 - Short Vowel /i/</u>		
i - letter-sound	61	Lesson 27
/i-n/, "in" reading page	63	Lesson 28
/p-i-n/, "pin" reading page	65	Lesson 29
i, /i-n/, /p-i-n/ review & reading page	67	Lesson 30
w - letter-sound	69	Lesson 31
/w-i-n/, "win" reading page	71	Lesson 32
/b-i-n/, "bin" reading page	73	Lesson 33
w, /w-i-n/, /b-i-n/ review & reading page	75	Lesson 34
short vowel /i/, review / assessment page	77	Lesson 35
<u>Chapter 4 - Short Vowel /o/</u>		
o - letter-sound	79	Lesson 36
/o-n/, "on" reading page	81	Lesson 37
/m-o-m/, "mom" reading page	83	Lesson 38
o, /o-n/, /m-o-m/ review & reading page	85	Lesson 39
/h-o-p/, "hop" reading page	87	Lesson 40
/m-o-p/, "mop" reading page	89	Lesson 41
/p-o-p/, "pop" reading page	91	Lesson 42

Table of Contents (continued)

SECTION 1: SHORT-VOWEL BOOK SKILLS (cont.)

/h-o-p/, /m-o-p/, /p-o-p/ reading review page	93	Lesson 43
short vowel /o/, review / assessment page	95	Lesson 44
<u>Chapter 5 - Short Vowel /u/</u>		
u - letter-sound	97	Lesson 45
/u-p/, "up" reading page	99	Lesson 46
/c-u-p/, "cup" reading page	101	Lesson 47
u, /u-p/, /c-u-p/ review & reading page	103	Lesson 48
/p-u-p/, "pup" reading page	105	Lesson 49
g - letter-sound	107	Lesson 50
/g-u-m/, "gum" reading page	109	Lesson 51
/p-u-p/, g, /g-u-m/ reading & review page	111	Lesson 52
short vowel /u/, review / assessment page	113	Lesson 53
<u>Chapter 6 - More Consonants</u>		
x - letter-sound	115	Lesson 54
/a-x/, "ax" reading page	117	Lesson 55
phrase reading page ("sit on mat")	119	Lesson 56
phrase reading page ("pin hat on mom")	121	Lesson 57
/o-x/, "ox" reading page	123	Lesson 58
x, /a-x/, /o-x/ review & reading page	125	Lesson 59
d - letter-sound	127	Lesson 60
/d-a-d/, "dad" reading page	129	Lesson 61
f - letter-sound	131	Lesson 62
d, /d-a-d/, f review & reading page	133	Lesson 63
/f-a-n/, "fan" reading page	135	Lesson 64
v - letter-sound	137	Lesson 65
/v-a-n/, "van" reading page	139	Lesson 66
/f-a-n/, v, /v-a-n/ reading & review page	141	Lesson 67
chapter 6, review / assessment page	143	Lesson 68
<u>Chapter 7 - Last of the Consonants</u>		
j - letter-sound	145	Lesson 69
/j-e-t/, "jet" reading page	147	Lesson 70
k - letter-sound	149	Lesson 71
j, /j-e-t/, k review & reading page	151	Lesson 72
/k-i-t/, "kit" reading page	153	Lesson 73
r - letter-sound	155	Lesson 74
/r-u-n/, "run" reading page	157	Lesson 75
/k-i-t/, r, /r-u-n/ reading & review page	159	Lesson 76
l - letter-sound	161	Lesson 77
/l-i-d/, "lid" reading page	163	Lesson 78
y - letter-sound	165	Lesson 79
l, /l-i-d/, y review & reading page	167	Lesson 80
/y-e-s/, "yes" reading page	169	Lesson 81
z - letter-sound	171	Lesson 82
/z-i-p/, "zip" reading page	173	Lesson 83
/y-e-s/, z, /z-i-p/ reading & review page	175	Lesson 84
chapter 7, review / assessment page	177	Lesson 85
<i>Congratulations – You Can Read Short-Vowel Books!</i>	179	

SECTION 2: LONG VOWELS & BLENDS

<u>Chapter 1 - Long Vowels</u>	
Long Vowel /a/ Lesson	181
Long Vowel /i/ Lesson	183
Long Vowel /o/ Lesson	185
Long Vowel /u/ Lesson	187
<u>Chapter 2 - Consonant Blends (/st/, /nd/, /wh/, /ck/, /ll/)</u>	
/st/ Blend Lesson	189
/nd/ Blend Lesson	191
/wh/ Blend Lesson	193
/ck/ Blend Lesson	195
/ll/ Blend Lesson	197
<u>Chapter 3 - Consonant Blends (/sh/, /ch/, /th/, /ng/)</u>	
/sh/ Blend Lesson	199
/ch/ Blend Lesson	201
/th/ Blend Lesson	203
/ng/ Blend Lesson	205
<u>Chapter 4 - Vowel Blends (/oa/, /ee/, /ea/, /oo/)</u>	
/oa/ Vowel Team Lesson.....	207
/ee/ Vowel Team Lesson.....	209
/ea/ Vowel Team Lesson.....	211
/oo/ Vowel Team Lesson.....	213
<u>Chapter 5 - Mixed Blends (/oy/, ow/ou, /aw/)</u>	
/oy/ Blend Lesson	215
/ow/ Blend Lesson	217
/ou/ Blend Lesson	219
/aw/ Blend Lesson	221
<u>Chapter 6 - Mixed Blends (/ar/, /er/, /or/, /ew/)</u>	
/ar/ Blend Lesson	223
/er/ Blend Lesson	225
/or/ Blend Lesson	227
/ew/ Blend Lesson	229
<u>Chapter 7 - Other Blends (/ay/, soft-c, /qu/)</u>	
/ay/ Blend Lesson	231
soft-c Blend Lesson	233
/qu/ Blend Lesson	235
<u>Chapter 8 - Sight Words & Punctuation</u>	
"is" & "the" Sight Words Lesson	237
"of" & "you" Sight Words Lesson	239
"to" & "my" Sight Words Lesson	241
"are" & "do" Sight Words Lesson	243
"she" & "does" Sight Words Lesson	245
Punctuation Lesson	247
<u>Chapter 9 - Segmenting</u>	
"rab-bit" Segmenting Lesson.....	248
"ti-ger" Segmenting Lesson.....	250
"ze-bra" Segmenting Lesson.....	252
"sn-ake" Segmenting Lesson.....	254
"sh-ark" Segmenting Lesson.....	256
"sk-unk" Segmenting Lesson.....	258
"dra-gon" Segmenting Lesson.....	260

Table of Contents (continued)

Sentence reading page ("I see a tiger!")	262
Appendix A: Alphabet Flash Cards	263
Appendix B: Any Trouble Remembering Letter-Sounds?.....	271
Appendix C: List of All English Language Sounds	274
Index	275

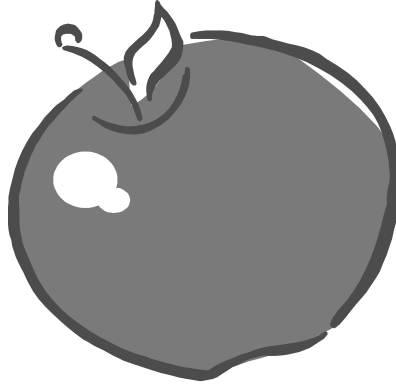

a

Parent prompt (suggested) - point and say,
"Apple starts with /a/ and sounds like "ah",
"apple - a - ah." Have your child repeat it - pointing.
Head for the coloring page, for both fun and to reinforce the lesson!

A

a

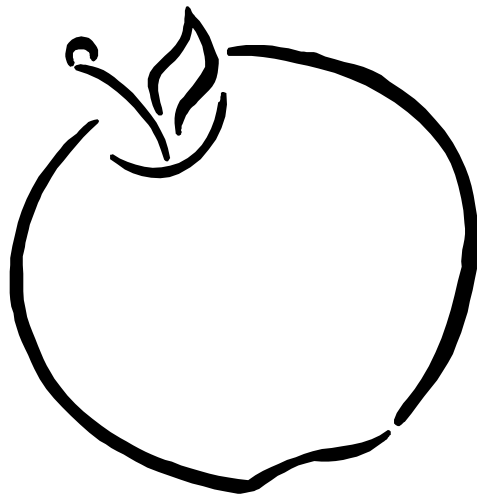



b

Parent prompt (suggested) - point and say,
"Balloon starts with /b/ and sounds like "buh",
"balloon - b - buh." Have your child repeat it - pointing.
Head for the coloring page, for both fun and to reinforce the lesson!

B b



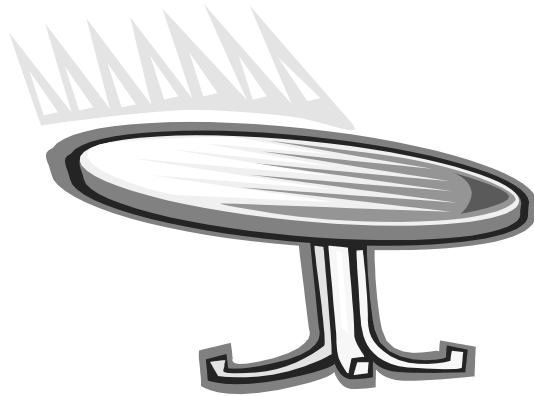

Parent prompt (suggested) - point and say,
"Table starts with /t/ and sounds like "tih",
"table - t - tih." Have your child repeat it - pointing.
Head for the coloring page, for both fun and to reinforce the lesson!

T +



b .



a .

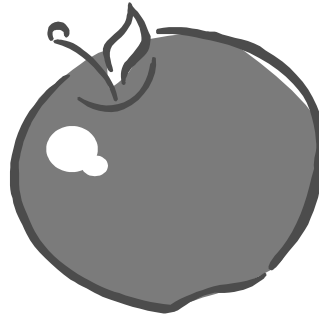

t .

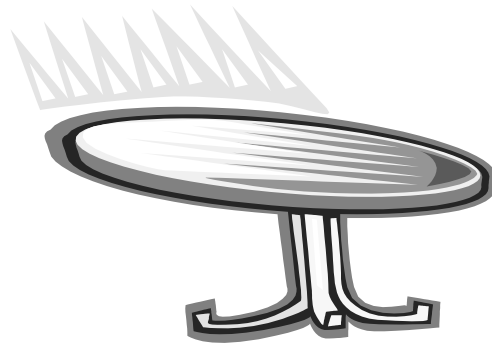

b a t

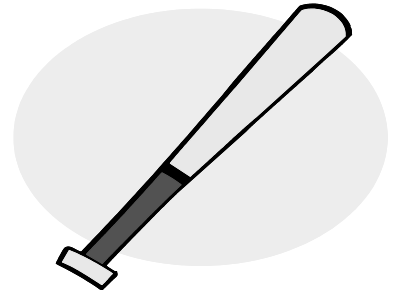

b -



a -

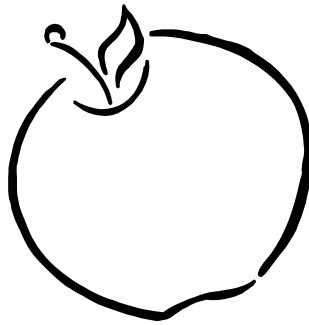

t -

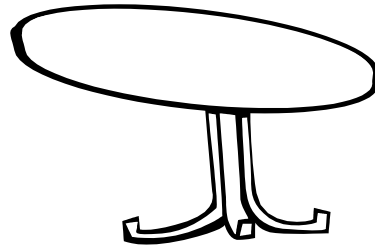

b a t

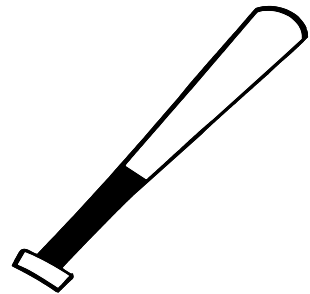

b a t

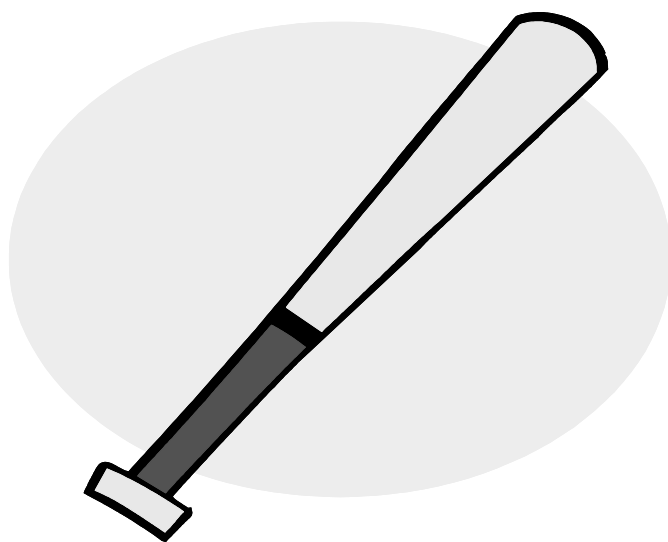

b a t

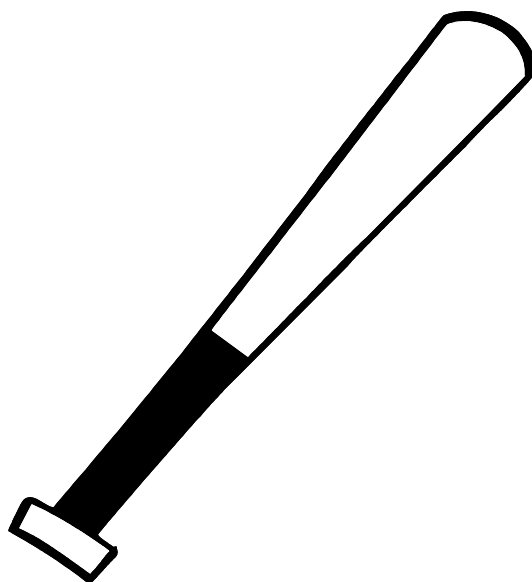

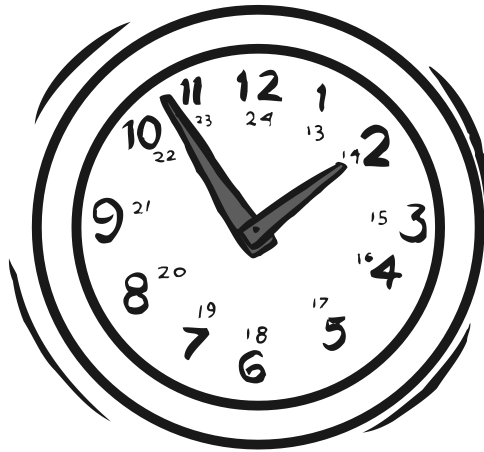

C

Parent prompt (suggested) - point and say,
"Clock starts with /c/ and sounds like "kuh",
"clock - c - kuh." Have your child repeat it - pointing.
Head for the coloring page, for both fun and to reinforce the lesson!

C C

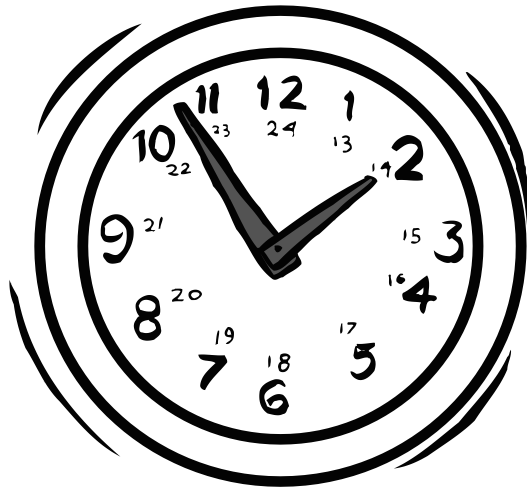

cat



c a t

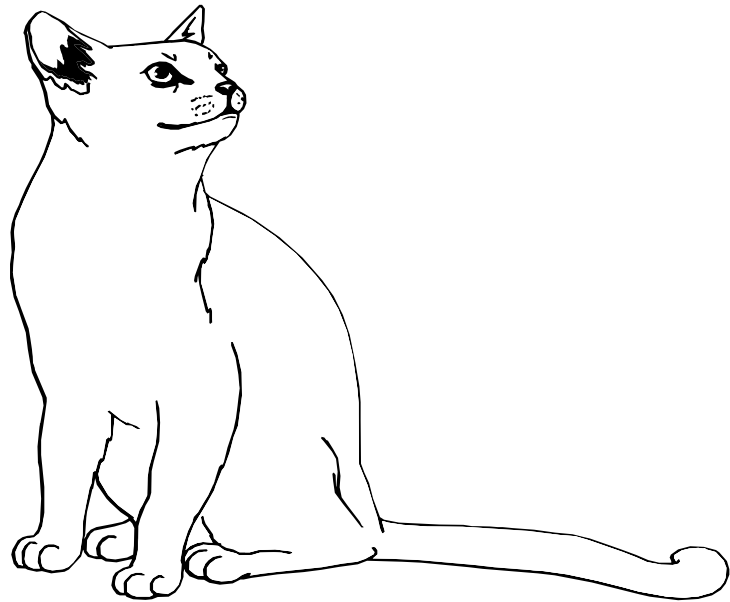



h

Parent prompt (suggested) - point and say,
**"House starts with /h/ and sounds like "huh",
"house - h - huh."** Have your child repeat it - pointing.
Head for the coloring page, for both fun and to reinforce the lesson!

H h



c -

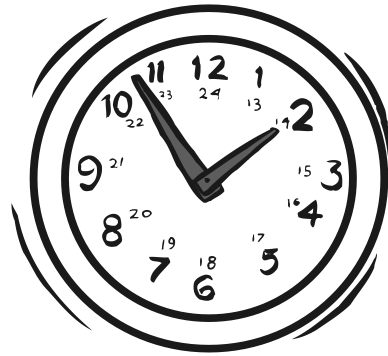

cat



h -



hat



c

-

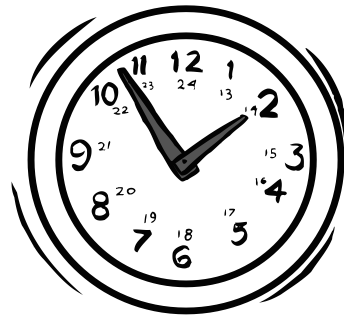

c

a

t

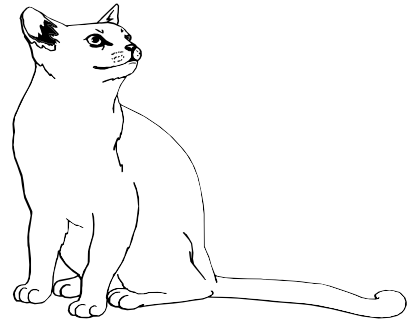

h

-



h

a

t

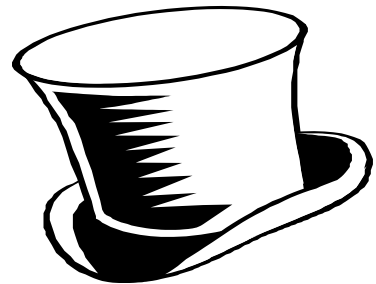

h a t



h a t

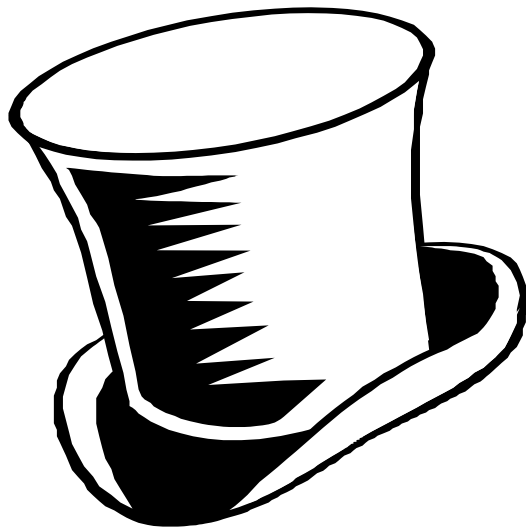

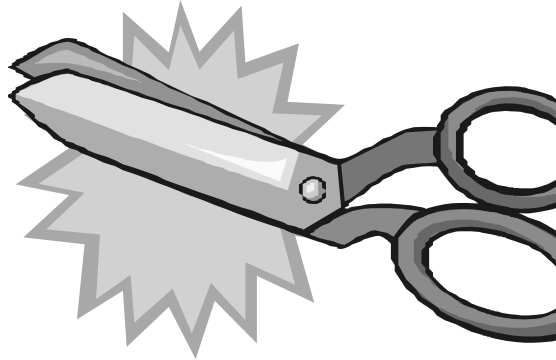

S

Parent prompt (suggested) - point and say,
"Scissors starts with /s/ and sounds like "sss",
"scissors - s - sss." Have your child repeat it - pointing.
Head for the coloring page, for both fun and to reinforce the lesson !

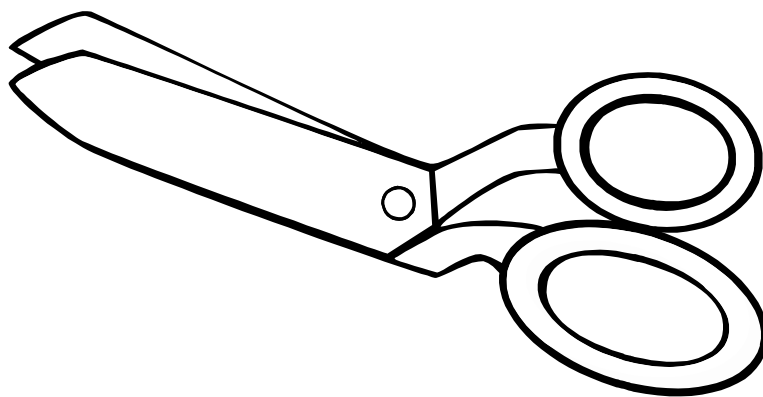
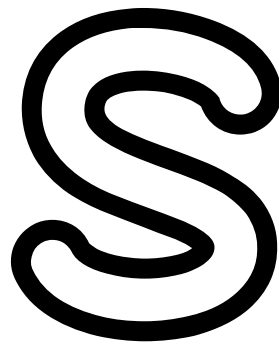
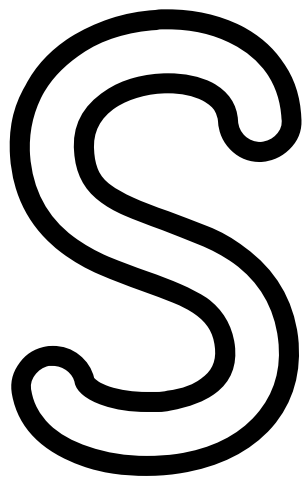

s a t



s a t



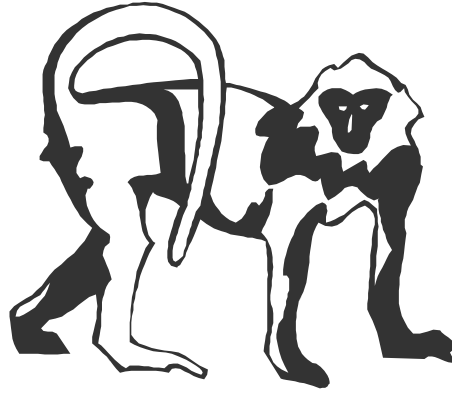

m

Parent prompt (suggested) - point and say,
**"Monkey starts with /m/ and sounds like "mm",
"monkey - m - mm."** Have your child repeat it - pointing.
Head for the coloring page, for both fun and to reinforce the lesson!

M m

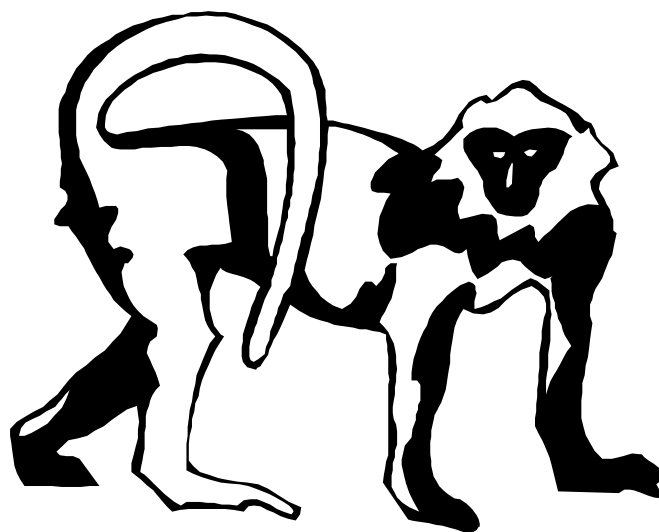

mat

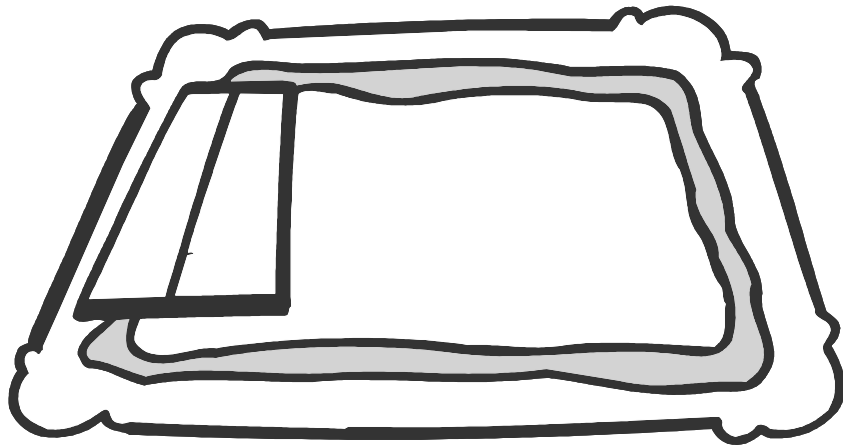

m a t

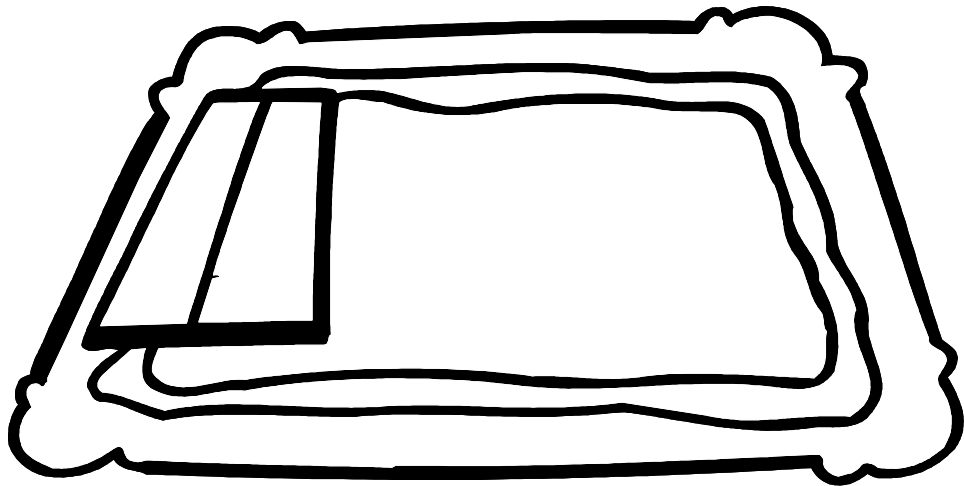

s -

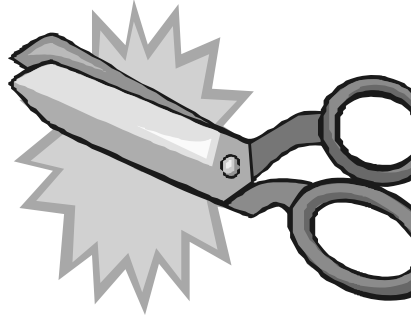

s a t



m -

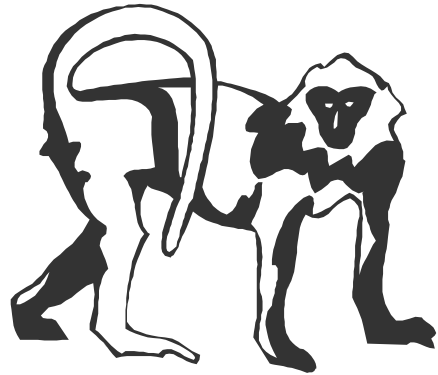

m a t

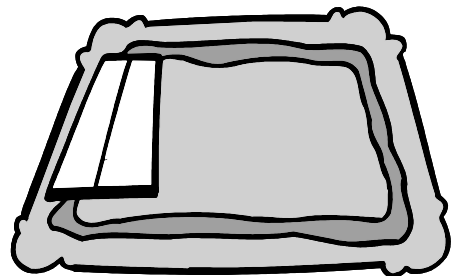

s

-

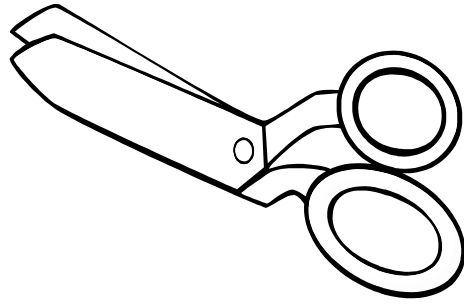

s

a

t



m

-

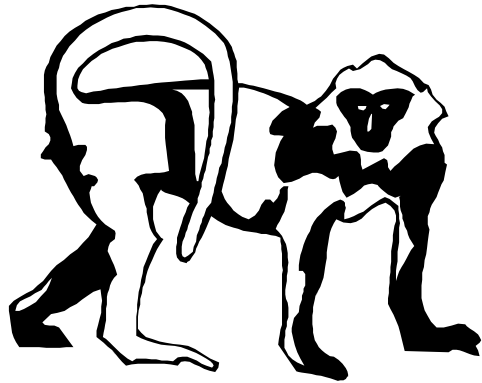

m

a

t

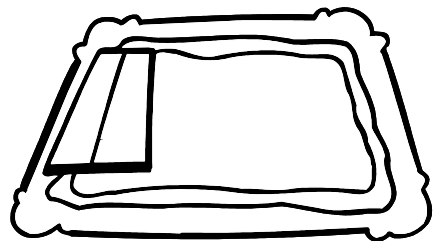

b a t

c a t

h a t

s a t

m a t

b a t

c a t

h a t

s a t

m a t

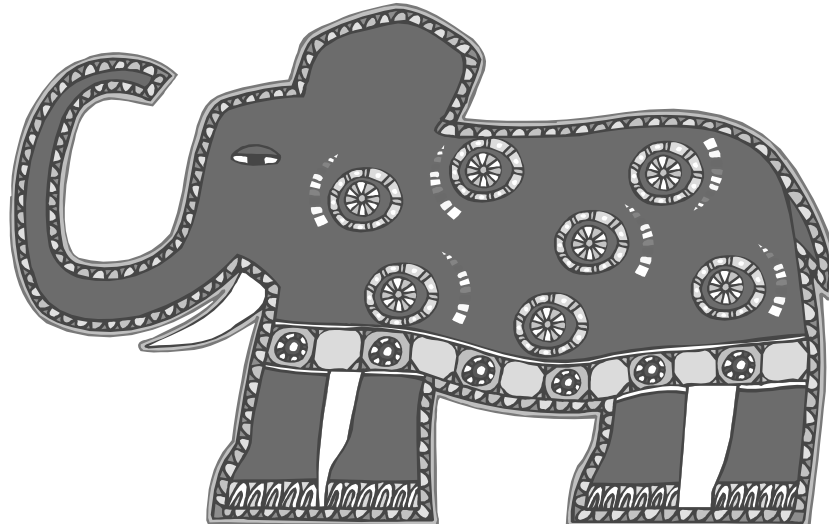

e

Parent prompt (suggested) - point and say,
**"Elephant starts with /e/ and sounds like "eh",
"elephant - e - eh."** Have your child repeat it - pointing.
Head for the coloring page, for both fun and to reinforce the lesson !

E e

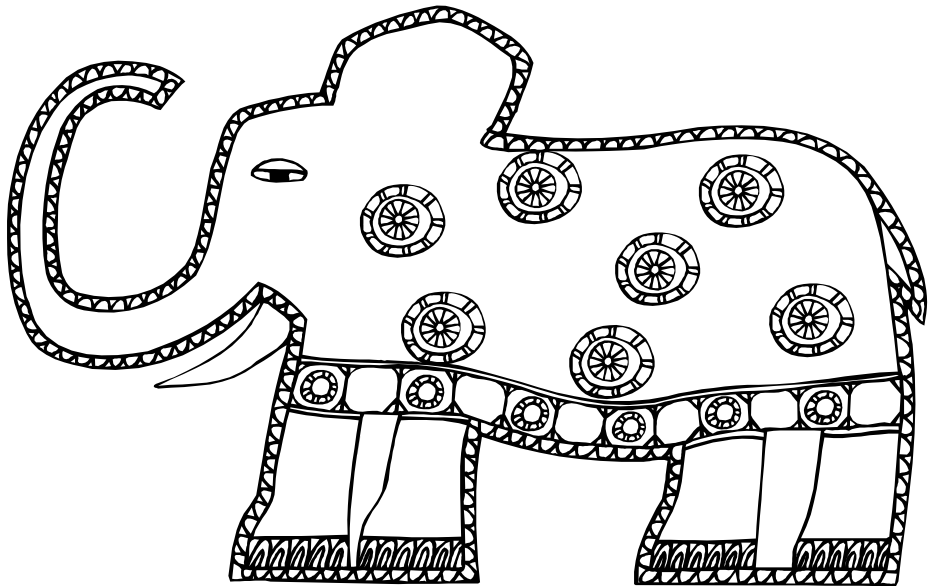

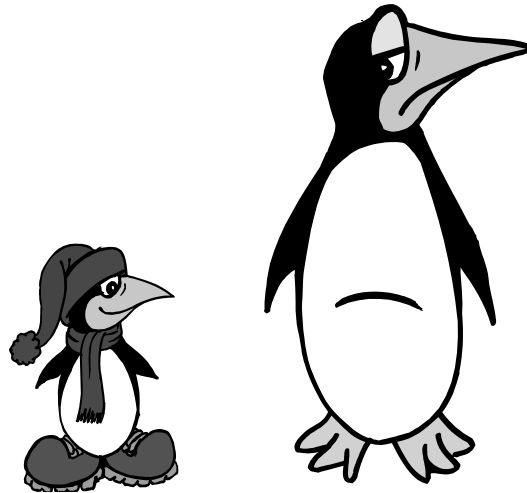

p

Parent prompt (suggested) - point and say,
***"Penguin starts with /p/ and sounds like "puh",
"penguin - p - puh."*** Have your child repeat it - pointing.
Head for the coloring page, for both fun and to reinforce the lesson!

P

p

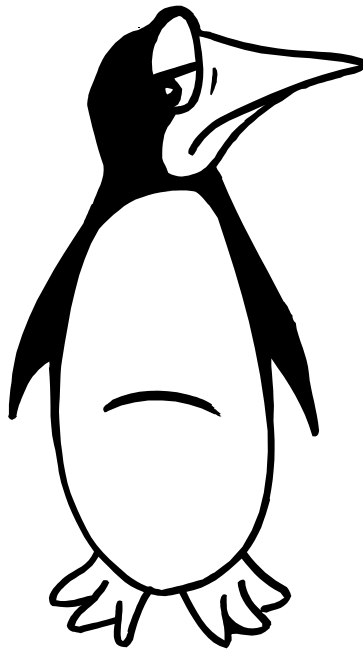
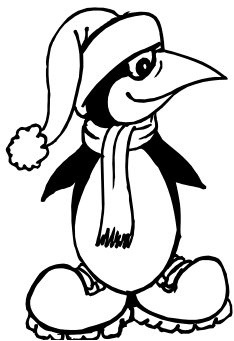

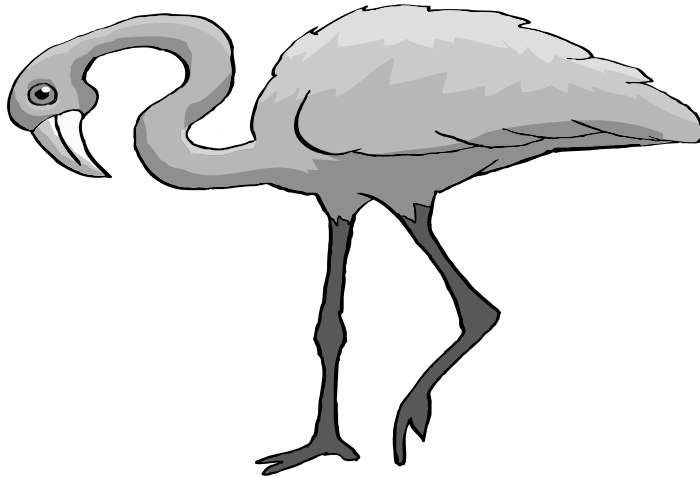

n

Parent prompt (suggested) - point and say,
"Neck starts with /n/ and sounds like "nn",
"neck - n - nn." Have your child repeat it - pointing.
Head for the coloring page, for both fun and to reinforce the lesson!

N n

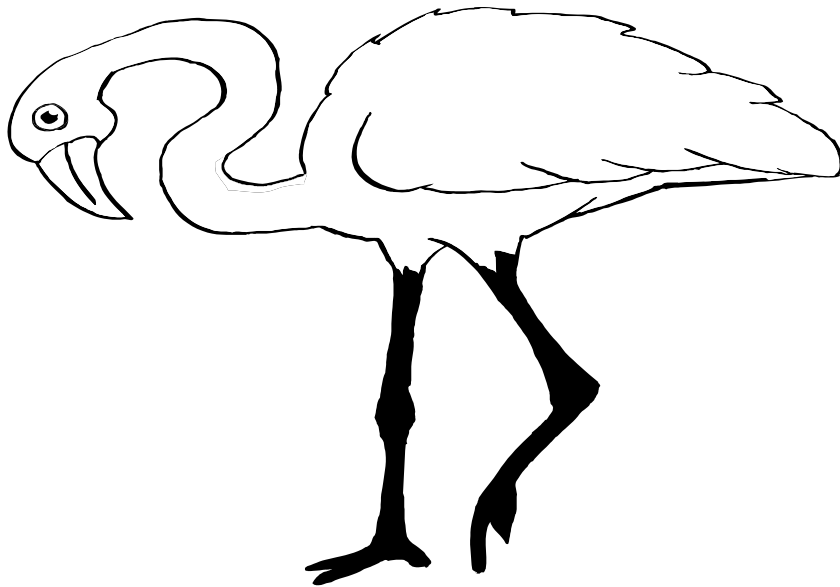

p .

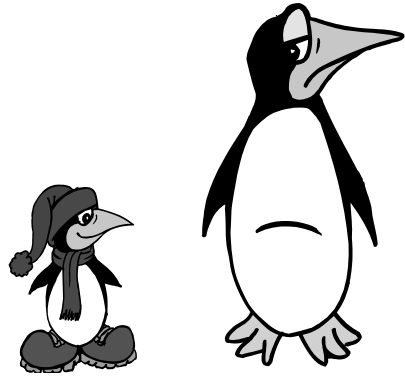

e .

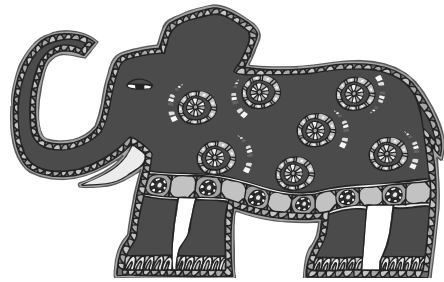

n .

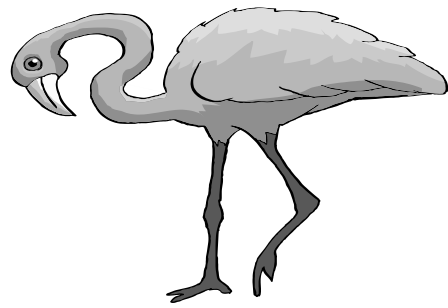

pen



p -

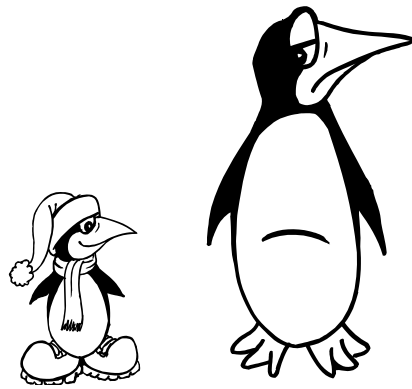

e -

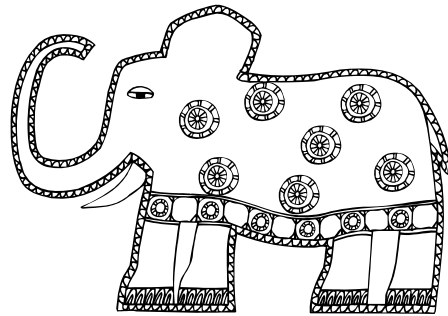

n -

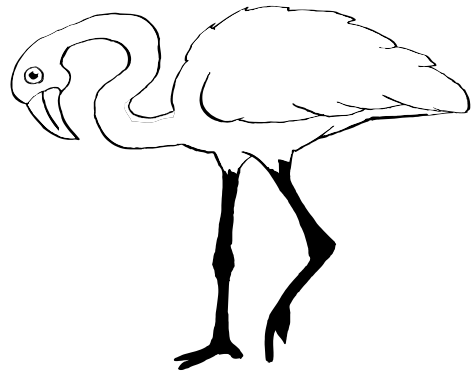

pen

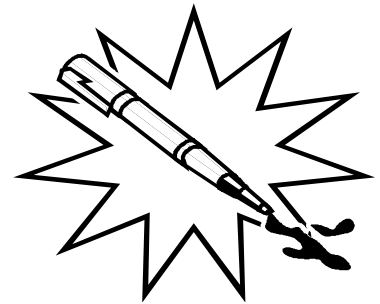

pen



p e n

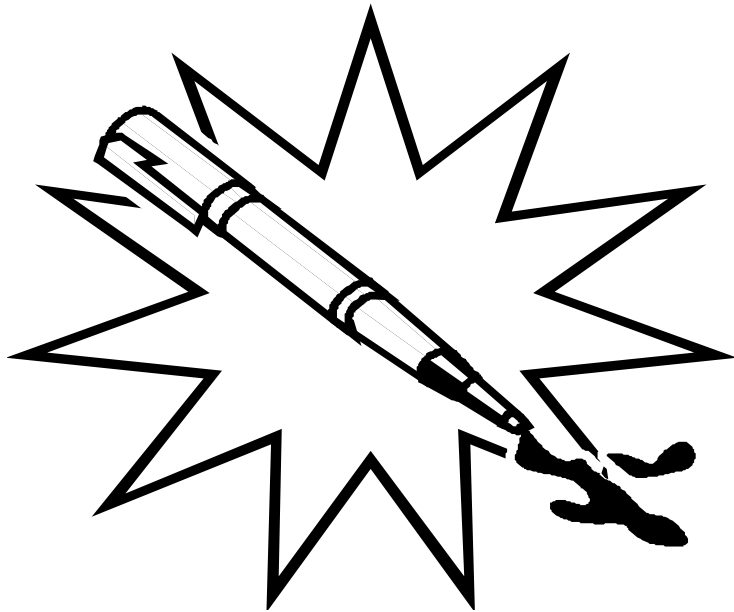

t e n

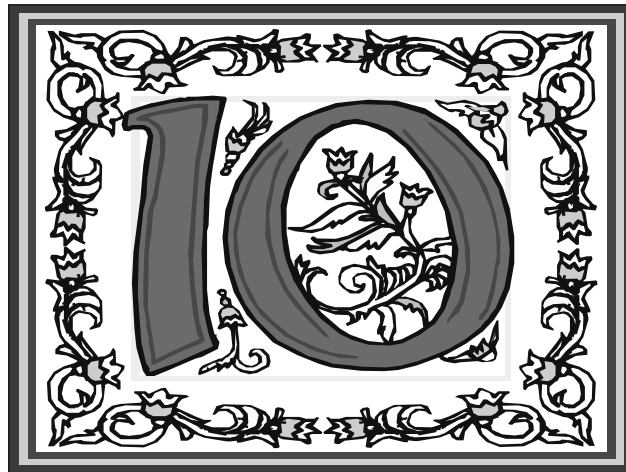

t e n

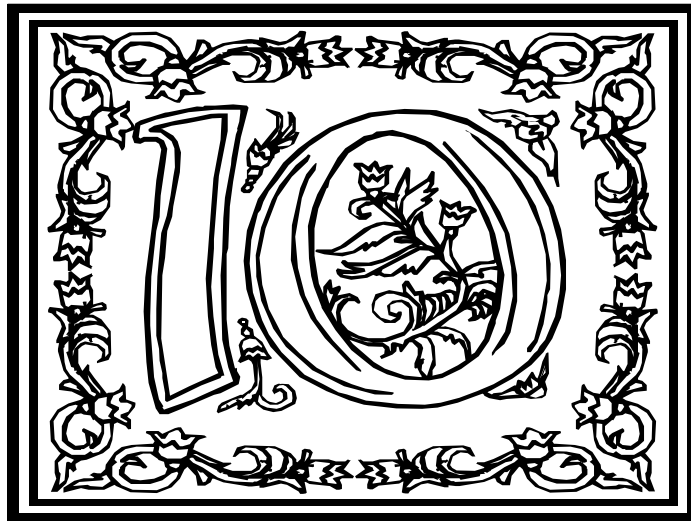

men



m e n

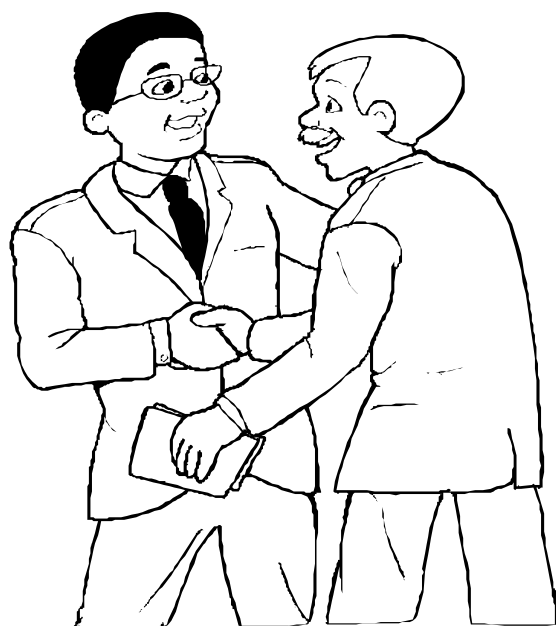

h e n

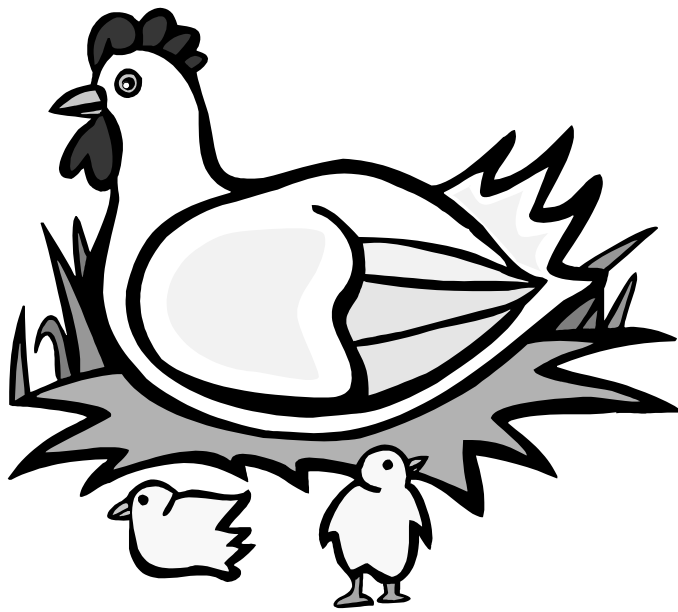

h e n

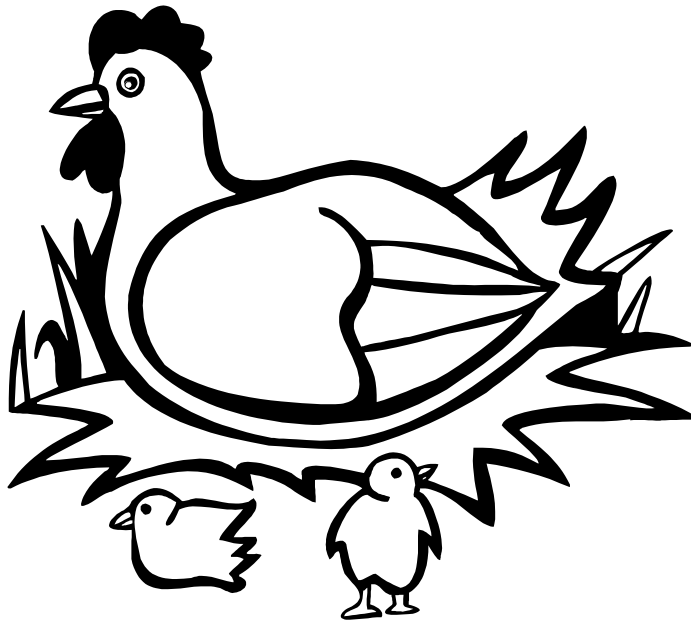

m e n



t e n



h e n

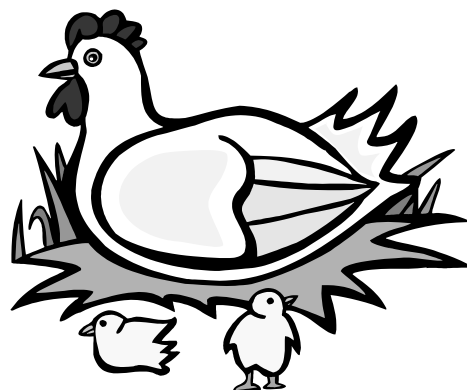

m e n

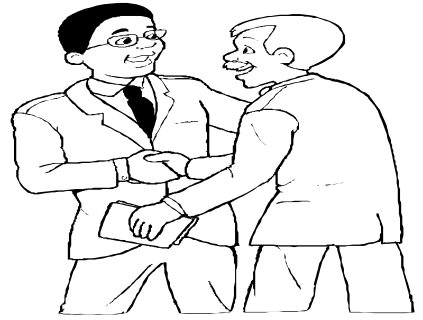

t e n

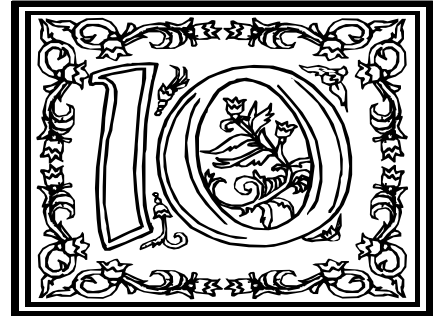

h e n

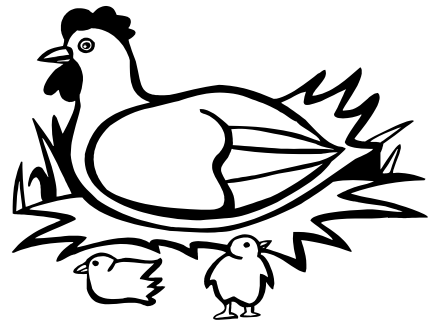

p e n

t e n

m e n

h e n

p e n

t e n

m e n

h e n

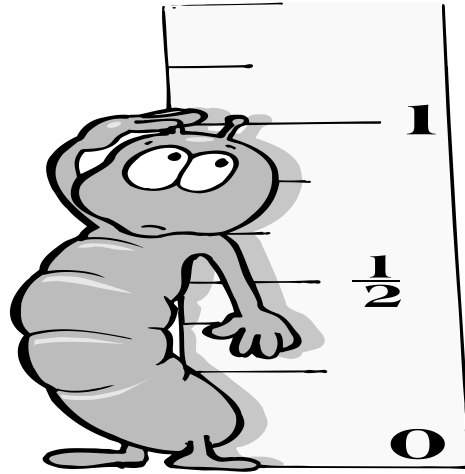

Parent prompt (suggested) - point and say,
"Inch starts with /i/ and sounds like "ih",
"inch - i - ih." Have your child repeat it - pointing.
Head for the coloring page, for both fun and to reinforce the lesson !

I i

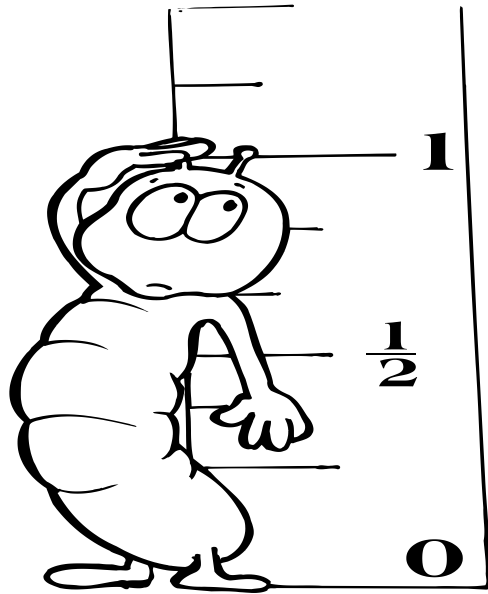

i n

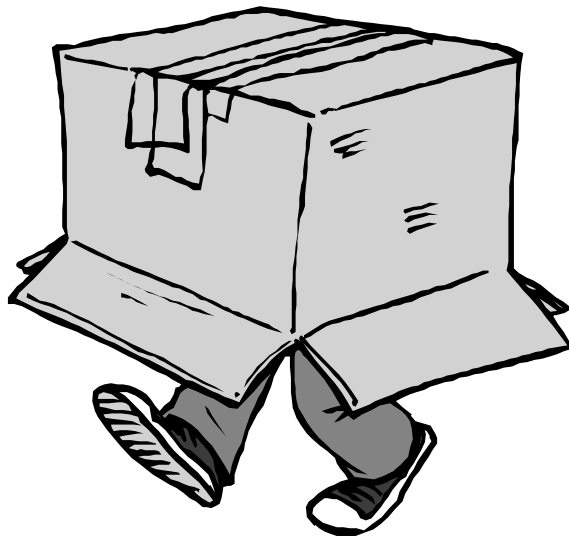

i n

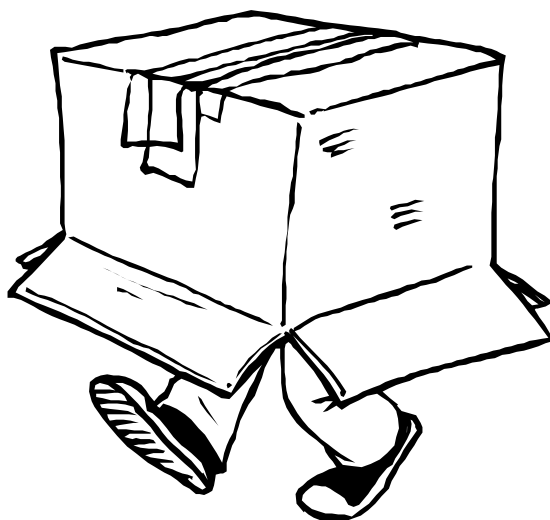

pin

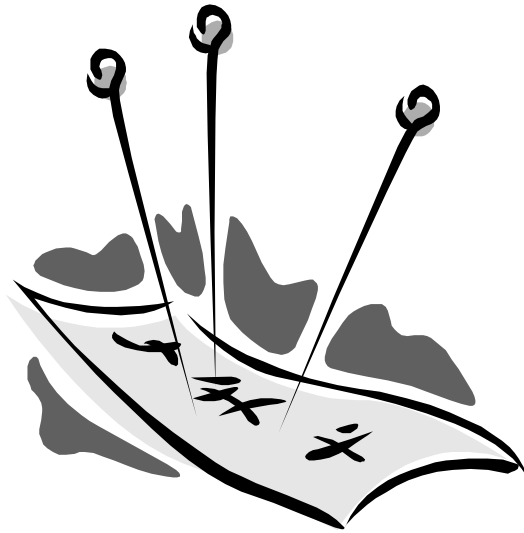

pin

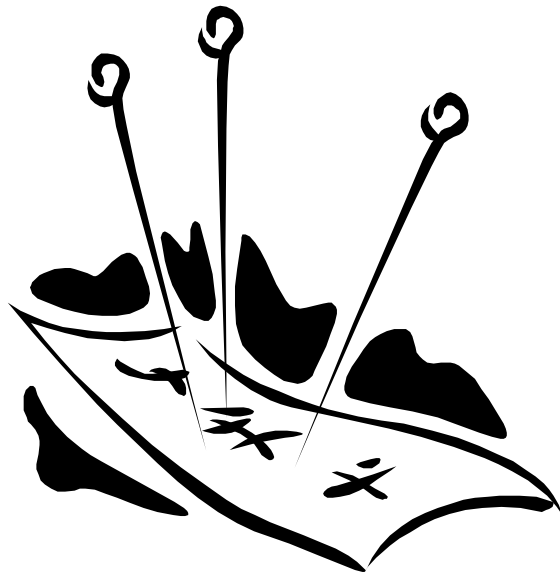

i -

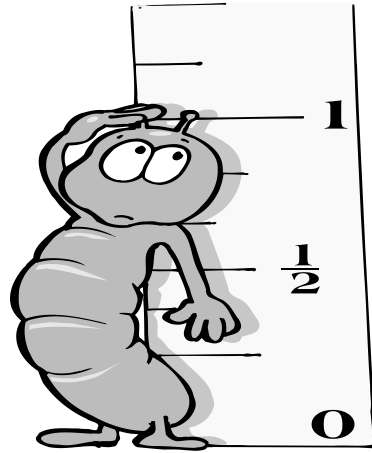

in

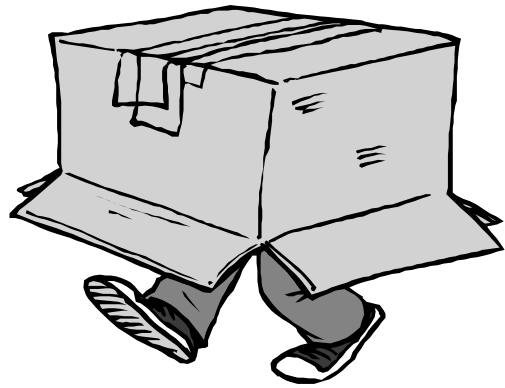

pin

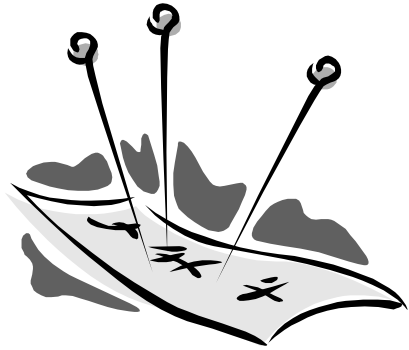

i -

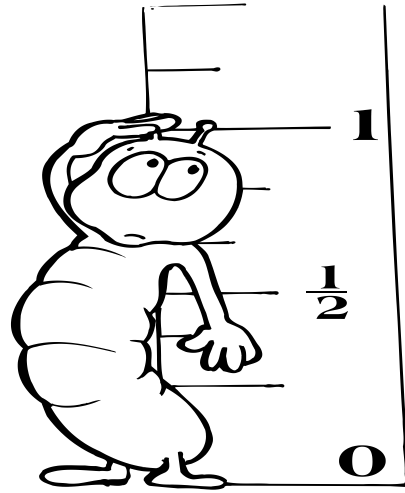

in

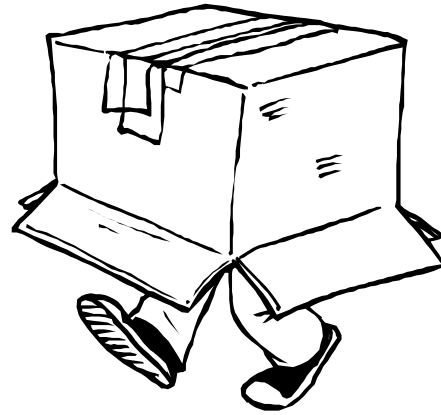

pin

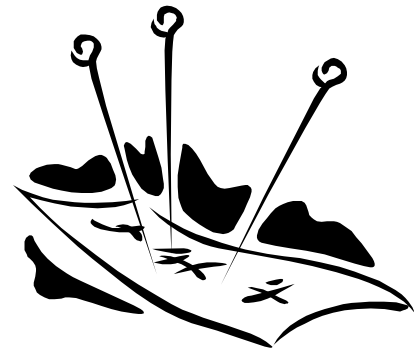

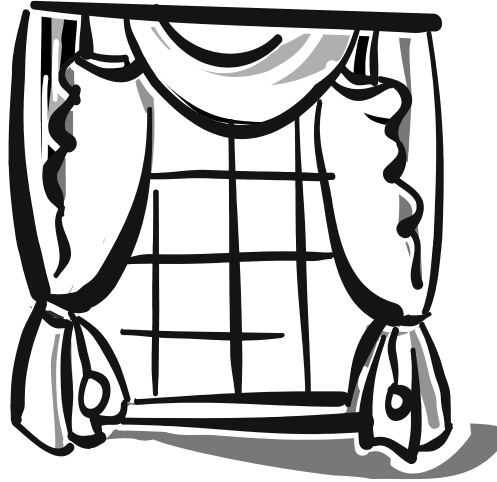

W

Parent prompt (suggested) - point and say,
"Window starts with /w/ and sounds like "wuh",
"window - w - wuh." Have your child repeat it - pointing.
Head for the coloring page, for both fun and to reinforce the lesson!

W w

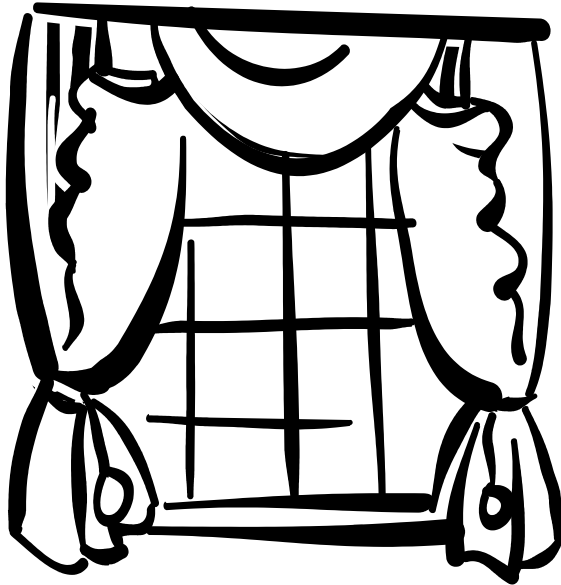

w i n

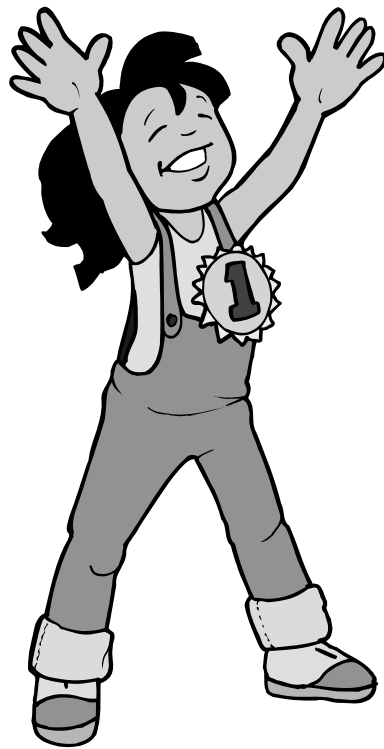

w i n



b i n

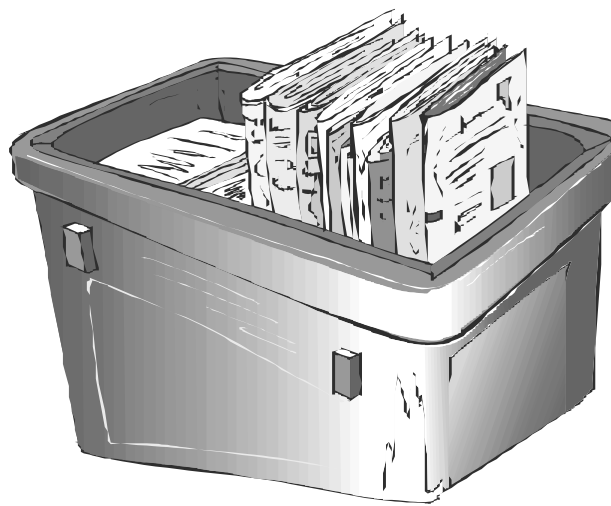

b i n

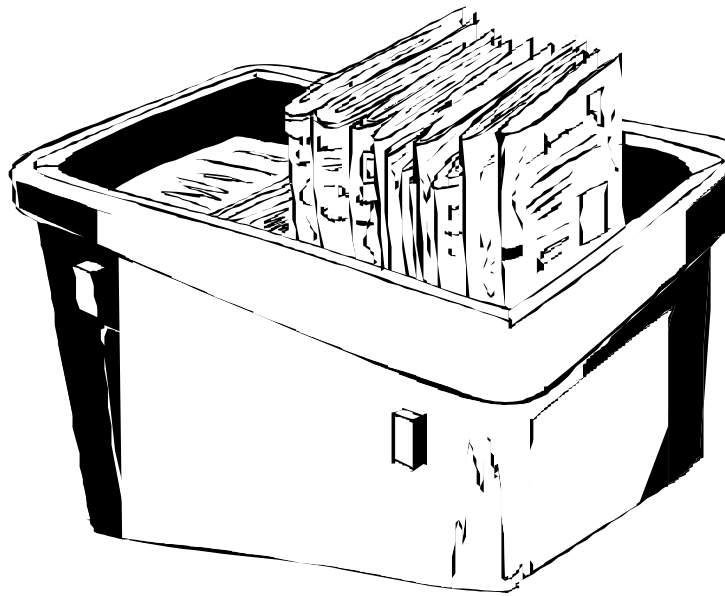

w -

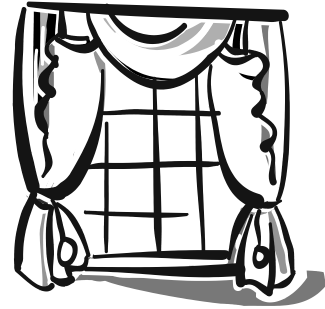

win



bin

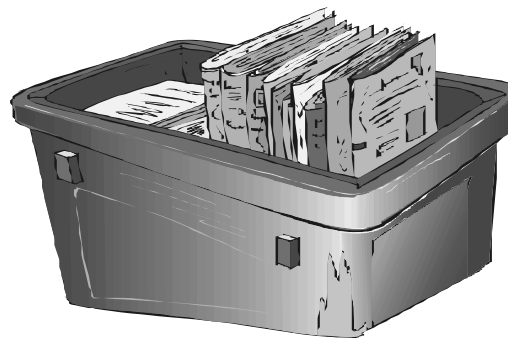

w -

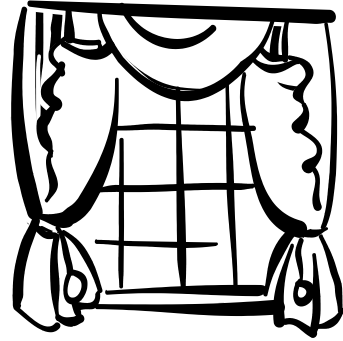

w i n



b i n

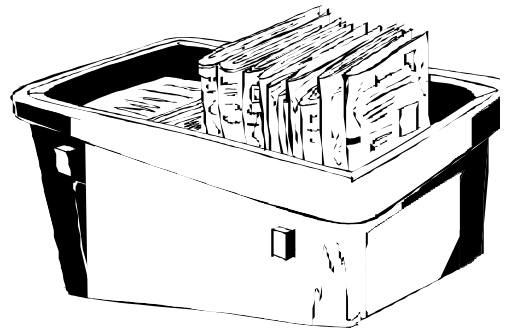

i n

p i n

w i n

b i n

i n

p i n

w i n

b i n

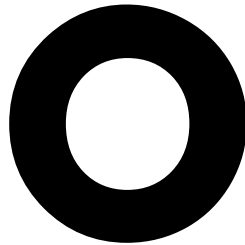
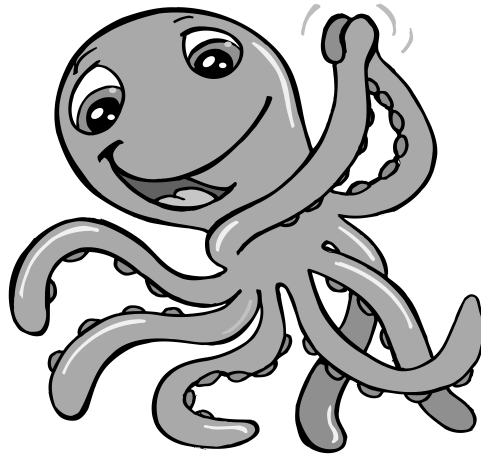

Parent prompt (suggested) - point and say,
**"Octopus starts with /o/ and sounds like "ah",
"octopus - o - ah."** Have your child repeat it - pointing.
Head for the coloring page, for both fun and to reinforce the lesson!

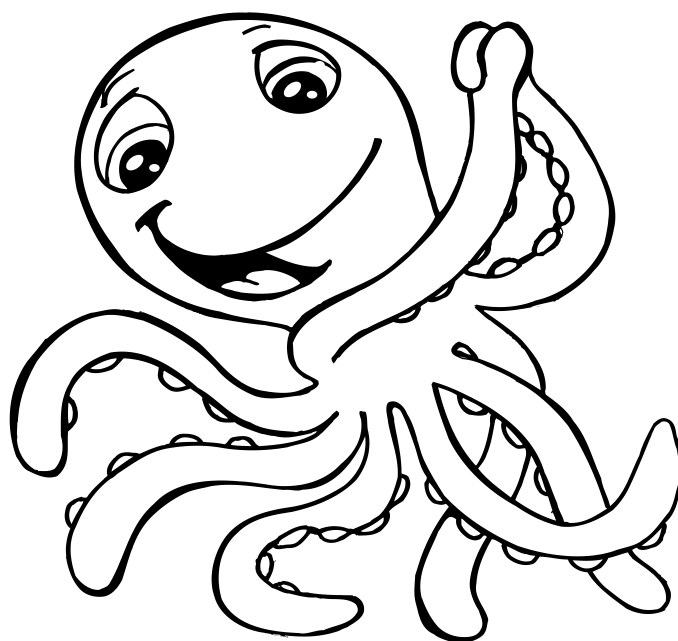
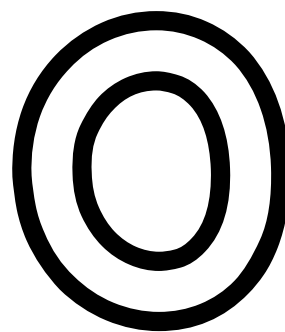
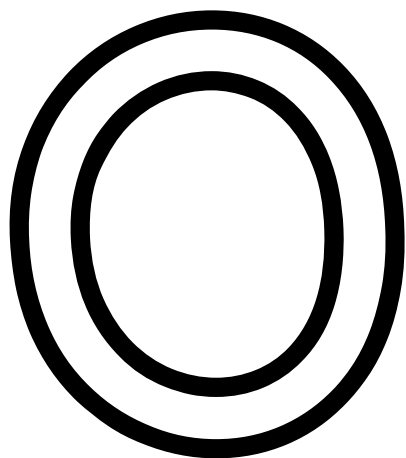

o n



o n



m o m



m o m



o -

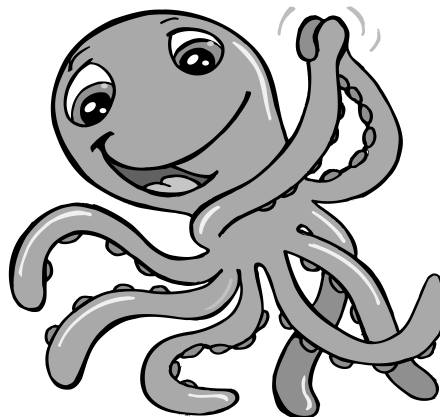

o n



m o m



o

-

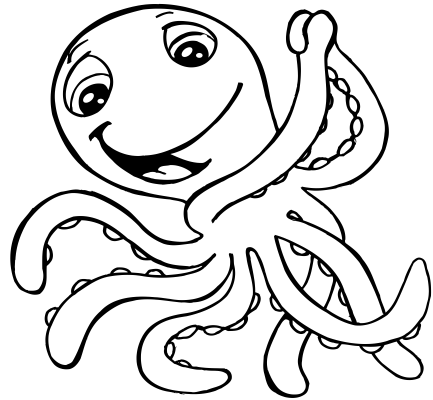

o

n



m

o

m



h o p



h o p

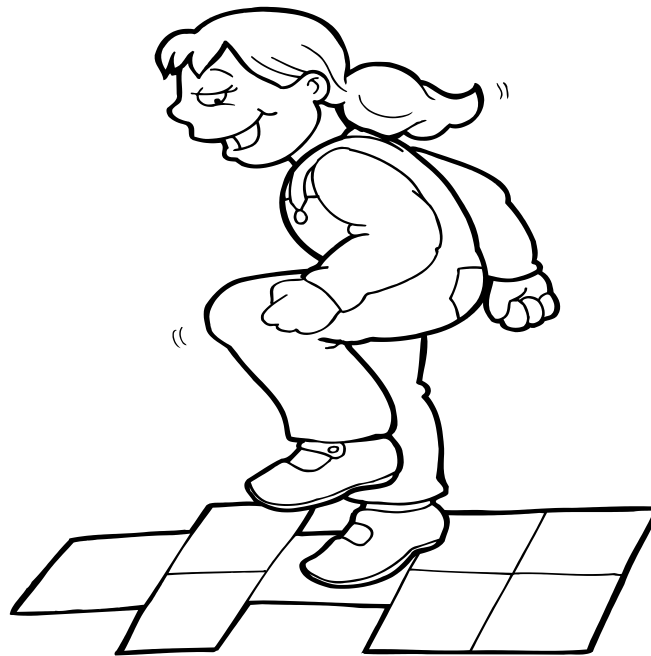

m o p



m o p



pop



p o p



h o p



m o p



p o p



h o p

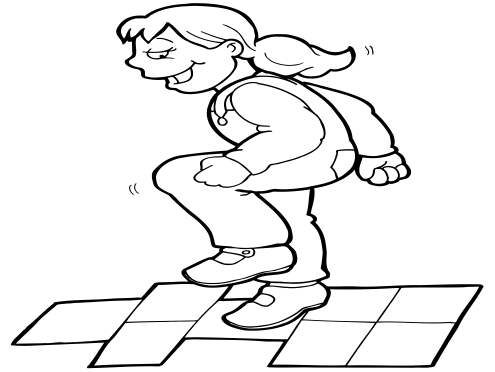

m o p



p o p



o n

m o m

m o p

h o p

p o p

o n

m o m

m o p

h o p

p o p



u

Parent prompt (suggested) - point and say,
**"Umbrella starts with /u/ and sounds like "uh",
"umbrella - u - uh."** Have your child repeat it - pointing.
Head for the coloring page, for both fun and to reinforce the lesson!

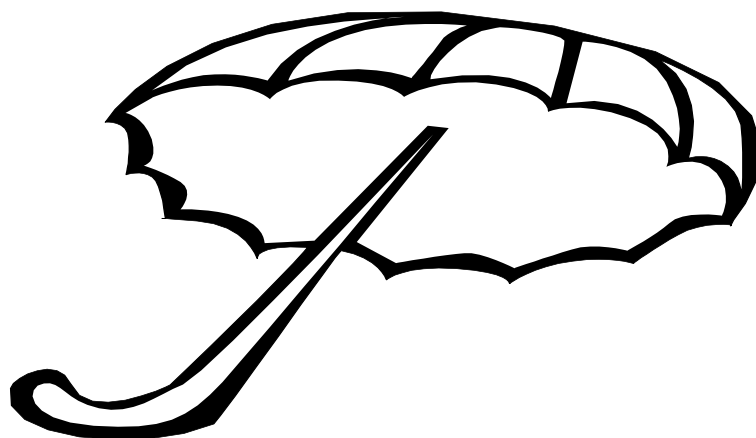
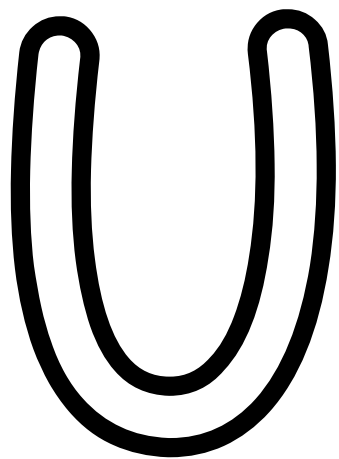

u p

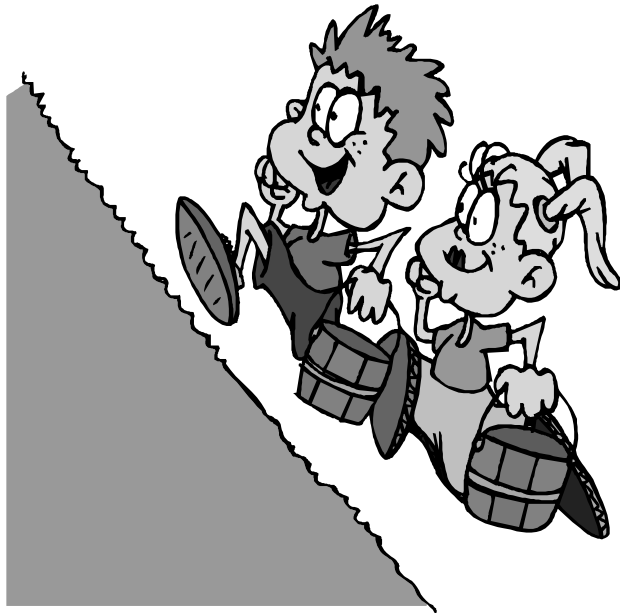

и р

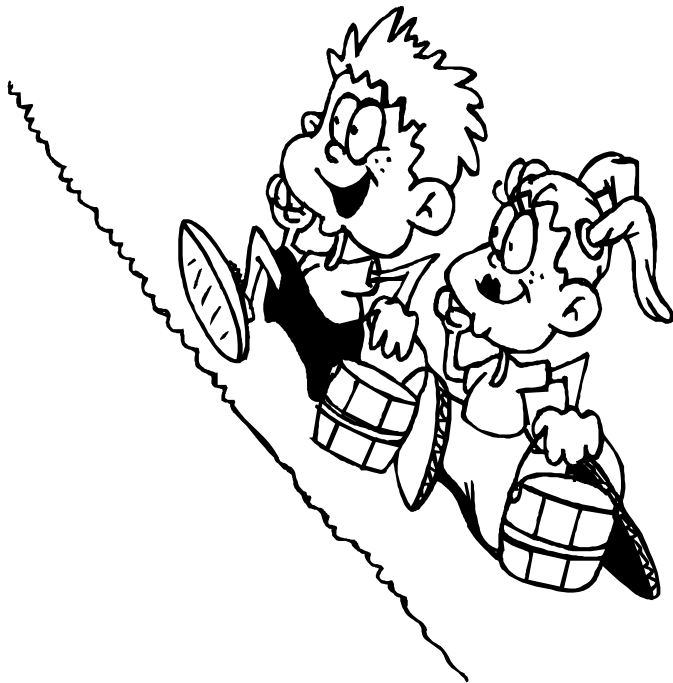

c u p



с и р



и -



и р



с и р



и -

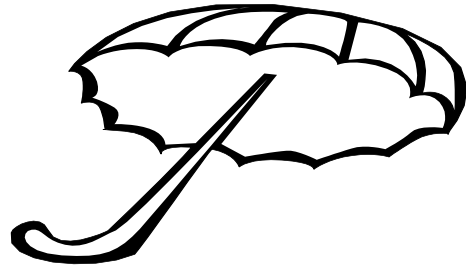

и р

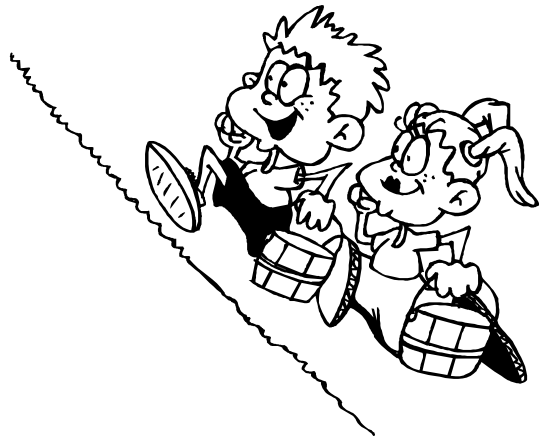

с и р



p u p



р и р



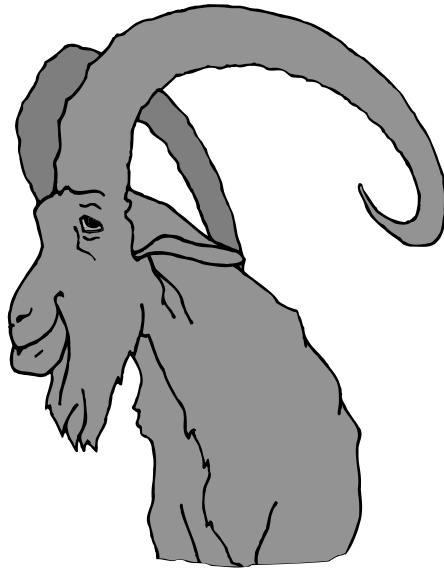

g

Parent prompt (suggested) - point and say,
"Goat starts with /g/ and sounds like "guh",
"goat - g - guh." Have your child repeat it - pointing.
Head for the coloring page, for both fun and to reinforce the lesson!

G

g



g u m



g u m



p u p



g -



g u m



p u p



g -



g u m



и р

с и р

р и р

г и т

и р

с и р

р и р

г и м

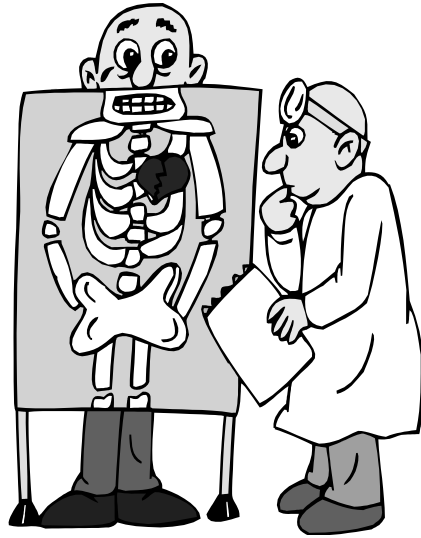

X

Parent prompt (suggested) - point and say,
"X-ray starts with /x/ and sounds like "eks",
"x-ray - x - eks." Have your child repeat it - pointing.
Head for the coloring page, for both fun and to reinforce the lesson!

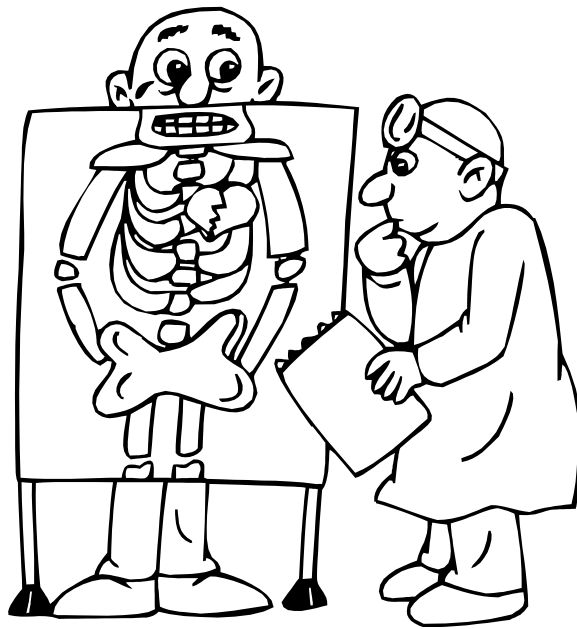
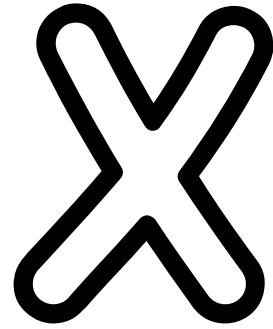

a x

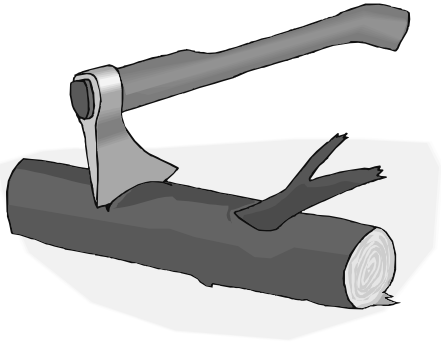

a x

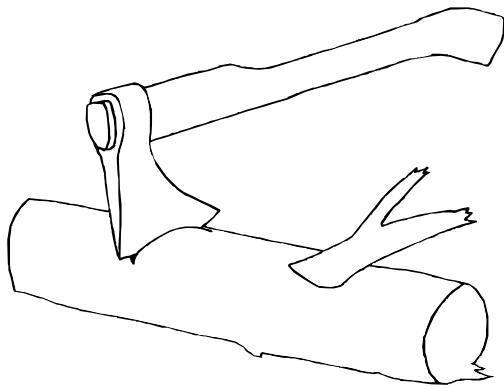

sit on mat

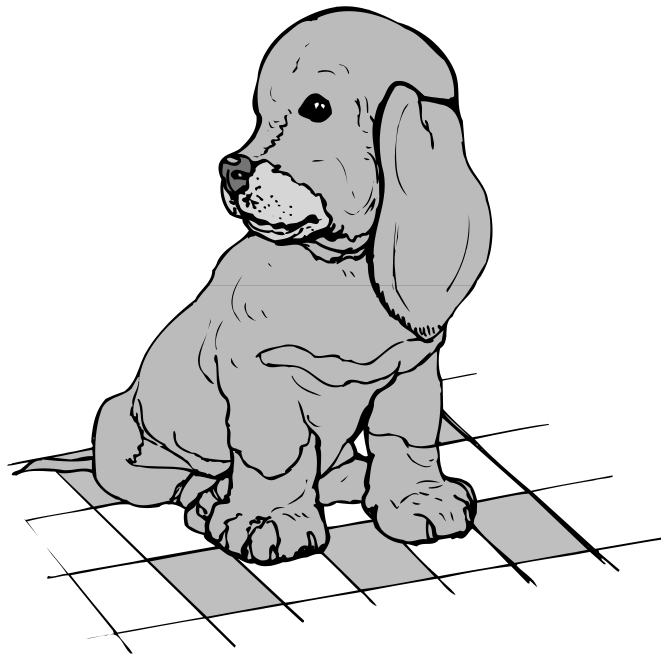

sit on mat

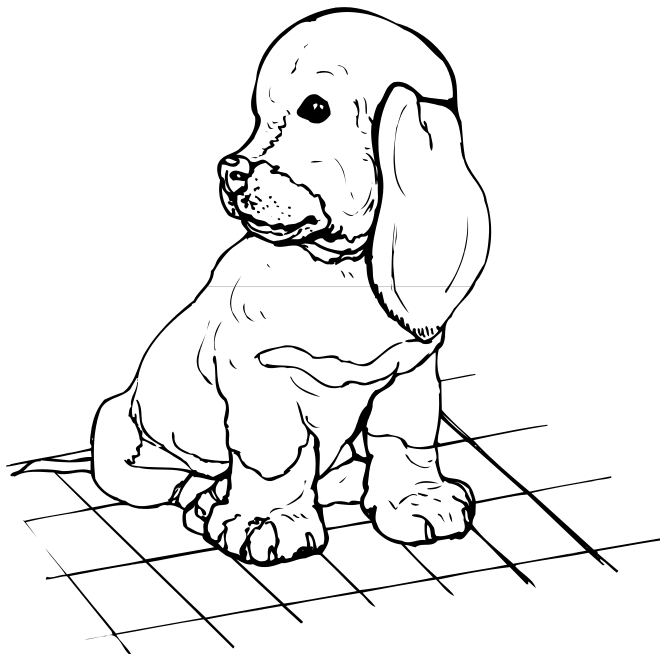



pin hat on mom



pin hat on mom

O X

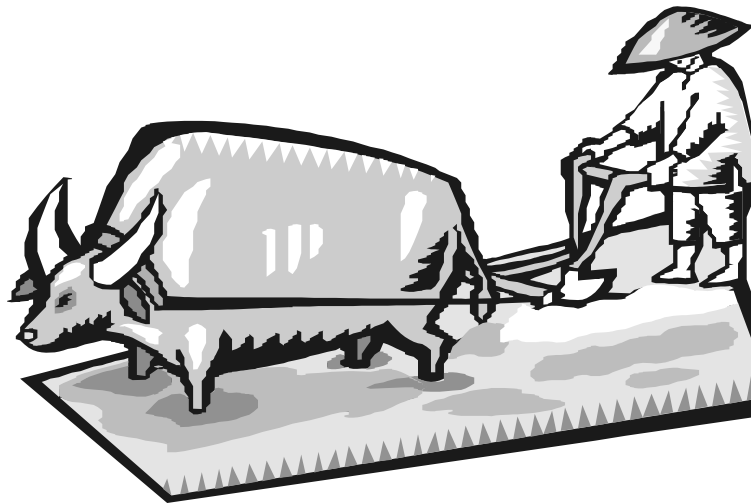

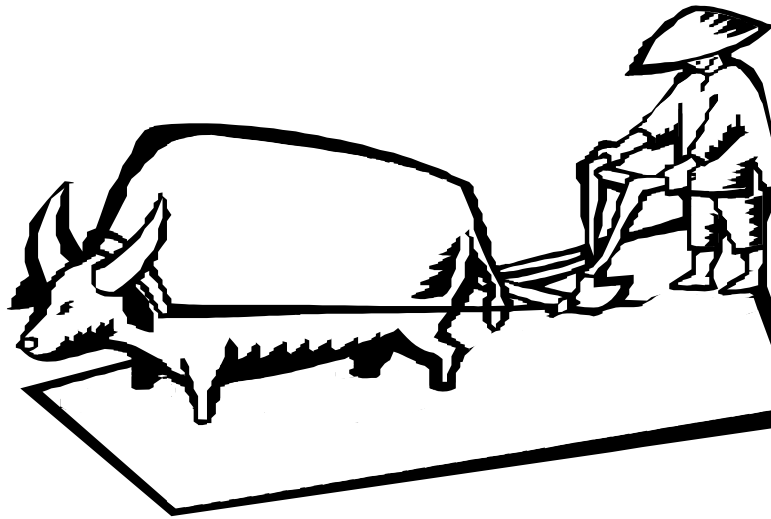
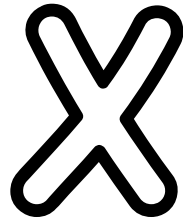
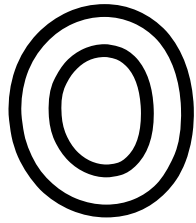

x -

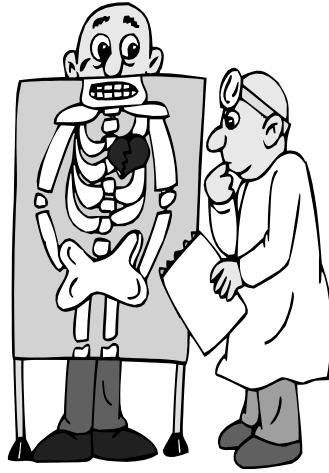

ax

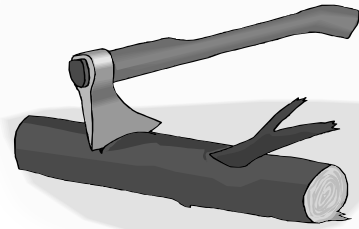

ox

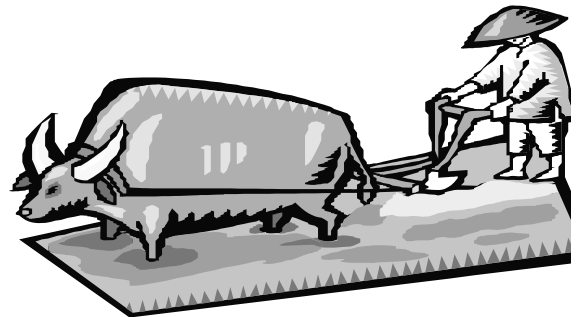

x -

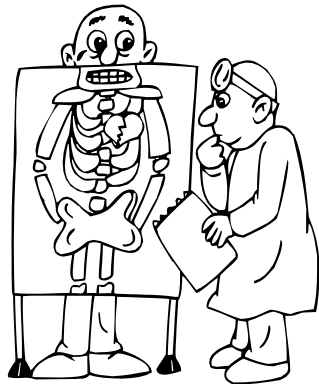

a x

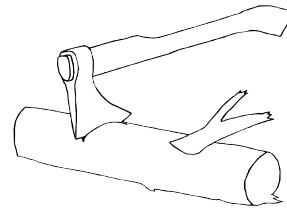

o x

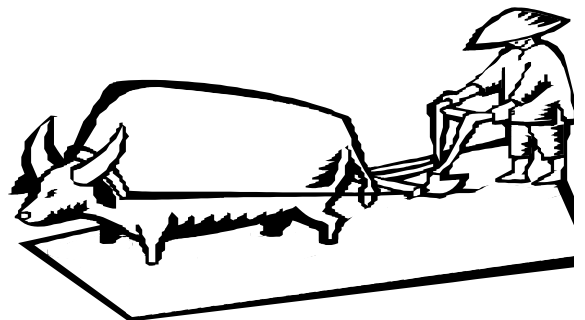

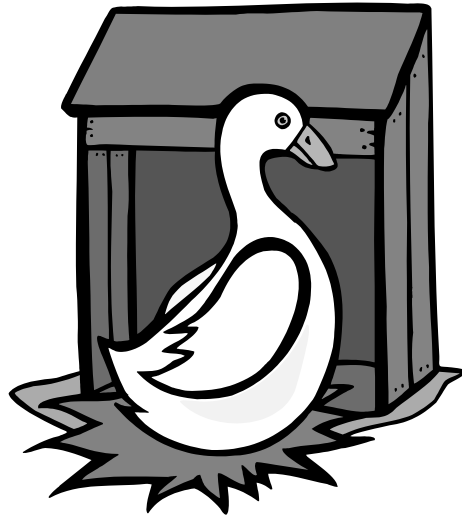

d

Parent prompt (suggested) - point and say,
"Duck starts with /d/ and sounds like "duh",
"duck - d - duh." Have your child repeat it - pointing.
Head for the coloring page, for both fun and to reinforce the lesson!

D d

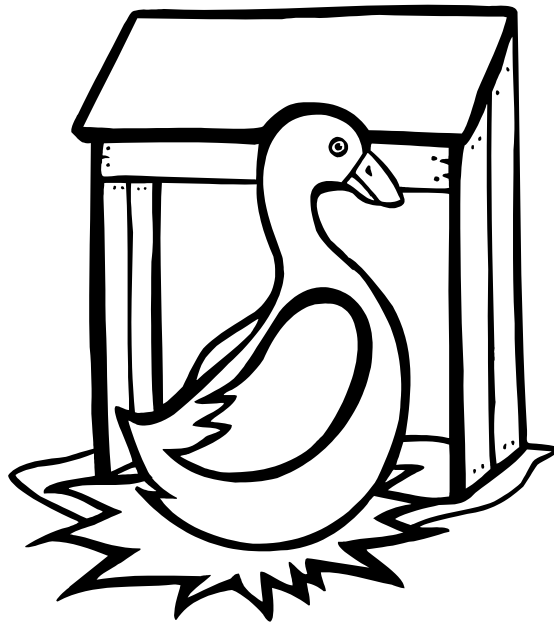

d a d



d a d



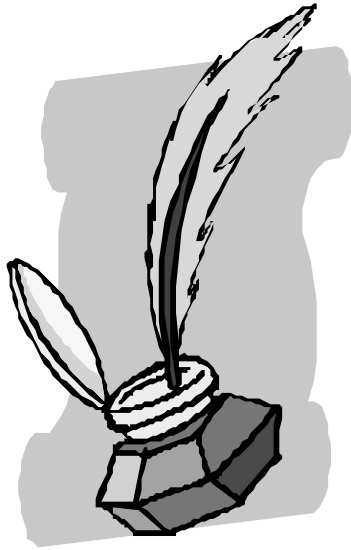

f

Parent prompt (suggested) - point and say,
***"Feather starts with /f/ and sounds like "eff",
"feather - f - eff."*** Have your child repeat it - pointing.
Head for the coloring page, for both fun and to reinforce the lesson !

F F

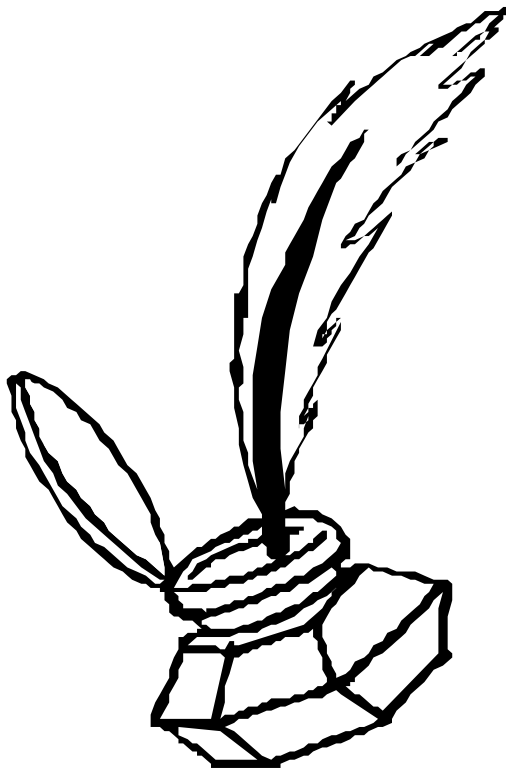

d -

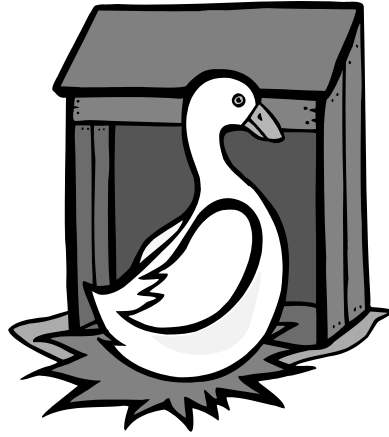

d a d



f -

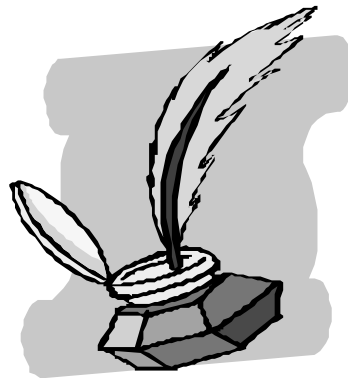

d -

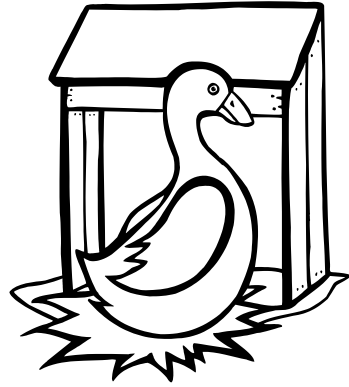

d a d



d -

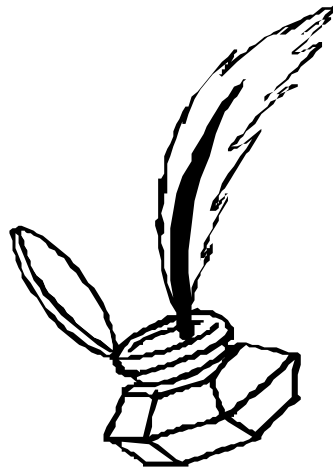

f a n



F a n

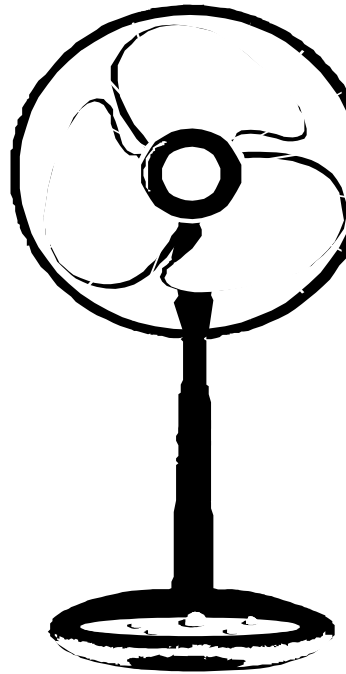



V

Parent prompt (suggested) - point and say,
**"Vacuum starts with /v/ and sounds like "vuh",
"vacuum - v - vuh."** Have your child repeat it - pointing.
Head for the coloring page, for both fun and to reinforce the lesson !

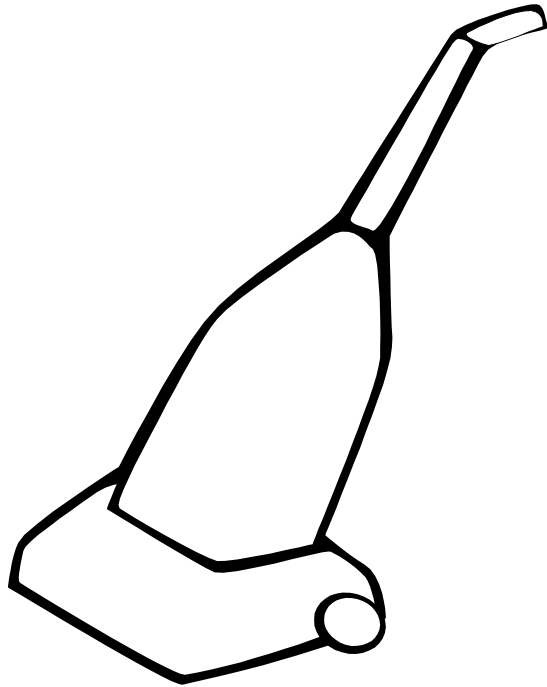
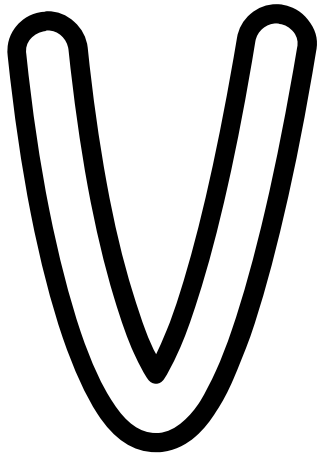

v a n



v a n

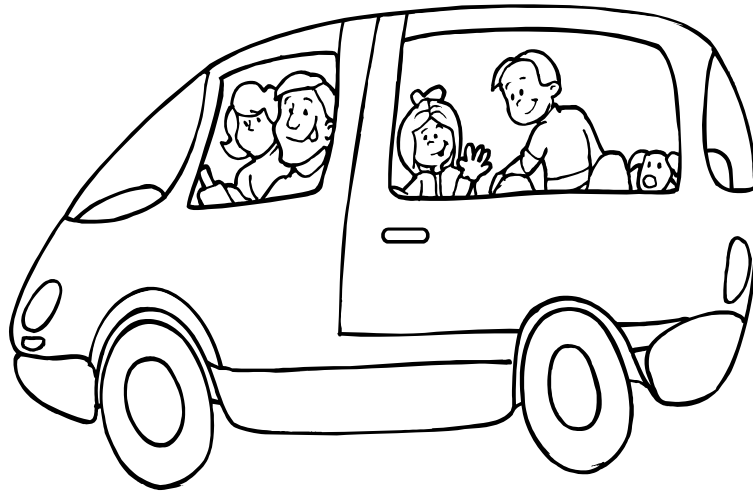

f a n



v -



v a n



F a n

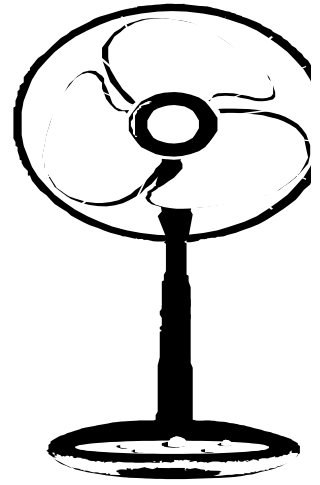

v -

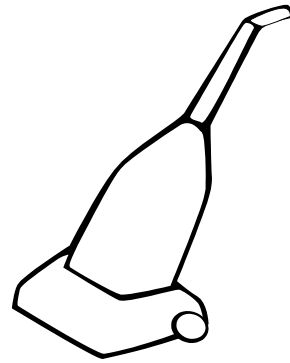

v a n

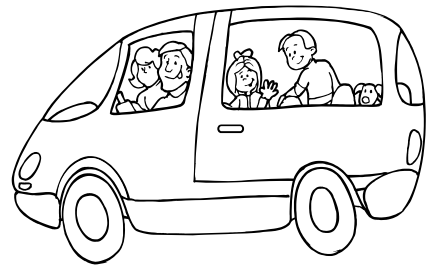

a x

o x

d a d

f a n

v a n

a x

o x

d a d

f a n

v a n



j

Parent prompt (suggested) - point and say,
"Jogger starts with /j/ and sounds like "juh",
"jogger - j - juh." Have your child repeat it - pointing.
Head for the coloring page, for both fun and to reinforce the lesson!

J j

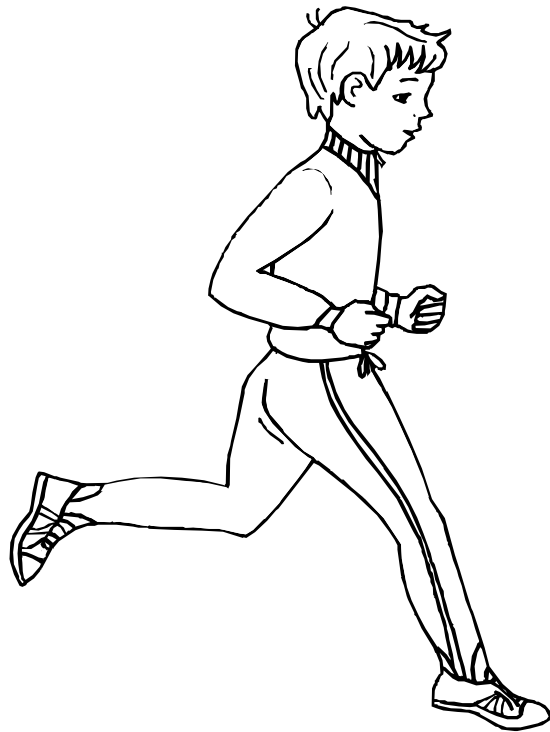

jet

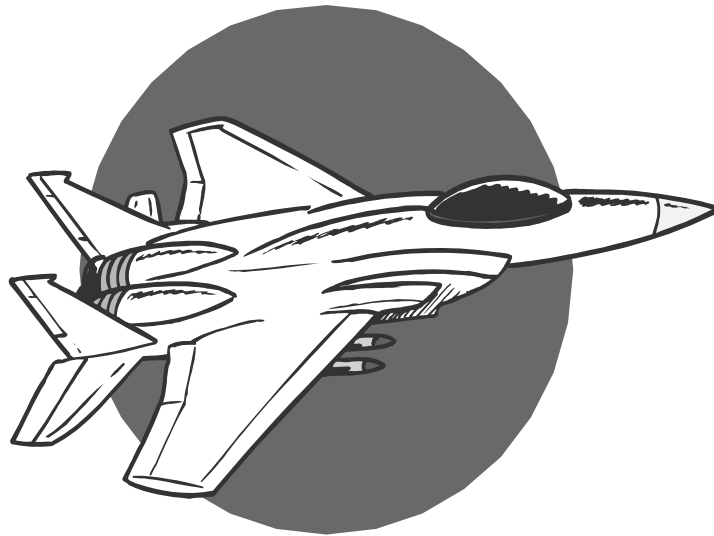

j e t

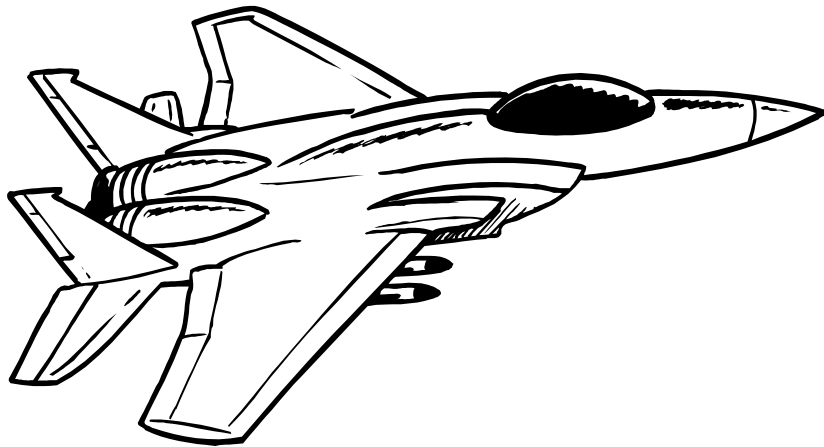

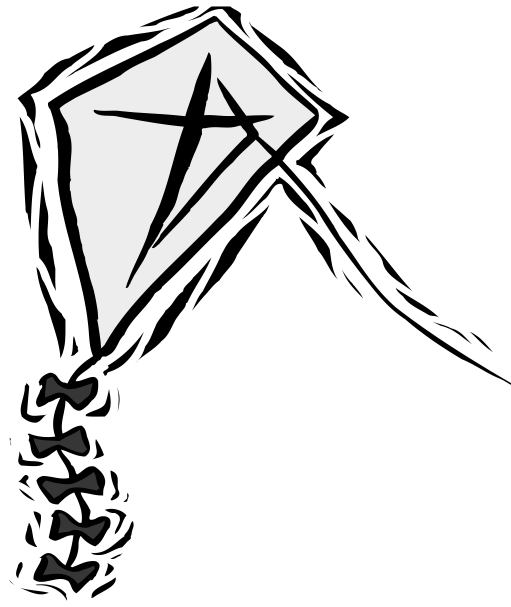

k

Parent prompt (suggested) - point and say,
***"Kite starts with /k/ and sounds like "kuh",
"kite - k - kuh."*** Have your child repeat it - pointing.
Head for the coloring page, for both fun and to reinforce the lesson !

K K

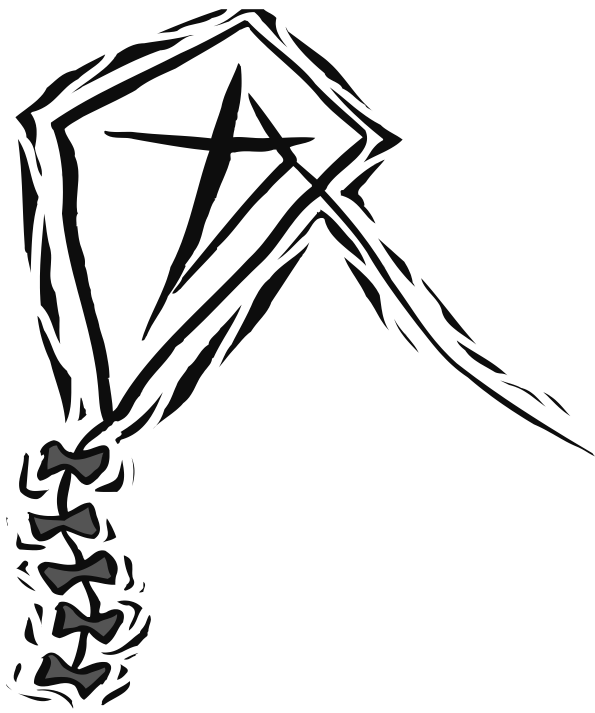

j .



jet

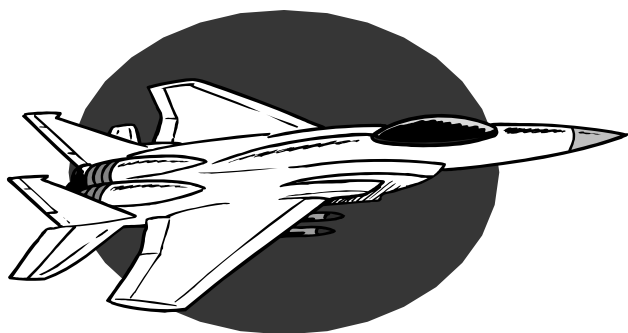

k .

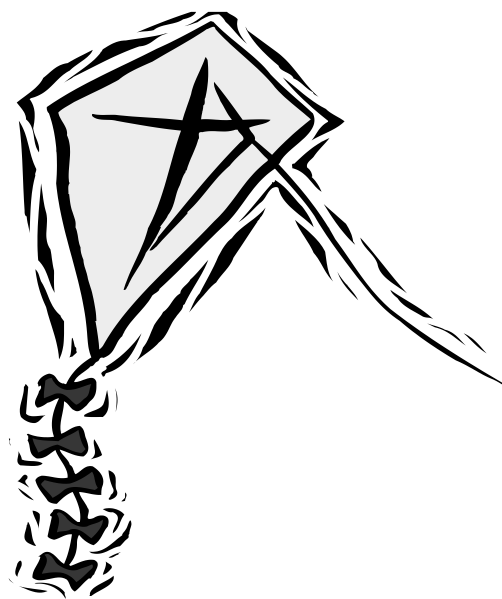

j -

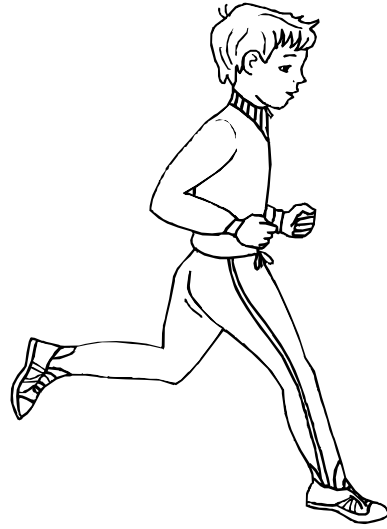

jet +

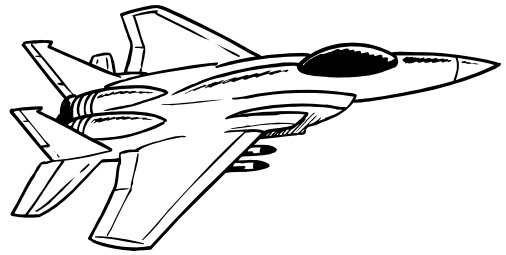

k -



kit



k i t



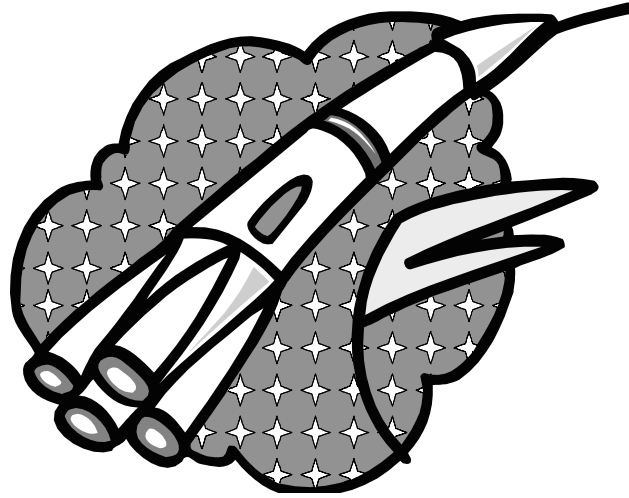

r

Parent prompt (suggested) - point and say,
"Rocket starts with /r/ and sounds like "err",
"rocket - r - err." Have your child repeat it - pointing.
Head for the coloring page, for both fun and to reinforce the lesson!

R r

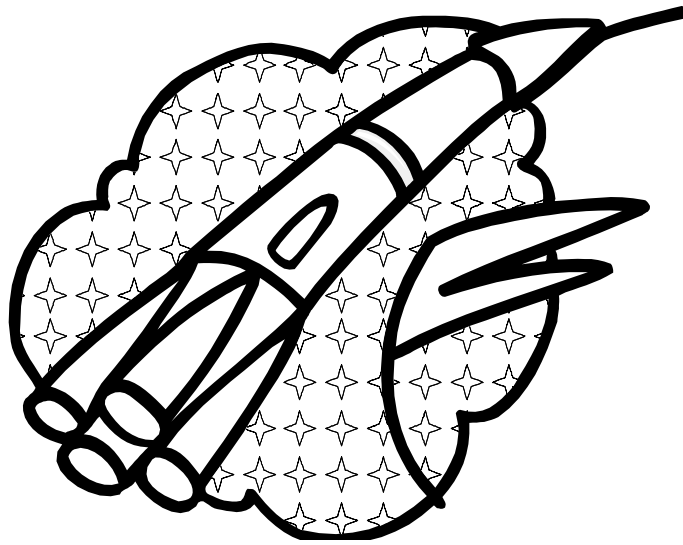

run



r u n



kit



r -

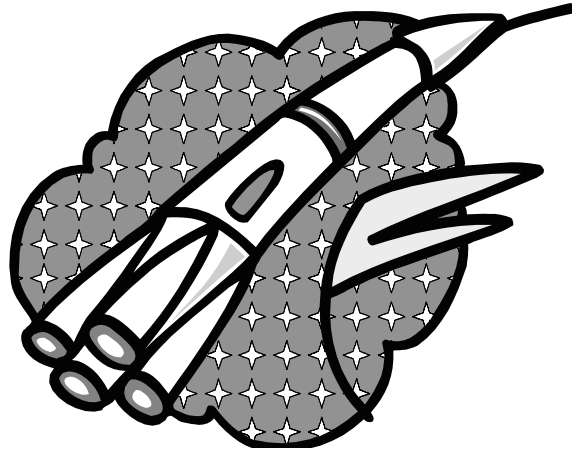

run



k i t



r -

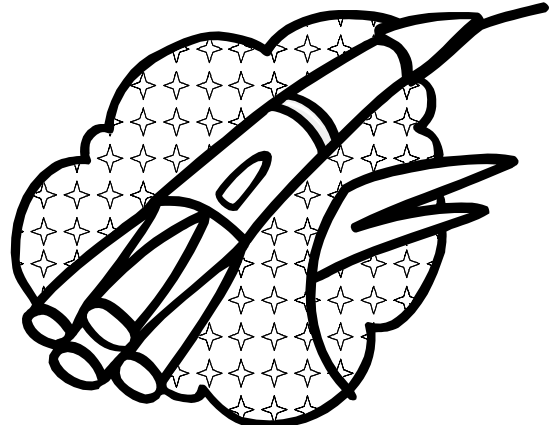

r u n



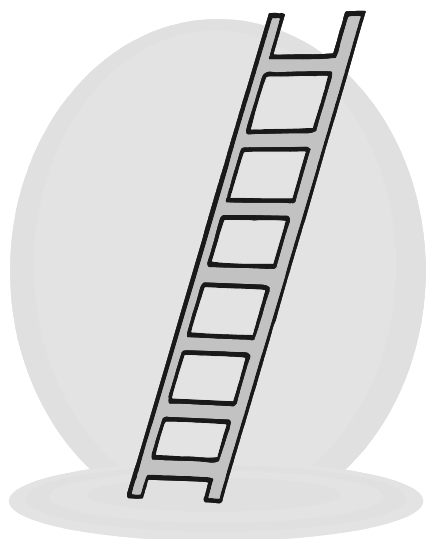

L

Parent prompt (suggested) - point and say,
***"Ladder starts with /L/ and sounds like 'lll',
"ladder - l - lll."*** Have your child repeat it - pointing.
Head for the coloring page, for both fun and to reinforce the lesson!

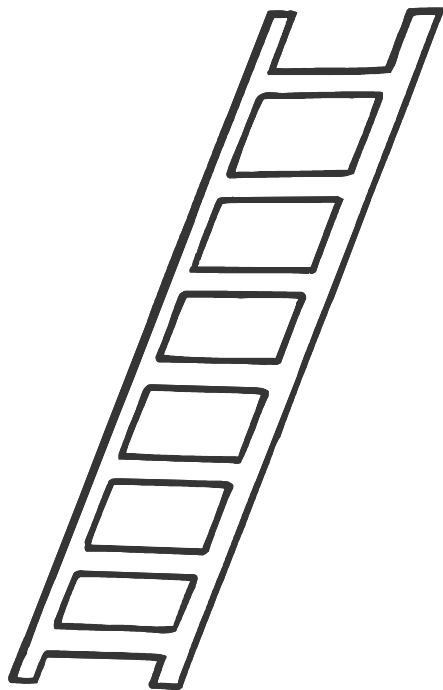
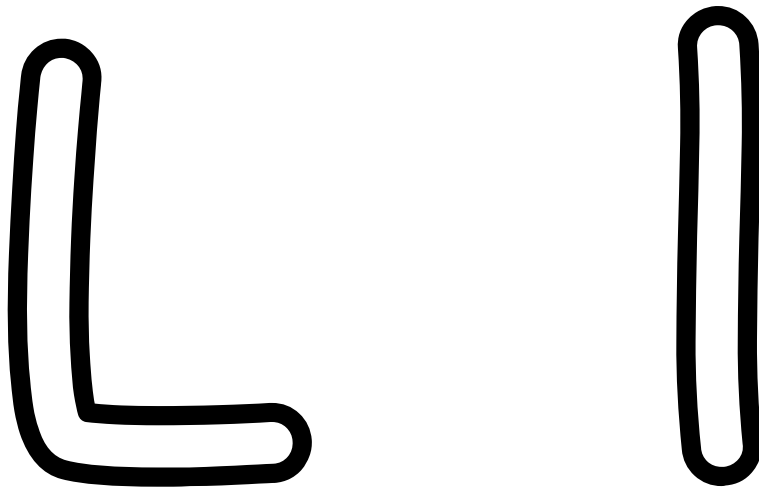

lid



l i d

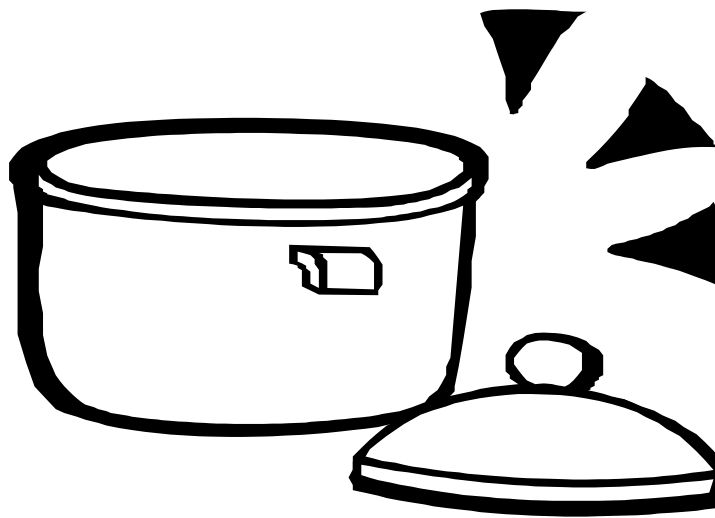

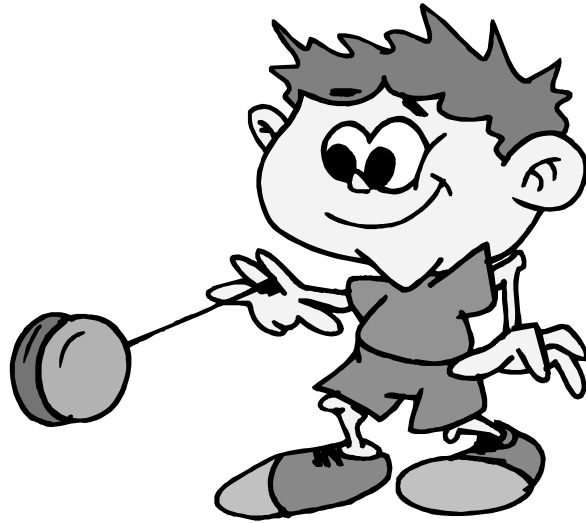

Y

Parent prompt (suggested) - point and say,
"Yoyo starts with /y/ and sounds like "yuh",
"yoyo - y - yuh." Have your child repeat it - pointing.
Head for the coloring page, for both fun and to reinforce the lesson!

Y

y

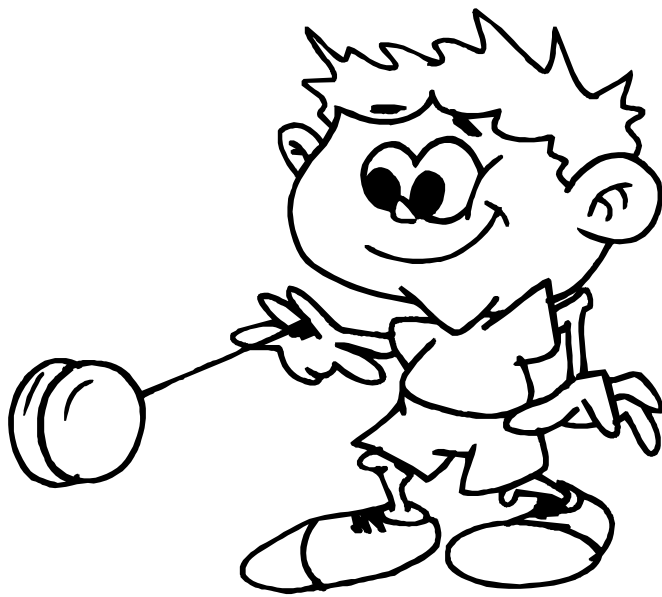

l -

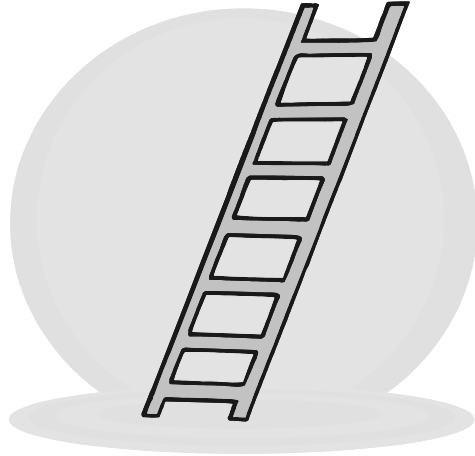

lid

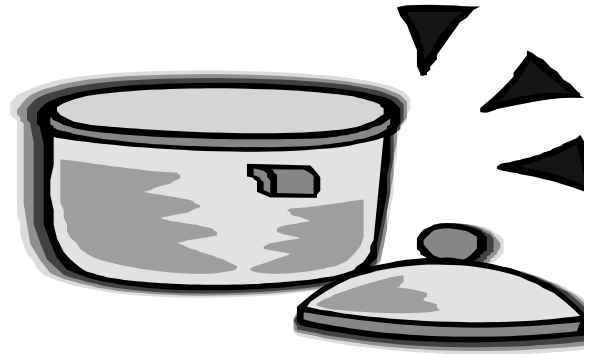

y -

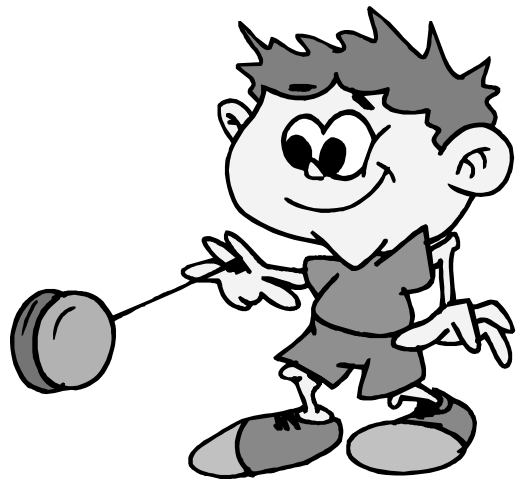

l -

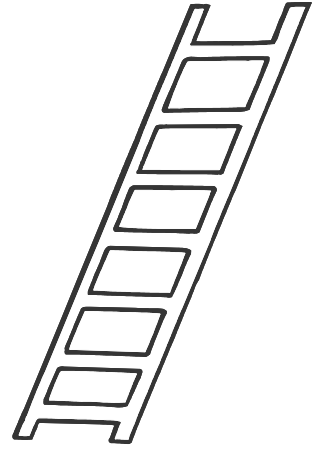

lid

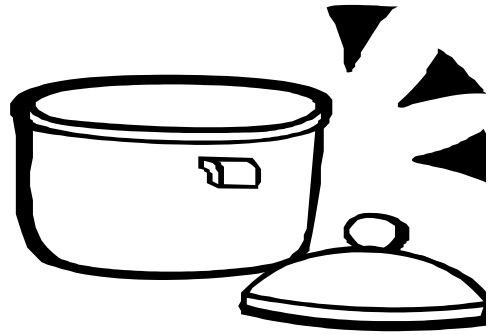

y -

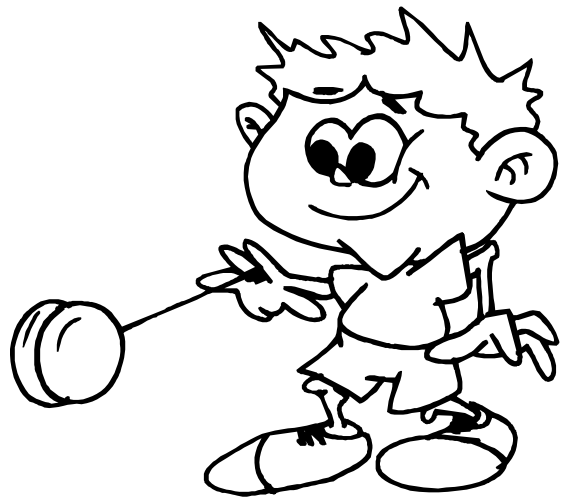

yes

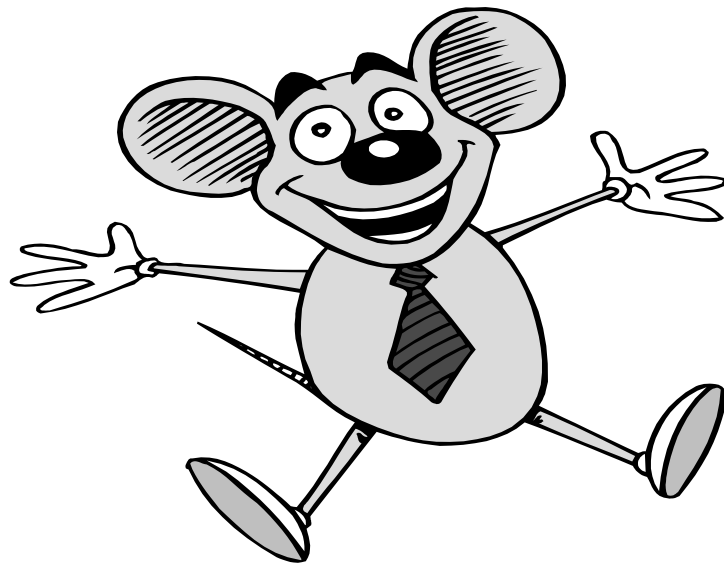

y e s

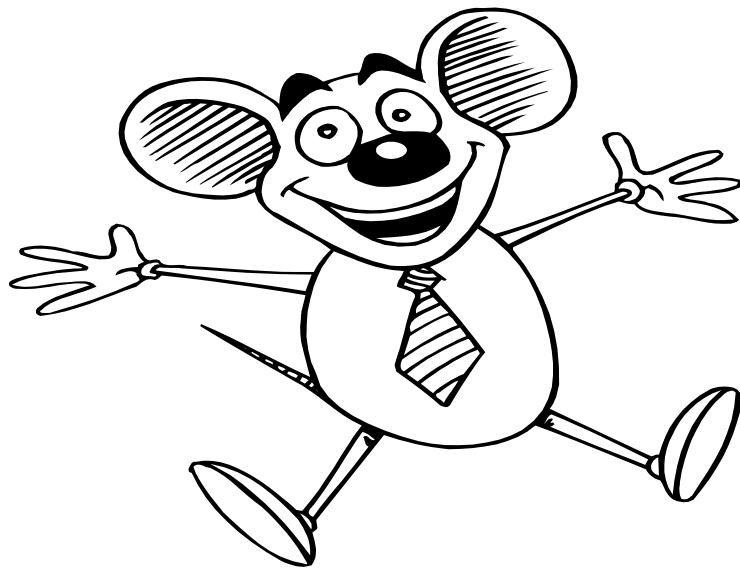



Z

Parent prompt (suggested) - point and say,
***"Zebra starts with /z/ and sounds like "zuh",
"zebra - z - zuh."*** Have your child repeat it - pointing.
Head for the coloring page, for both fun and to reinforce the lesson!

Z z

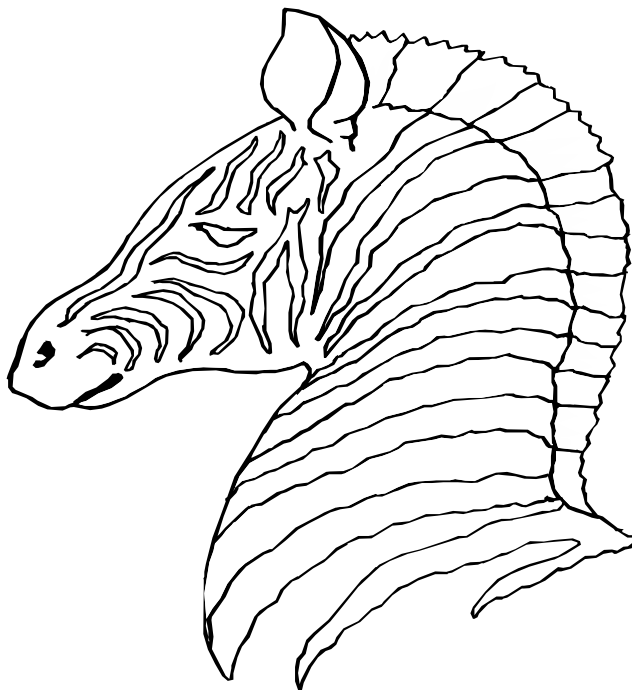

zip

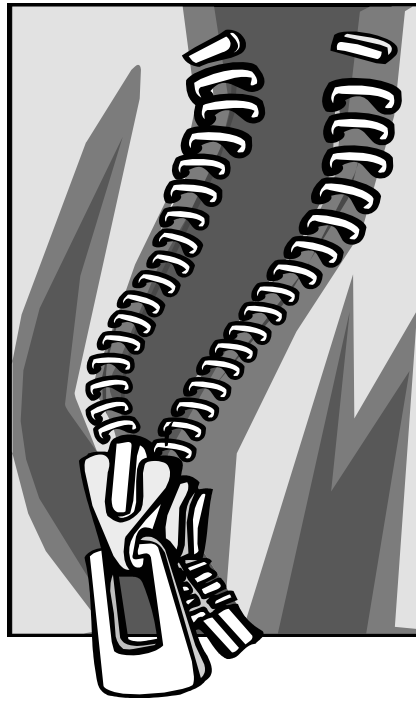

zip

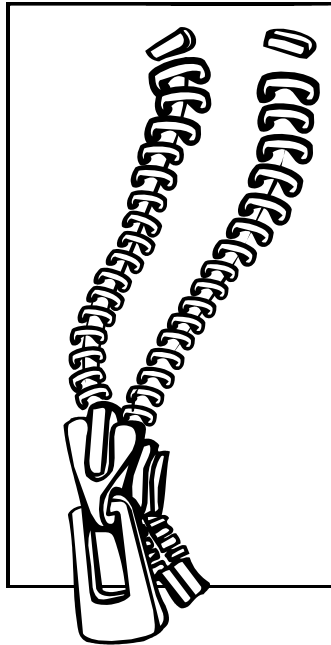

y e s

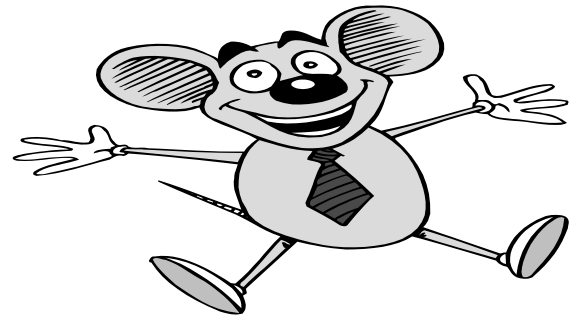

z -



z i p

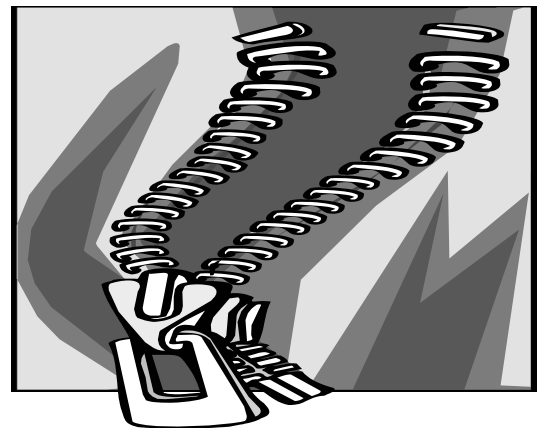

y e s

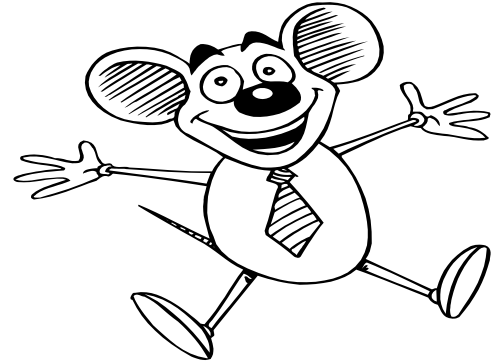

z -

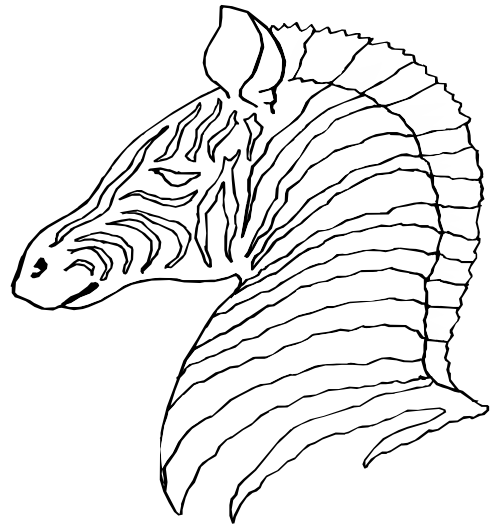

z i p

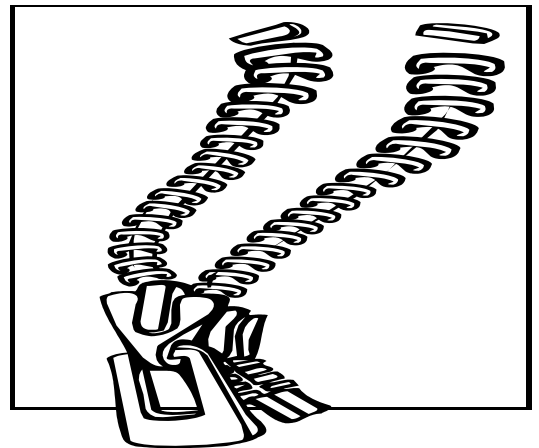

jet

kit

run

lid

yes

zip

jet

kit

run

lid

yes

zip

STOP

CONGRATULATIONS!

You have just reached the end of
Section 1 - Short Vowel Book Skills.

The Next Step

We suggest a short break, followed by a week or two of reading just short-vowel books. Then consider alternating days between short-vowel books and Section 2 - Long Vowels, Blends, & Segmenting of Big Words. Or you may also want to pick-up Section 2 skills "on the fly", as the need arises.

Caution!

Do be particular, at this juncture, about finding books with just short-vowel words. And don't just hand them over. Sit with them, still. The very last thing you want, at this point, is for your student to get discouraged. Note: there are a couple of series out there - that are pretty good about having just short-vowel words, including the "Now I'm Reading" Series, Level One, and "Bob Books" Sets 1 & 2. Both are available at Amazon. You may, also, want to check your local public library for these!

Section 2 - Long-Vowels, Blends, & Segmenting

Now that your student can read short-vowel books, it's time to give them the tools to read any beginning book, including:

- 1) To know long-vowels.
- 2) To know blends.
- 3) To know some sight words & punctuation.
- 4) To be able to break down bigger words.

How to Use: teach your student to use their thumb to cover part of the word, while sounding out the other part!

long - a

Say, "The 'e' is silent and makes the 'a' say its name."

bake@



cake@



rake

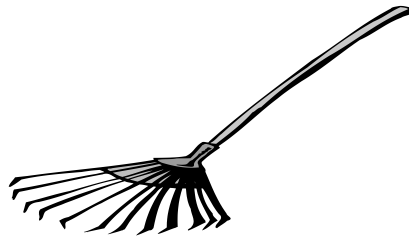

gate

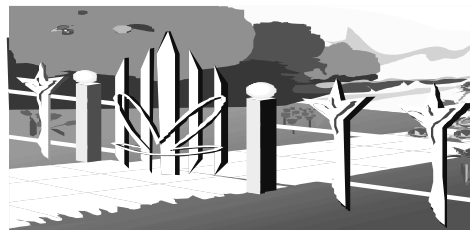

b a k e



c a k e

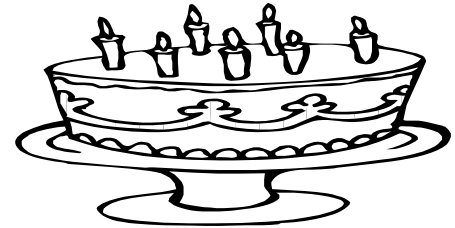

r a k e

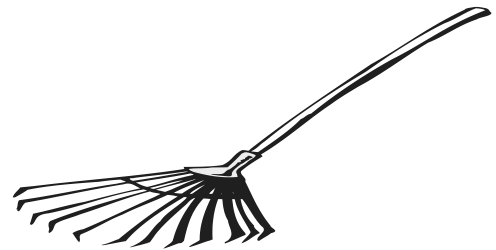

g a t e



long - i

Say, "The 'e' is silent and makes the 'i' say its name."

bike



hike



mike



kite



b i k e

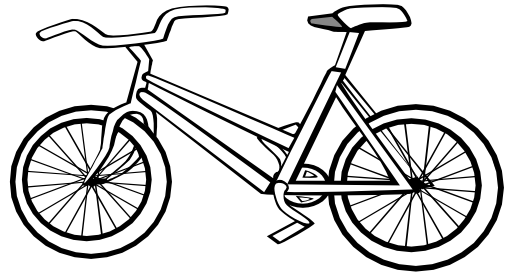

h i k e

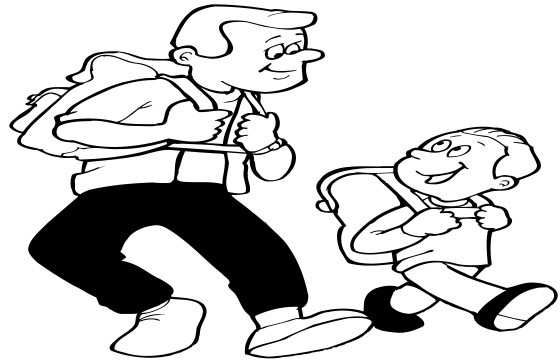

m i k e

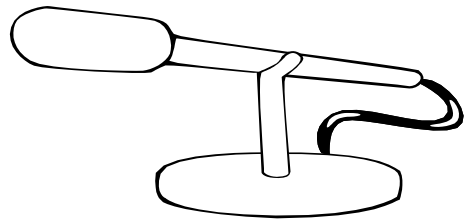

k i t e

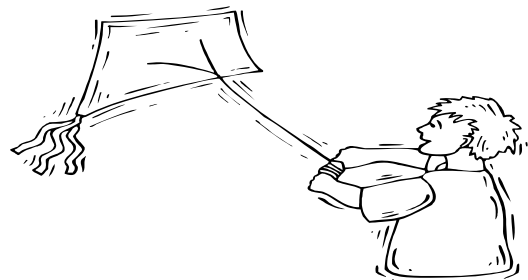

long - o

Say, "The 'e' is silent and makes the 'o' say its name."

hole @

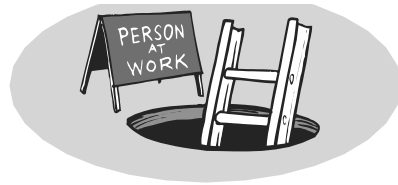

pole @

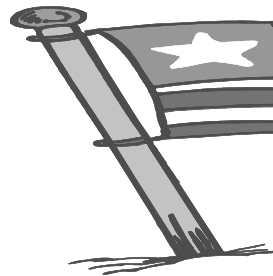

rope

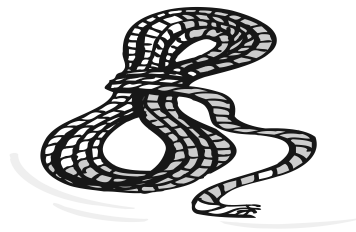

joke



hole



pole

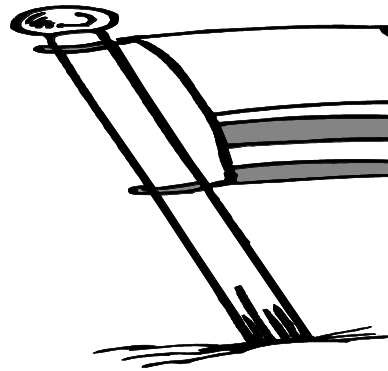

rope

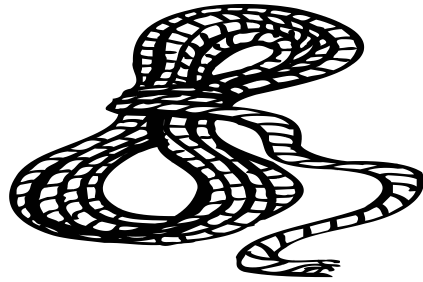

joke

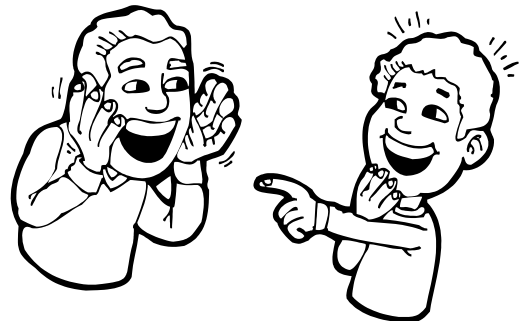

long - u

Say, "The 'e' is silent and makes the 'u' say its name."

cut^u

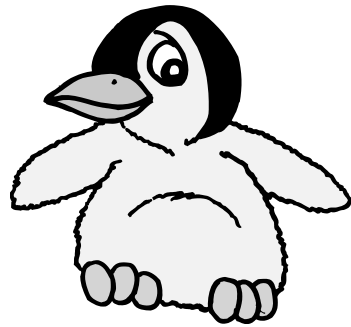

mul^u

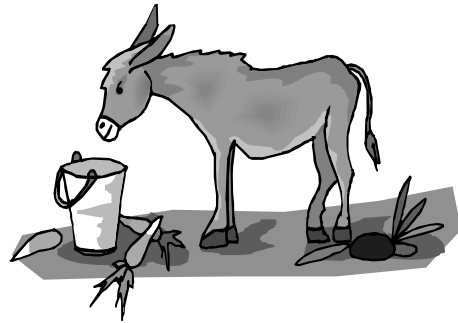

fume

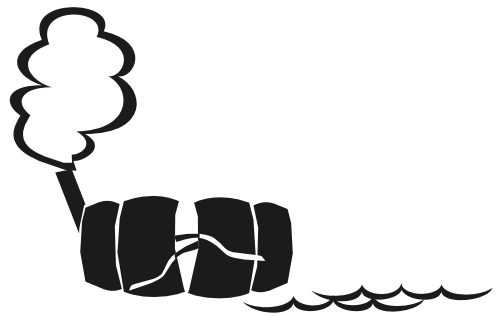

c u t e

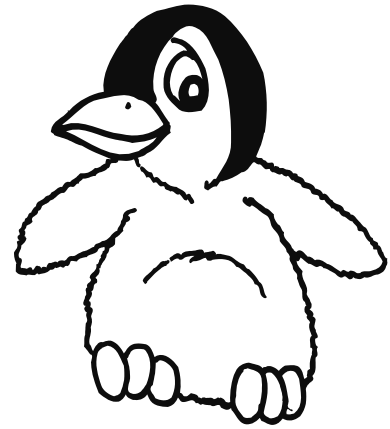

m u l e

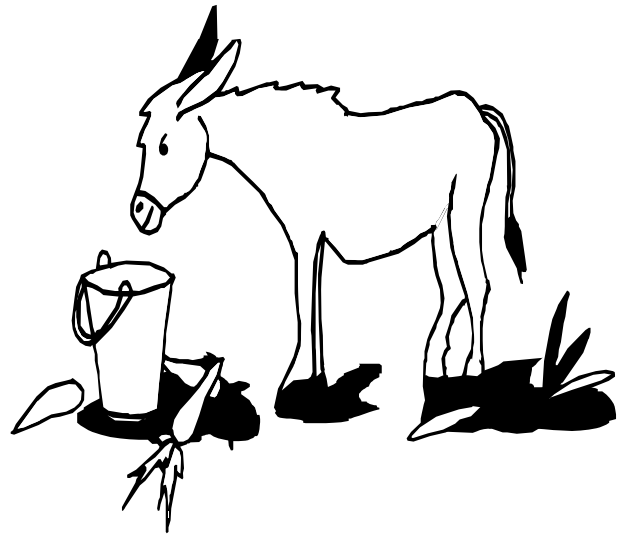

f u m e



"st"

Say, "s - t sounds like 'st'."

st ar



st op



st ep

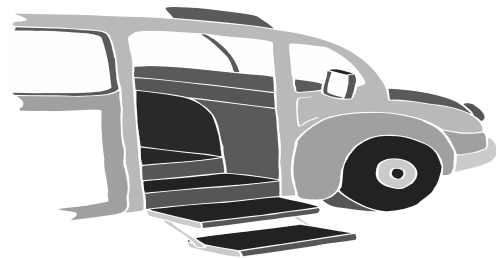

fast



s t a r

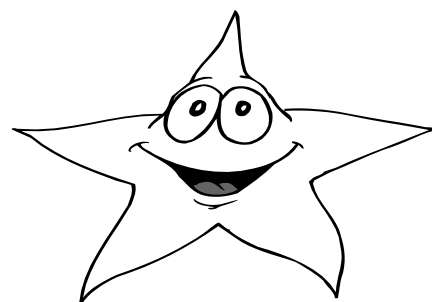

s t o p



s t e p

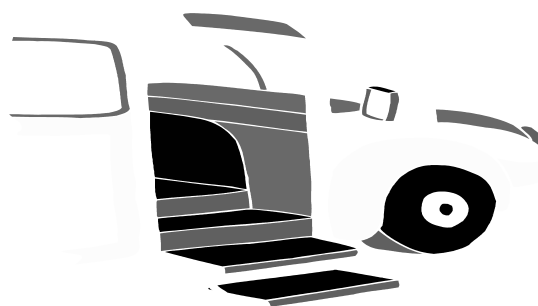

F a s t



"nd"

Say, "n - d sounds like 'nd'."

hand



sand



bend



wind



h a n d



s a n d

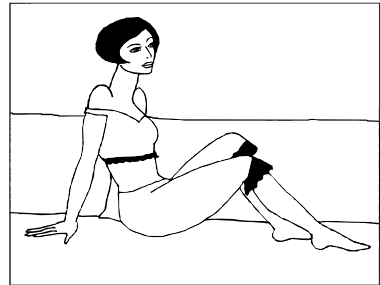

b e n d



w i n d

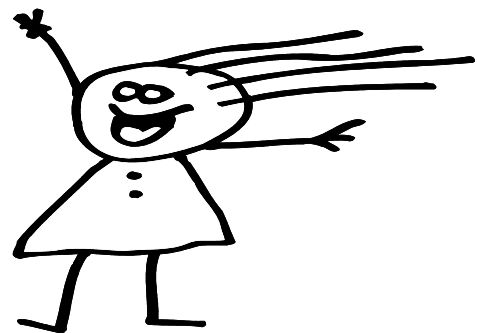

"wh"

Say, "Sometimes the 'h' is silent - after a 'w'."

whip

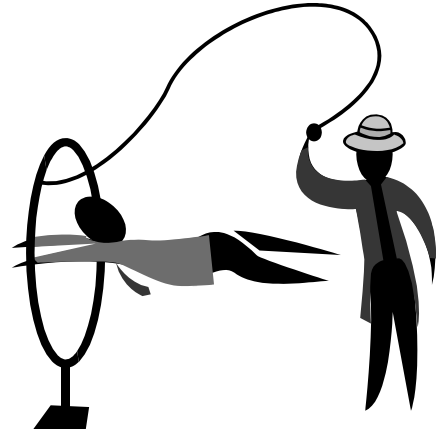

when

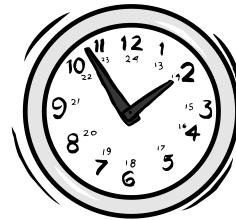

?

what

?

w h i p

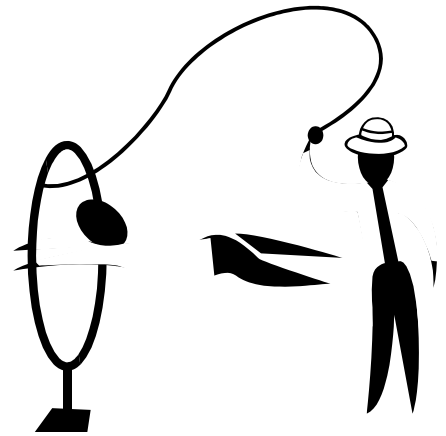

w h e n

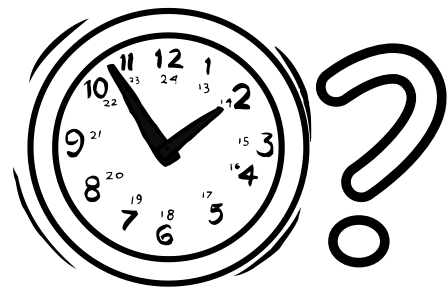

w h a t



"ck"

Say, "c - k sounds like 'kk'."

kick



sock



duck

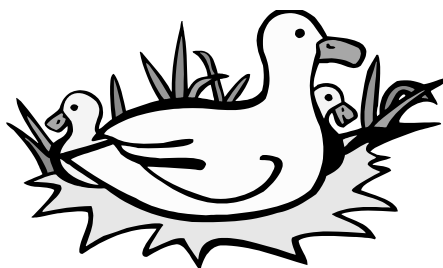

back



k i c k



s o c k



d u c k



b a c k

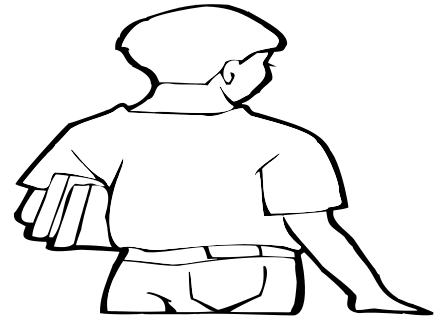

“ || ”

Say, "the second 'l' is silent."

hill

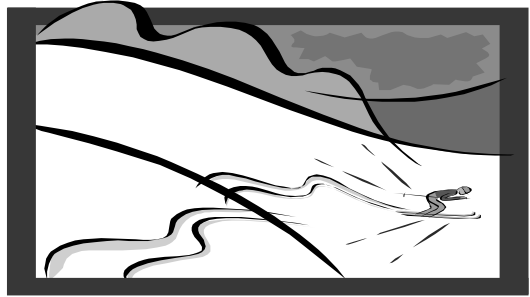

doll



bell

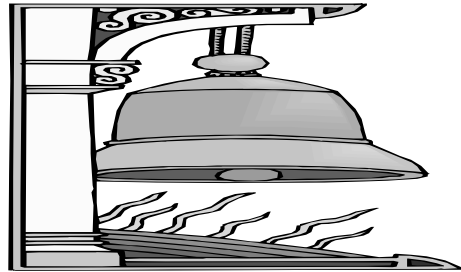

ball



hill

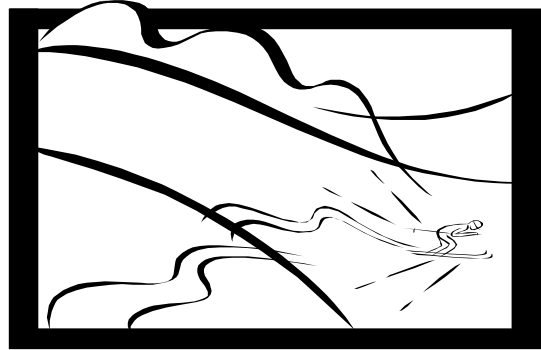

doll



bell

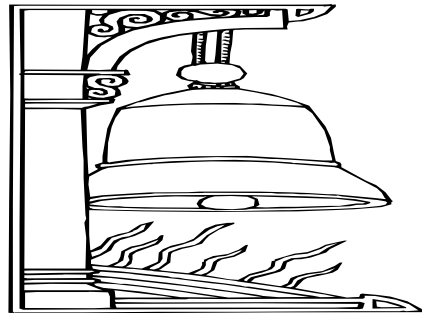

ball

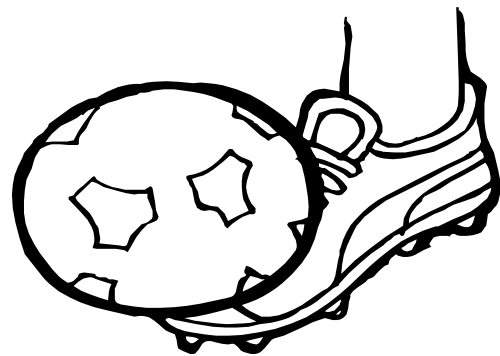

"sh"

Say, "s - h sounds like 'sh'."

ship

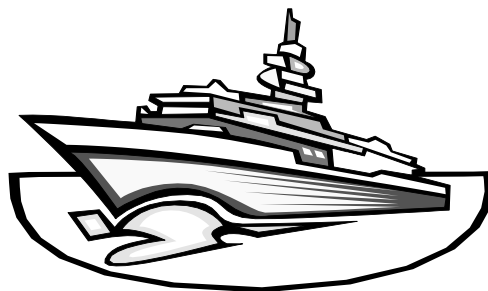

shop



shut

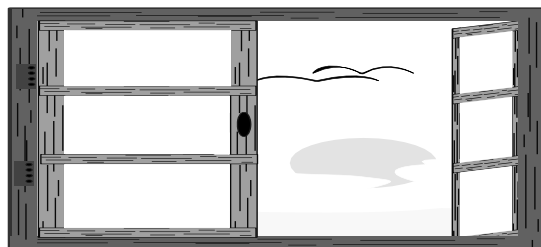

shed

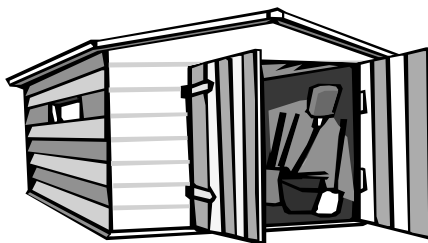

ship

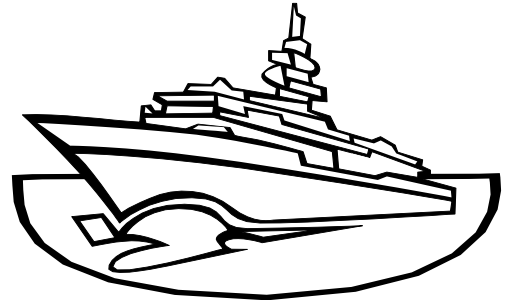

shop



shut

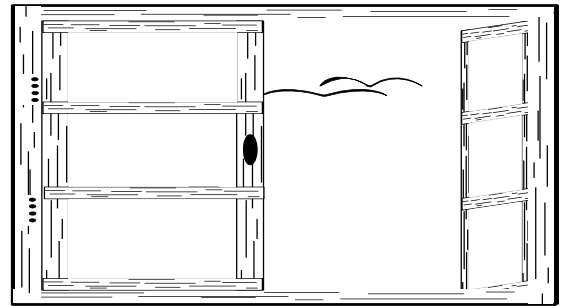

shed

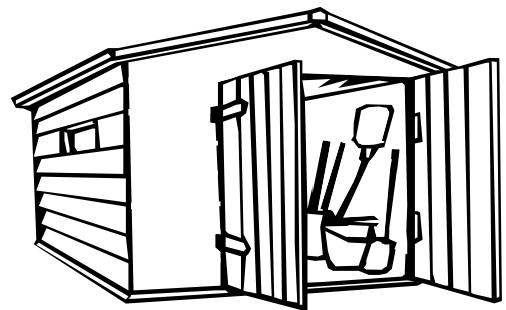

"ch"

Say, "c - h sounds like 'ch'."

chin



chat

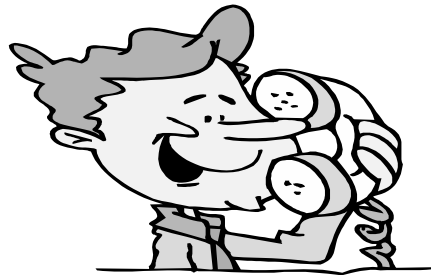

chew

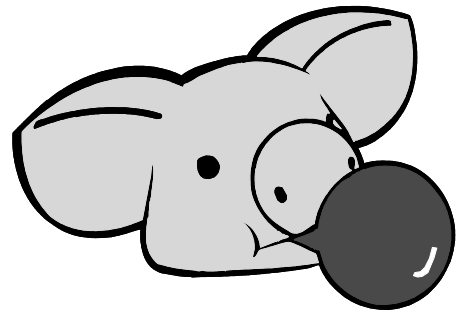

chick

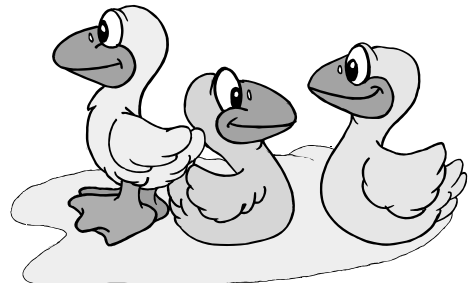

chin

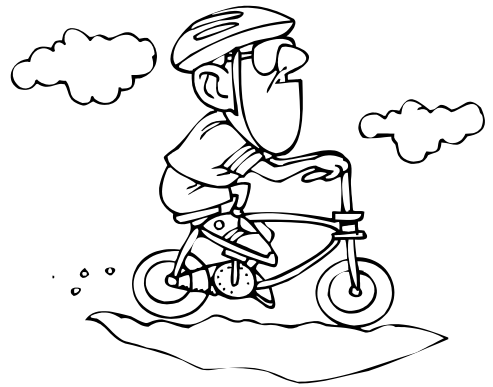

chat



chew

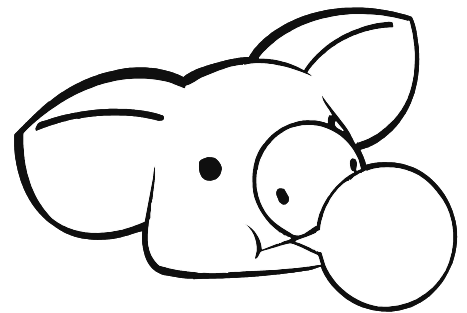

chick

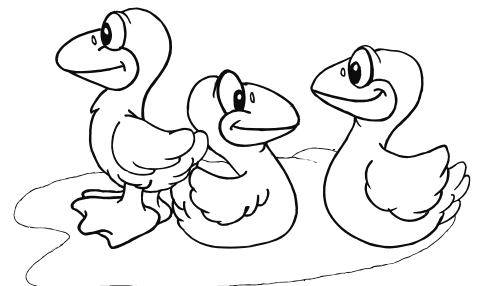

"th"

Say, "t - h sounds like 'th'."

thin



think



throw

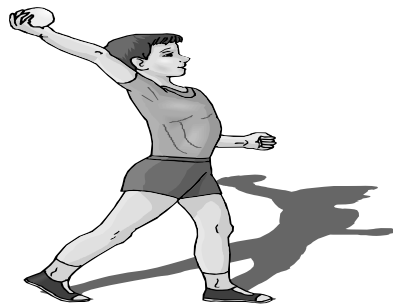

thorn

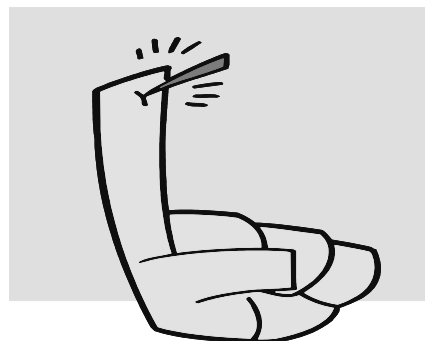

thin



think



throw

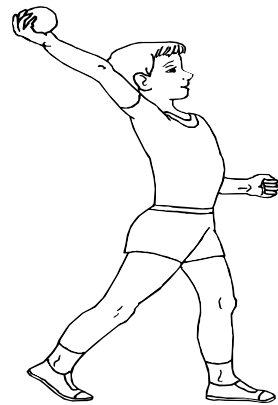

horn

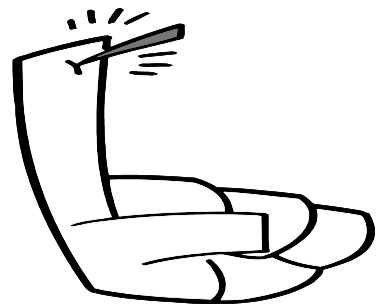

"ng"

Say, "n - g sounds like '-ng'."

ring

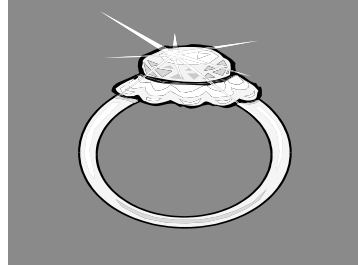

sing



king



hang

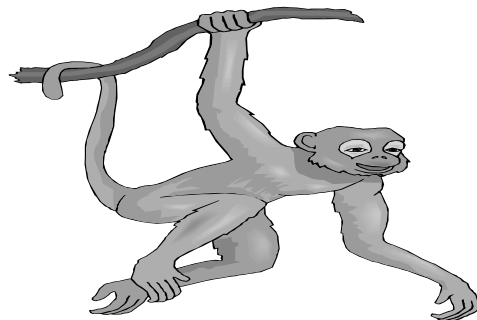

ring

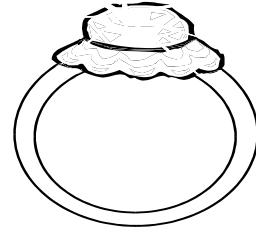

sing



king

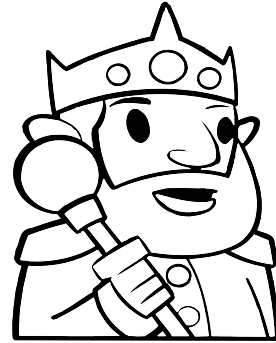

hang

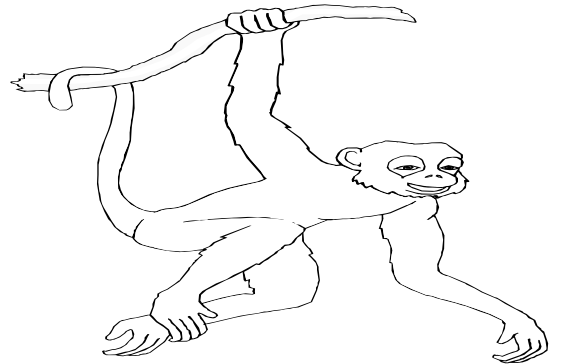

" o a "

Say, "The 'a' is silent and makes the 'o' say its name."

coat



boat



goat

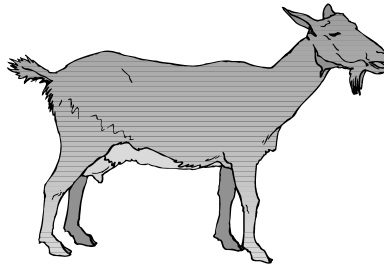

soap



c o a t



b o a t



g o a t

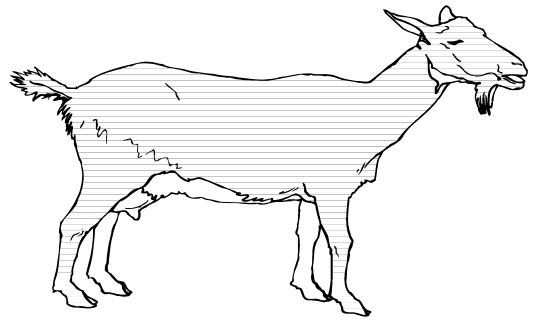

s o a p



"ee"

"The second 'e' is silent and makes the first say its name."

bee

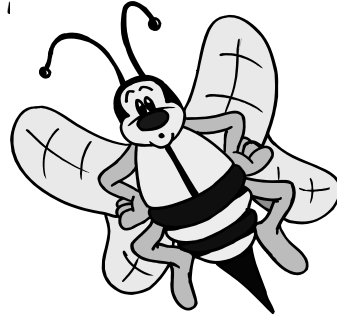

see

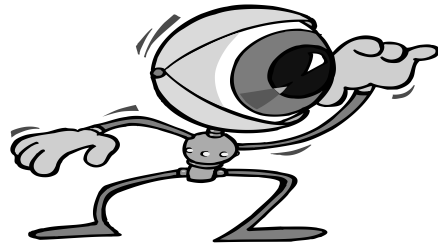

feed

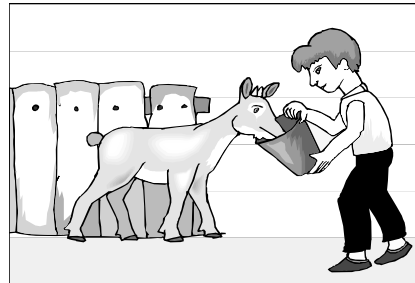

weed

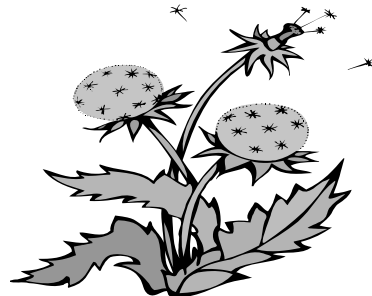

b e e

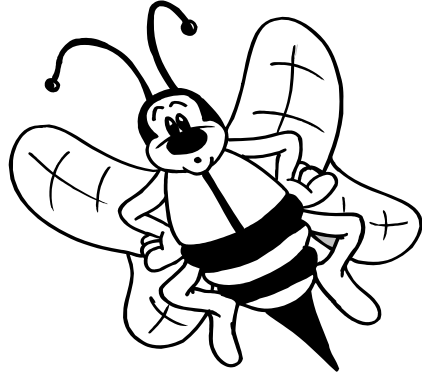

s e e

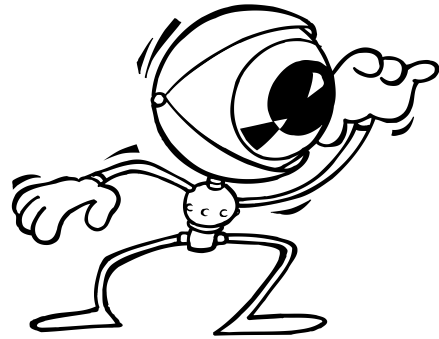

F e e d

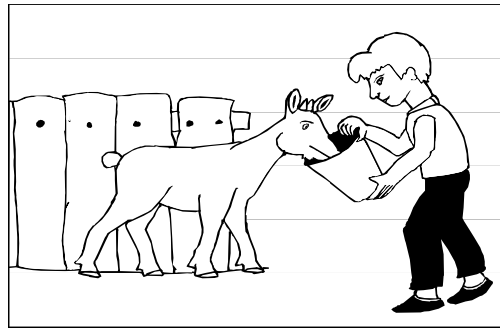

w e e d



"ea"

"The 'a' is silent and makes the 'e' say its name."

ear



hear

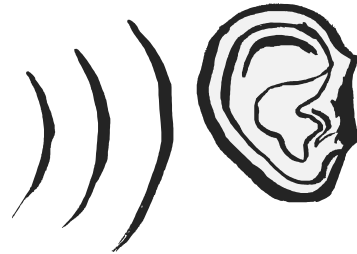

fear



gear

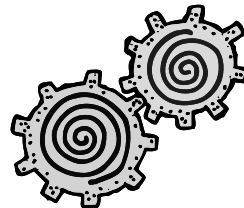

ear



hear

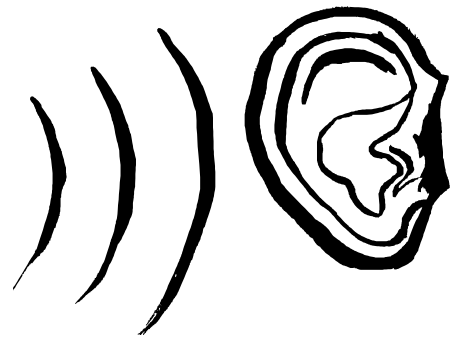

Fear



gear

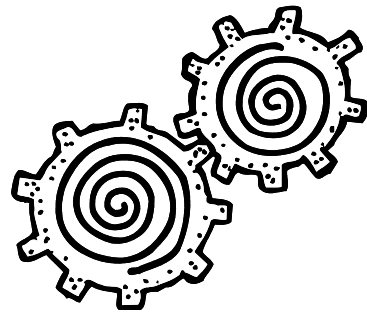

" o o "

Say, "o - o sounds like 'oo'."

book



hook

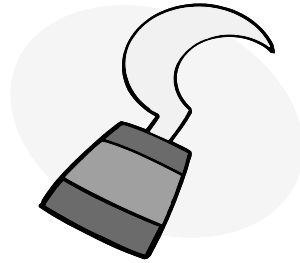

look

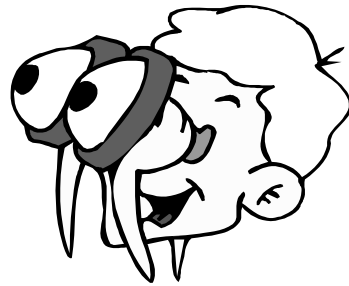

moon

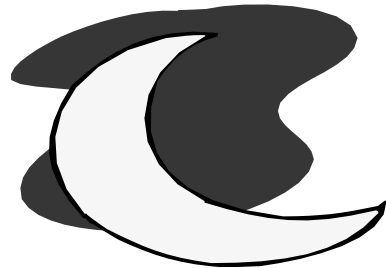

book



hook

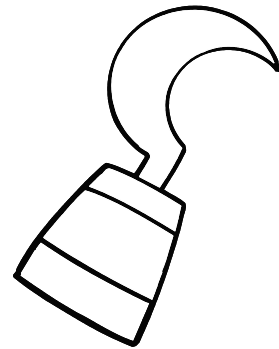

look



moon

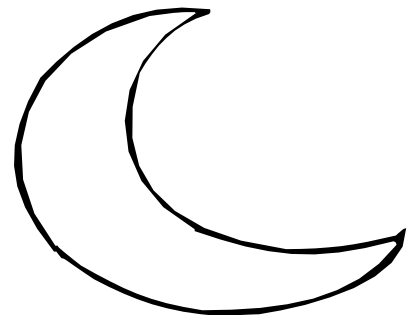

"oy"

Say, "o - y sounds like 'oi'."

toy



boy



joy



toy



boy



joy



"OW"

Say, "o - w sounds like 'ah-w'."

COW

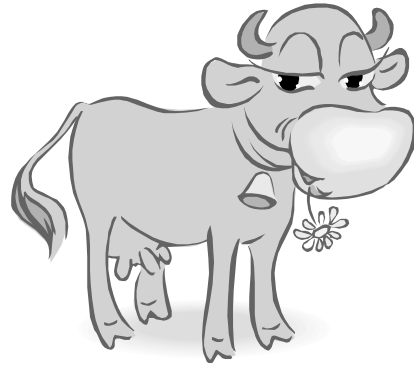

now

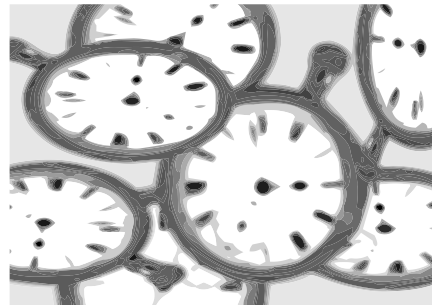

WOW

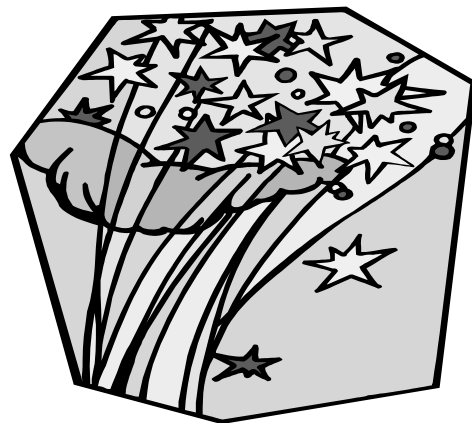

C O W

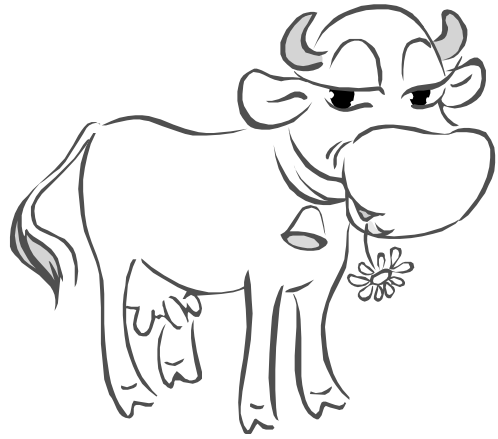

N O W

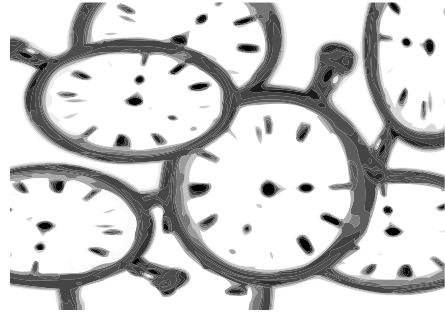

W O W

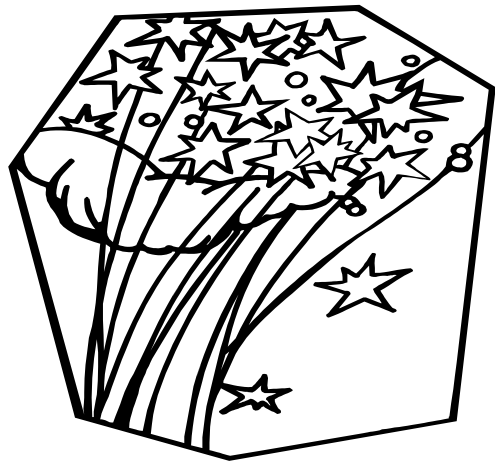

"ou"

Say, "o - u sounds like 'ah-w'."

mouth



house



mouse

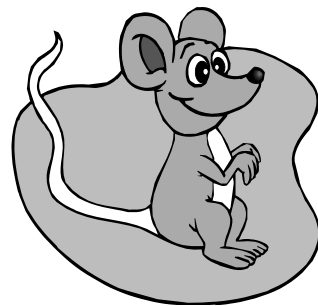

m o u t h



h o u s e



m o u s e

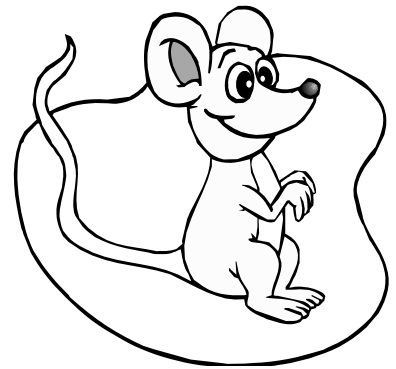

"aw"

Say, "a - w sounds like 'au'."

saw

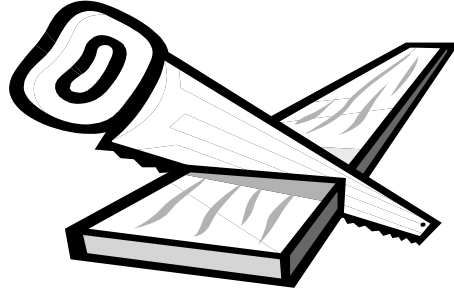

jaw

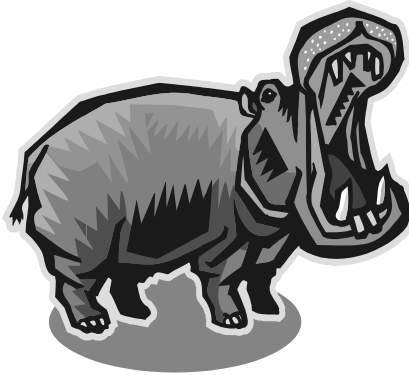

paw



draw



s a w

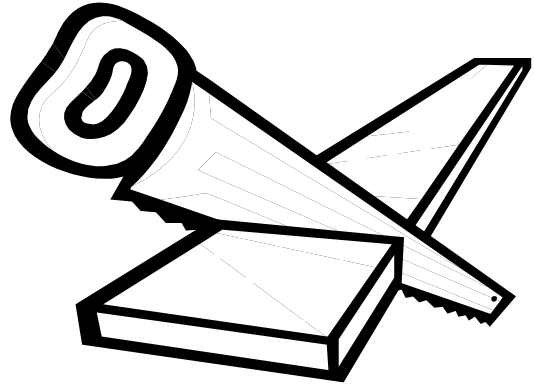

j a w

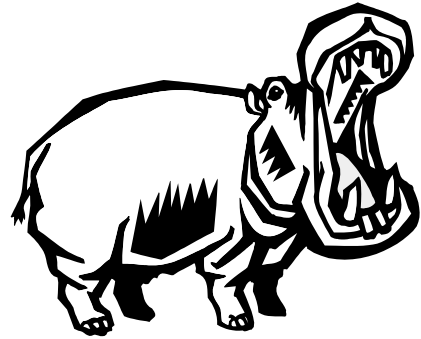

p a w



d r a w

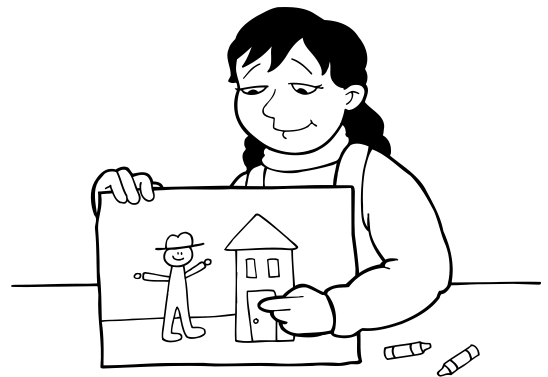

"ar"

Say, "a - r sounds like 'ar'."

car



jar



far

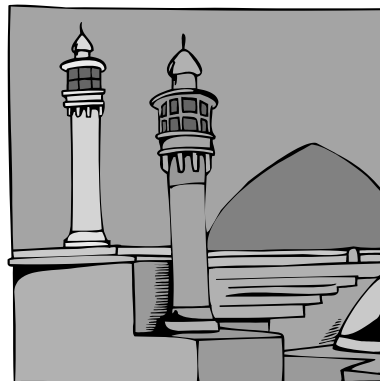

car

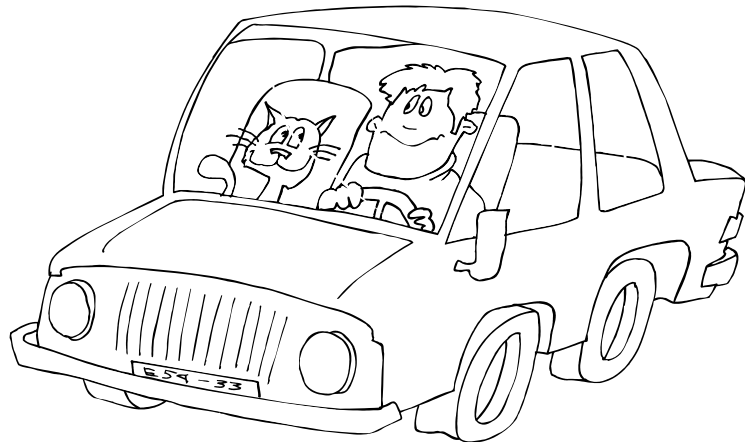

jar

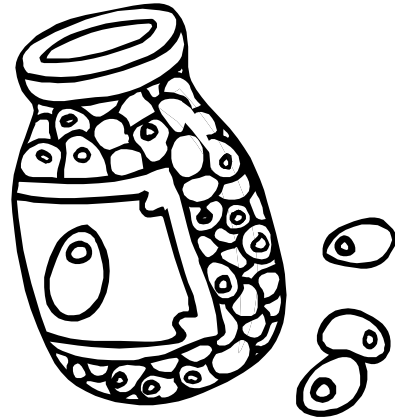

Far

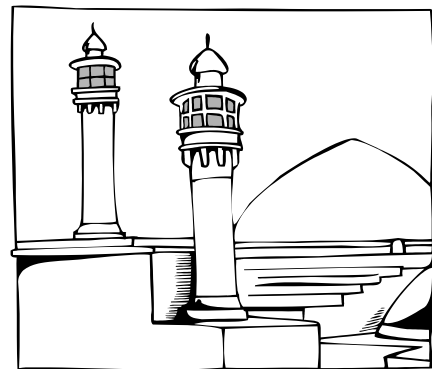

"er"

Say, "e - r sounds like 'er'."

her



over

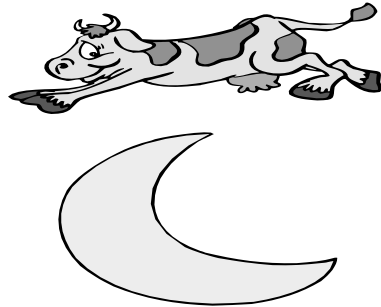

under

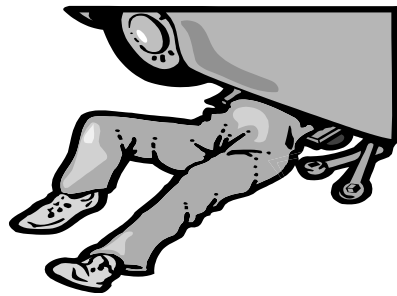

river



her



over

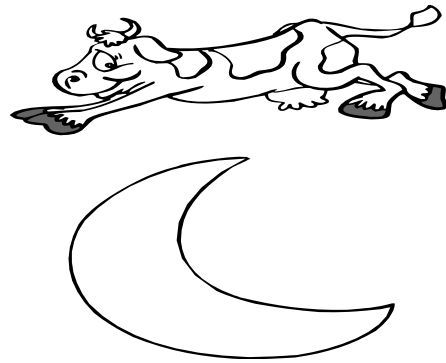

under

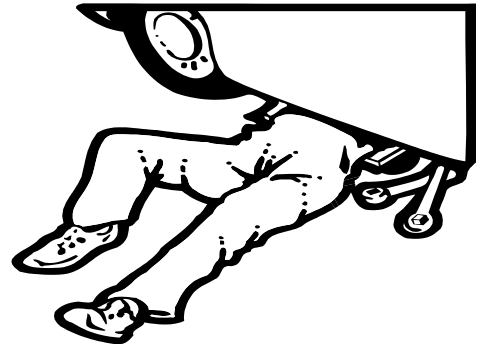

river

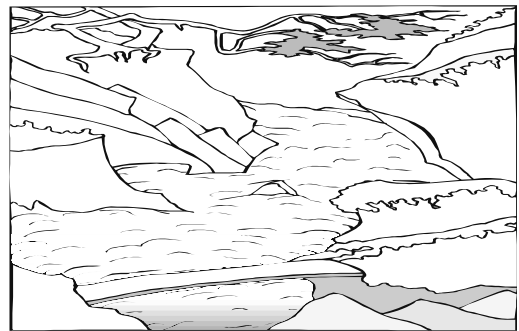

"or"

Say, "o - r sounds like 'or'."

door



floor



torn



door



Floor



torn

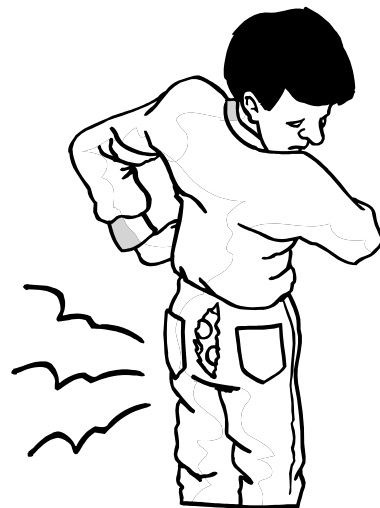

"ew"

Say, "e - w sounds like 'ew'."

chew



stew



new



chew



stew

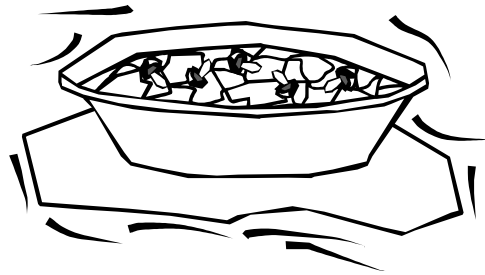

new



"ay"

Say, "the 'y' is silent and makes the 'a' say its name."

say



day



play

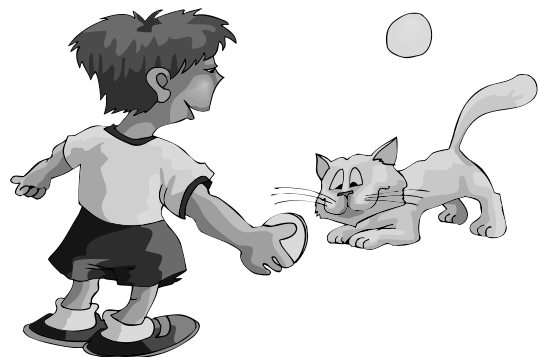

say



day



play

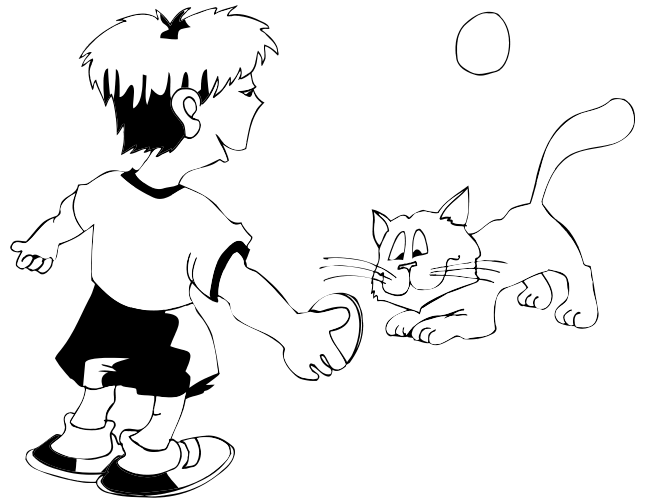

s o f t c = s

Say, "Sometimes 'c' sounds like 's'."

i c e

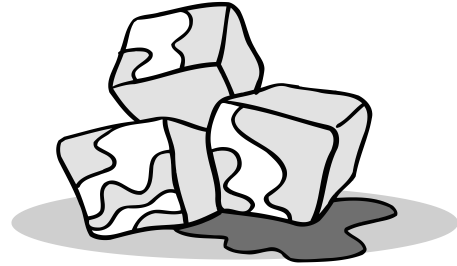

d i c e

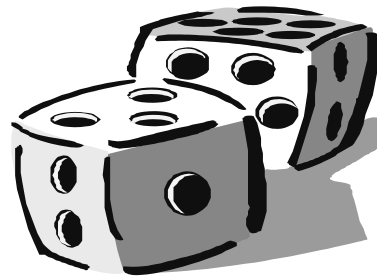

f a c e



r a c e



ice

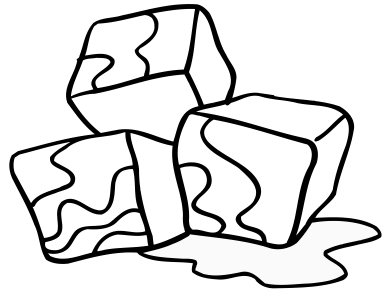

dice

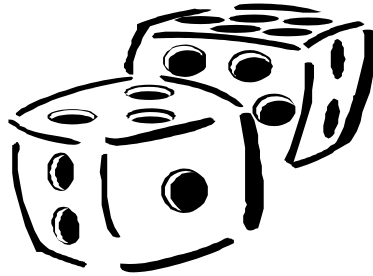

Face



race

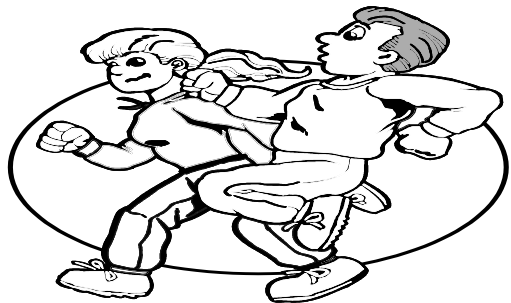

"qu"

Say, "q - u sounds like 'kw'."

quiz



quick



queen



quack



quiz

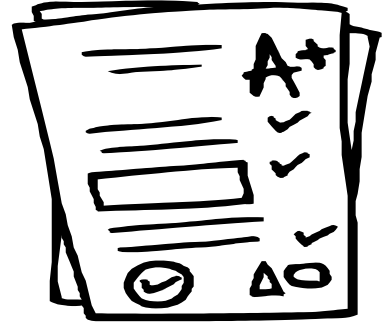

quick

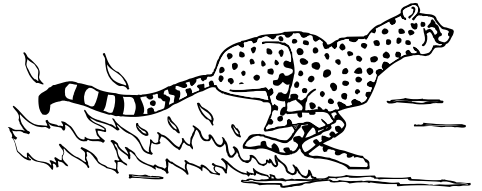

queen



quack



Sight Words

Say, "Some words don't follow all the rules."

is

[iz]

the

[-uh]

i s

t h e

Sight Words

Say, "Some words don't follow all the rules."

of [uh, v]

you [yu]

of

you

Sight Words

Say, "Some words don't follow all the rules."

t o [tu]

m y [mi]

t o

m y

Sight Words

Say, "Some words don't follow all the rules."

are R

do [du]

are

do

Sight Words

Say, "Some words don't follow all the rules."

she



does [duz]

she

does

punctuation

•

Adult says, "a period is for the end of a sentence."

,

Adult says, "a comma is used between items listed –
one, two."

?

Adult says, "a question mark is for questions –
example: do you understand?"

!

Adult says, "an exclamation point is for emphasis!"

Segmenting

Say, *"Let's practice breaking up big words."*
Have your student cover part of it - with some fingers!

r a b - b i t

r a b b i t

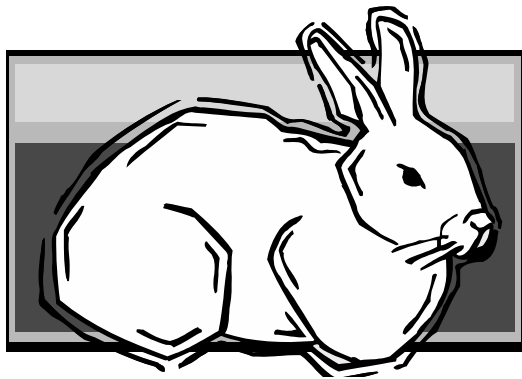

r a b - b i t

r a b b i t

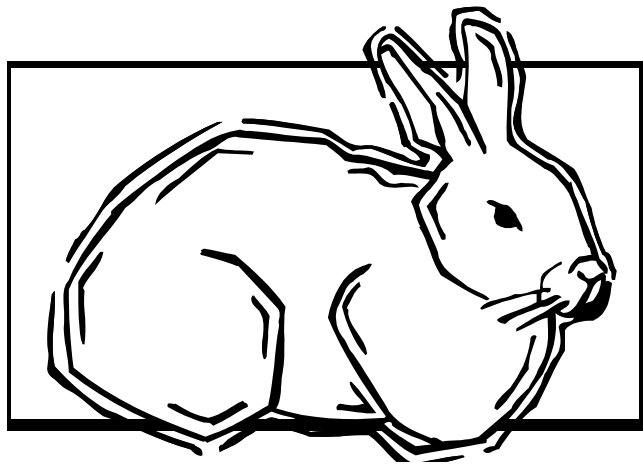

Segmenting

Say, *"Let's practice breaking up big words."*
Have your student cover part of it - with some fingers!

ti - ger

tiger



ti-ger

tiger

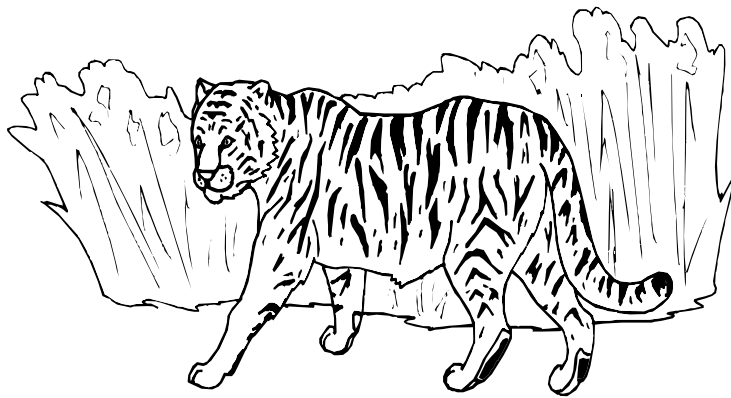

Segmenting

Say, *"Let's practice breaking up big words."*
Have your student cover part of it - with some fingers!

z e - b r a

z e b r a



ze-bra

zebra

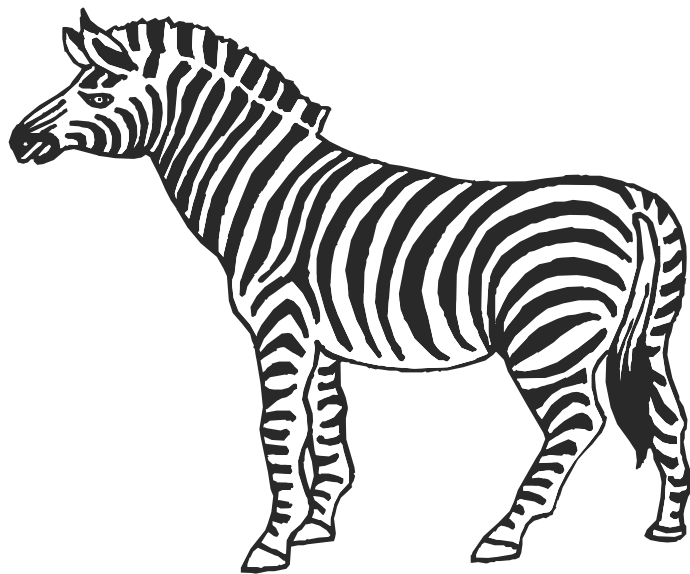

Segmenting

Say, *"Let's practice breaking up big words."*
Have your student cover part of it - with some fingers!

s n - a k e

s n a k e



s n - a k e

s n a k e

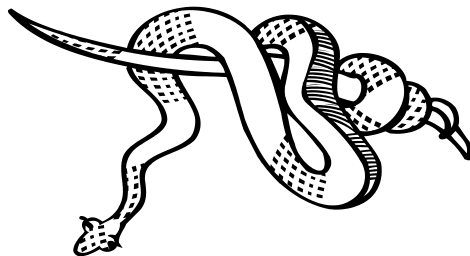

Segmenting

Say, *"Let's practice breaking up big words."*
Have your student cover part of it - with some fingers!

sh - ark

shark

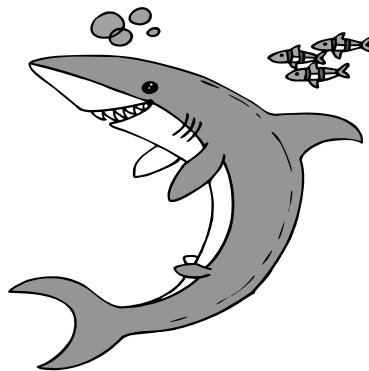

sh-ark

shark

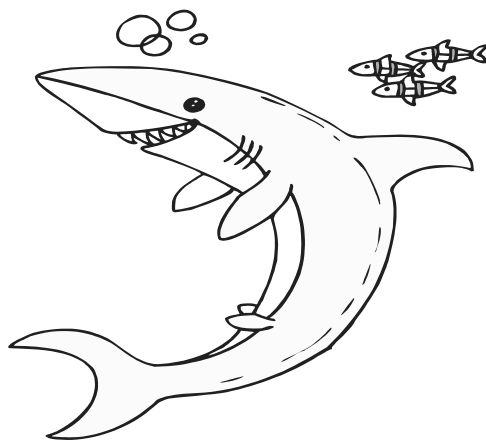

Segmenting

Say, *"Let's practice breaking up big words."*
Have your student cover part of it - with some fingers!

sk - unk

skunk



sk-unk

skunk



Segmenting

Say, *"Let's practice breaking up big words."*
Have your student cover part of it - with some fingers!

dra - gon

dragon



dra-gon

dragon





I see a tiger!

Appendix A: Alphabet Flash Cards

Notes

(1) You have express permission to photocopy these flash cards - on to card stock, or heavy duty construction paper. You may also want to laminate them, hole punch them and put them on a ring or two.

(2) The graphic art is left in gray scale by design. We have found that color distracts from the process.

A a

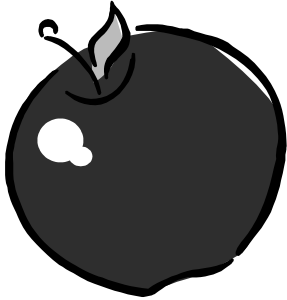

B b



C c

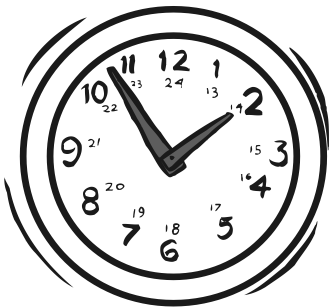

D d

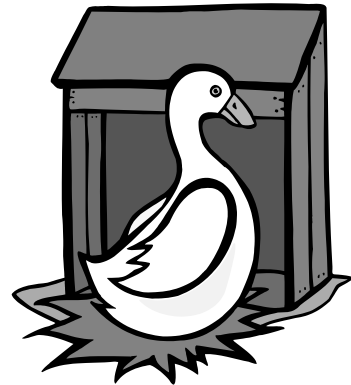

E e

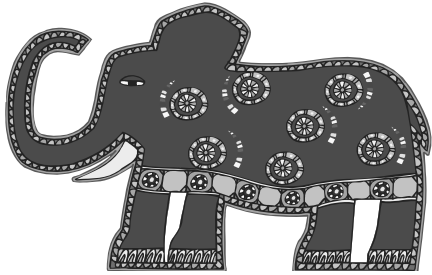

F f

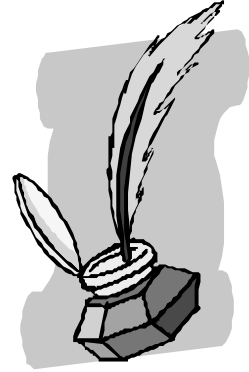

G g



H h



I i

J j

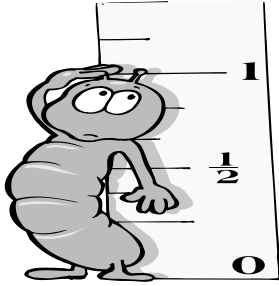

K k

L l

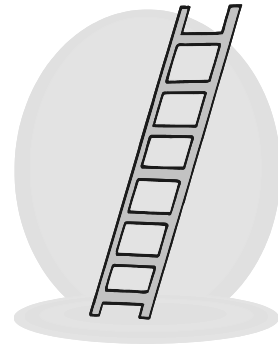
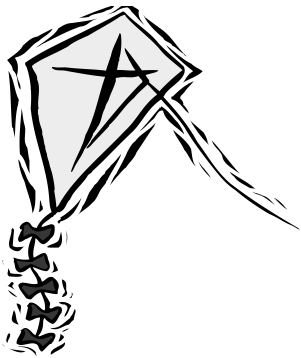

M m

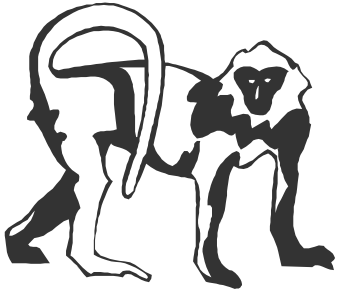

N n

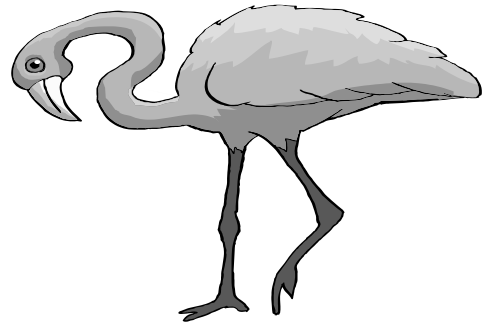

O o

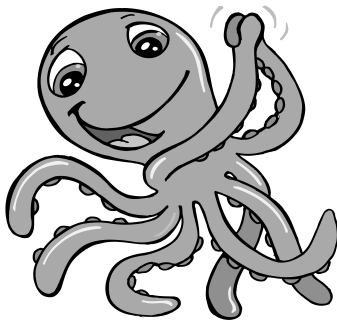

P p

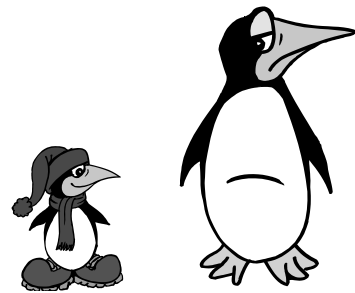

Q q



R r

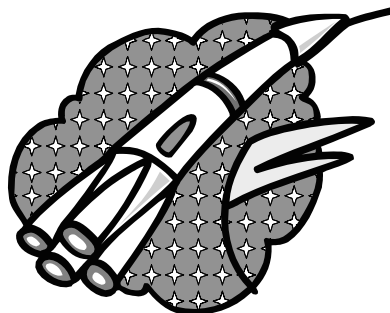

S s

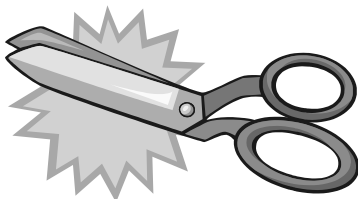

T t



U u

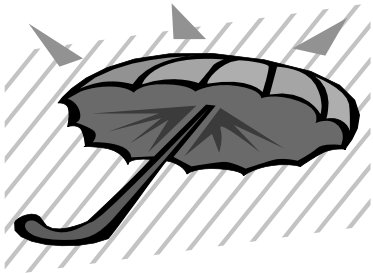

V v



W w

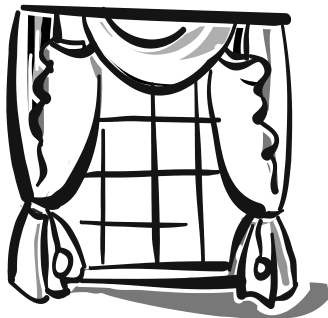

X x

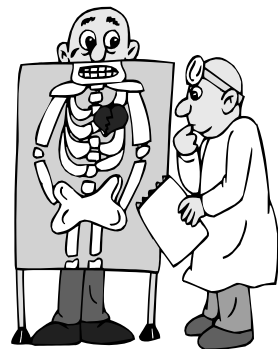





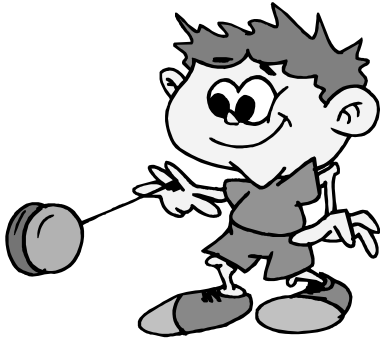



Y y

Z z











Appendix B: Any Trouble Remembering Letter Sounds?





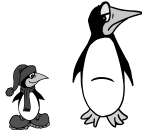

If they need a little extra help remembering a letter-sound, here is a list of the letters and possible devices to help them remember. So, when they see the letter, they should think of the picture and associate the first sound. After a couple of times reminding them of the picture-memory device, they should start to begin to remember the letter-sound independently.

<u>Letter</u>	<u>Picture</u>	<u>Device</u>
a		An /a/ is shaped like an apple.
b		See how her body, the string and balloon form the shape of a /b/.
c		A clock is round like a /c/.
d		The duck is shaped like a /d/.
e		The elephant's trunk is shaped like an /e/ and its legs like an /E/.
f		The feather is shaped like an /f/.
g		The goat's horns are shaped like a /g/ or /G/.
h		The house & chimney are shaped like an /h/.

Appendix B (continued)

<u>Letter</u>	<u>Picture</u>	<u>Device</u>
i		The inch-worm, with his body & head is shaped like a small /i/.
j		The jogger's body, with his leg extending back looks like a /j/.
k		The cross-bars of the kite look like a /k/.
l		A ladder is shaped like an /l/.
m		The monkey's legs are shaped like an /m/.
n		The crane's neck is shaped like an /n/ or /N/.
o		The octopus' head is round like an /o/.
p		The penguin, is shaped similarly to a /p/.
r		The rocket is shaped like an /r/.

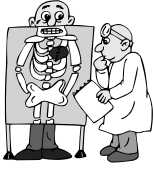
Appendix B (continued)

<u>Letter</u>	<u>Picture</u>	<u>Device</u>
s		The scissors' handles look like an /s/.
t		The table is shaped like a /t/.
u		The umbrella handle is shaped like a /u/.
v		The handle of the vacuum and the dust cloud form a /v/.
w		The drapes of the window form an upside-down /w/.
x		His hip bone looks like an /x/.
y		Think of a /y/ like throwing a yo-yo up and down.
z		The zebra's head & neck are shaped like a /z/.

Note: the 'q' is not here, because it is not in Section 1 - Letter Sounds. You can find the "qu" combination in Section 2 - Blends.

Appendix C - List of All English Language Sounds (aka: phonemes)

Consonant Phonemes

- 1 - /b/
- 2 - /k/
- 3 - /d/
- 4 - /f/
- 5 - /g/
- 6 - /h/
- 7 - /j/
- 8 - /l/
- 9 - /m/
- 10 - /n/
- 11 - /p/ *
- 12 - /r/
- 13 - /s/
- 14 - /t/
- 15 - /v/
- 16 - /w/
- 17 - /y/ *
- 18 - /z/

Consonant-Blend Phonemes

- 19 - /ch/
- 20 - /sh/
- 21 - /th/
- 22 - /ng/..... [ring, sing]
- 23 - /zh/**

Notes:

* Noticeably missing from the consonant phoneme list(s) are /q/ and /x/. That is because they do not have their own sounds per say, but are made up of the other sounds. For instance, /x/ is /eks/, and /q/ is /kw/ (as in "queen" and "quack").

** /zh/ is a more subtle sound found in "measure" and "treasure".

*** Some consider the /oo/ sound in "moon" and "spoon" to be a separate sound, when compared to "book" and "look".

Vowel Phonemes

- 24 - /a/ [short-a]
- 25 - /e/ [short-e]
- 26 - /i/ [short-i]
- 27 - /o/ [short-o]
- 28 - /u/ [short-u]
- 29 - /ā/ [long-a]
- 30 - /ē/ [long-e]
- 31 - /ī/ [long-i]
- 32 - /ō/ [long-o]
- 33 - /ū/ [long-u]
- 34 - /oo/..... [book, look, hook]***
- 35 - /oi//oy/.. [oil, soil, boil, toy, boy]
- 36 - /ou//ow/. [house, mouse, cow]
- 37 - /au//aw/. [taught, caught, saw, law]

Vowel-Consonant Blended Phonemes

- 38 - /ar/..... [car, cart, bark, dark]
- 39 - /er/..... [her, sir, fur, sister]
- 40 - /or/..... [torn, born, warn, door]
- 41 - /ew/..... [chew, stew]

Reference: National Reading Panel, via the National Institute of Health (NIH) & the National Institute of Child Health & Human Development (NICHD): <https://www.nichd.nih.gov/research/supported/Pages/nrp.aspx/>. Note: phoneme lists may vary slightly from 41 to 44 phonemes, depending on who you ask.

INDEX

Quick Start Instructions	3	
Dear Parent	8	
SECTION 1: SHORT-VOWEL BOOK SKILLS		
a - letter-sound	9	Lesson 1
b - letter-sound	11	Lesson 2
c - letter-sound	19	Lesson 6
d - letter-sound	127	Lesson 60
e - letter-sound	41	Lesson 17
f - letter-sound	131	Lesson 62
g - letter-sound	107	Lesson 50
h - letter-sound	23	Lesson 8
i - letter-sound	61	Lesson 27
j - letter-sound	145	Lesson 69
k - letter-sound	149	Lesson 71
l - letter-sound	161	Lesson 77
m - letter-sound	33	Lesson 13
n - letter-sound	45	Lesson 19
o - letter-sound	79	Lesson 36
p - letter-sound	43	Lesson 18
r - letter-sound	155	Lesson 74
s - letter-sound	29	Lesson 11
t - letter-sound	13	Lesson 3
u - letter-sound	97	Lesson 45
v - letter-sound	137	Lesson 65
w - letter-sound	69	Lesson 31
x - letter-sound	115	Lesson 54
y - letter-sound	165	Lesson 79
z - letter-sound	171	Lesson 82
/a-x/, "ax" reading page	117	Lesson 55
/b-a-t/, "bat" reading page	17	Lesson 5
/b-i-n/, "bin" reading page	73	Lesson 33
/c-a-t/, "cat" reading page	21	Lesson 7
/c-u-p/, "cup" reading page	101	Lesson 47
/d-a-d/, "dad" reading page	129	Lesson 61
/f-a-n/, "fan" reading page	135	Lesson 64
/g-u-m/, "gum" reading page	109	Lesson 51
/h-a-t/, "hat" reading page	27	Lesson 10
/h-e-n/, "hen" reading page	55	Lesson 24
/h-o-p/, "hop" reading page	87	Lesson 40
/i-n/, "in" reading page	63	Lesson 28
/j-e-t/, "jet" reading page	147	Lesson 70
/k-i-t/, "kit" reading page	153	Lesson 73
/l-i-d/, "lid" reading page	163	Lesson 78
/m-a-t/, "mat" reading page	35	Lesson 14
/m-e-n/, "men" reading page	53	Lesson 23
/m-o-m/, "mom" reading page	83	Lesson 38
/m-o-p/, "mop" reading page	89	Lesson 41
/o-n/, "on" reading page	81	Lesson 37
/o-x/, "ox" reading page	123	Lesson 58

INDEX (continued)

/p-e-n/, "pen" reading page	49	Lesson 21
/p-i-n/, "pin" reading page	65	Lesson 29
/p-o-p/, "pop" reading page	91	Lesson 42
/p-u-p/, "pup" reading page	105	Lesson 49
/r-u-n/, "run" reading page	157	Lesson 75
/s-a-t/, "sat" reading page	31	Lesson 12
/t-e-n/, "ten" reading page	51	Lesson 22
/u-p/, "up" reading page	99	Lesson 46
/v-a-n/, "van" reading page	139	Lesson 66
/w-i-n/, "win" reading page	71	Lesson 32
/y-e-s/, "yes" reading page	169	Lesson 81
/z-i-p/, "zip" reading page	173	Lesson 83
b, a, t, /b-a-t/ review & reading page	15	Lesson 4
c, /c-a-t/, h, /h-a-t/ review & reading page	25	Lesson 9
d, /d-a-d/, f review & reading page	133	Lesson 63
/f-a-n/, v, /v-a-n/ reading & review page	141	Lesson 67
/h-o-p/, /m-o-p/, /p-o-p/ reading review page	93	Lesson 43
i, /i-n/, /p-i-n/ review & reading page	67	Lesson 30
j, /j-e-t/, k review & reading page	151	Lesson 72
/k-i-t/, r, /r-u-n/ reading & review page	159	Lesson 76
l, /l-i-d/, y review & reading page	167	Lesson 80
/m-e-n/, /t-e-n/, /h-e-n/ reading review page	57	Lesson 25
o, /o-n/, /m-o-m/ review & reading page	85	Lesson 39
p, e, n, /p-e-n/ review & reading page	47	Lesson 20
/p-u-p/, g, /g-u-m/ reading & review page	111	Lesson 52
s, /s-a-t/, m, /m-a-t/ review & reading page	37	Lesson 15
u, /u-p/, /c-u-p/ review & reading page	103	Lesson 48
w, /w-i-n/, /b-i-n/ review & reading page	75	Lesson 34
x, /a-x/, /o-x/ review & reading page	125	Lesson 59
/y-e-s/, z, /z-i-p/ reading & review page	175	Lesson 84
phrase reading page ("sit on mat")	119	Lesson 56
phrase reading page ("pin hat on mom")	121	Lesson 57
short vowel /a/, review / assessment page	39	Lesson 16
short vowel /e/, review / assessment page	59	Lesson 26
short vowel /i/, review / assessment page	77	Lesson 35
short vowel /o/, review / assessment page	95	Lesson 44
short vowel /u/, review / assessment page	113	Lesson 53
chapter 6, review / assessment page	143	Lesson 68
chapter 7, review / assessment page	177	Lesson 85
<i>Congratulations – You Can Read Short-Vowel Books!</i>	179	

SECTION 2: LONG VOWELS & BLENDS

Long Vowel /a/ Lesson	181
Long Vowel /i/ Lesson	183
Long Vowel /o/ Lesson	185
Long Vowel /u/ Lesson	187

INDEX (continued)

SECTION 2: LONG VOWELS & BLENDS (cont.)

/ar/ Blend Lesson	223
/aw/ Blend Lesson	221
/ay/ Blend Lesson	231
/ch/ Blend Lesson	201
/ck/ Blend Lesson	195
/ea/ Vowel Team Lesson.....	211
/ee/ Vowel Team Lesson.....	209
/er/ Blend Lesson	225
/ew/ Blend Lesson	229
/ll/ Blend Lesson	197
/ng/ Blend Lesson	205
/nd/ Blend Lesson	191
/oa/ Vowel Team Lesson.....	207
/oo/ Vowel Team Lesson.....	213
/or/ Blend Lesson	227
/ou/ Blend Lesson	219
/ow/ Blend Lesson	217
/oy/ Blend Lesson	215
/qu/ Blend Lesson	235
/sh/ Blend Lesson	199
soft-c Blend Lesson	233
/st/ Blend Lesson	189
/th/ Blend Lesson	203
/wh/ Blend Lesson	193
"are" & "do" Sight Words Lesson	243
"is" & "the" Sight Words Lesson	237
"of" & "you" Sight Words Lesson	239
"she" & "does" Sight Words Lesson	245
"to" & "my" Sight Words Lesson	241
Punctuation Lesson	247
"dra-gon" Segmenting Lesson.....	260
"rab-bit" Segmenting Lesson.....	248
"sh-ark" Segmenting Lesson.....	256
"sk-unk" Segmenting Lesson.....	258
"sn-ake" Segmenting Lesson.....	254
"ti-ger" Segmenting Lesson.....	250
"ze-bra" Segmenting Lesson.....	252
Sentence reading page ("I see a tiger!")	262
Appendix A: Alphabet Flash Cards	263
Appendix B: Any Trouble Remembering Letter-Sounds?.....	271
Appendix C: List of All English Language Sounds	274//

Den's Reading Program - Local & Correspondence Testimonials

"You should publish it!"

-K.K., Parent of a Kindergartner

"It's great!"

-C.C., Parent of a Kindergartner

"Hannah already can't put it down!"

-M.B., Parent of a Kindergartner

"Andrew is having a ball! He takes it to bed with him."

-J.H., Grandparent of a Four-Year Old

"That book is so very cute."

-S.W., Parent of a Kindergartner

"Thank you for such a great resource!"

-K.B., Kindergarten Teacher

"The pictures are gorgeous. This is great..!"

-W.G., Certified Reading Specialist

"He loves it! He just picked it up. He loves it."

-J.B., Mother of a 4 & 1/2 Year Old

"The program utilizes 80% or more of current research-based practices.

The sequence of the materials was good. The book would have a specific purpose for beginning kindergarten. This is well done..."

-Utah State Textbook Adoption Committee

"It is a great book and Nyah already loves reading out of it..."

-J.V., Parent of a Preschooler

"I've looked it over (and my first thought was how well put together the book is)..."

-P.W., Aunt of a Preschooler

"I think it's a great start for any pre-school, kindergarten or first-grade child..."

-M.H., Reading Teacher for over 25 Years

-more-

The Alphabet Book

www.TheAlphabetBook.com*

Pre-Phonics For Preschoolers

www.Pre-PhonicsForPreschoolers.com*

My Child's First Reading Book

www.MyChildsFirstReadingBook.com

First Reading Book

www.FirstReadingBook.com

The Phonics Reading Book

www.PhonicsReadingBook.com

Alphabet to Phonics

www.AlphabetToPhonics.com

*combined website: TAB forwards to PfP.com