

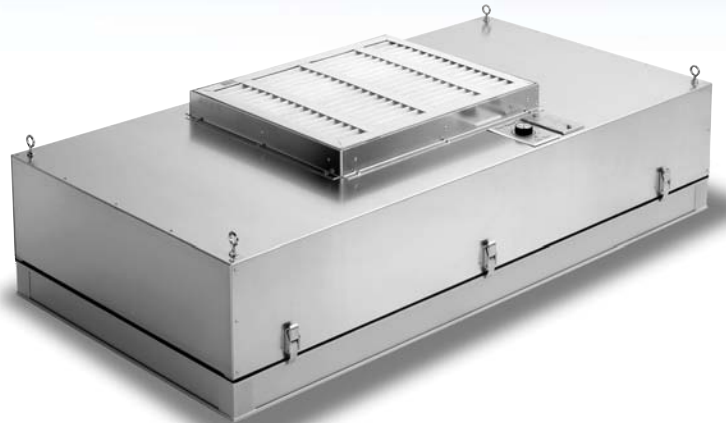

Better Air is Our Business®

AmericanAirFilter® **FM2-LE**

**Self-Contained Energy
Efficient Fan/Filter Modules
for Cleanroom Applications**



The FM2-LE is a self-contained fan/HEPA filter module for cleanroom applications. It can be used to upgrade existing cleanrooms or to convert existing space into a cleanroom without additional ductwork or air handling equipment. The modules can be used in most conventional ceiling grids or may be suspended independently. FM2-LE modules are available in 2' x 2', 2' x 3', and 2' x 4' sizes.

Energy Efficient

FM2-LE modules are energy efficient. Each module utilizes a rugged AC motorized impeller rated at 2.4 amps at start up and approximately 2 amps while in operation. The aluminum backward curved impeller is lightweight and has a long service life. All motors are dynamically balanced and 100% quality inspected.

Standard Features

- Extruded aluminum filter cell sides
- AstroCel® II HEPA filter, 99.99% efficient on 0.3 micrometer particles, 2"-deep minipleat media pack. HEPA meets UL 586 and UL 900
- White expanded metal faceguard on the downstream side of the filter
- 16-gauge mill finish aluminum pressure housing with 4 support points for hanging
- 115V, 60Hz, single-phase, energy efficient, backward curved motorized impeller wired junction box
- Variable speed control
- All electrical components UL Classified
- PerfectPleat® M8 1"-deep prefilter with DuraFlex® media, MERV 8

Options

- Duct connection (10" or 12" diameter) in lieu of prefilter
- Power cord
- Center divider with test port in filter
- ULPA filter, 99.9995% efficient on 0.1 - 0.2 micrometer particles, scanned
- 3" or 4" deep HEPA or ULPA filter
- Knife-edge filters for gel grid systems
- 230-volt, 60-Hz motor
- Stainless steel faceguard



Latches seal and hold the AstroCel® filter securely to the module.

FM2-LE Fan/Filter Module

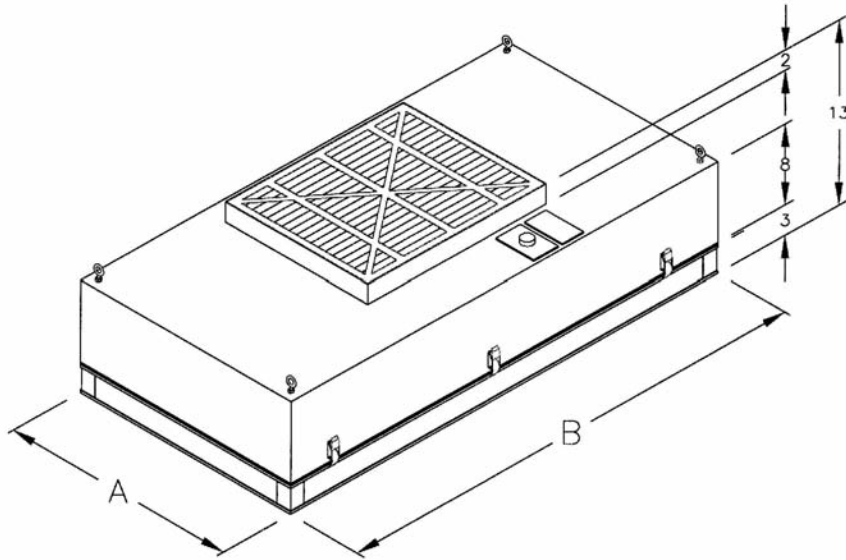

Product Information

Part Number	Dimensions (inches)		Unit Installed Weight (lbs.)	Unit Shipping Weight (lbs.)
	A	B		
3010352-002	23 ⁵ / ₈	23 ⁵ / ₈	26	30
3010345-002	23 ⁵ / ₈	35 ⁵ / ₈	40	50
3010337-002	23 ⁵ / ₈	47 ⁵ / ₈	53	60



® 10300 Ormsby Park Place Suite 600
Louisville, Kentucky 40223-6169

www.aafintl.com
Customer Service 888.AAF.2003
Fax 888.223.6500



AAF has a policy of continuous product research and improvement and reserves the right to change design and specifications without notice.

ISO Certified 9001:2000

© 2010AAF International

The USGBC Member logo is a trademark owned by the U.S. Green Building Council and is used by permission.