



CAUTION: CAREFULLY READ INSTRUCTIONS BEFORE PROCEEDING

OVERVIEW

WEGO Tach Adapter P/N 115005 is required when connecting WEGO units with data logging to capacitive discharge (CD) ignitions found on many Japanese motorcycles and small engines with flywheel triggered systems. An alternate tach adapter, P/N 115014 may be required with some inductive ignition systems.

IDENTIFYING IGNITION TYPE AND COIL CONNECTIONS

Refer to the vehicle or engine service manual for wiring diagram. In most cases the ignition coil will have two primary terminals. One terminal will be connected to the ignition module or ECM (engine control module). If the second coil terminal is connected to ground, a CD type ignition is present and P/N 115005 tach adapter will be required. If the second coil terminal is connected to switched +12 volt power, an inductive type ignition is present.

If you do not have a wiring diagram, you can use a DVM to check and identify the coil wiring.

Disconnect the coil primary connections. Turn the ignition switch on. If you measure +12 volts at one of the coil connections, you have an inductive type ignition.

If you have a CD type ignition, measure resistance from coil connections to ground (ignition switch off) to identify the ground wire. The other coil primary connection should go back to the ignition module or ECM and will be used to trigger the tach adapter.

NOTE: If you are not certain what type of ignition system is present, you can go ahead and try connecting the tach adapter. The tach adapter will not be damaged by being connected to the wrong type of ignition system.

INSTALLATION

1. Mount the tach adapter near the WEGO unit using tie wraps or Velcro strips. To avoid water intrusion, mount the tach adapter with the wire exit oriented down.
2. Refer to Figure 1 or 2. Connect the brown wire from the tach adapter to the tach input (brown wire) on the WEGO unit.
3. Connect the black wire from the tach adapter to frame ground using the supplied ring tongue terminal. Use the same connection point that you used for the WEGO signal ground.
4. Connect the purple or white wire from the tach adapter to the active ignition coil terminal that is connected back to the ignition module or ECM. Due to the high voltage levels at this point, we suggest that you solder the connection and cover it with electrical tape or melt-liner type heat shrink tubing.

Figure 1 – P/N 115005 Tach Adapter Hookup for CD Ignition

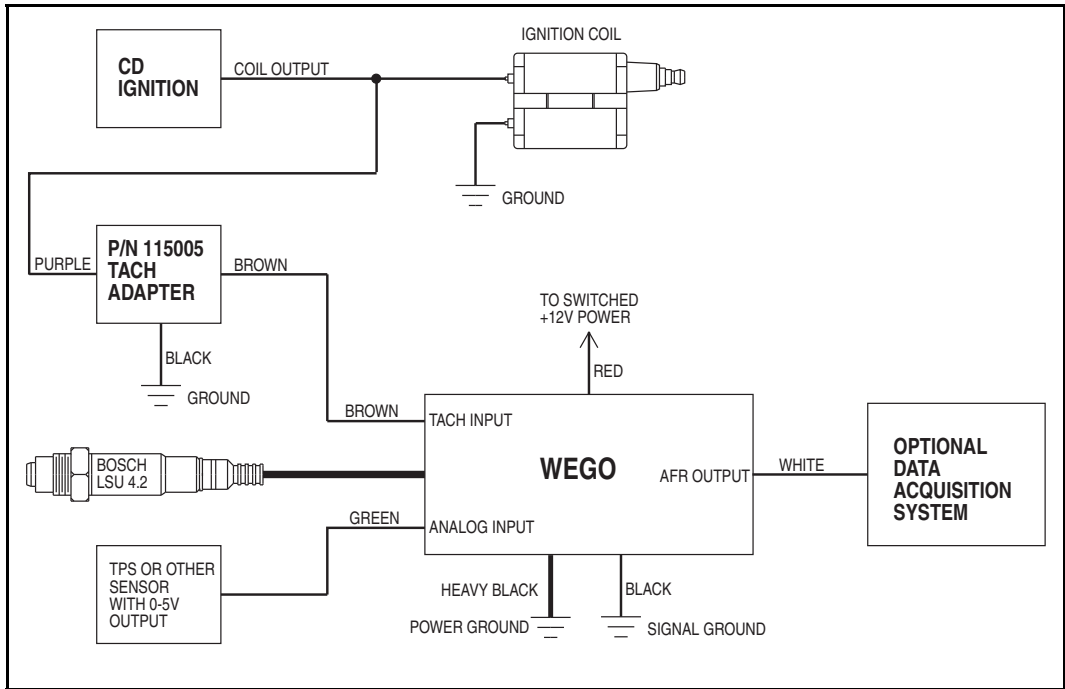

Figure 2 – P/N 115014 Tach Adapter Hookup for Inductive Ignition

