

# G Series

## General Purpose Shredder

- Low speed, high torque geared drive
- Powerful hydraulic swing type pusher (ram)
- Proven well engineered design
- Smaller footprint compared to traditional horizontal pusher style shredders
- Bolt-in drive shafts
- Multiple rotor designs and materials
- Two speed hydraulic system as standard

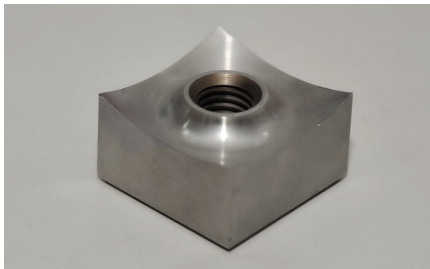

The shredders use concave ground square knives, producing high quality output. The cutters can be turned after a side is worn out.

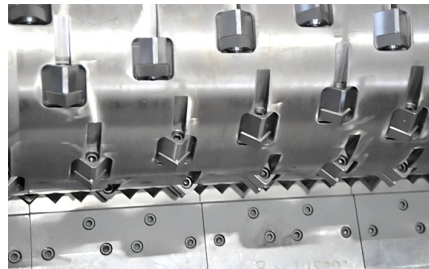

All Virtus shredders are equipped with a large diameter flat rotor. The knives are fixed in special knife holders fitted in machined pockets. Optional weld on hard facing is available for abrasive applications.



The G series shredders benefit from sturdy ram construction incorporating heavy duty guide bearings and universal couplings for reliable operation.

### General Description

The G shredders are single shaft shredders with a powerful two speed swing ram design eliminating the risk of blocking and wearing out of internal guide rails. The machine is very versatile and can be used for shredding of all kinds of input materials and is well suited for different industries. The 457 mm diameter rotors ranging from 850mm to 2000 mm width are driven by either one or two oversized gearboxes. The hydraulic power pack is well integrated into the machine housing to save space and protect it from damage but is still easy to access or remove for maintenance. The standard E rotor features the proven Virtus knife and knife holder design, as well as outboard bearings and a hydraulically operated screen cradle. The machines can be tailored to various applications and is offered with rotor cooling, hard facing, and other wear options.

### Applications

The G shredders have been designed for a wide range of applications and industries such as in-house and general recycling, electronic waste, and post consumer waste handling. Input materials can be all types and forms of plastics such as lumps, pipes, film, bales, woven bags; electronic waste like cables and ICs, paper, wood and other organic materials. Depending on downstream requirements, the shredded material, with size defined by the fitted screen size, can be used directly or can pass to the next stage of size reduction, for example a G granulator.

# G Series

## General Purpose Shredder

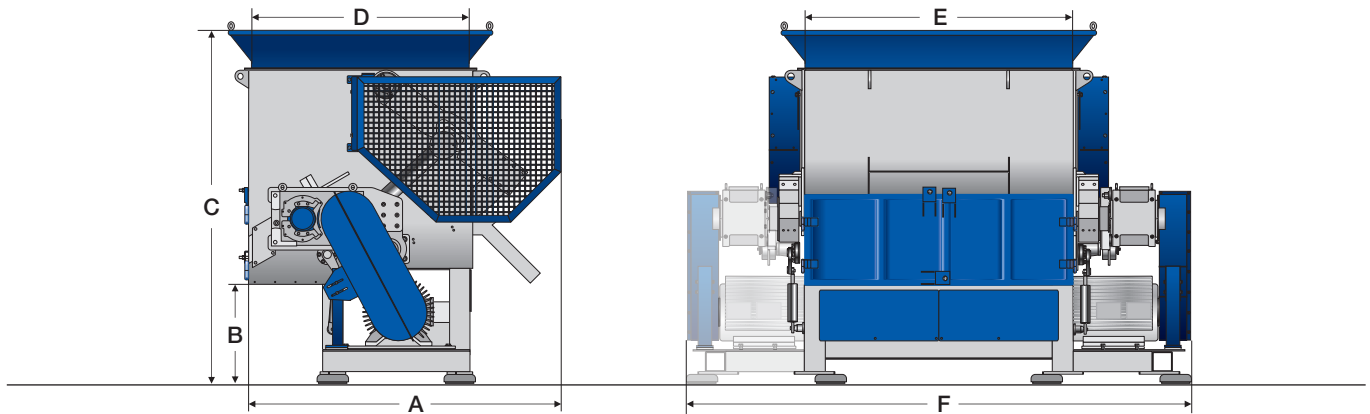

### Technical Specifications and Dimensions

Model	850	850+	1200	1500	2000
Rotor diameter (mm)	387	457	457	457	457
Rotor width (mm)	850	850	1130	1410	1970
Rotor speed (rpm)	74	74	74	74	74
Drive capacity (kW)	37	55	55	75	2 x 55
Rotor knives (pcs)	40/60	40/60	54/81	68/102	96/144
Stator blades (rows)	1 or 2	1 or 2	1 or 2	1 or 2	1 or 2
Ram feeder drive (kW)	3.75	3.75	5.6	5.6	5.6
Screen size (mm)	>40	>40	>40	>40	>40
Cutting chamber volume (m <sup>3</sup> )	1.16	1.37	1.82	2.27	3.16
Effective working area (mm)	690 x 730	800 x 730	800 x 1010	800 x 1290	800 x 1850
Weight approx (kg)	4200	4800	5500	6500	8500
A (mm)	2085	2300	2300	2300	2300
B (mm)	625	725	725	725	725
C (mm)	2435	2600	2600	2600	2600
D (mm)	1360	1590	1590	1590	1590
E (mm)	840	840	1120	1400	1960
F (mm)	1940	1985	2265	2590	3710

#### Virtus Equipment

311 Era Drive  
 Northbrook, IL 60062  
 Phone: 1-847-291-1800  
 sales@virtus-america.com

[virtus-equipment.com](http://virtus-equipment.com)

