

JIANGSU RUDONG GENERAL MACHINERY CO.LTD

LOAD TEST REPORT

SI.NO.: QR350-

Sample source		Set up at plant			
Description		Casing Elevator	Type	SLX 7"/65	Qty. 1Pcs
Method of sample		100%	Sample Qty.	1	Sample No 00408
Test std		API Spec 8A	Character	Leave factory	Condition 18°C
Test equipment	Name	Test-bed of compute control	Type	YEW-10000F	Equipment No. 301
	Precision	± 1.0%	Period of validity	2010.8.8	Test Date 2009.8.7
Load rating		65ton	Test load	97.5ton	Load time 5 mins

RESULT

Actual test load	97.5ton(877.5kN)	Load-Time
------------------	------------------	-----------

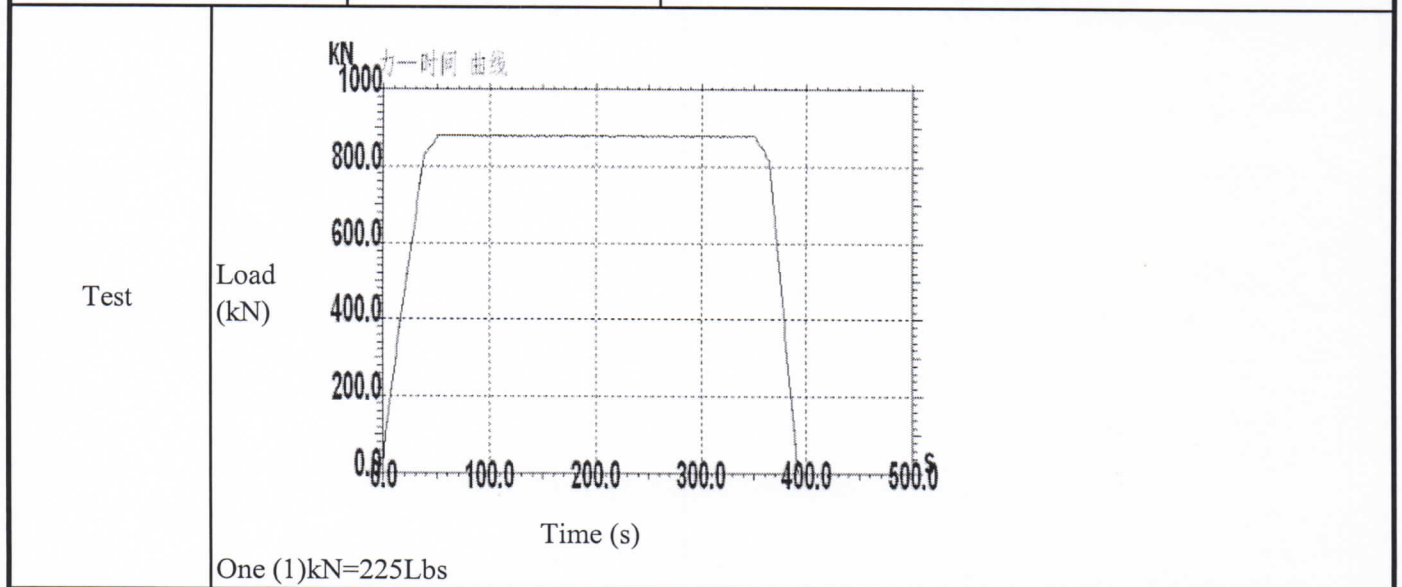

TEST RESULT:

OK

Remark		Seal
--------	--	------

Inspector : Song Jianhua

Engineer: Yin Zhigao

Date: 2010-4-28



JIANGSU RUDONG GENERAL MACHINERY CO.,LTD

Report of Material Test

Report NO.:

Test Item Result Spec. Type	No.	Chemical (%)							Mechanicals					
		C	S	Cr	Mn	Mo	P	Si	Ni	Yield Rp _{0.2} (MPa)	Tensile Rm (MPa)	Percentage Elongation A ₅ (%)	Contraction of area Z (%)	Champ (-20°) (J)
SLX 7/65 Casing Elevator	00408	0.300	0.020	0.520	0.740	0.190	0.015	0.480	0.480	685	865	17.0	49.5	53、56、55
Result:	OK													

Inspector : Xu Min、 Wu Zengyi

Auditing: Yin Zhigao

Date: 2010-4-28



Jiangsu Rudong General Machinery CO.,Ltd.

MAGNETIC PARTICLE INSPECTION CERTIFICATE

NO.:QR049

Part Name	Casing Elevator	Type	SLX 7"/65
Dispatch No.	00408	Qty.	1 (pcs)
Material	Alloy Steel	Face estate	12.5/ ✓
Heat treatment estate	Quench and Temper	Area thickness	See below
Instrument Model	CEW-6000	Method of Magnetization	Continuum
Method of Display	Fluorescence	Sensitivity	A 15/100
Blacklight lamp	>800uW/Cm ²	Acceptance Std.	GB9444 ASTME709

Test extent and place of assess casing:

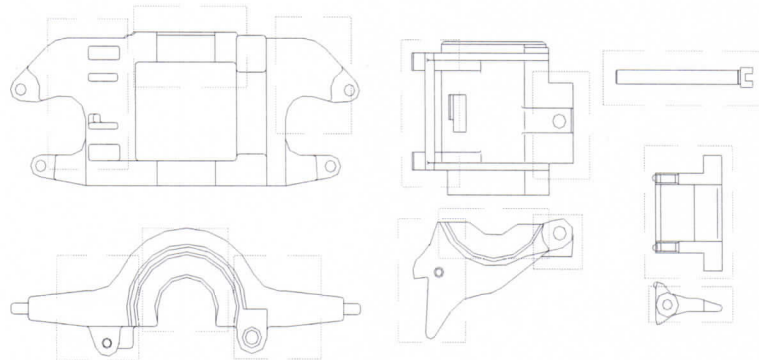

Find type of disfigurement and dimension(see above drawing)

Nonexistence

Quality grade of assess and /or conclusion:

Grade I /OK

Inspector	Xia Shupeng	Auditing	Wu Zengyi	Date(badge of department)	<p>2010-4-28 DEDICATED STAMP FOR PRODUCT INSPECTION</p>
-----------	-------------	----------	-----------	---------------------------	---