

**Turbo air**  
AIR CONDITIONER MANUFACTURER

4184 E. Conant St.  
Long Beach, CA 90808  
Tel. 888-900-1002  
Fax. 310-900-1088  
www.turboairinc.net

Project :

Model # :

Item # :

Qty :

Approval :

## Condensing Unit

**Model : TH010MR404A2**



### ≡ FEATURES / BENEFITS ≡

- Blue anti-corrosion-fin increases the life span of the coil.
- Seamless inner groove copper tube increases the heat exchange rate by reducing the space between the fin and copper tube.
- Highest quality compressor in the world.  

- Head pressure control stabilizes the freezing of liquid line, minimizes formation of flash gas to increase efficiency of the system, and prevents compressor damage by controlling high pressure.
- Experienced engineers have designed the system for maximum efficiency.
- Fan Blades : Specifically matched with motors and coil for maximum air movement and cooling.
- Control box is designed for easy installation.
- Low pressure control is adjustable.
- All the parts are compliant with industry standards and interchangeable with readily available parts.
- Wiring : Easily accessible. Compressor comes with a wiring harness that is manufactured with connections that will not come loose with vibration.
- Control box and service valves are located outside for easy service.
- Base : Heavy duty steel. Legs are 2-1/6" tall
- Cabinet : Prepainted with galvanized body. Protects against corrosion.
- All products carry UL, cUL, ISO 9001 approvals.

# Condensing Unit

## Model : TH010MR404A2

### PERFORMANCE CHART

	40°F( SST)	30°F	25°F	20°F	15°F	10°F	0°F	-10°F
90°F( AMBIENT)	-	9377	8362	7348	6497	5719	4332	3008
95°F	-	8544	7625	6706	5930	5212	3906	2614
100°F	-	7718	6883	6047	5336	4677	3436	2166
110°F	-	6309	5603	4898	4282	3703	2557	-

### SPECIFICATION

	TH010MR404A2
Compressor	RS70C1E
Line Size	3/8" Liquid 5/8" Suction
Receiver 90%	6
Fan Data	1 Fan (980CFM)
Dimensions	24.49(D) x 28.27(W) x 17.87(H)
Net Weight	136 Lbs
Power Supply	208-230/1ph/60hz
Compressor Amp	7
MCA	15
MOPD	15

Design and specifications subject to change without notice

- **WARRANTY :** 1 Year Compressor Warranty (4 Year extended warranty available)  
1 Year Fan Motor and Parts Warranty

### PLAN VIEW

(unit : inch)

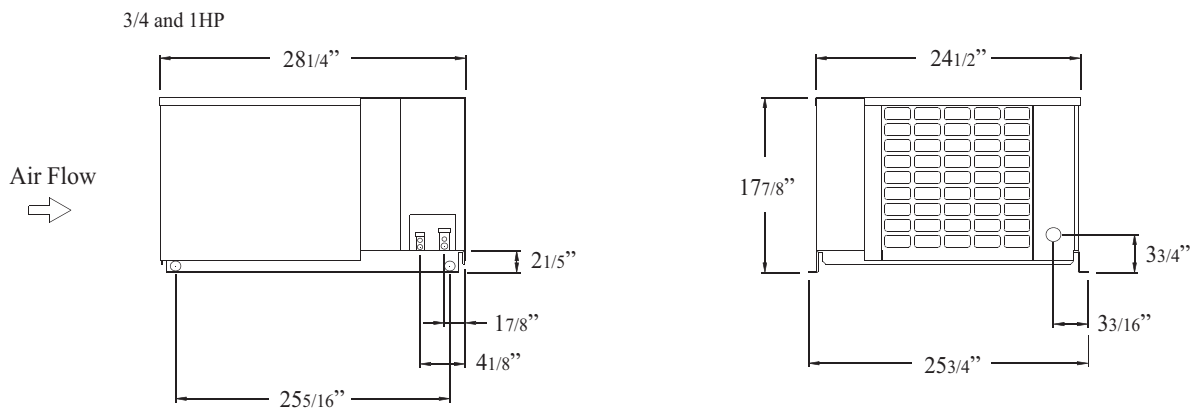

■ Toll Free : 888-900-1002

REFRIGERATOR MANUFACTURER  
**Turbo air**

**GERMAN KNIFE**

**RADIANCE**

**GREEN WORLD**

AIR CONDITIONER MANUFACTURER  
**Turbo air**