

Live Video Streaming using Raspberry Pi

P.Naresh¹, Shaik Chand Basha², T.Ravindra³

¹G.V.P College of Engineering (A)

²SION Semiconductors (p) ltd

³G.V.P College of Engineering (A)

E-mail: pediredla447@gmail.com

Abstract— This system is designed for continuous monitoring and also the system provides live streaming. The Live video transmission is widely used in the office, house and surveillance, conferencing, media broadcasting and applications that include remote assistance. This application system captures video and shares to the live streamer of YouTube channel with the movement of web page controlled Robot Car. First, the Raspberry Pi camera video from the Robot Car placed location is collected by the embedded Linux system. All data is processed, compressed and streamed by the processing Raspberry Pi. Then the video data are sent to live streamer of YouTube channel.

Keywords— Raspberry Pi 3 Board, Pi Camera, YouTube, Raspberry Pi Web Server, Robot Car, CLI, CSI, SSH.

I. INTRODUCTION

Everyone has to go to different places on the purpose of business (or) personal activities and has to be there a long time to fulfill those activities. Those persons must have to know day to day business activities and monitor staff performance, candidate interview performance, manufacturing production and know what activities are happening in surrounding of a particular place (or) many particular places. If someone is outside of their place (like home, office), in that time, that person would like to know what /how an action is happening in that place or in that surrounding place. Probably, if someone is out of town then that person would like to know what action is happening in surrounding home. At this time, this system can be used. If that person is a businessman, that person would like to monitor staff performance, candidate interview performance, manufacturing production. This system can be used for surveillance [4][7] in the business domain. If someone is doing IOT based application from far away, at that time that person can send appropriate instructions to things included in IOT based application by monitoring through this system.

II. HARDWARE AND SOFTWARE

A. Raspberry Pi 3 Model B

The Raspberry Pi [3] is there in two models- Model A and Model B. The Model A is the lowest price than Model B but lack some connectors. The intention of starting Raspberry pi is

teaching the basic computer science in schools but later turned out to be a wonder in the field of single board computers. The Pi 3 is 50% faster than the Pi 2.

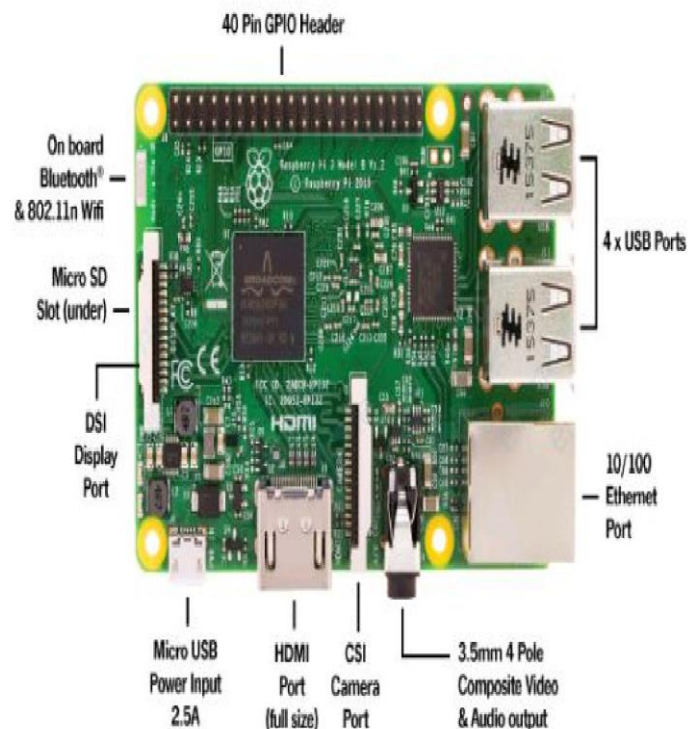

Fig. 1 Raspberry Pi 3 Model B

The Raspberry Pi 3 Model B which has Broadcom BCM2837 chipset, 1.2GHz Quad-core ARM Cortex-A53(64Bit) processor, 802.11 b/g/n Wireless LAN and Bluetooth 4.1, GPU: Dual Core Video IV @ Multimedia Co-Processor , 1GBLPDDR2 Memory, Micro USB socket 5V1, 2.5A for providing power supply, 10/100 Base-T Ethernet socket, Video output HDMI, Audio output 3.5mm jack, 4 x USB 2 ports, 40 pins for providing 27 GPIO pins as well as +3.3V, +5V and GND supply lines, 15-pin MIPI Camera Serial Interface (CSI-2), DSI display port.

B. Wi-Fi Router

The functions of the Router and the function of a wireless access point are performed by the Wi-Fi Router [4][6]. Accessing to the Internet or a private computer network is

provided by using the Wi-Fi Router. In this system, the Wi-Fi Router is used to connect Raspberry pi 3 Model B and control the Robot car through Raspberry Pi web server [1][4]. The Wi-Fi Router works as the DHCP Server to assign the IP addresses to host in a home and small areas [4]. In this System, the Raspberry Pi web server is accessed using the static IP in the LAN or the Public IP in the Different network. The Public IP is provided by ISP. The TP-Link TL-WR841N 300Mbps Wireless-N Router can operate this system within 80m range.

C. The Pi Camera Module



Fig. 2 The Pi Camera Module

The 5 MP Camera Module V1 was launched in 2013 and The 8 MP Camera Module V2 was launched in 2016. In this system, The 5 MP Camera Module V1 is used.

D. Robot Car

The Robot Car [1][5] is used for moving to the desired place by giving commands through the web browser from throughout the world by creating Raspberry Pi web server[3]. By using Robot Car, the live video streaming can be streamed to YouTube [8][11] from the desired place.

The robot Car has parts shown below,

- DC-6V 4 DC Motors
- 4 wheels
- Robot Car Chassis
- Battery holder

E. L298N Dual H-Bridge Motor controller

The L298N Dual H-Bridge Motor controller can be used to drive the Robot Car by giving instructions to the Raspberry Pi web server through the web browser from throughout the world [4][13].

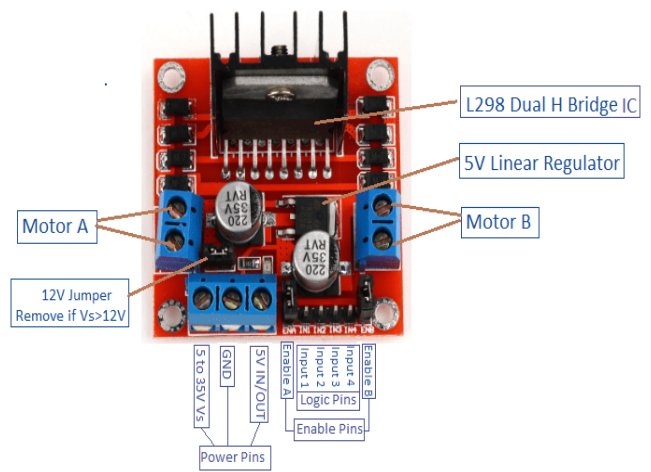

Fig. 3 The L298N Dual H-Bridge Motor controller

This module can be used to control the direction (clockwise or anti-clockwise) of the DC Motors according to giving instructions from the web browser. This module can be operated with 3 - 35v DC input voltage (V_{in}) to drive the motor. It consists of an onboard 5v regulator. If the supply voltage (V_{in}) is between 7 and 12V to drive the motor, the 5V DC can be sourced from the board. If the supply voltage is more than 12V, the 12V jumper has to be removed. The L298N dual H-bridge motor controller module is inexpensive.

F. Raspbian operating system

The Raspbian is the official supported Raspberry pi operating system-based on Debian. The Debian is an operating system composed of free software mostly carrying the GNU General Public License. The Debian was the default distribution on the Alpha boards.

III. BLOCK DIAGRAM

In this system, the two transceivers are there. These two transceivers are the transceiver 1 and the transceiver 2. The Transceiver 1 consists of Raspberry Pi 3 Board with the Power Supply, the Pi Camera Module [9], the In-built Wi-Fi Module, and the L298N Motor Controller [13]. The Transceiver 2 consists of the PC or Laptop or Mobile.

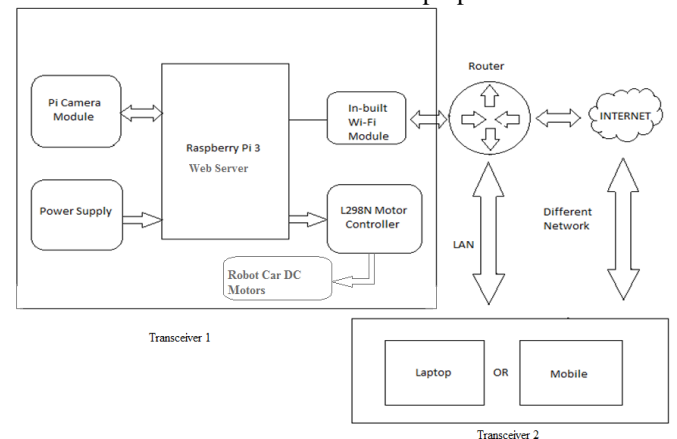

Fig. 4 Block diagram of the system

The operating system has to be installed on Raspberry pi 3 Board and updated and upgraded for application software packages [14]. The inbuilt Wi-Fi Module of Raspberry Pi 3 Board has to be configured to connect to the network. The Pi Camera is enabled and checked the proper working of Pi Camera [10]. The FFmpeg needs to be installed. The YouTube Channel is created for live video streaming on the YouTube [8][11]. The Transceiver 1 block consists of the L298N Motor Controller for controlling the Robot Car. The Proper connections have to be given to the L298N Motor Controller [13][4] pins from the Raspberry PI 3 Board and the DC Motors of Robot Car for proper controlling the Robot Car. This Robot Car can be controlled through Raspberry Pi Web server [1][3][4]. The Apache and the PHP and the MySQL have to be installed [4][12]. The system, the Router is used and the static IP is set up or the public IP is provided by ISP to the Raspberry Pi Web Server for controlling the Robot Car on the Local Network or throughout the world [4][2]. The Transceiver 2 block devices are the PC or Laptop or Mobile. These devices must have the internet connection to watch the live video streaming on the YouTube [8] and to send commands to the Raspberry Pi Web Server from the Web Browser for controlling the Robot Car [4][5].

IV. IMPLEMENTATION OF THE SYSTEM

The Raspberry Pi doesn't have a hard disk or enough internal memory capacity, so an SD card needs to be used for the data storage and for all other operations of the Pi. First, a Linux based operating system needs to be installed in the Raspberry Pi. The official download page is visited by going to www.raspberrypi.org web page from the pc or laptop. The Raspbian is the official supported Raspberry pi operating system-based on Debian. The Raspbian icon is clicked. The Raspbian stretch with desktop and recommended software download zip file can be seen and clicked for downloading an image on another machine. That downloaded image is put into SD card. After that SD card is inserted into a micro SD card slot. A mouse, keyboard, and display are needed to work with the Raspberry Pi. The 2 USB ports are available to connect a mouse and a keyboard. One HDMI port is available to connect a display. The Raspberry Pi 3 is powered up using the external adapter. Now, The SSH is enabled using the `raspi-config` file. The Raspberry Pi 3 is connected to the LAN port of the router through Ethernet cable for internet access to Raspberry Pi. If separate keyboard, mouse, and display are not available then a client (putty or MobaXterm) installed the PC or Laptop can be used to access the command line of the Raspberry Pi. The VNC can be used to access the graphical interface of the Raspberry Pi from another machine. The Updating and upgrading to download and install the latest kernel, GPU firmware, and applications is done by executing "sudo apt-get update", "sudo apt-get upgrade" command line commands. After updating and upgrading, the Wi-Fi router is connected to Raspberry pi 3 through in-built Wi-Fi. The Setting up Wi-Fi via the Graphical user interface or the command line interface is done for connecting Raspberry Pi 3 board to the Wi-Fi

Router. The system uses pi camera module for capturing video.

A. Interfacing pi camera to Raspberry Pi 3 board

The Pi Camera module is used to get high definition video [9]. The Pi Camera module can be attached to CSI interface of Raspberry Pi 3 Board through the 15-pin flex cable [10]. The Transceiver 1 section consists of this Pi Camera Module. The Pi Camera Module is used in this project as an input sensor to capture high definition video from the desired place. This data are processed, compressed and transferred to the YouTube Channel by the processing Raspberry Pi. The Raspberry Pi 3 Board consists of the CSI (Camera Serial Interface) slot. The Pi Camera module can be attached to CSI interface of raspberry pi 3 board through the 15-pin flex cable. After that, the setting up the camera software by two command line commands (i.e. Sudo apt-get update, Sudo apt-get upgrade) and enabling camera module is done. The `raspi-config` is used to enable the camera [10].

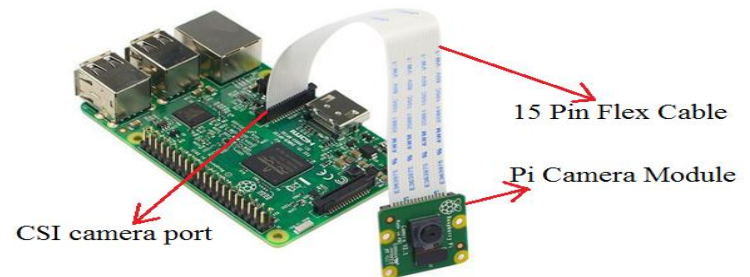

Fig. 5 Pi Camera Interfacing to CSI Interface

The updating and upgrading are done software by using command line instructions for downloading and installing the latest kernel, GPU firmware, and applications. The **Raspistill** and **raspivid** are the command line tools for taking still photographs and video respectively using camera module [9][10]. In the system, the live video streaming is done using the YouTube channel. The setting up YouTube channel and installing FFmpeg in Raspberry Pi to encode the stream to the YouTube is done.

B. Installing FFmpeg to encode the stream to YouTube

Now, an internet connection is there and the Raspberry Pi powered-up with the Raspberry Pi camera connected. So, FFmpeg needs to be installed to encode the stream to the YouTube channel in FLV format [8][11]. The FLV is a flash video container. The FLV gives the possibility to deliver videos over the internet using Adobe Flash Player.

C. Setting up a YouTube channel

Everything on the Raspberry Pi has to be installed. The YouTube account Sign up needs to be done, if a YouTube account is not there. The Account for live streaming has to be enabled and verified. For enabling and verifying, the Channel option needs to be gone from the YouTube homepage and the Video Manager and the Live Streaming are clicked. Now prompting has to be done to verify YouTube account using

either SMS or an automated telephone message with a verification code. After verification, 'stream name/key' can be retrieved under 'ENCODERSETUP' from the live streaming page on YouTube account. The Reveal has to be clicked to show unique streaming key [8][11]. That key is noted down for use in the command line command to get YouTube Live Streaming. The following command has to be executed in command line of Raspberry Pi to get live video streaming on the YouTube.

```
raspivid -o - -t 0 -vf -hf -fps 10 -b 500000 | ffmpeg -re -ar 44100 -ac 2 -acodec pcm_s16le -f s16le -ac 2 -i /dev/zero -f h264 -i - -vcodec copy -acodec aac -ab 128k -g 50 -strict experimental-f flv rtmp://a.rtmp.youtube.com/live2/STREAM-KEY
```

Executing this command every power-up time in the command line is difficult if live streaming on the YouTube needs continuously. In the system, the rc.local method is used for running a command line command at boot on a Raspberry Pi. The file /etc/rc.local needs to be edited using the nano editor. The Editing is done with root permissions through the "Sudo nano /etc/rc.local" command. If the running that command line command is done as the root user in rc.local, "su - USERNAME -c" is added before that command. The "su - USERNAME -c" is used to make command lines calls from root user. The **su** stands for substitute user. The su can be used by a computer user to execute commands with the privileges of another user account. The Raspberry Pi default username is pi. The system captures video, shares to live streamer of the YouTube channel with the movement of Web Browser controlled robot car. For controlling the robot car, the L298N dual H-bridge motor controller is used. The Motor controller outputs are connected to DC motors. The DC Motors rotation (clockwise or anti-clockwise) is based on given outputs. The Robot Car movement is based on DC Motor rotations. The Motor controller outputs are changed by giving 4 logical inputs from Raspberry Pi GPIO pins. In the system, 4 GPIO pins are set as output mode. The 4 GPIO pins outputs are set by the web page of Robot Car controlling options.

D. Interfacing the L298N Dual H-Bridge Motor Controller to Pi 3 and Robot Car DC motors

The interfacing the L298N Dual H-Bridge Motor controller [4][13] to the Raspberry pi 3 can be done very easily. The 12V power supply is connected to the L298N Dual H-Bridge Motor controller and the Robot Car left and right DC Motors are connected to Motor1 and Motor2 pins of L298N Motor controller respectively.

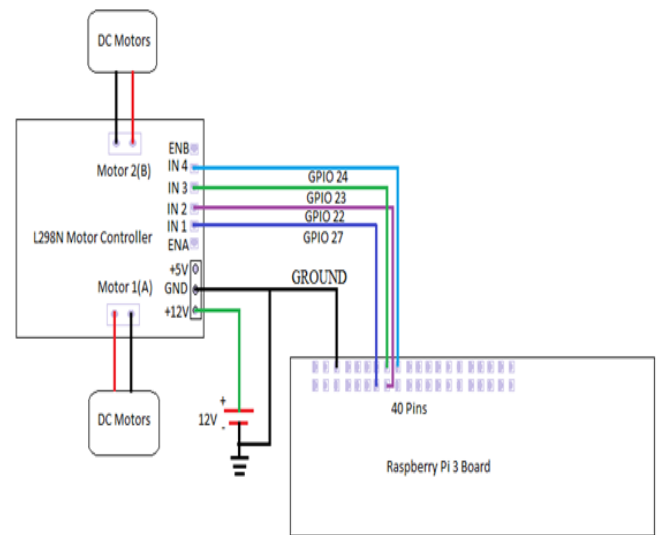

Fig. 6 The L298N Motor Controller Interfacing to Raspberry Pi 3

The GND terminals of the Raspberry Pi and the L298N Motor controller are made as common (means their grounds are connected to each other). The robot car is driven with 4 DC Motors by giving 4 logical inputs using 4 GPIO pins of Raspberry Pi 3 and putting without GPIO pins connections of Raspberry Pi 3 to ENA and ENB pins because both motor 1 and motor 2 channels are being used.

E. A web server on the raspberry pi

In this system, the Robot Car has to be controlled remotely over the internet or the LAN. For controlling the Robot Car remotely over the internet or the LAN, any web hosting service or the web server on the Raspberry Pi can be used. Instead of the web server on the Raspberry Pi, the web hosting services can be used. But for getting web hosting services needs to be paid every month/year. In this system, the Robot Car is controlled remotely by the Web Server on the Raspberry Pi [1][2][4]. The Apache server software, the PHP, and the MySQL database are installed in the Raspberry Pi. The web page can be designed using the suitable editor like nano or leafpad. The default directory for the web server is /var/www. The web page of the Robot Car controlling options is designed using the PHP, the HTML, and the CSS. The Static IP is used to access the Raspberry Pi Web Server on the LAN. The Public IP can be provided by ISP to access the Raspberry Pi Web Server on the different network.

The entire transceiver 1 section arrangement is shown in fig.7. The Transceiver 1 has the robot car, the raspberry pi web server, the L298N Motor controller, the battery holder.

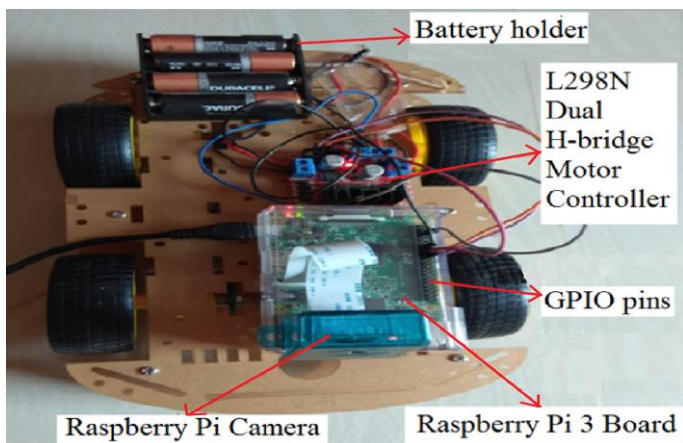

Fig. 7 Arrangement of the transceiver 1

V. RESULTS

Before live streaming, the live stream of the YouTube channel is in offline mode. The live stream of the YouTube channel in offline mode is shown in fig. 8.

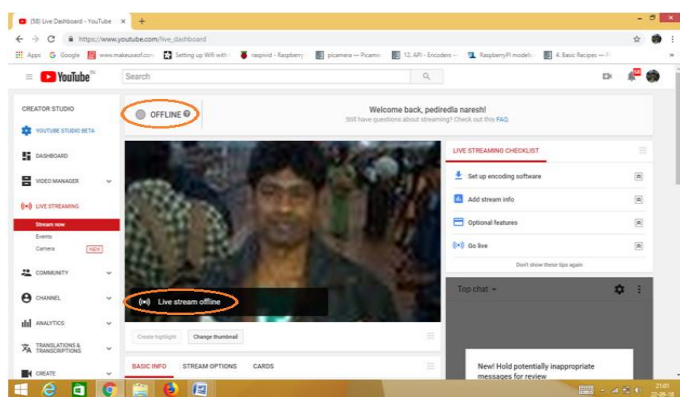

Fig. 8 The live stream of the YouTube channel is in offline mode

The combination of the raspivid command and FFmpeg command has been executed by executing the “su” command on startup. The Live Video Streaming has been provided in the Live Stream of YouTube channel in Live Mode. That is shown in fig. 9.

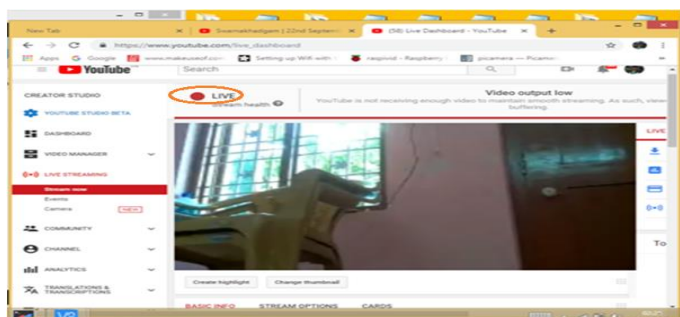

Fig. 9 Live video streaming on YouTube Channel

The “LIVE NOW” indicator has been indicated the present live streaming video in videos list. The previous videos with the time are shown in videos list. The Captured videos' list in Video Manager is shown in fig. 10.

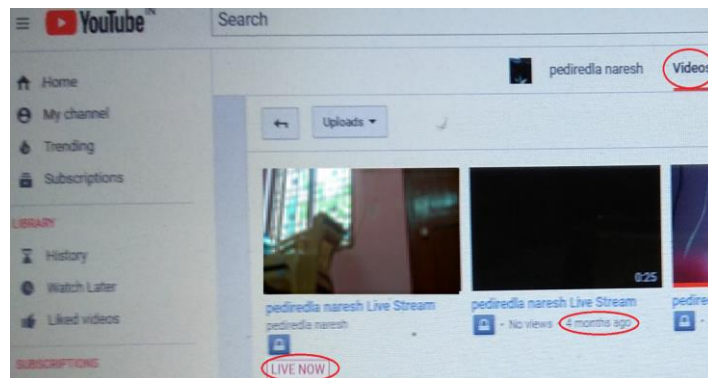

Fig. 10 Captured videos' list in Video Manager

The web page designed for robot car controlling options is shown in fig. 11. The Buttons are created for the forward and backward, stop, turn right, coast, turn left motions. When the user clicks the button, the corresponding PHP code for the movement is executed in the server. The address for the web page is 192.168.x.x/controlRobot.php.

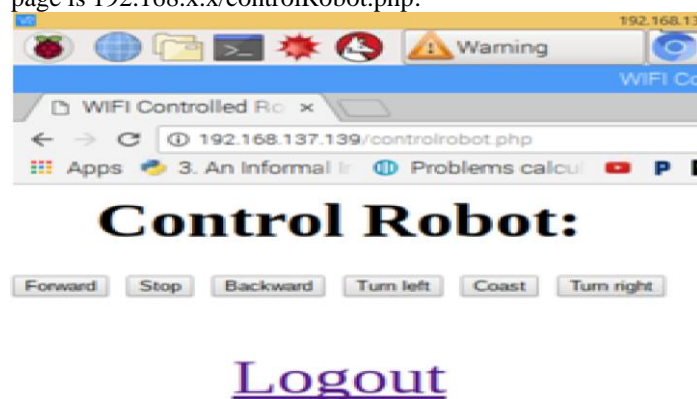

Fig. 11 Web Page of Robot Car Control options

The developed system is successful in streaming the live video to the YouTube channel from the desired place using Robot Car.

VI. APPLICATIONS

1. The Surveillance system, **surveillance** is used in Airports, theaters, railway stations, shopping malls to monitor behavior, activities, or other changing information for the purpose of influencing, managing, directing, or protecting people. Surveillance is used by governments for intelligence gathering, prevention of crime, the protection of a process, person, group or object, or the investigation of crime.
2. Industrial applications such as manufacturing and material handling systems.

3. Conferencing.
4. Media broadcasting.
5. This system can be used with the consumer, commercial, industrial, and infrastructure IOT applications.

VII. CONCLUSION

The Pi Camera and the L298N Motor controller are interfaced to the Raspberry Pi board. The Robot Car DC Motors are interfaced to the L298N Motor controller. The Camera option is enabled in Rasp-config. The YouTube channel is created and the live streamer is enabled for live video streaming on YouTube. The Raspberry Pi Web Server is created. The Web page of Robot Car controlling options is designed for moving the Robot Car to the desired place and capturing video from the desired place. Hence Live Video Streaming System Using Raspberry Pi was developed. The developed system is successful in streaming live video to the YouTube channel and controlling Robot Car to move the Robot Car to the desired place. In this project, only one input sensor is used to capture the HD video. This thesis can be further extended by taking multiple inputs with providing multiple camera ports to the Raspberry Pi Board for getting 360° views at a time. This thesis can be further added to IOT projects by watching this live video streaming for controlling things in the home, in office, and in industry. This thesis can be implemented using GSM and GPS module when this system is without Wi-Fi range.

ACKNOWLEDGMENT

I express my sincere gratitude to my guides Mr. Shaik Chand Basha, Asst. Professor. T. Ravindra who have supported me throughout this project.

REFERENCES

- [1] Ron Oommen Thomas and K. Rajasekaran, "Remote Monitoring and Control of Robotic Arm with Visual Feedback using Raspberry Pi", International Journal of Computer Applications (0975 – 8887) Volume 92 No.9, April 2014.
- [2] V. Ramya, B. Palaniappan, T. Akilan "Embedded System for Robotic Arm Movement Control using Web Server and ZigBee Communication", International Conference on Research Trends in Computer Technologies, Proceedings published in International Journal of Computer Applications® (IJCA) (0975 – 8887), pg 30-34, 2013.
- [3] Wan MuhamadHanif Wan Kadira, Reza EzuanSaminb, Babul Salam Kader Ibrahim C. "Internet Controlled Robotic Arm", Science Direct, International Symposium on Robotics and Intelligent Sensors, pg 1065-1071, 2012.
- [4] R.Karan kumar, N. Raju "Surveillance & Live Streaming System using Raspberry Pi", International Journal of Science, Engineering and Technology Research (IJSETR) Volume 5, Issue 8, August 2016.
- [5] R.A. Kadu, Prof. V.A. More, P.P. Chitte, J.G. Rana, M.R. Bendre. "Wireless Control & Monitoring of Robotic Arm" International Journal of Computer Technology and Electronics Engineering (IJCTEE) Volume 2, Issue 1, pg 28-38, 2010.

- [6] Kavitha Mamindla, Dr.V.Padmaja, CH.NagaDeepa, "Embedded Real Time Video Monitoring System Using Arm", IOSR Journal of Engineering (IOSRJEN) eISSN: 2250-3021, p-ISSN: 2278-8719 Vol. 3, Issue 7 (July. 2013), ||V6 || Page(s) 14-18.
- [7] Dr. Shantanu K. Dixit and Mr. S. B. Dhayagonde," Design and Implementation of e-Surveillance Robot for Video Monitoring and Living Body Detection", International Journal of Scientific and Research Publications, Volume 4, Issue 4, April 2014.
- [8] Ashish U. Bokade and V. R. Ratnaparkhe, "Video Surveillance Robot Control using Smartphone and Raspberry Pi" International Conference on Communication and Signal Processing, April 6-8, 2016, India.
- [9] www.electronicwings.com, Pi Camera Module Interface with Raspberry Pi using Python.
- [10] www.raspberrypi.org, Camera Configuration.
- [11] www.makeuseof.com, live stream to YouTube with a Raspberry Pi.
- [12] https://howtoraspberrypi.com/how-to-install-web-server-raspberrypi-lamp/, How to install a web server on the Raspberry Pi (Apache + PHP + MySQL).
- [13] https://www.smart-prototyping.com/L298N-Dual-H-bridge-Motor-Driver-Board, L298N Dual H-Bridge Motor Driver Board
- [14] https://theipi.io/how-to-install-raspbian-on-the-raspberry-pi/, how to install Raspbian on the raspberry pi.



Mr. P.Naresh, born in 1990, received B. Tech in Electronics and Communication Engineering from the Dadi Institute of Engineering and Technology, Anakapalle, AP in 2012. He is currently pursuing M. Tech in VLSI Design and Embedded Systems at the Gayathri Vidya Parishad College of Engineering (A), Visakhapatnam, AP since 2016. He is doing research in embedded systems in live video streaming.



Mr. Shaik Chand Basha received M.S from M.S. Ramaiah College of Engg and B.Tech in ECE from Khader Memorial College of Engineering & Technology. He is working as Design Verification Engineer at SION Semiconductors (p) Ltd, Marathahalli, Bengaluru, Karnataka, India.



Mr. T.Ravindra received M.Tech in VLSI System Design Aditya Institute of Technology and Management and B.Tech in ECE from Sri Prakash College of Engineering. He has 6 years of teaching experience and is Assistant Professor of ECE Department, G. V. P. College of Engineering (A), Visakhapatnam, AP, India.