

# M1280D TOWER CRANE

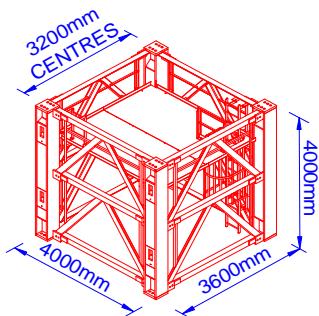
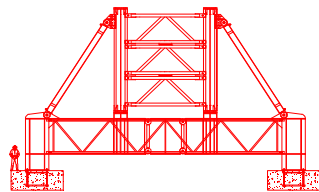
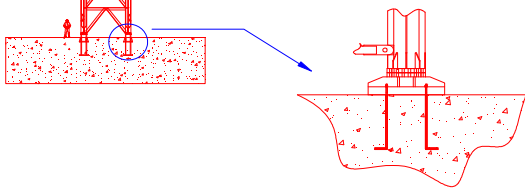

TYPICAL LOADS	
LOAD	RADIUS
150.0T	17.8m
132.0T	20.0m
100.0T	25.0m
50.0T	45.0m
33.1T	60.0m
13.0T	80.0m
AUX. HOIST	
LOAD	RADIUS
16.0T	77.8m
13.2T	83.9m

## Technical Data Sheet

**FAVELLE**  
**FAVCO**

**M1280D RADIUS AND CAPACITY (METRIC UNITS - WITH AUX. HOIST )**



Boom Length	Max Rad. for Max WLL	Min Rad.	WLL at Min Rad.	1 FALL																				Max Rad.	WLL at Max Rad.
				Radius (metres) & Capacity (tonnes)																					
(m)	(m)	(m)	(T)	7.5	10.0	15.0	20.0	25.0	30.0	35.0	40.0	42.5	45.0	47.5	50.0	52.5	55.0	57.5	60.0	65.0	70.0	75.0	80.0	(m)	(T)
82.6	27.5	8.2	50.0	-	50.0	50.0	50.0	50.0	48.4	45.0	41.2	39.5	37.8	36.0	34.2	32.4	30.6	28.8	27.0	23.5	20.0	16.5	13.0	81.2	12.1
73.4	40.0	7.4	50.0	50.0	50.0	50.0	50.0	50.0	50.0	50.0	50.0	48.0	47.0	43.9	40.8	38.1	35.3	32.7	30.0	25.0	20.9	-	-	72.3	18.8
64.2	42.9	6.7	50.0	50.0	50.0	50.0	50.0	50.0	50.0	50.0	50.0	50.0	48.0	44.9	41.8	39.2	36.6	33.8	31.0	-	-	-	-	63.4	27.2
55.0	45.0	6.0	50.0	50.0	50.0	50.0	50.0	50.0	50.0	50.0	50.0	50.0	50.0	45.8	42.5	38.0	-	-	-	-	-	-	-	54.5	34.4
45.8	42.5	5.7	50.0	50.0	50.0	50.0	50.0	50.0	50.0	50.0	50.0	50.0	47.0	-	-	-	-	-	-	-	-	-	-	45.6	46.3
36.6	36.8	4.9	50.0	50.0	50.0	50.0	50.0	50.0	50.0	50.0	50.0	-	-	-	-	-	-	-	-	-	-	-	-	36.8	50.0

Boom Length	Max Rad. for Max WLL	Min Rad.	WLL at Min Rad.	2 FALL																				Max Rad.	WLL at Max Rad.
				Radius (metres) & Capacity (tonnes)																					
(m)	(m)	(m)	(T)	7.5	10.0	15.0	20.0	25.0	30.0	35.0	40.0	42.5	45.0	47.5	50.0	52.5	55.0	57.5	60.0	65.0	70.0	75.0	80.0	(m)	(T)
73.4	-	7.4	80.0	80.0	80.0	80.0	80.0	80.0	72.0	64.5	54.5	50.8	47.0	43.9	40.8	38.1	35.3	32.7	30.0	25.0	20.9	-	-	72.0	19.1
64.2	24.5	6.7	100.0	100.0	100.0	100.0	100.0	98.1	79.0	65.5	55.5	51.8	48.0	44.9	41.8	39.2	36.6	33.8	31.0	-	-	-	-	63.1	27.5
55.0	24.7	6.0	100.0	100.0	100.0	100.0	100.0	98.9	80.2	66.8	56.8	52.9	49.0	45.8	42.5	38.0	-	-	-	-	-	-	-	54.2	34.9
45.8	24.9	5.3	100.0	100.0	100.0	100.0	100.0	99.6	81.2	67.9	57.0	52.0	47.0	-	-	-	-	-	-	-	-	-	-	45.3	46.4
36.6	25.0	4.6	100.0	100.0	100.0	100.0	100.0	100.0	81.9	65.0	-	-	-	-	-	-	-	-	-	-	-	-	-	36.4	60.2

Boom Length	Max Rad. for Max WLL	Min Rad.	WLL at Min Rad.	3 FALL																				Max Rad.	WLL at Max Rad.
				Radius (metres) & Capacity (tonnes)																					
(m)	(m)	(m)	(T)	7.5	10.0	15.0	20.0	25.0	27.5	30.0	32.5	35.0	37.5	40.0	42.5	45.0	47.5	50.0	52.5	55.0	57.5	60.0	62.5	(m)	(T)
64.2	13.3	6.2	150.0	150.0	150.0	142.4	123.0	96.9	85.8	76.5	68.7	61.9	56.1	51.0	46.6	42.6	39.0	35.7	32.8	30.1	27.7	25.5	23.6	63.4	22.9
55.0	17.6	5.5	150.0	150.0	150.0	150.0	129.2	98.6	87.5	78.2	70.4	63.7	57.8	52.8	48.3	44.4	40.8	37.7	34.9	-	-	-	-	54.5	32.8
45.8	17.7	4.9	150.0	150.0	150.0	150.0	130.7	99.6	89.0	79.8	71.9	65.2	59.4	54.4	50.0	46.1	-	-	-	-	-	-	-	45.6	45.2
36.6	17.8	4.2	150.0	150.0	150.0	150.0	132.0	101.5	91.0	81.9	73.5	65.0	-	-	-	-	-	-	-	-	-	-	-	36.7	59.2

Boom Length	Max Rad. for Max WLL	Min Rad.	WLL at Min Rad.	AUXILIARY HOIST - 1 FALL																Max Rad.	WLL at Max Rad.
				Radius(metres) & Capacity (tonnes)																	
(m)	(m)	(m)	(T)	10.0	15.0	20.0	25.0	30.0	35.0	40.0	45.0	50.0	55.0	60.0	65.0	70.0	75.0	80.0	(m)	(T)	
82.6	77.8	9.1	16.0	16.0	16.0	16.0	16.0	16.0	16.0	16.0	16.0	16.0	16.0	16.0	16.0	16.0	16.0	14.6	83.9	13.2	
73.4	74.8	8.4	16.0	16.0	16.0	16.0	16.0	16.0	16.0	16.0	16.0	16.0	16.0	16.0	16.0	16.0	-	-	74.8	16.0	
64.2	64.8	7.6	16.0	16.0	16.0	16.0	16.0	16.0	16.0	16.0	16.0	16.0	16.0	16.0	-	-	-	-	64.8	16.0	
55.0	57.2	6.9	16.0	16.0	16.0	16.0	16.0	16.0	16.0	16.0	16.0	16.0	16.0	-	-	-	-	-	57.2	16.0	
45.8	48.4	6.2	16.0	16.0	16.0	16.0	16.0	16.0	16.0	16.0	16.0	-	-	-	-	-	-	-	48.4	16.0	
36.6	39.5	5.5	16.0	16.0	16.0	16.0	16.0	16.0	16.0	-	-	-	-	-	-	-	-	-	39.5	16.0	

**NOTE:**  
**1. ON REMOVAL OF FLY JIB AND FLY HOOK 1.0 TONNE EXTRA CAPACITIES ALLOWED AT ALL RADII**

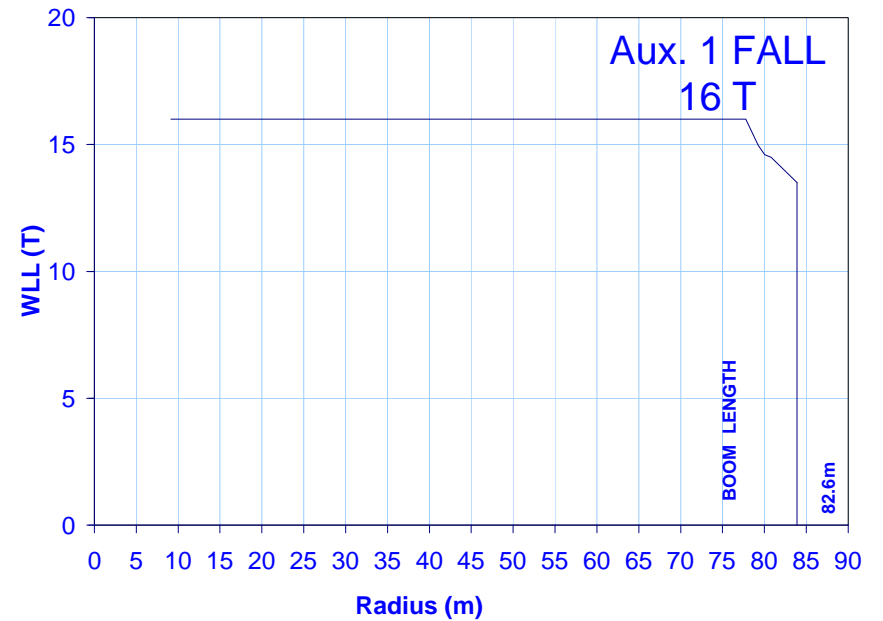
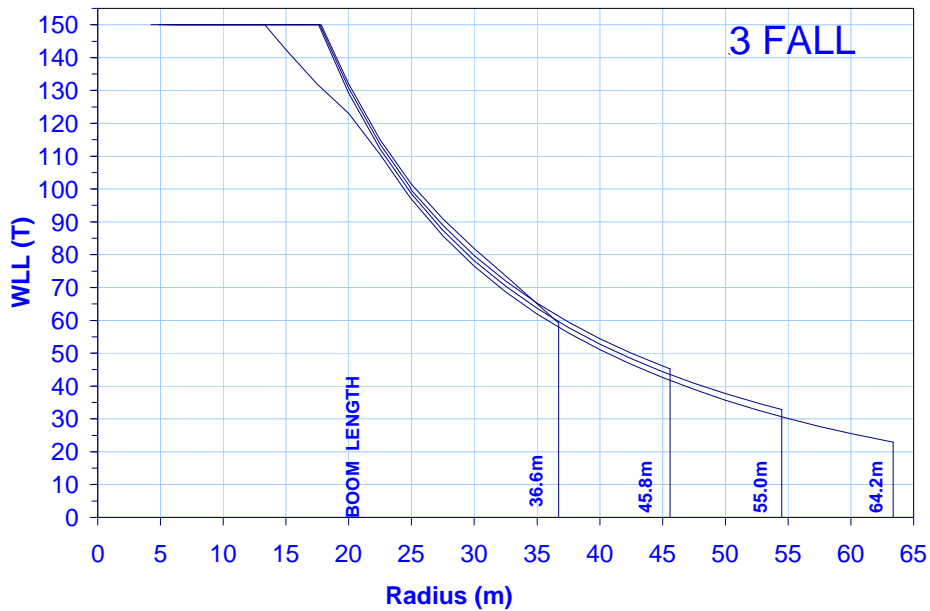
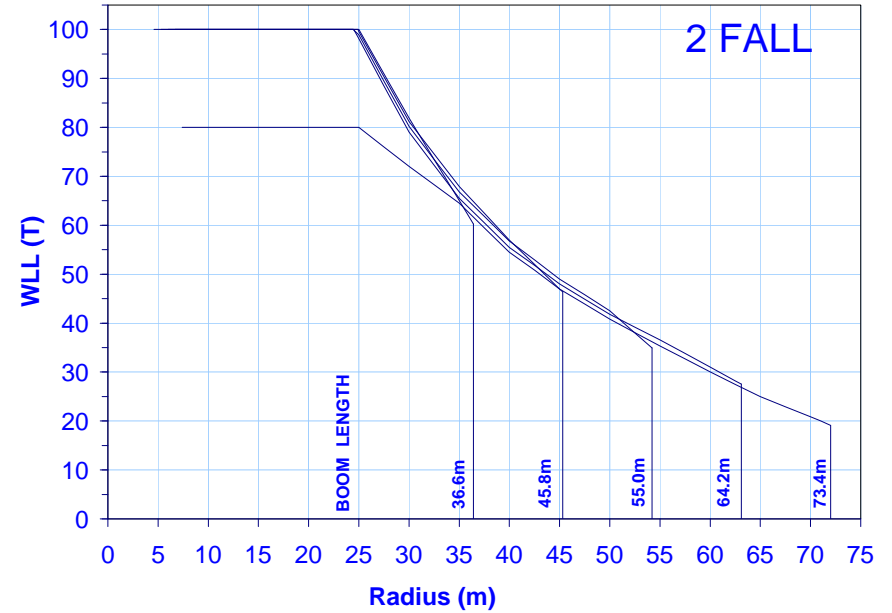
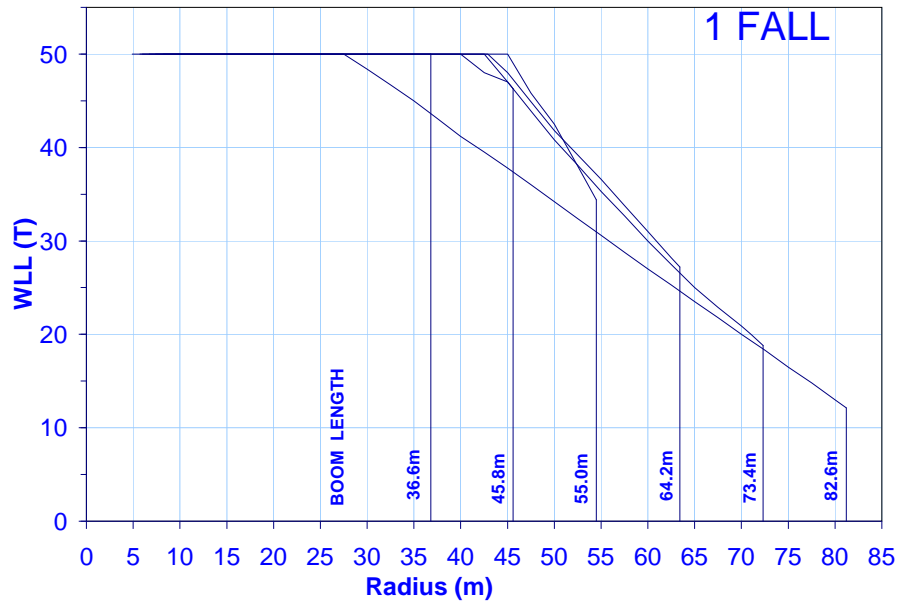

HOIST SPEED

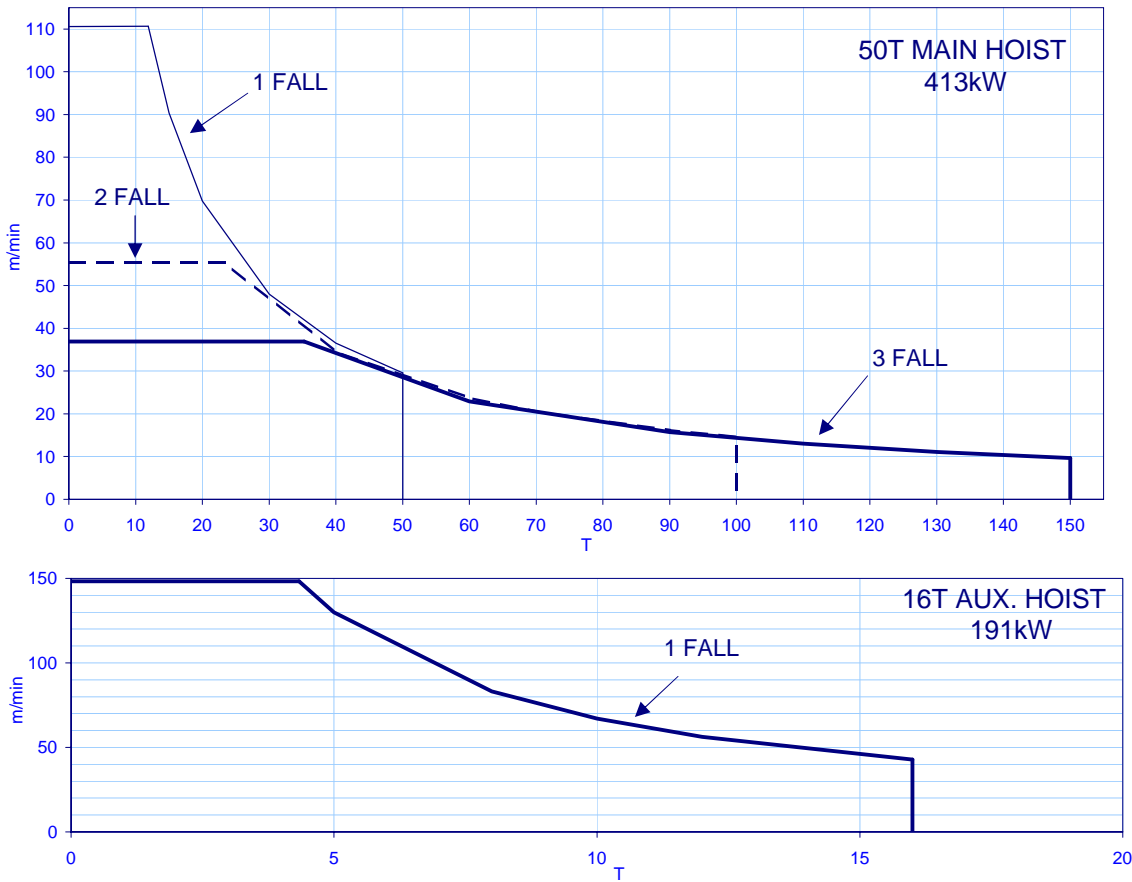

	LOAD (T)	SPEED (m/min)
1 FALL	11.9	110.6
	15.0	90.3
	20.0	69.8
	30.0	48.0
	40.0	36.6
2 FALL	50.0	29.5
	23.4	55.3
	40.0	34.5
	60.0	23.7
	70.0	20.5
3 FALL	90.0	16.1
	100.0	14.6
	35.2	36.9
	60.0	22.9
	90.0	15.7
AUX. (1 FALL)	110.0	13.0
	130.0	11.1
	150.0	9.7
	4.3	148.3
	5.0	129.9
	8.0	83.2
	10.0	67.1
	12.0	56.3
	16.0	42.7

LUFF&SLEW SPEEDS

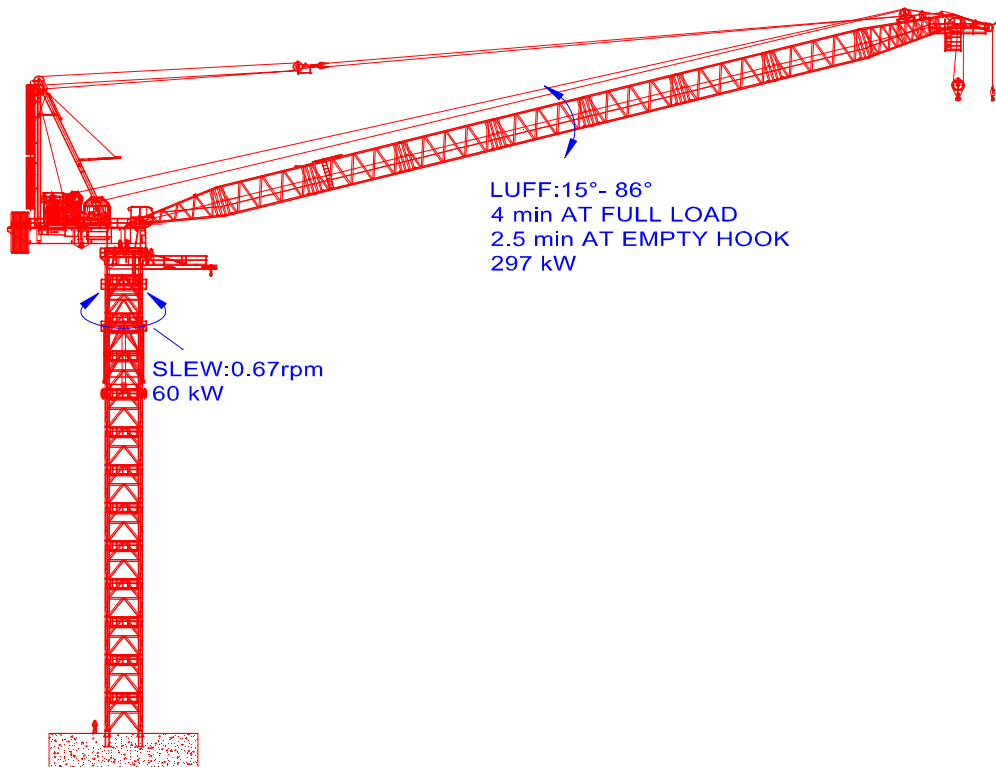

# M1280D GENERAL DIMENSIONS (TYPICAL CASES AT 64.2m BOOM LENGTH)



## CRANE FREE-STANDING WITHOUT CLIMBING FRAME

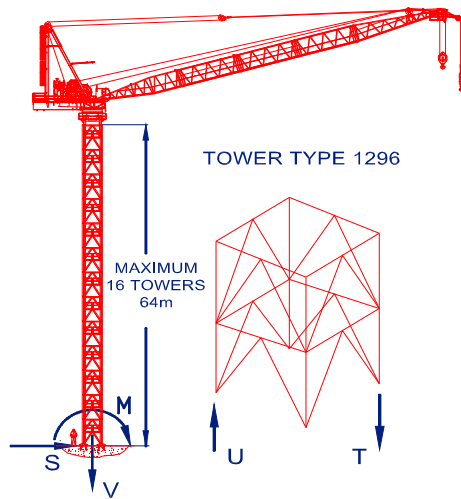

### BUILDING REACTION

Design Load	I/S*	O/S <sup>‡</sup>	O/S high ^	Unit
NO. of Towers	16	16	15	-
M	2773	1680	5343	mT
V	501	395	386	T
S	12	51	118	T
T	738	470	1277	T
U	487	273	1084	T
Ht <sub>Total</sub>	64	64	60	m

## INTERNAL CLIMBER ON COLLARS

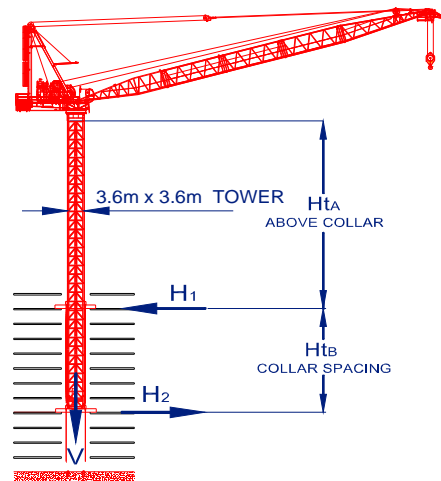

### BUILDING REACTION

Design Load	I/S*	O/S <sup>‡</sup>	O/S high^	Unit
NO. of Towers	16	16	15	-
V	506	400	391	T
H <sub>1</sub>	148	88	282	T
H <sub>2</sub>	138	44	183	T
Ht <sub>A</sub>	46	46	42	m
Ht <sub>B</sub>	18	18	18	m
Ht <sub>Total</sub>	64	64	60	m

## WITH CLIMBER- ONE TIE ABOVE THE BASE

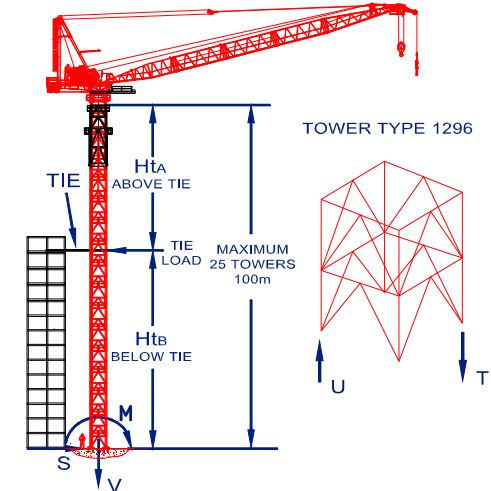

### BUILDING REACTION

Design Load	I/S*	O/S <sup>‡</sup>	O/S high^	Unit
NO. of Towers	25	25	23	-
TIE	91	85	251	T
M	1326	602	2105	mT
V	610	505	486	T
S	80	36	137	T
T	446	259	587	T
U	141	7	344	T
Ht <sub>A</sub>	50	50	46	m
Ht <sub>B</sub>	50	50	46	m
Ht <sub>Total</sub>	100	100	92	m

\*:IN SERVICE WIND=20 m/s  
 ‡:OUT OF SERVICE WIND= 42 m/s  
 ^:HIGH WIND (i.e. CYCLONE)= 65 m/s

Notes:

- Structure is designed using permissible stress method. These loads will vary by change of boom length, height and type of tower, actual site wind conditions, no of falls and change of wind speed.
- To calculate alternative options for M1280D refer to Favelle Favco Design Sheet named "Crane Weight Wind Chart".

MACHINERY DECK ASSEMBLY

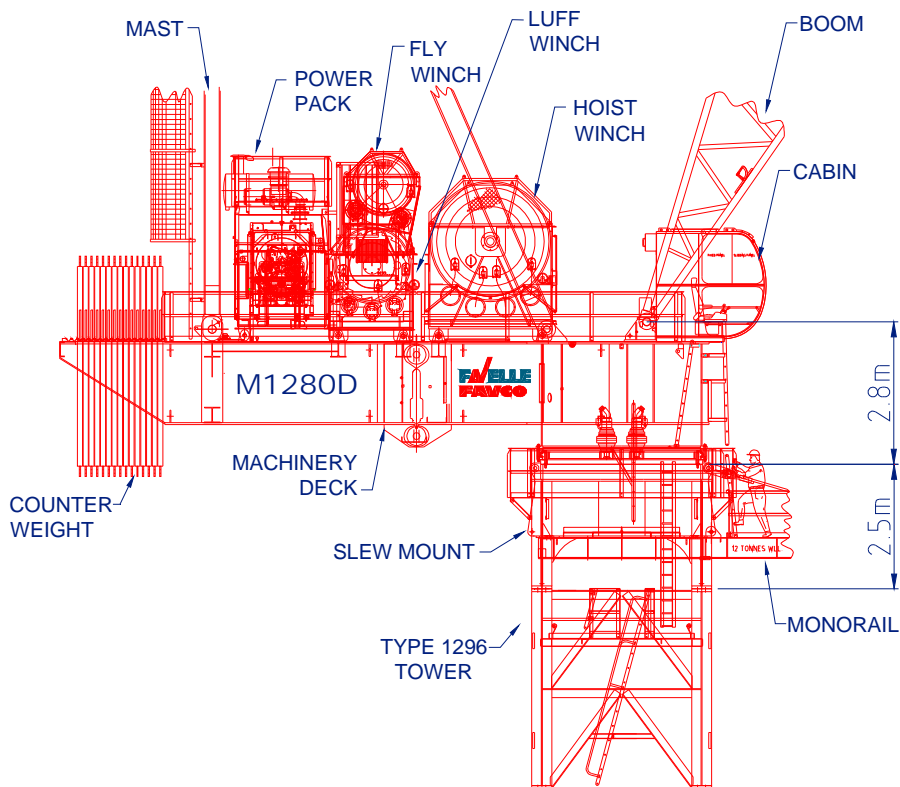

EXTERNAL CLIMBING INSTALLATION CLEARANCE

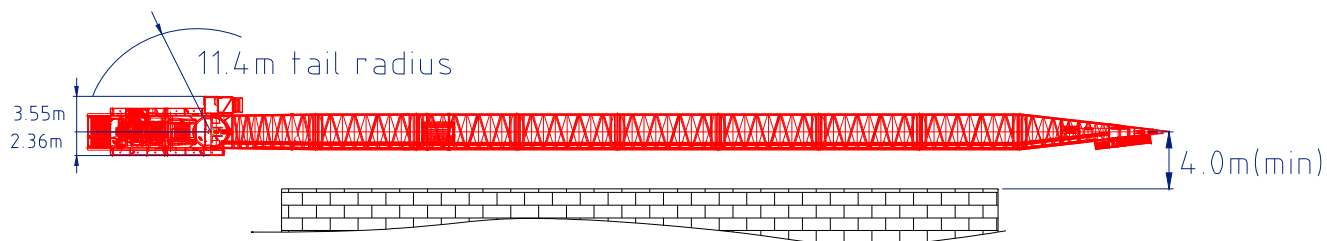











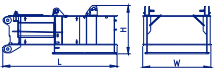
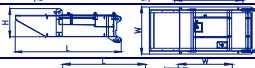
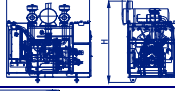

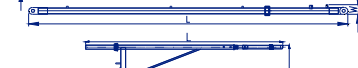

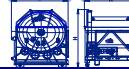

OUT OF SERVICE CONFIGURATION

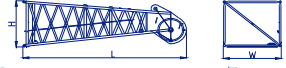
Boom Length (m)	Minimum weathervaning*	
	Radius (m)	Angle (°)
82.6	20.0	76.3
73.4	22.5	72.6
64.2	25.5	67.1
55.0	29.0	58.8
45.8	34.5	42.1
36.6	35.0	22.5

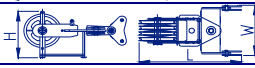
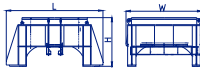
\*: MINIMUM WEATHERVANING POSITION IS BASED ON A WIND SPEED OF 20 m/s OR BOOM FLOAT AT 25 m/s

# M1280D TRANSPORTATION & ERECTION

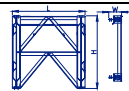
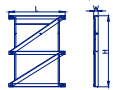

ITEM	QTY	DESCRIPTION	LENGTH L (mm)	HEIGHT H (mm)	WIDTH W (mm)	WEIGHT PER ITEM (kg)	
1	1	SPLIT DECK-FRONT (INCL. SLEW DRIVE, PINS & HANDRAILS)		6130	2745	3796	17207
2	1	SPLIT DECK-REAR		7400	2190	3796	11440
3	1	POWERPACK (INCL. 850L OF OIL)		3245	3695	2201.68	6092
4	2	MAST FRONT LEG		15659	1921	1034	6090
	1	MAST HEAD		1580	1503	1144	1522
	2	MAST BACK LEG		14671	352	390	2046
	2	BUFFER (2 PARTS)		5937	224	1779	344
		MAST ASSEMBLY (INC. SHEAVES, HEAD PIN, LADDERS, BUFFER AND PLATFORMS)					19221
5	1	CABIN & PLATFORM ASSEMBLY		3538	3900	1788.8	2288
6	1	MAIN HOIST WINCH ASSY (EMPTY DRUM)		2785	3337	2683.2	16281
7	1	AUX. HOIST WINCH ASSY (EMPTY DRUM)		1817	2062	1612	3902
8	1	LUFF WINCH ASSY (EMPTY DRUM)		2370	2481	2080	5958
9	1	BOOM BOTTOM 9.1m (INC. WALKWAY&PINS)		9323	3196	3744	2582
10	1	BOOM TOP 9.1m (Without Fly) (INC. DEFLECTOR, SHEAVES & PINS) (PENDANT & PLATFORM)		10138	3237	3744	6509
		BOOM TOP 9.1m (With Fly) (INC. DEFLECTOR, SHEAVES & PINS) (PENDANT & PLATFORM)		12635	3237	3744	7283
11	7	BOOM EXTENSION 9.2m AND PENDANT BARS (BRIDLE PLATFORM 443 kg)		9336	3196	3744	3450 (3910)
14	1	BRIDLE		2867	1447	1625.52	2668
15	1	SLEW MOUNT (INCL. PLATFORMS 760Kg)		4795	2584	3909.36	15714
	1	SLEW RING(INCL. BOLTS)		3404 DIA	200		2930
	1	MONORAIL Total		3440	632	1075.36	1060 20492
16	1	EXTERNAL CLIMBER		11745	2000	4505	33280
17	1	MONORAIL		7318	2084	1048.32	3372
18	15	COUNTER WEIGHT		4410	100	3236	7831
19	1	HOOK - 3/2 FALL (150/100T)		3250	470	1456	4680
20	1	HOOK - 1 FALL (16T)		1493	400	416	514
21	2	MAIN PANEL		3600	4000	672.88	4067
	2	SIDE PANEL		2800	3940	224.64	804
	1	DIAGONAL BRACE		3868	150	156	110
		TOWER SECTION (INC. LADDER, HAND RAIL, PLATFORM)		3600	4006	3744	10246
22	1	HOIST ROPE (Ø54mm) @ 14.15kg/m			400m		5886
23	1	FLY ROPE (Ø32mm) @ 4.95 kg/m			300m		1544
24	1	LUFF ROPE (Ø42mm) @ 8.56 kg/m			275m		2448