



LaserControl Micro Compact NT



Tool Measurement



NT Technology



Tool Breakage Detection



Tool Length Measurement



Tool Radius Measurement



Tool Form Measurement



Tool Form Monitoring



Single Cutting Edge Monitoring



RunoutControl



ToolTipControl



GrindControl



MicroWearControl



Axes Compensation

LaserControl Micro Compact NT

BLUM
focus on productivity



LaserControl Micro Compact NT | Non-contact tool setting system for machine tools

Extremely precise support system for tool setting and monitoring under harshest conditions

- Tool setting and monitoring at nominal spindle speed
- Highest absolute accuracy due to focused laser beam
- 100 % process reliability due to patented NT-Electronics
- Blum pneumatic unit and shutter system provide superior protection
- Pre-aligned for easy mounting
- Programmable by integrated microprocessor

Your benefit:

- Increased productivity and production quality
- No subsequent damage due to tool breakage
- Reduced set-up time
- Unmanned operation
- Reduced scrap rate

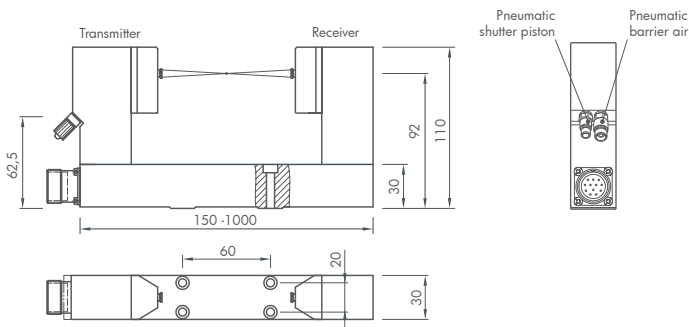

Support systems provide highest precision even with micro-tools



Fast detection of micro-wear at the cutting edge



Non-contact monitoring of all kind of tool geometries



Absolutely reliable – patented NT-Electronics and intelligent Blum protection system

Technical data

| | |
|-------------------------------|---|
| Laser safety classification | Class 2 acc. to IEC60825-1, 21 CFR 1040.10 |
| Laser type | Visible red light laser 630 - 700 nm <1 mW |
| Protection class | IP68 |
| Power supply | 24V DC / 160 mA |
| Inputs/Outputs | 24V DC 0 - 5 DC analogue output* |
| Repeatability | Δ transmitter / receiver <30 mm: 0,1 μ m 2 σ ** Δ transmitter / receiver <1.000 mm: 1,0 μ m 2 σ ** |
| Minimum tool diameter | Δ transmitter / receiver <30 mm: 5 μ m ** Δ transmitter / receiver <1.000 mm: 125 μ m ** |
| Test speed (spindle) | Up to 200.000 rpm |
| Storage/Operating temperature | -10 °C ... +70 °C +5 °C ... +45 °C |

* Option

** Depending on installation situation, stability of fixation, distance and measuring mode

BLUM
focus on productivity

**Blum worldwide
Service & Support**

More than 40 subsidiaries
and service offices.

www.blum-novotest.com

Blum-Novotest Ltd.

33 Townfields
Lichfield, Staffordshire
WS13 8AA, United Kingdom

Phone: +44 1543 257111

Fax: +44 1543 251746

E-Mail: info@blum-novotest.co.uk

Blum LMT, Inc.

4144 Olympic Boulevard
Erlanger, KY 41018
USA

Phone: +1 (859) 344 6789

Fax: +1 (859) 344 6799

E-Mail: solutions@blumlmt.com