

**RACING SUPER-AUTOMATIC TILT BACK
TYRE CHANGER WITH DUAL ASSIST ARM**

**DEMONTE-PNEUS SUPER-AUTOMATIQUE RACING
AVEC BRAS D'APPOINT A DOUBLE FONCTION**

S 228 Pro

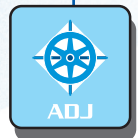
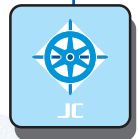
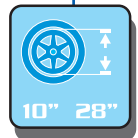

* Version available upon request / Version disponible sur demande

S 228 Pro



STANDARD FEATURES - DONNEES TECHNIQUES

Rim clamping from outside <i>Blocage jante de l'extérieur</i>	10" - 26" *
Rim clamping from inside <i>Blocage jante de l'intérieur</i>	12" - 28" *
Max. tyre diameter <i>Diamètre maxi. roue</i>	1100 mm (43")
Max. tyre width <i>Largeur maxi. roue</i>	415 mm (16")
Bead breaker cylinder force at 10 Bar <i>Force vérin décolleur à 10 Bar</i>	30800 N
Operating pressure <i>Pression de service</i>	10 Bar (145 Psi)
Power supply <i>Alimentation</i>	220V - 1ph/2 speed
Motor power <i>Puissance moteur</i>	0,8 / 1,1 kW (3ph)
Rotation speed <i>Vitesse de rotation</i>	7 - 14 rpm
Pre-set tyre inflating pressure <i>Pression de gonflage maxi.</i>	3,5 Bar (50 Psi)
Net weight <i>Poids net</i>	360 kg

* By adjustable jaws

* Par griffes de blocage réglables

DIMENSIONS - DIMENSIONS

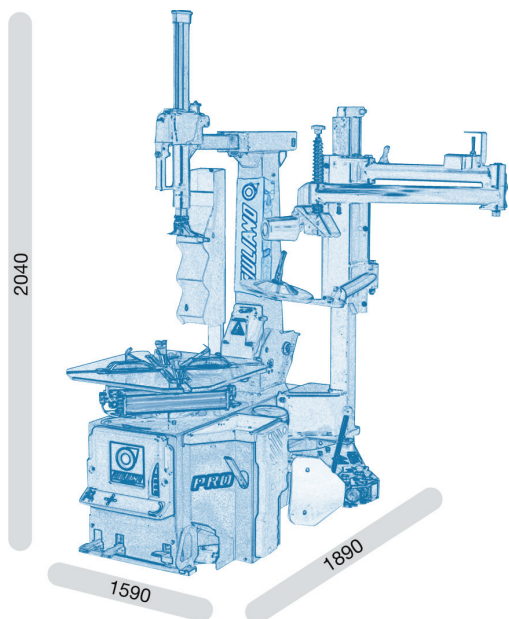

STANDARD ACCESSORIES - ACCESSOIRES STANDARD



For high volume tyre shops, servicing racing, run flat and UHP tyres.

Pour les ateliers gérant des volumes élevés et spécialisés sur les pneus Racing, Run Flat et Uhp.

FUNCTIONS - CARACTERISTIQUES

Tilting tower, sliding horizontal arm with Ø 41 mm operating arm
Bras vertical basculant, bras horizontal coulissant avec bras porte outil hexagonal de Ø 41 mm

Bead breaker double effect Cylinder Ø 200 mm
Vérin détalonneur de Ø 200 mm à double effet

Reinforced Chassis and Tower
Châssis et bras vertical renforcés

Tabletop thickness 14 mm w/adjust. jaws (Giuliano Patent)
Plateau centreur ayant une épaisseur de 14 mm avec griffes de blocage réglables (brevet Giuliano)

Fitting head designed for both standard and low profiled tyre applications
Tête de montage conçue pour les pneus standards ainsi que pour les pneus à profil rabaisé

Double rotation speed by pedal
Double vitesse de rotation par pédale

Tyre inflation by pedal (standard)
Dispositif de gonflage par pédale (standard)

Adjustable bead breaker shovel angle
Réglage de l'angle de la pelle décolle-talon

Equipped with HP2 dual assist arm (standard) and storage box
Equipé standard du bras d'appoint avec double fonction HP2 et de boîte de rangement outils

Suitable for Tubeless tyre bead seating system (optional)
Système de gonflage Tubeless GUN (en option)

"Easy Access" extractable pedal box for quick service
Pédalier amovible et facilement accessible pour les opérations d'entretien rapide

PO System, Giuliano patent, for granting no bead breaker shovel stuck into the rim during bead breaking operations
Dispositif « PO System » permettant d'éviter le coincage de la pelle décolle-talons dans la jante (brevet Giuliano) pendant le décollage du talon

Robotic pipe for operating arm positioning/lock
Système robotisé pour le positionnement/blocage du bras opérateur



Profession: Passion

Giuliano Industrial S.p.A: Via Guerrieri, 6 - 42015 CORREGGIO (RE) ITALY
Tel. +39 0522 731111 - Telefax +39 0522 633109 - E-mail: info@giuliano-automotive.com
Internet: www.giuliano-automotive.com

Since 1976

