

TITON 500



POWERFUL • PRECISE • FAST





FEATURES AND BENEFITS

- compressor air volume matched to operate a 4" and 5" DTH hammer at high pressure
- spacious FOPS/ROPS cabin with joy-stick controls and excellent visibility for operator comfort
- mobility through superior gradeability and heavy duty oscillating tracks
- two-speed tramming mode with 4.0 km/h maximum speed
- solid excavator type frame for longer life and rig stability
- CAT C-10 engine for power and emission control standards
- 5 meter drill pipes for productivity and optimal rig stability
- integrated dry dust collector
- easy access to service points through 3 plus 1 door system
- compact unique design for transportability and bench mobility
- angle and toe-hole capability



POWERFUL • PRECISE • FAST



The **TITON 500** is a new member in the Sandvik BPI range of DTH drilling rigs. It has been designed to meet the most versatile requirements of mining and quarrying applications and is best suited for 105 - 152 mm hole sizes. Transportability and high compressor output makes it a flexible tool for any quarry, mine or contractor with high productivity requirements and flexible drilling needs.

The **TITON 500** matched with the Driltech Mission range of Mirror

Impact DTH hammers is the optimal drilling combination for any rock condition.

The **TITON 500** represents over 40 years of experience of DTH drilling rig designing which has been translated into a long list of product improvements like: easily removable fuel tank, unique ground stinger, maximum interior air-flow for cooling, adjustable collaring mode, "best-seat-in-the-business", to name just a few. All included in the standard unit.



TITON 500

POWERFUL · PRECISE · FAST

Technical Specifications

Drilling data

Optimal drill range	mm	105 - 152
Drill tube diameter	mm	89, 102 or 114
Drill tube length	mm	5000

Power pack and compressor

Diesel engine		CAT C-10
Screw compressor	stage	double
Air volume	m ³ /min	22
Air pressure	bar	24

Cabin

FOPS II / ROPS

Chassis

Tractive force	kN	126
Gradeability	%	70*
Tramming speed	km/h	2.8 / 4.0
Crawler oscillation	degrees	+/- 10

Magazine

Type		revolver
Capacity (89 mm)		7 + 1
Capacity (102 mm)		6 + 1
Capacity (114 mm)		5 + 1
Hole depth	m	40 / 35 / 30

Transport Dimensions

Length	mm	11 434
Width	mm	2 480
Height	mm	3 125
Weight	kg	19 500

*please consult local safety regulations for use of winch in inclined terrain

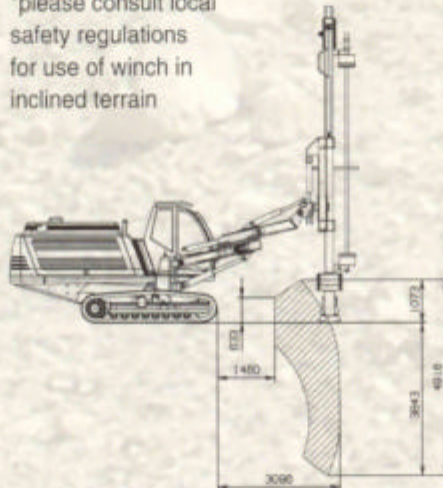
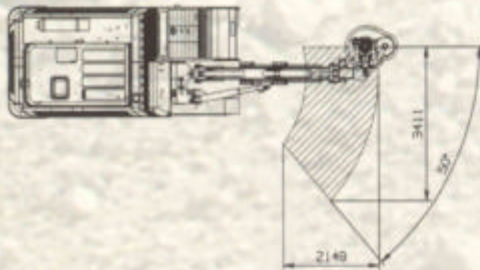

Please consult your local representative for more features and detailed specifications.

Authorised Dealer:

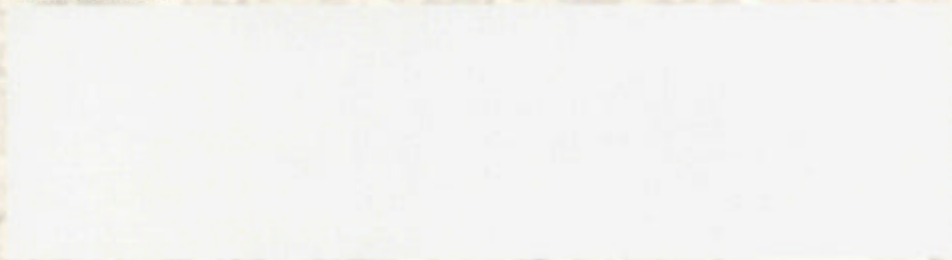

SANDVIK BPI
Bohrtechnik GmbH & Co KG
Alpinestr. 1 · A-8740 Zeltweg / Austria

Phone: +43 3577 755 - 0
Fax: +43 3577 756 - 777

E-mail: sales.bpi@sandvik.com



Sandvik Mining and Construction is one of the three business areas of Sandvik Group. We are the world's leading supplier of drilling and excavation machinery, equipment and tools for mining and construction industries. The overall net sales of SMC are over USD 4 billion. Sandvik Mining and Construction Business Sectors are Sandvik Tamrock, West Alpine Eirco-Driltech Mission and Sandvik Materials Handling.

Photo: Sandvik - Gunnar Engström