

Design for low power consumption led driver IC package

Shrikant Shrivastava¹, Himanshu Nautiyal²
Sagar Institute of research and technology

Abstract- The Light-Emitting Diode (LED) driver is an important part of Visible Light Communication (VLC) systems. The main challenge of the VLC LED driver is to offer a high data transmission rate with high power efficiency. This paper presents the design of a white light LED driver that combines the LED lighting with VLC technology. The proposed LED driver uses linear current regulation and controls the AC current signal and the DC current through a single power device for the purposes of high speed, high efficiency and high integration. It also can support the modulation format of orthogonal frequency division multiplexing (OFDM). In addition, this work presents an impedance reduction technique to enhance the bandwidth of the LED driver. And a first-order pre-equalizer is utilized to enhance the electron-optical-electron (E/O/E) bandwidth in the VLC system due to the bandwidth limitation of the phosphor converted LED. The VLC LED driver is fabricated in a standard 0.5 μm CMOS technology with chip area 1540 μm × 1250 μm. It is available in a standard SOP-16 pin package. The experimental results show that the optical modulation bandwidth of 10.9 MHz has been achieved with the forward biased LED current of 350mA. By using the OFDM data modulation scheme, the data rate of 50 Mb/s is demonstrated.

I. INTRODUCTION OF LINEAR CURRENT MODULATION

As shown in Figure 1, for the purpose of an accurate driven current I_{LED}, the driver is under close-loop control, which is generated by connecting the control IC to the power MOSFET M1 and the current sense resistor R1. By the way, VCS is the driver's output voltage and the driving current is equal to VCS/R1. Because of the linearly first-order relationship of I_{LED} and VCS, the driver with linear current modulation has been

achieved. Furthermore, the linear driving circuit also realizes the purpose of controlling the DC and AC signal through a single power device M1. The control IC's output voltage VCS is equal to DC signal plus data signal. In other words, the LED's driving current I_{LED} involves the command of lighting and Communication. So the LED driver adds the VLC technology into solid-state lighting successfully.

A small-signal model of the LED driver is shown in Figure 2, its output impedance R_O is over kilo meter, and the LED string's impedance is about a dozen to dozens ohm. So the entire driving circuit can be seen as a voltage control current source, which is used to control the LED's DC and AC current with linear modulation method for the purposes of lighting and communication.

II. STAGE OF POWER DEVICE

The main purpose of the power device stage is to supply high power current to LED, it consists of the power MOSFET and current sense resistor. However, the high power current usually brings about the large equivalent capacitance at the gate of power MOSFET. Hence, not only the loop's bandwidth of LED driver will be decreased but also the additional power loss of control IC will be increased due to the more current is needed for driving the power MOSFET. Moreover, these problems will also cause another disadvantages of the system such as low data rate, low efficiency, and low linearity.

The right side driver in Figure 3 is to solve these problems. The impedance reduction technique in this work is to decrease the equivalent capacitance at the gate of the power MOSFET. As shown in Figure 3. There are two LED drivers, which are both consisted of the white light LED (MX-3) of Cree Corporation and n-MOSFET (Si3456DDV) of Vishay Corporation.

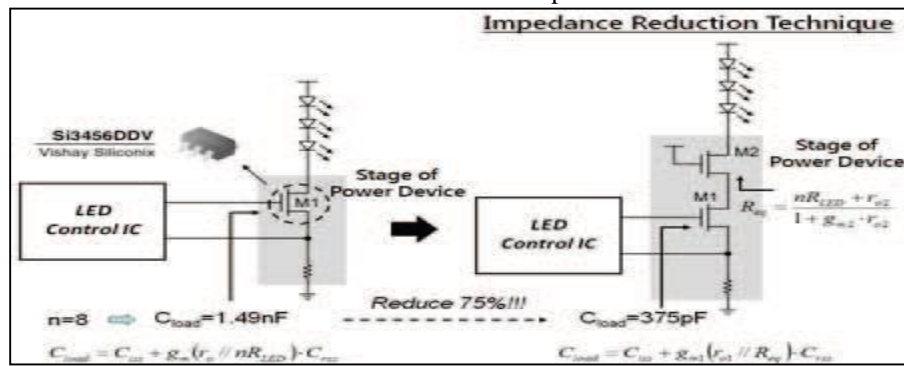

Fig.1: Comparison of two architectures.

and this capacitance comes from the miller effect on the small-signal input capacitance C_{iss} and the inverse communication capacitance C_{rss} . The quantity of miller capacitor is depended on the output impedance of power MOSFET's drain. However, the output impedance of power MOSFET's drain is increased by the number of LEDs, and then it will increase the equivalent capacitance at the gate of the power MOSFET as well. As shown in the left side of Figure 3. When the control IC is driving eight LEDs with 350 mA, the equivalent capacitance at the gate of the power MOSFET is 1.49 nF. Hence, the driver's electric bandwidth is limited by this large equivalent capacitance. To solve the problem comes from the large equivalent capacitance due to the output impedance of power MOSFET's drain is increased by the number of LEDs, the right side driver discloses the impedance reduction technique. Its output impedance of power MOSFET's drains decreased by a factor of $1+g_{mro}$ with the cascade power MOSFET. Hence, the driver's equivalent capacitance at the gate of the power MOSFET can be decreased from 1.49 nF to 375 pF, and it's bandwidth can be extended as well. In brief, this work utilizes the impedance reduction technique to achieve a large bandwidth, high driving current, and high efficiency driver.

III. CONTROL IC DESIGN

The paper will make a detail introduction to control IC of the driver in this section. It is for the purpose of combining the DC current for lighting with AC current for data transmission through a single power device. The control IC of the driver not only can provide a large driving current but also a high speed data transmission with its wide bandwidth. The function blocks of the driver are shown in Figure 4, which are error amplifier, voltage adder, voltage regulator and bias circuit.

❖ **Error Amplifier:** For the purpose of high gain, high driving capability and high linearity, the error amplifier of the control IC is realized by a folded cascade amplifier with class AB output stage. [5], because the feedback voltage on the current sense resistor is reference to ground and in the low voltage range, the p-MOSFET differential input is suitable for the folded cascade amplifier. The entire gain of error amplifier is equal to the gain A_1 of folded cascade amplifier multiplied by the gain A_2 of class AB output stage.

The feedback loop of the error amplifier is compensated by the cascade miller compensation, and its small-signal analysis is shown in Figure Compare with general miller compensation, the no dominant pole in is higher than that in the general miller Compensation. By multiplying an additional value of C_c/C_{nd} , where the C_c is bigger than C_{nd} , the characteristic of the loop will be more stable at high frequency because of this higher pole. Furthermore, the compensation

capacitor is connected to low impedance at its left side, which will make the total harmonic distortion of the error amplifier better. When the power device stage is taken into account in the whole driver's simulation, the 32 MHz electric bandwidth is achieved in the common mode range of 0 V to 3 V, and the entire current consumption of the control IC is 14 mA.

❖ **Voltage Adder:** The purpose of the voltage adder is to combine the DC lighting signal VLD with AC signal VIS for data transmission, and to provide the proper signal to the error amplifier after it., the voltage VX is equal to $(VLD + VIS)/2$ because the two resistances at the input nodes, VLD and VIS, are the same. And the output voltage Vmix will be equal to $(1+\square)(VLD + VIS)/2$ after the signal VX is amplified by the non-invert amplifier A1. By the way, if the value of \square is 1, the Vmix will be equal to VLD + VIS.

IV. PRE-EQUALIZER

Even through the 32 MHz electric bandwidth of LED driver is achieved with impedance reduction technique, the optical band wid this limited by the phosphor-converted LED which needs a long response time to convert an electric signal to a light signal. In order to solve this problem, the pre-equalizer is presented to compensate this bandwidth limit due to the phosphor-converted LED. [7] The pre-equalizer is the first-order architecture, which is constructed of R1, C1 and R2. Its transfer function is shown as below.

❖ **Advantage and merits:**

1. LED Brightness and Color Temperature: LED Brightness

The concept of the brightness of visible light from an LED is fairly easy to understand. Assigning a numerical value to the perceived brightness of an LED's output can simply be measured in units of luminous flux density, called candelas (cd). The total power output of an LED is a measurement of the amount of Lumens (lm). It is also important to understand that average forward LED current determines the brightness of an LED.

V. RESULT AND SIMULATION

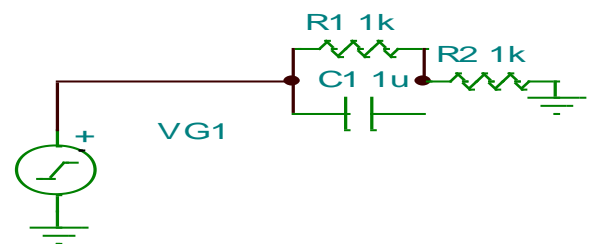

Fig.2: First-order equalizer

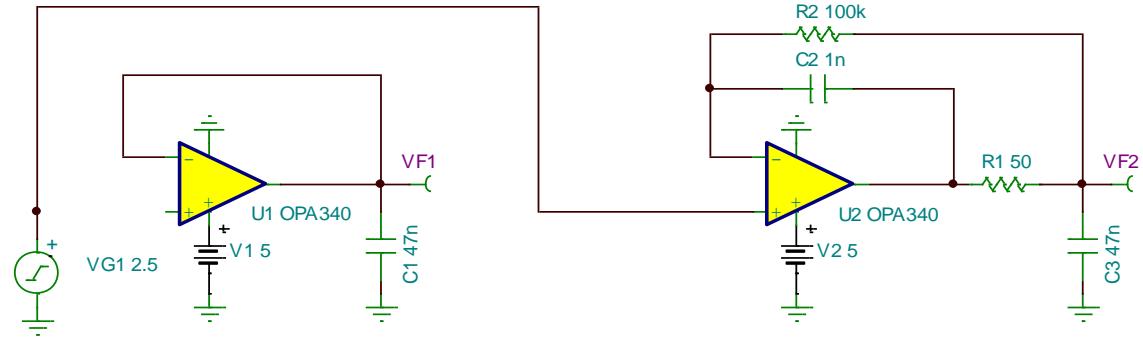

Fig.3: Small-signal analysis of miller compensation.

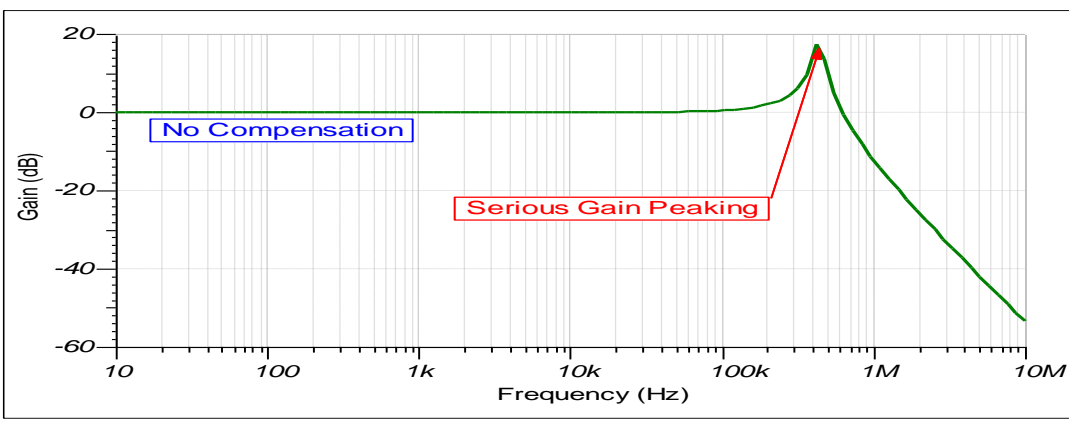

Fig.4: Gain Vs Frequency Graph.

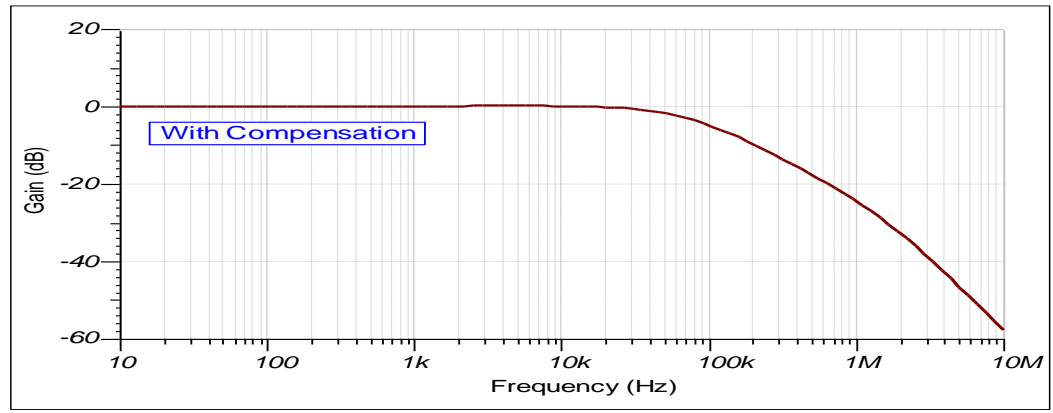

Fig.5: With compensation

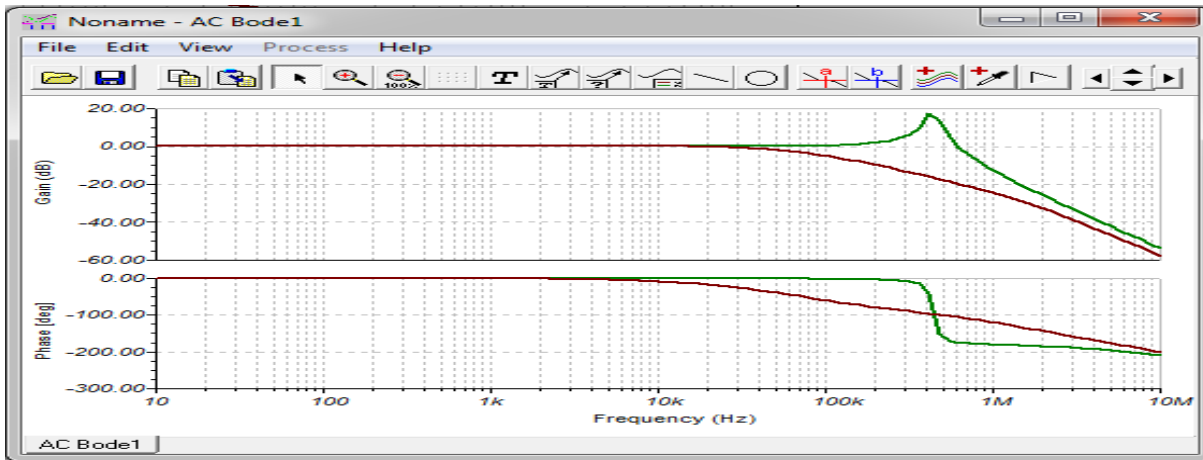

Fig.6: Comparison between Equalizer and without equalizer output

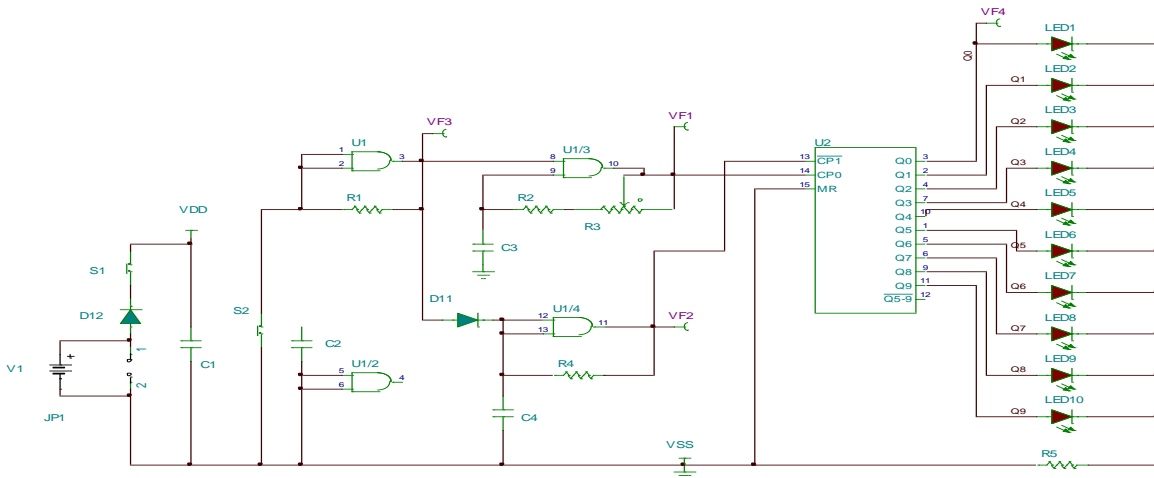

Fig.7: LED Driver circuit.

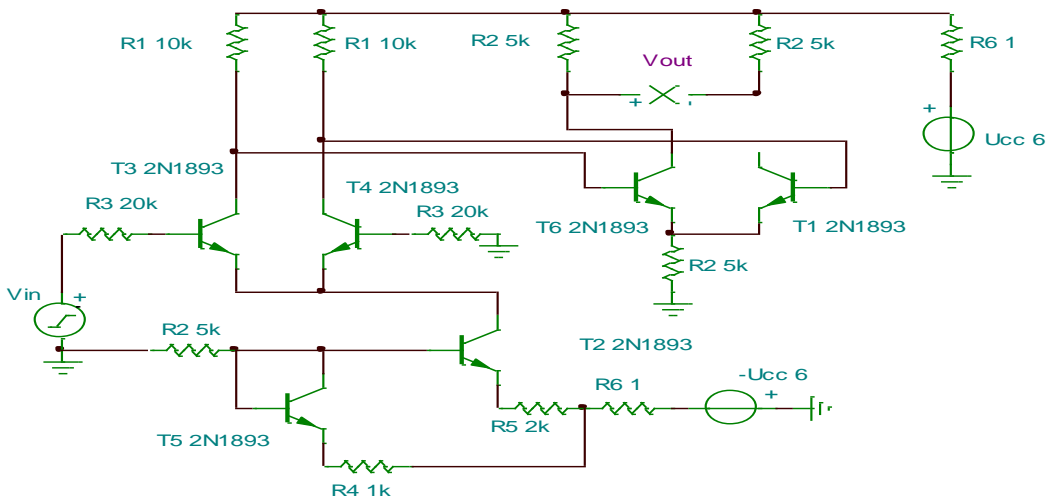

Fig.8: Output waveform.

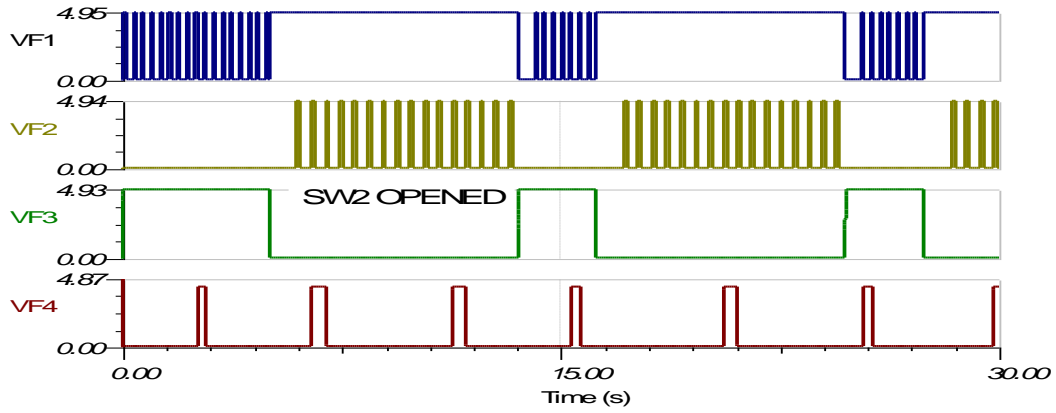

Fig.9: Differential amplifiers.

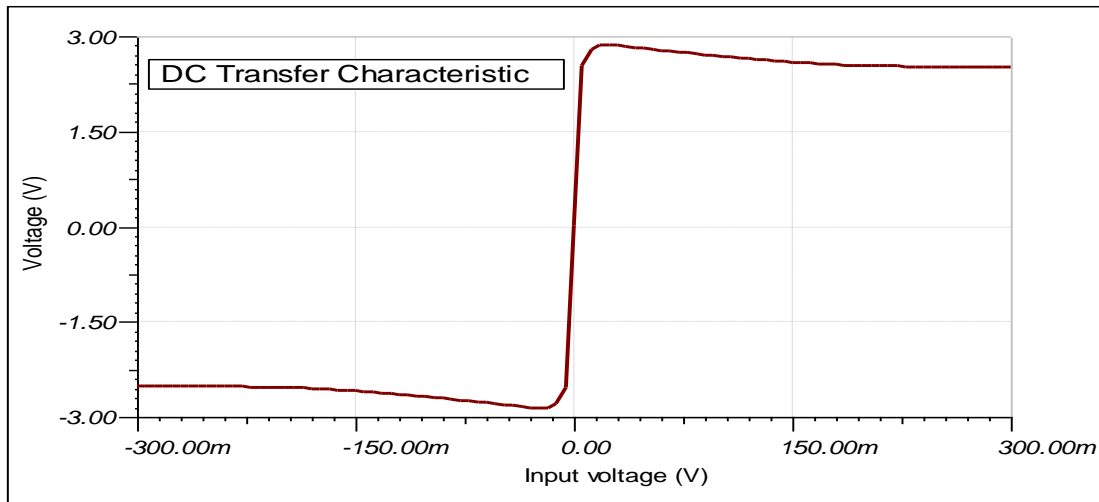

Fig.10: Transfer characteristics.

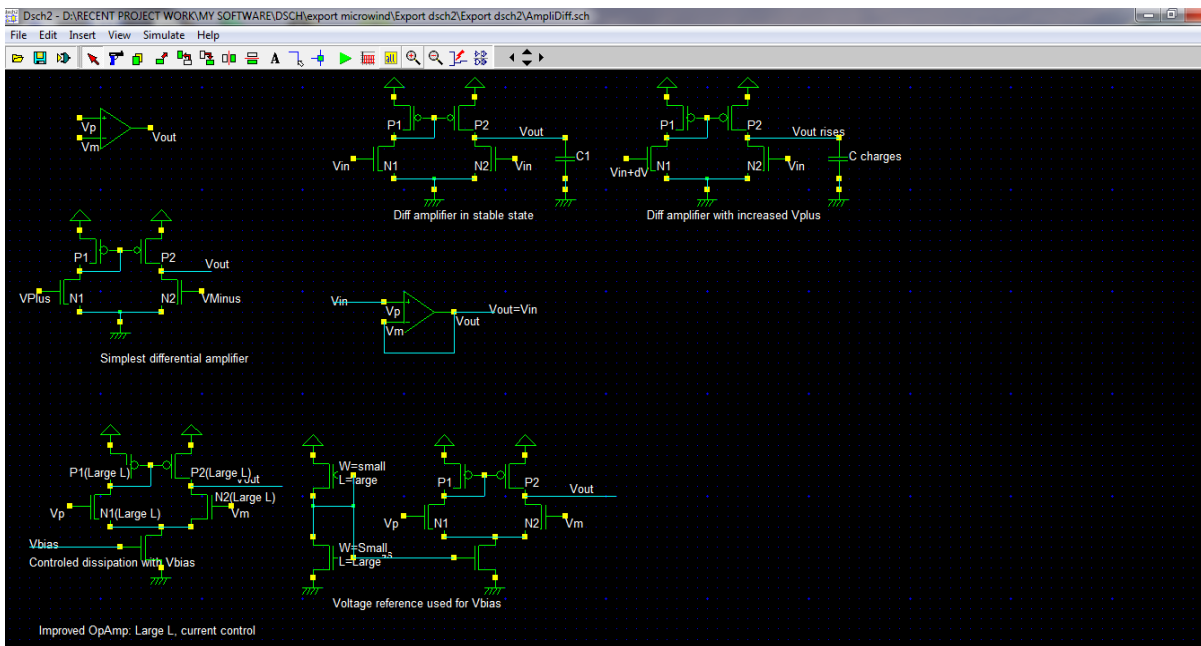

Fig.11: Differential amplifier.

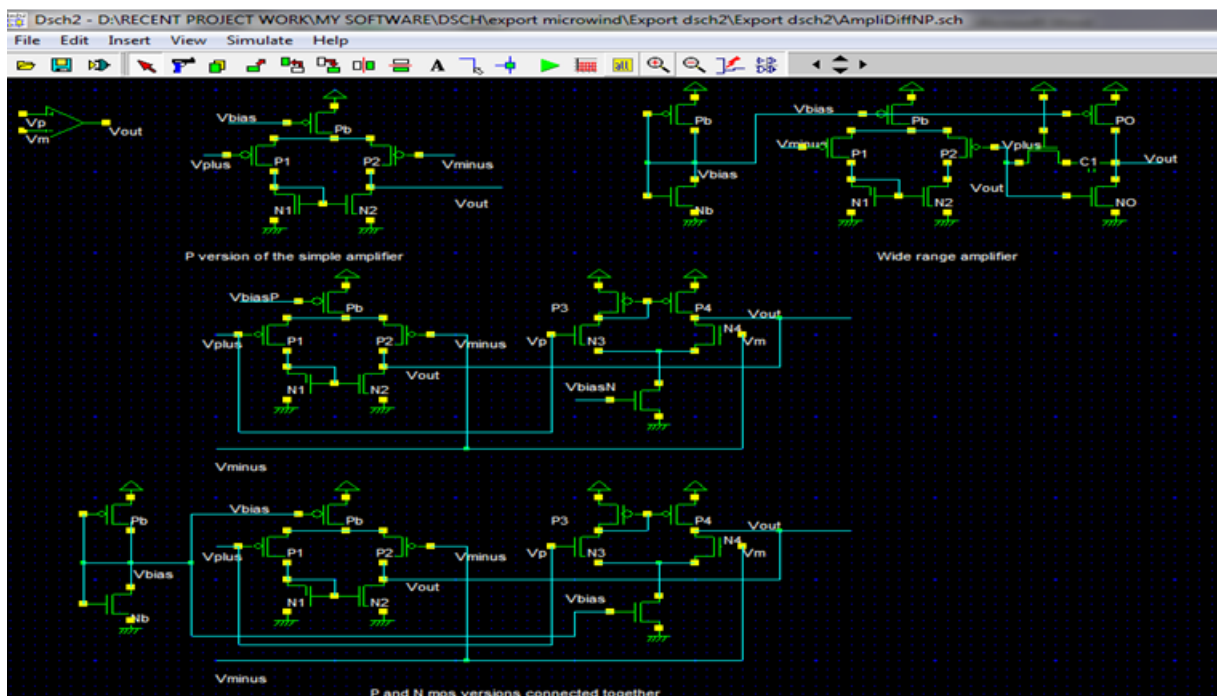

Fig.12: LED driver all schematic cell.

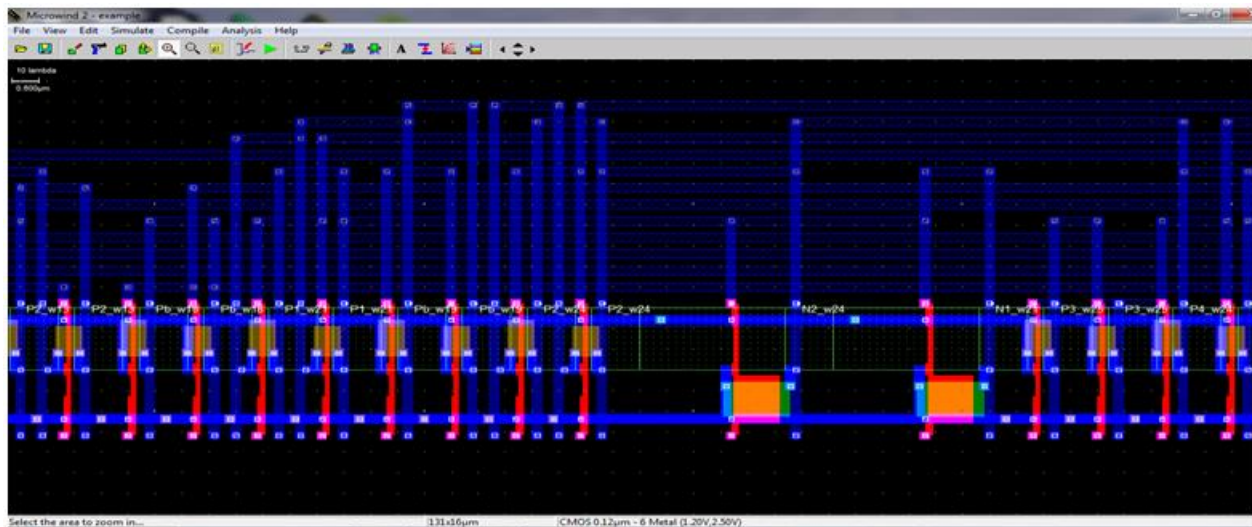

Fig.13: Differential amplifier layout.

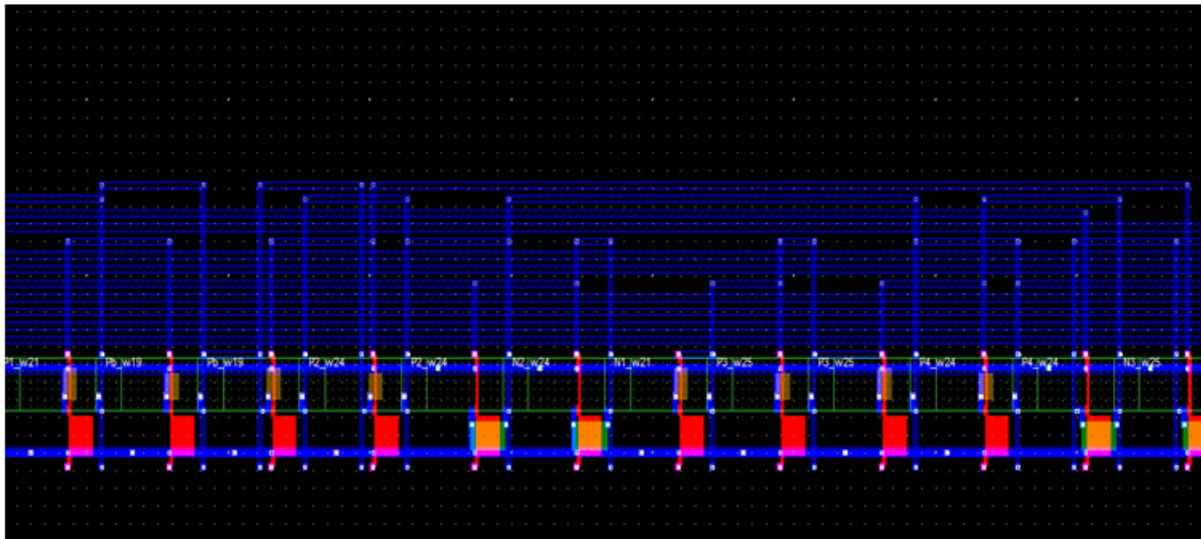

Fig.14: All LED driver layout.

VI. CONCLUSION

The LED driver in this paper combines the function of lighting with VLC technology. The proposed LED driver uses linear current regulation and controls the AC and DC current signal through a single power device for the purposes of high speed, high efficiency and high integration. In addition, this work utilizes an impedance reduction technique to enhance the electric bandwidth of it. And a first-order pre-equalizer before control IC is utilized to enhance the E/O/E bandwidth which is limited by the phosphor-converted LED original. This VLC LED driver is fabricated in a standard 0.5_μm CMOS technology with chip area 1540_μm × 1250_μm. It is available in a standard SOP-16 pin package. The experimental results show that the optical modulation bandwidth of 10.9 MHz has been

achieved with the forward biased LED current of 350 mA. By using the OFDM data modulation scheme, the data rate of 50 Mb/s is demonstrated.

VII. REFERENCES

- [1]. H. Le-Minh, D. O'Brien, G. Faulkner and L. Zeng, "100-Mb/s NRZ Visible Light Communications Using a Post-equalized White LED," *IEEE Photon. Technol. Lett.*, vol. 21, pp.1063-1065, Aug.2009.
- [2]. C. W. Chow, C. H. Yeh, Y. F. Liu and Y. Liu, "Improved modulation speed of the LED visible light communication system integrated to the main electricity network," *Electron. Lett.*, vol. 47, pp.867-868, July.2011.

- [3]. H. Le-Minh, D. O'Brien, G. Faulkner and L. Zeng, "80 Mbit/s VisibleLight Communications using pre-equalized white LED," Proc. ECOC,2008, pp.1-2.
- [4]. H. Le-Minh, D. O'Brien, G. Faulkner and L. Zeng, "High-Speed VisibleLight Communications Using Multiple-Resonant Equalization," IEEEPhoton. Technol. Lett., vol. 20, pp.1243-1245, July.2008.
- [5]. R. Hogervorst and J. H. Huijsing, Design of Low-Voltage, Low-PowerOperational Amplifier Cells, Kluwer Academic Publishers, 1996.
- [6]. Imre Knausz. (2004) [online]. Available:www.knausz.com/files/opamp_final_paper2.pdf
- [7]. H. Li, X. Chen, B. Huang, and D. Tang, "High Bandwidth Visible LightCommunications Based on a Post-Equalization Circuit," IEEEPhotonics Technology Letters., vol. 26, pp.119-122, Jan.2014.