

## Dryer Vent Policy

February 24, 2021

Rev 2021-2

Exceptions to this Policy must be approved, in writing, by a majority of the Trustees. This policy is effective as of the above date and replaces and supercedes all prior revisions of the above captioned policy.

### **i. Revision History**

Revision		Date
2010-4	Initial Release	November 16, 2010
2013-5	Added specifications for exterior vent hood type and vent locations and alignment on buildings per SECTION IV(14)	June 14, 2013
2021-2	Added <b>Installer NOTICE – Unit Variations</b>	February 24, 2021

<b>1. Dryer Vent Policy Purpose</b>	<b>1</b>
<b>2. Dryer with Vent to Exterior</b>	<b>2</b>
<b>3. Dryer with NO Vent to Exterior</b>	<b>2</b>
<b>4. Dryer Vent Modifications or Additions</b>	<b>2</b>
<b>5. Dryer Vent Plans, Installer NOTICE – Unit Variations</b>	<b>4</b>
<b>6. Dryer Vent Plan Overview</b>	<b>5</b>
<b>7. Notes to Plan Drawings</b>	<b>6</b>
<b>8. Appendix A – Appurtenances</b>	<b>8</b>
<b>9. Appendix B – Vent Plan Drawings</b>	<b>16</b>

### **I. Dryer Vent Policy Purpose**

1. Establish consistent application of requirements for dryer vent modifications or additions within Natick Green.
2. Limit financial exposure of Natick Green Condominium Trust in regard to dryer vent modifications within Natick Green.
3. Limit any negative Insurance impact due to dryer vent modifications within Natick Green upon the “Master Fire” and like policies purchased by Natick Green Condominium Trust from time to time.
4. Provide approved plans and specifications (the “Plans”) for venting all dryers that are required to be vented per the Massachusetts Building Code revised as of January 2010.
5. Provide for visual constancy in placement of vent outlets to help maintain Natick Green property values and community aesthetics.

## Dryer Vent Policy

February 24, 2021

Rev 2021-2

### II. Dryer with Vent to Exterior

1. Units on Post Oak Lane and the Units at 9 Silver Hill Lane, 11 Silver Hill Lane, 50 Silver Hill Lane and 52 Silver Hill Lane are vented to the exterior by design at the time of original construction.
2. Dryer vent maintenance, and all costs associated therewith, is the responsibility of the Unit Owner.
3. Dryer Vents shall be cleaned at intervals not to exceed 24 months. Evidence of such cleaning shall be provided to Natick Green in a timely manner.
4. Violation of these Section II requirements may subject the Unit Owner to fines.
5. Modifications per Section IV.

### III. Dryer with NO Vent to Exterior

1. Dryers shall be:
  - a. "listed and labeled condensing (ductless) clothes dryers" (MA 780 CMR 6501)
  - b. approved by the Building Inspector for the Town of Natick.
2. No dryer may be vented into any Common Area or space including attics.
3. Operation of any dryer using a "dryer vent kit" to terminate the dryer vent output line is a violation of the Massachusetts Building Code and the Rules and Regulations of Natick Green Condominium.
4. Violation of these Section III requirements may subject the Unit Owner to fines.
5. Modifications per Section IV.

### IV. Dryer Vent Modifications or Additions

#### Plans/Approvals

1. Installation or modification of dryer venting that conforms with the Plans herein may be commenced upon written notice to Natick Green which includes the following:
  - a. Contractor information
  - b. Contractor Insurance certificate acceptable to Natick Green Condominium
  - c. Building Permit Issued by the Town of Natick
2. NO FIREWALL PENETRATIONS are permitted in any attic or otherwise.
3. NO ROOF PENETRATIONS are permitted except in limited cases as may be specified in the Plans that are part of this Policy.
4. No vent modification or addition shall exhaust into any enclosed Common Area or space.

## Dryer Vent Policy

February 24, 2021

Rev 2021-2

### IV. Dryer Vent Modifications or Additions (cont'd)

5. No vent shall include any branch or “wye” connection.
6. All costs of any modification or addition shall be borne by the Unit Owner including any damages to Common Area elements or other Units.
7. The Unit Owner shall be billed for Maintenance time at standard rates.
8. Unit Owner is responsible to deliver a signed-off copy of the Building Permit to Natick Green within 10 days of completion of venting work.
9. All sheetrock penetrations shall be completely sealed with plaster/gypsum compound.
10. All exterior wall penetrations shall be made watertight with silicone caulk or like waterproof materials.
11. All existing utilities, ducts, ridge vents, eaves and soffits in any Common Area shall remain undisturbed and unmodified.
12. The existing building insulation “envelope” shall be maintained.
13. The placement of vent outlets shall be consistent from Unit to Unit and floor to floor in any given building to the greatest extent possible. Deviations from this requirement require approval by the Director of Maintenance, in advance.
14. Director of Maintenance shall inspect and sign off completion of any modification or addition.  
**Documented deficiencies shall be corrected at Unit Owner’s expense in a timely and workmanlike manner.**

**NOTE: Any proposed Vent Plan that deviates from the approved Plans herein shall be subject to review and approval by Natick Green and the Building Department of the Town of Natick.**

## Dryer Vent Policy

February 24, 2021

Rev 2021-2

### V. Dryer Vent Plans

- Each dryer vent installed under this Policy shall conform to the length and routing specified in the Dryer Plan (latest revision) for the appropriate Style of Unit at Natick Green being modified. For purposes of this paragraph, "Style" shall also include the available exterior exit point(s) for dryer ductwork.
- "Mirror image" units (from the Plans) may utilize the same Plan with the installation mirror imaged as appropriate.
- Dryer Vent Plans are available for the following Unit Styles:

Unit Type and Style	Quantity	Plan Number/Comment	
<u>Large 1 Bedroom 1 Bath</u>			
Style A-1 Corner/End Units Not Top Floor	8	Plan A-1	<b>Page 15</b>
Style A-2 Corner/End Units Top Floor	16	Plan A-2	<b>Page 16</b>
Style A-3 Middle Units Not Top Floor	22	Plan A-3 **	<b>Page 17</b>
Style A-4 Middle Units Top Floor	2	Plan A-4	<b>Page 18</b>
<u>2 Bedroom 1 Bath</u>			
Style B-1 End Unit Not Top Floor	22	Plan B-1 **	<b>Page 19</b>
Style B-2 End Unit Top Floor	22	Plan B-2	<b>Page 20</b>
<u>Small 2 Bedroom 2 Bath</u>			
Style C-1 Not Top Floor	10	Plan C-1 **	<b>Page 21</b>
Style C-2 Top Floor	8	Plan C-2	<b>Page 22</b>
<u>2 Bedroom 1 1/2 Bath Townhouse</u>			
Style D-1 End Units	6	Plan D-1	<b>Page 23</b>
Style D-2 Middle Units	8	Plan D-2	<b>Page 24</b>
<u>Large 2 bedroom 2 Bath (Style F)</u>	all	Vented at construction	
<u>Small 1 bedroom 1 Bath (Style G)</u>	all	Vented at construction	

\*\* Note: Electrically operated Booster Fan is required due to duct long Equivalent Length.

### **Installer NOTICE – Unit Variations**

The dryer vent routing and hardware specified in these Vent Plan Drawings represent the typical configuration for each type and location of unit.

Variations in construction details of a specific unit may require additional duct elbows or routing and potentially a booster fan.

Installations that **DO NOT MEET MASSACHUSETTS BUILDING CODE REQUIREMENTS** are subject to retrofit by the Natick Green Director of Maintenance at the sole expense of the Unit Owner.

Installers having questions or concerns regarding this Dryer Vent Policy should consult the Natick Green Director of Maintenance at 7 Silver Hill Lane, Natick, 508-655-5800.

**See Appendix B for Vent Plan Drawings.**

## Dryer Vent Policy

February 24, 2021

Rev 2021-2

### V. Dryer Vent Plans (cont'd)

4. Dryer Vent Plans under this Policy utilize components with specific characteristics to achieve acceptable safe venting performance. These Appurtenances are shown in Appendix A and include:
  - a. 4" aluminum rigid duct
  - b. 10" radius smooth finish 90 degree 4" elbow
  - c. 4" standard duct elbow
  - d. Self-adhesive metal tape
  - e. Wall Cap or Roof Cap vent hood with damper
  - f. Bird Screen (except Roof Cap installations)
  - g. 4" Flexible aluminum duct ("Transition Duct")
  - h. 4" Worm Drive Clamp
  - i. Booster Fan

### VI. Dryer Vent Plan Overview

1. Massachusetts Building Code
  - a. Maximum Equivalent Length 25' exclusive of Transition Duct to dryer
    - i. De-rate Length 5 feet for each standard 90-degree elbow
    - ii. De-rate Length 1.5 feet for 10" radius smooth finish 90 degree elbow
    - iii. Add Booster Fan if length exceeded
  - b. Duct Material
    - i. 4" Aluminum stove pipe
    - ii. Metal Tape seal of joints (no screws/rivets)
  - c. Duct Mounting
    - i. Boxed Soffit (see Figure 1) or metal strapping in attic common area
    - ii. 1/2" Sheetrock
  - d. Building Duct Exit
    - i. Weatherproof Cap with minimum 4" circular opening area
    - ii. Position of Duct Exit/Cap per SECTION IV(14)
    - iii. Silicone caulk
  - e. Booster Fan (when required by Plan)
    - i. Rated Fan for minimum 60-ft equivalent run length
    - ii. AC power off existing circuit
    - iii. Pressure Switch on-off control
    - iv. "Remote Fan" Label at Dryer location
  - f. Condensate Drain (when Booster Fan is installed)
    - i. To existing washer stand pipe drain, or
  - g. Transition Duct (Wall Vent connection to Dryer)
    - i. Flex Aluminum, 4"
    - ii. Secured with 4" Worm Drive Clamps

## Dryer Vent Policy

February 24, 2021

Rev 2021-2

### VII. Notes to Plan Drawings

(see Appurtenance documentation in Appendix A):

- (A) - 90 Degree 10" Radius Elbow, Smooth Finish = 1.5' Duct vs. std 90 Degree 4" Elbow
- (B) - Wall Cap or Roof Cap 4", with Damper, no screen
- (C) - Bird Screen  
Deflecto Supurr-Guard Louvered Vent Hood with built-in Bird and Rodent Guard, 4" diameter, or Equiv.
- (D) - Booster Fan (110V, 50W 0.5A)
- (E) - Condensate Drain (when Booster Fan is installed)  
1/4" tubing connected to drain
- (F) - "Remote Fan" Label  
Must be located within six feet of the duct connection to the Transition Duct

This dryer exhaust system is equipped with a remotely located booster fan.

- (G) - Worm Drive Clamp, 4"

#### Boxed Soffit Construction

Surrounds 4" Duct with minimum distance from ceiling/wall

**Minimum clearance from finish floor 72"**

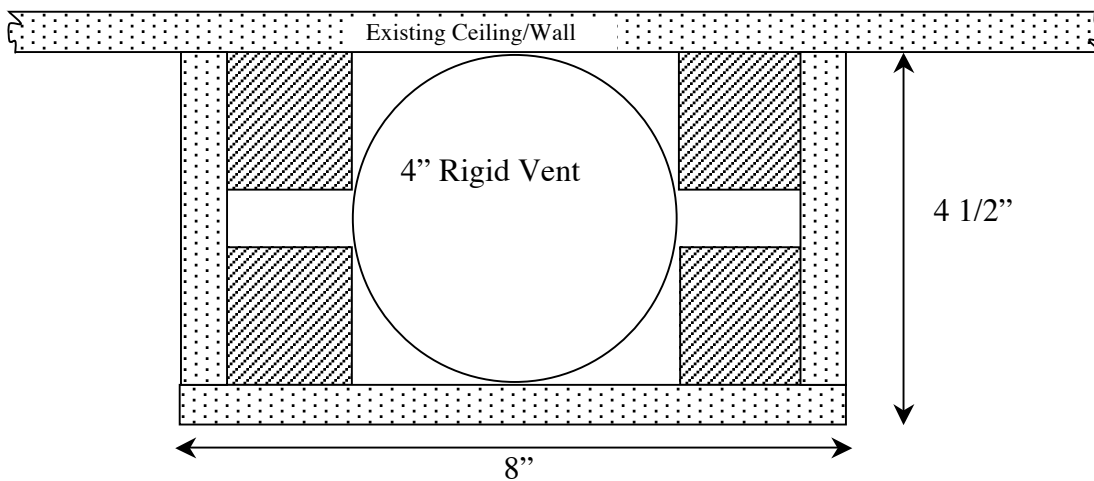

Figure 1

## Dryer Vent Policy

February 24, 2021

Rev 2021-2

### VII. Notes to Plan Drawings (cont'd)

“1<sup>st</sup> Floor” – distance from ceiling: (ceiling to dryer vertical duct connection)  
10-inch Elbow  
4' aluminum stove pipe (4")  
Ends approximately 3' off finish floor, 48" Transition Duct -  
4" flex aluminum connection to Dryer

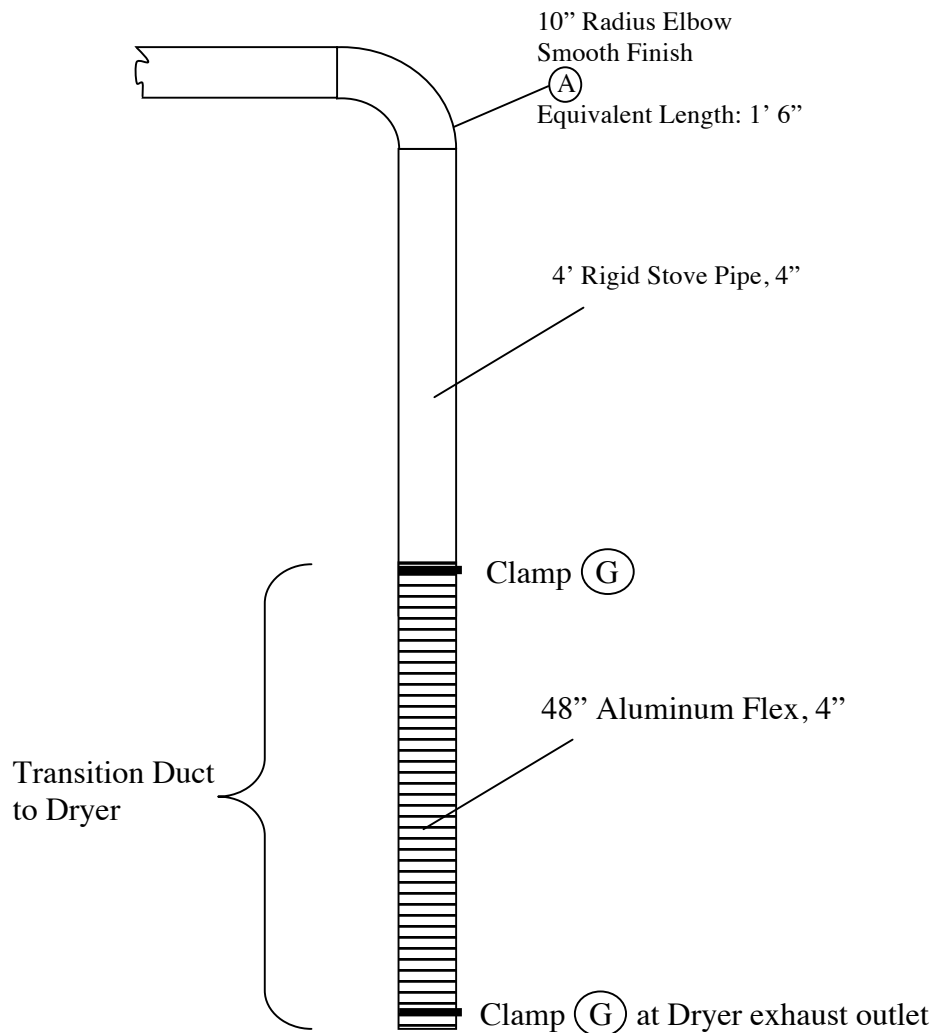

Figure 2

## Dryer Vent Policy

February 24, 2021

Rev 2021-2

### VIII. Appendix A – Appurtenances

- a. 4” aluminum rigid duct  
Standard building supply item
- b. 10” radius smooth finish 90 degree 4” elbow **Page 9**
- c. 4” standard duct elbow  
Standard building supply item
- d. Self-adhesive metal tape  
Standard building supply item
- e. Roof Cap vent hood with damper 4” **Page 10**
- f. Bird Screen (except Roof Cap installations) **Page 11**
- g. 4” Flexible aluminum duct (“Transition Duct”) **Page 12**
- h. 4” Worm Drive Clamp **Page 13**
- i. Booster Fan **Page 14**
- j. Wall Cap vent hood with damper 4” **Page 15**



## Dryer Vent Policy

February 24, 2021

Rev 2021-2

### Appendix A – Appurtenances - 10” radius smooth finish 90 degree 4” elbow

Dryer-Elb (LT-90)

<http://shop.dryerbox.com/s.nl/it.A/id.183/f>

#### Dryer-Elb (LT-90)

90 Degree Long Turn Dryer Elbow - The equivalent of straight pipe based on ASHRAE methodology for calculating friction loss, this is a great alternative to booster fans. The Dryer-Elb provides a net gain of approximately 4.5 feet in allowable duct length when used as a replacement to the standard 4" ell used in the dryer venting trade. 28 Gauge, ships in two pieces to be assembled in the field. **NOTE:** [Click here](#) (PDF), for Model 4D when used with the Long Turn Dryer-Elb Link to Engineering and Specs [Click Here](#). Contact James for Distributor Pricing or larger quantities.



4" Long Turn Dryer Elbow  
Measured Same as Straight  
Pipe

# Dryer Vent Policy

February 24, 2021

Rev 2021-2

## Appendix A – Appurtenances - Roof Cap vent hood with damper 4”

<b>AMERICAN</b> <b>aldes</b> VENTILATION CORPORATION	<b>Dryer Roof Cap</b>	PRODUCT SPECIFICATIONS and TECHNICAL DATA
		0910



### Dimensions

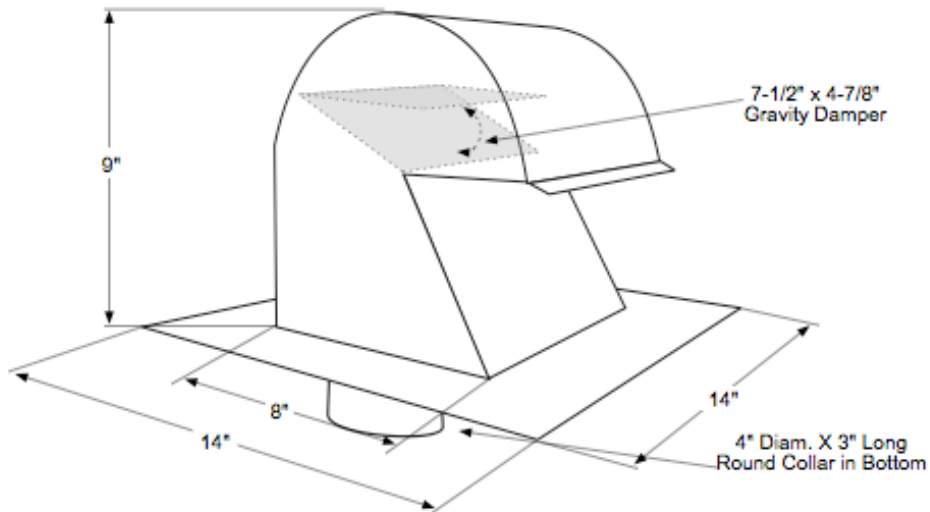

4521 19th Street Court E., Suite 104, Bradenton, FL 34203 USA  
Phone: 941-351-3441 | Fax: 941-351-3442  
www.americanaldes.com | E-mail: info@aldes-us.com



dryer\_roof\_cap\_spec\_0910

## Dryer Vent Policy

February 24, 2021

Rev 2021-2

### Appendix A – Appurtenances - Bird Screen

GH4W

[http://shop.dryerbox.com/s.nl/it\\_A/id.35/f](http://shop.dryerbox.com/s.nl/it_A/id.35/f)

#### GH4W

Deflecto Supurr-Guard Louvered Vent Hood with built-in Bird and Rodent Guard - 4" diameter. Most popular and most efficient wall hood for dryer venting exhaust termination with rodent protection, color is white. Does not include through-wall pipe. View specifications by [clicking here](#)



SUPURR-GUARD 4" louvered  
Vent by Deflecto w/rodent guard.  
[Good Airflow Efficiency Rating](#)

## Dryer Vent Policy

February 24, 2021

Rev 2021-2

### Appendix A – Appurtenances - 4" Flexible aluminum duct

ALUM-448

<http://shop.dryerbox.com/s.nl/it.A/id.206/f>

#### ALUM-448

Brand New, created specifically for our models 4D and 3D Dryerbox for downward exhaust direction but with very innovative custom ends. This is only available from our store and features an adaptive coupling on one end and a special expanded end on the other that better secures these sensitive connections. It measures 4" in diameter by 48" long (when stretched out) and 19" when compressed. This product has been custom cut to best fit our Down-box configurations. Any longer than 19" compressed may prevent the dryer from being located right against the wall. This aluminum flex product is almost always specified by the appliance manufacturer and offers the most efficient flexible transition hose. It is the most energy efficient to use.

**Please note:** This is too long to be used with our up-style boxes (425 and 350) but is a *no brainer* to purchase along with our 4D or 3D models. Use ALUM-439 for 425 and 350.

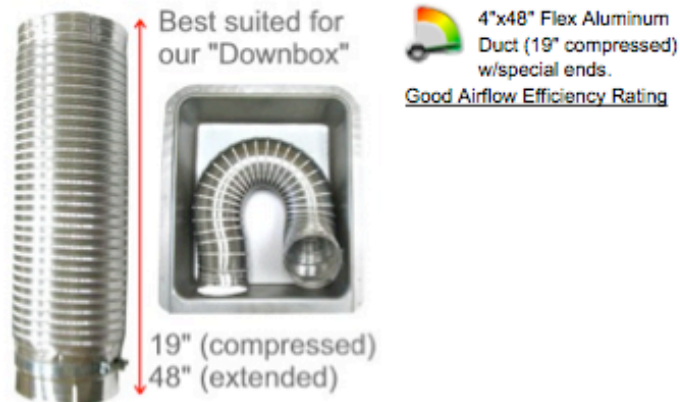

## Dryer Vent Policy

February 24, 2021

Rev 2021-2

### Appendix A – Appurtenances - 4" Worm Drive Clamp

MC4

<http://shop.dryerbox.com/s.nl/it.A/id.37/f>

#### MC4

The easiest and safest vent clamp available. Accommodates round and oval configurations. You'll need two of them in most cases.



Metal worm drive clamp for 4" dryer exhaust pipe

## Dryer Vent Policy

February 24, 2021

Rev 2021-2

### Appendix A – Appurtenances – Booster Fan



# Fantech DBF4XLT

## Dryer Booster Fan

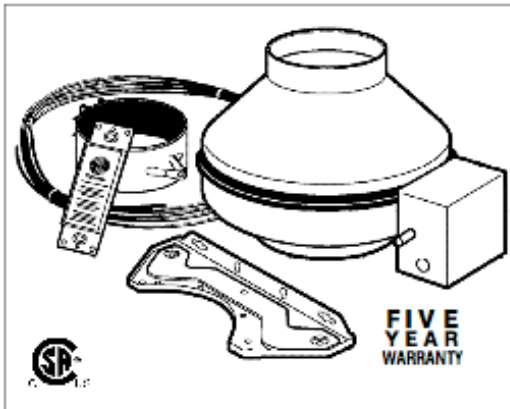

#### FEATURES

- Inline Dryer Booster Fan featuring self-cleaning backward curved impeller capable of maintaining an air velocity of 1200 fpm in duct systems up to 130 feet.
- Galvanized steel housing with powder-coat finish
- Integrated Pressure Sensing Switch
- Wall-mount indicator panel
- Uses 4" duct
- 5 1/2 foot 120Vac power cord
- Mounting bracket and hardware included

The Fantech DBF4XLT Dryer Booster Fan has been specially designed to solve the problems caused by long duct runs on clothes dryers.

According to dryer manufacturers and some local building codes, booster fans should be added in the dryer duct run when the length of the duct exceeds 24 feet with no bends, 20 feet with one bend or 15 feet with two bends.

#### HOW DOES IT WORK:

When the dryer is on, Fantech's patented pressure sensing switch automatically turns the booster fan on. The warm, moist air in the dryer duct is exhausted out of the building quickly.

The dryer booster fan monitors the status of the dryer and will turn itself off when the dryer stops.

Wall mounted indicator panel with LED display lets homeowners know that fan is fully operational.

#### SPECIFICATIONS

**FAN** – Inline fan with galvanized steel housing and baked powder-coat finish. Backward inclined blades of the motorized impeller allow lint to pass through the fan.

**PRESSURE SWITCH** Fantech's patented pressure switch automatically activates the booster fan when dryer comes on. Includes 18" of pressure sensing tubing with mounting grommet.

**INDICATOR PANEL** Wall-mount, low voltage indicator panel features an LED light that indicates to the homeowner that the fan is working properly. The indicator panel will alert homeowners of problems such as no power, blocked duct, locked motor rotor and low speed conditions. A 50 foot cable is included to connect the indicator panel to the booster fan.

Fan Model	RPM	Volts	Max Watts	Max Amps	Static Pressure in Inches W.G.									Max Ps	Duct Dia.
					0"	.125"	.25"	.375"	.5"	.75"	1.0"	1.25"	1.5"		
DBF4XLT	2800	115	83	0.73	195	181	167	153	141	120	101	81	55	2.05"	4"

Distributed by:

## Dryer Vent Policy

February 24, 2021

Rev 2021-2

### **Appendix A – Appurtenances – Wall Cap vent hood with damper 4”**

#### **Whirlpool 8212662 Flush Mount Louvered Flapper**

- or equivalent with similar horizontal louver pattern with four (4) louvers



# Dryer Vent Policy

February 24, 2021

Rev 2021-2

## Appendix B – Vent Plan Drawings

Boxed Soffit See VENT SPEC, latest Rev.	
Ceiling	15'
1 <sup>st</sup> Floor	4'
2 90 Deg. Elbow *	3' A
Cap (Damper)	1' B
Bird Screen	0' C
Equiv. Length	23'
Exclusive of Transition Duct	
* Dryer Elbow, 10" radius, smooth finish	



**DRYER – A1**

10/16/2010

Page 1 of 1

Important  
**Installer NOTICE – Unit Variations**  
on Page 4 of this Dryer Vent Policy.

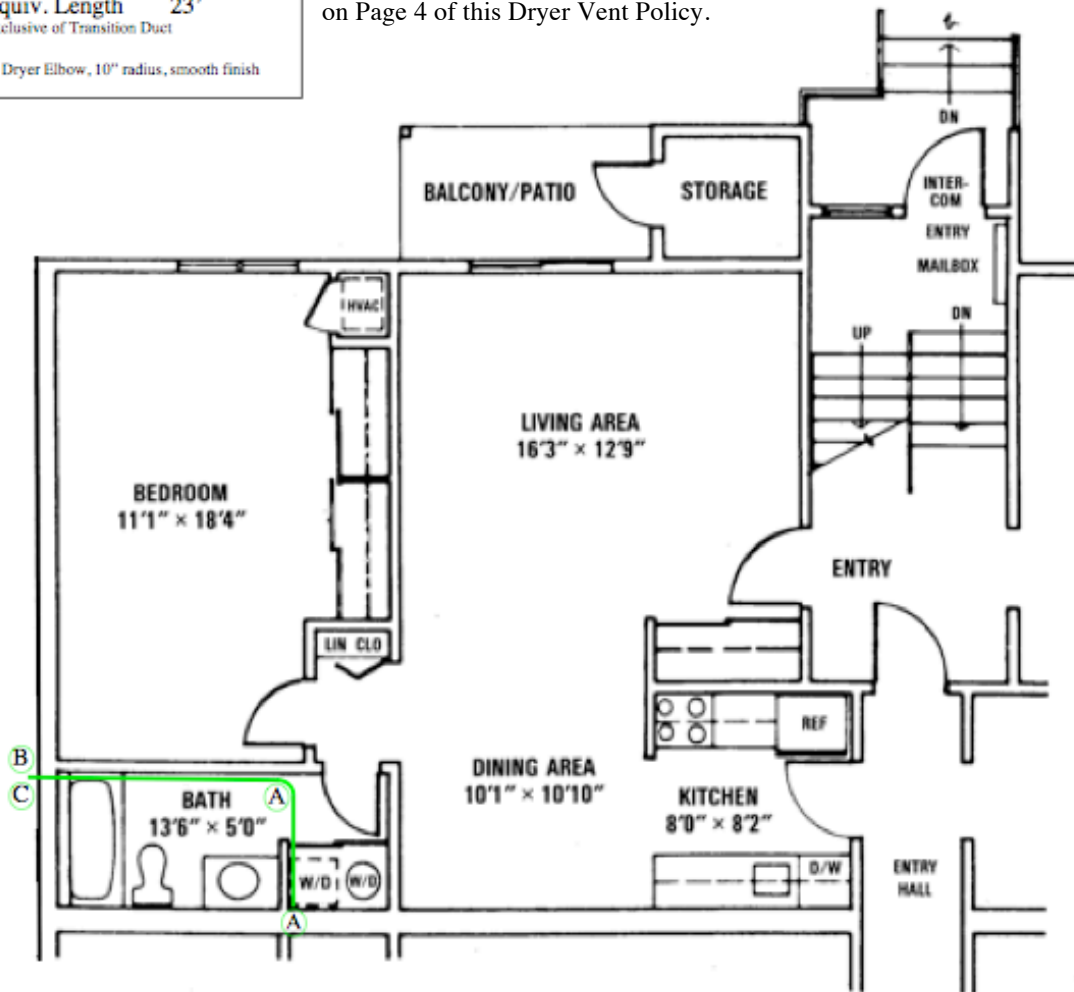

**Unit A1** Corner/End Units Not Top Floor  
**One Bedroom/One Bath**  
■ 778 Square Feet ■



Dryer Vent Policy

February 24, 2021

Rev 2021-2

Appendix B – Vent Plan Drawings (cont'd)

Common Area Ingress See VENT SPEC, latest Rev.	
Ceiling	8'
1 <sup>st</sup> Floor	4'
1 90 Deg. Elbow *	1.5' A
Cap (Damper)	1' B
Bird Screen	0' C
Equiv. Length	14.5'
Exclusive of Transition Duct	
* Dryer Elbow, 10" radius, smooth finish	



DRYER – A2

10/16/2010

Page 1 of 1

Important  
**Installer NOTICE – Unit Variations**  
on Page 4 of this Dryer Vent Policy.

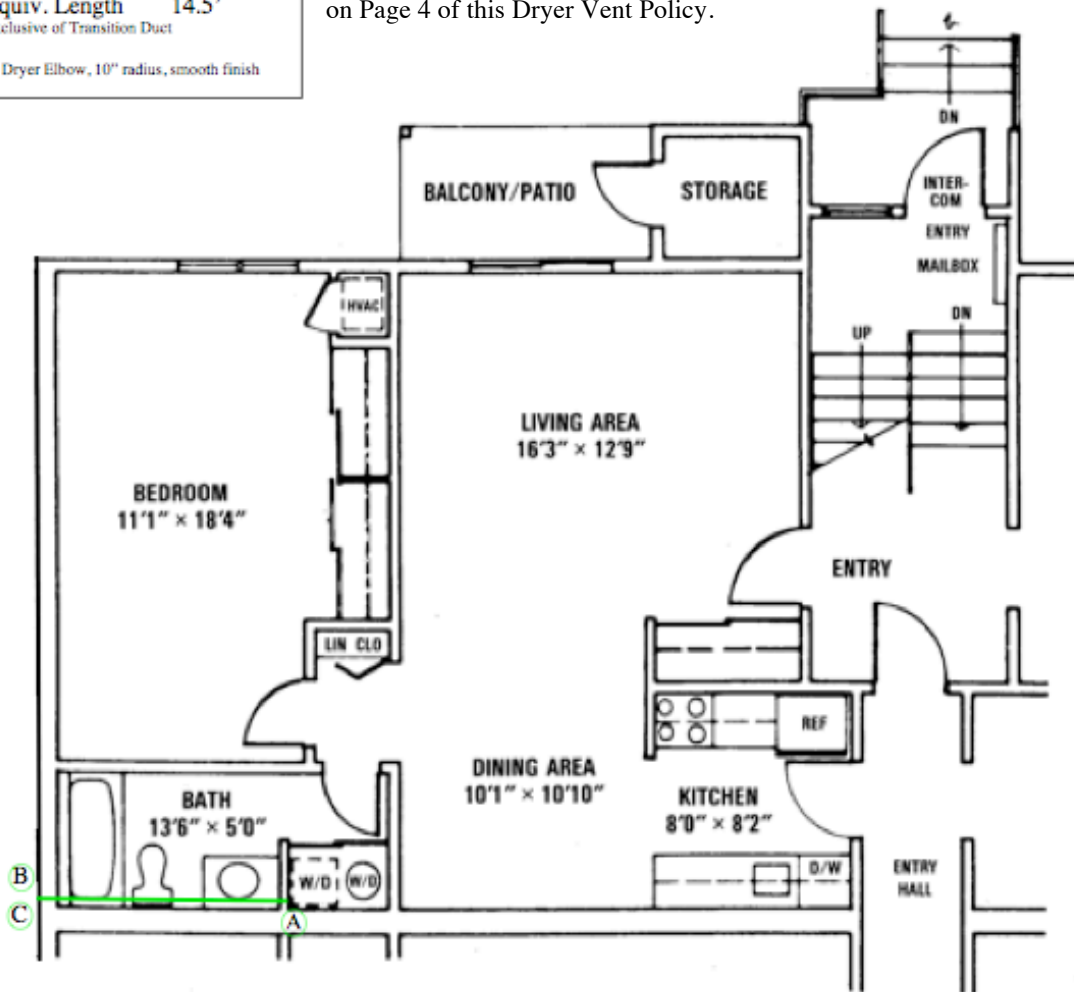

**Unit A2** Corner/End Units Top Floor  
**One Bedroom/One Bath**  
■ 778 Square Feet ■

Dryer Vent Policy

February 24, 2021

Rev 2021-2

Appendix B – Vent Plan Drawings (cont'd)

Boxed Soffit		
See VENT SPEC, latest Rev.		
Ceiling	26'	
1 <sup>st</sup> Floor	4'	
4 90 Deg. Elbow	20'	Z
Cap (Damper)	1'	B
Bird Screen	0'	C
Booster Fan	0'	D
Condensate Drain	0'	E
Fan Label	0'	F
Equiv. Length	51'	
Exclusive of Transition Duct		



DRYER – A3

10/16/2010

Page 1 of 1

Important  
**Installer NOTICE – Unit Variations**  
 on Page 4 of this Dryer Vent Policy.

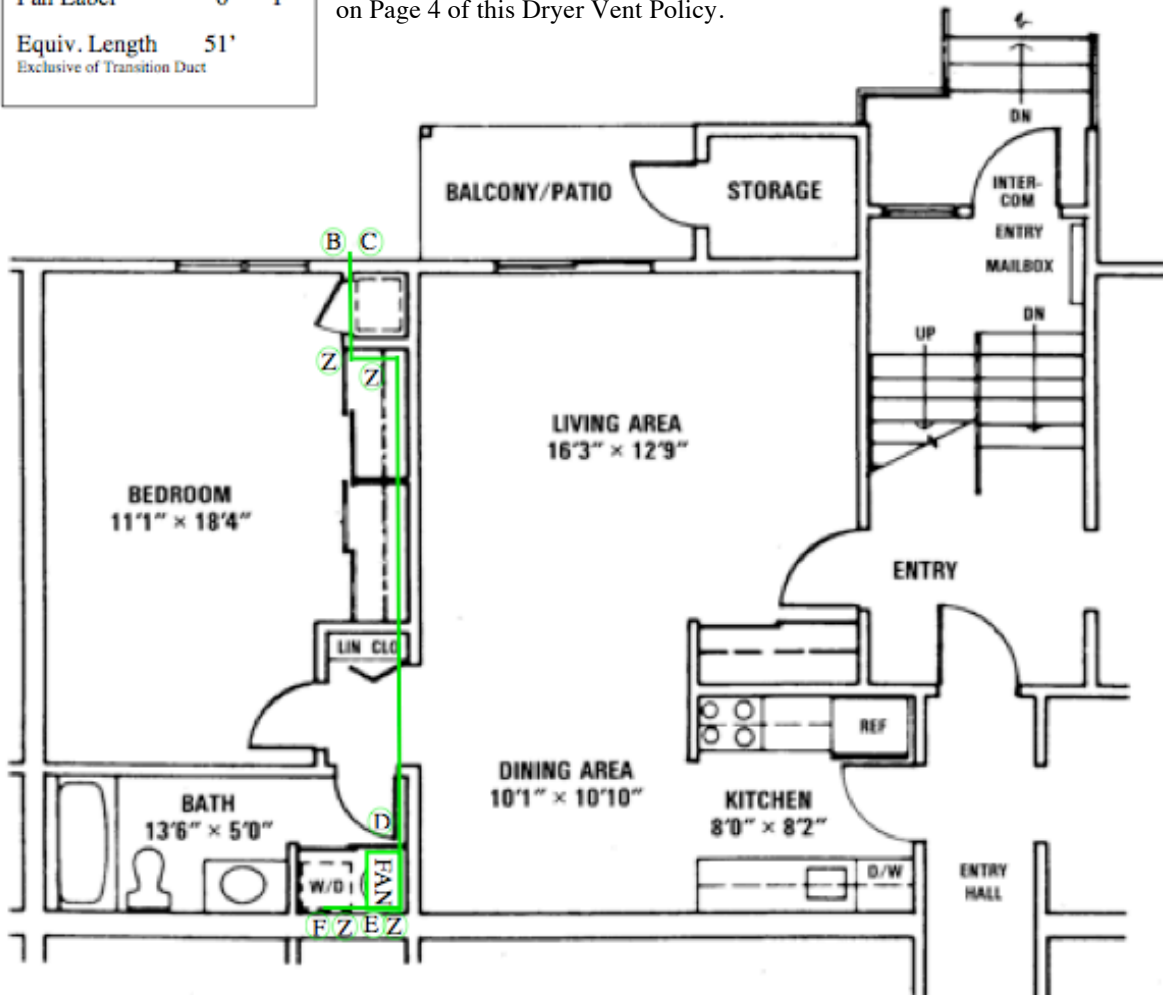

**Unit A3** Middle Units Not Top Floor  
**One Bedroom/One Bath**  
 ■ 778 Square Feet ■

# Dryer Vent Policy

February 24, 2021

Rev 2021-2

## Appendix B – Vent Plan Drawings (cont'd)

Common Area Ingress See VENT SPEC, latest Rev.	
Ceiling	18'
1 <sup>st</sup> Floor	4'
1 90 Deg. Elbow	1.5' *A
Cap (Damper)	1' B
Bird Screen	0' C
Equiv. Length 24.5'	
Exclusive of Transition Duct	
* 10" Radius, Smooth Surface Elbow	
B and C exit at Compressor Roof Knee Wall with Minimum 28" Roof Clearance	



### DRYER – A4

10/16/2010

Page 1 of 1

Important  
**Installer NOTICE – Unit Variations**  
on Page 4 of this Dryer Vent Policy.

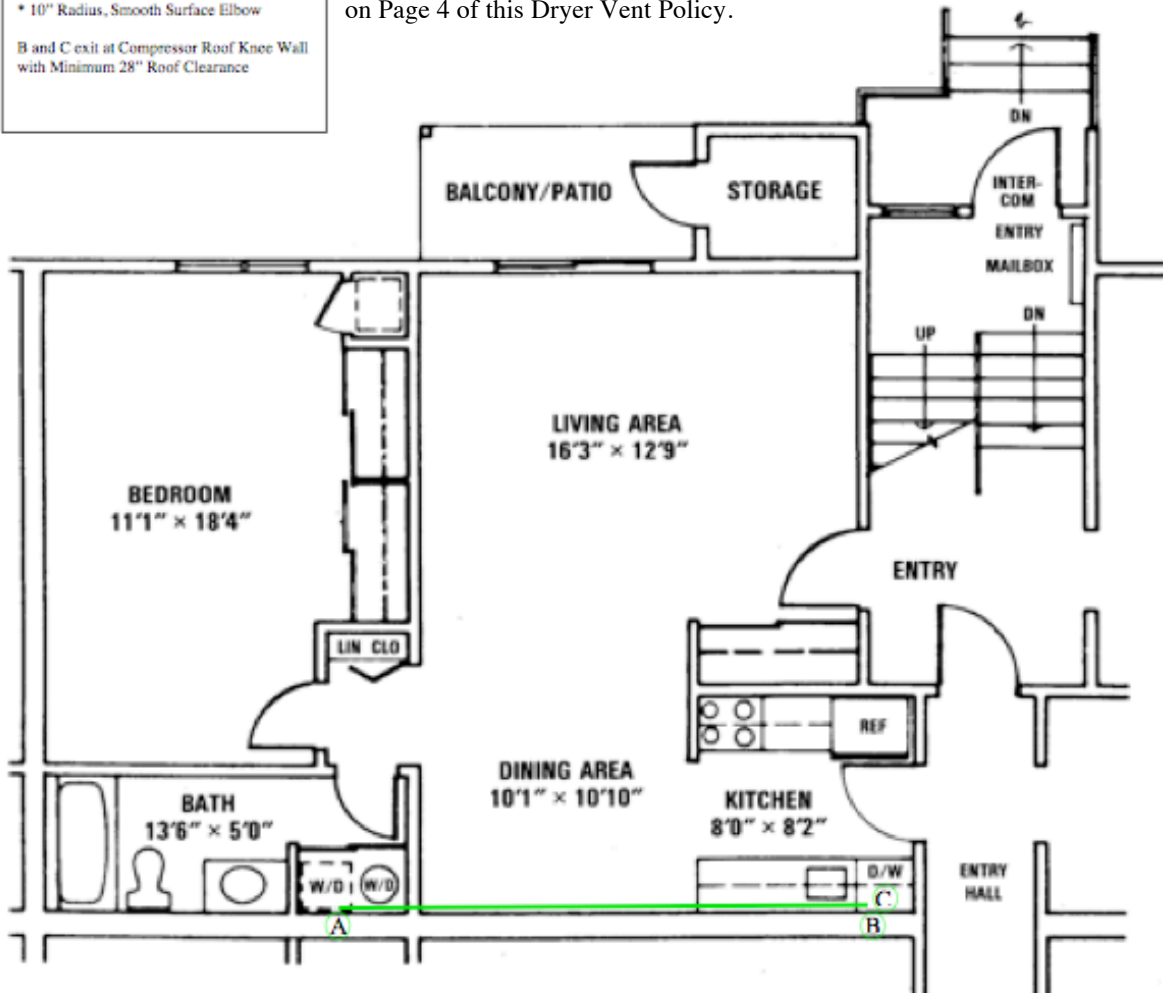

**Unit A4** Middle Units Top Floor  
**One Bedroom/One Bath**  
■ 778 Square Feet ■

# Dryer Vent Policy

February 24, 2021

Rev 2021-2

## Appendix B – Vent Plan Drawings (cont'd)

Boxed Soffit	
See VENT SPEC, latest Rev.	
Ceiling	20'
1 <sup>st</sup> Floor	4'
3 90 Deg. Elbow	15' Z
Cap (Damper)	1' B
Bird Screen	0' C
Booster Fan	0' D
Condensate Drain	0' E
Fan Label	0' F
Equiv. Length	40'
Exclusive of Transition Duct	

**Important**  
**Installer NOTICE – Unit Variations**  
 on Page 4 of this Dryer Vent Policy.

### DRYER – B1

11/14/2010

Page 1 of 1

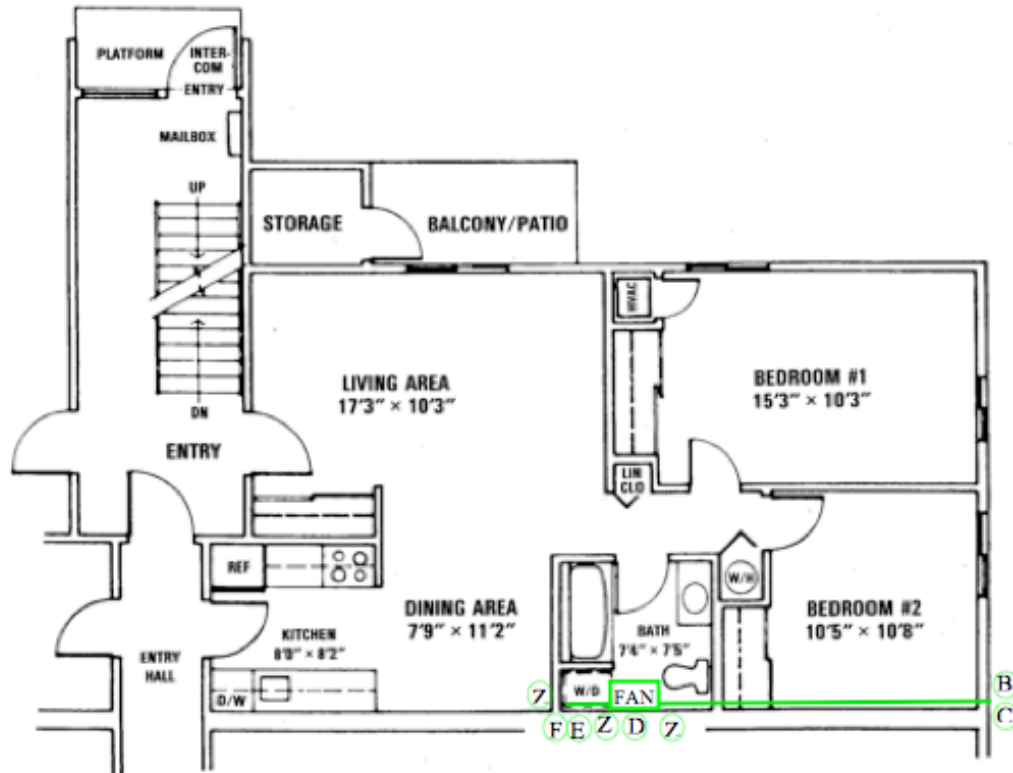

**Unit B1** End Unit Not Top Floor  
**2 Bedroom/1 Bath**  
 ■ **810 Square Feet** ■

# Dryer Vent Policy

February 24, 2021

Rev 2021-2

Common Area Ingress See VENT SPEC, latest Rev.	
Ceiling	16'
1 <sup>st</sup> Floor	4'
1 90 Deg. Elbow	1.5' *A
Cap (Damper)	1' B
Bird Screen	0' C
Equiv. Length 22.5'	
Exclusive of Transition Duct	
* 10" Radius, Smooth Surface Elbow	
B and C exit at Compressor Roof Knee Wall with Minimum 28" Roof Clearance	

Important  
**Installer NOTICE – Unit Variations**  
on Page 4 of this Dryer Vent Policy.

## DRYER – B2

11/14/2010

Page 1 of 1

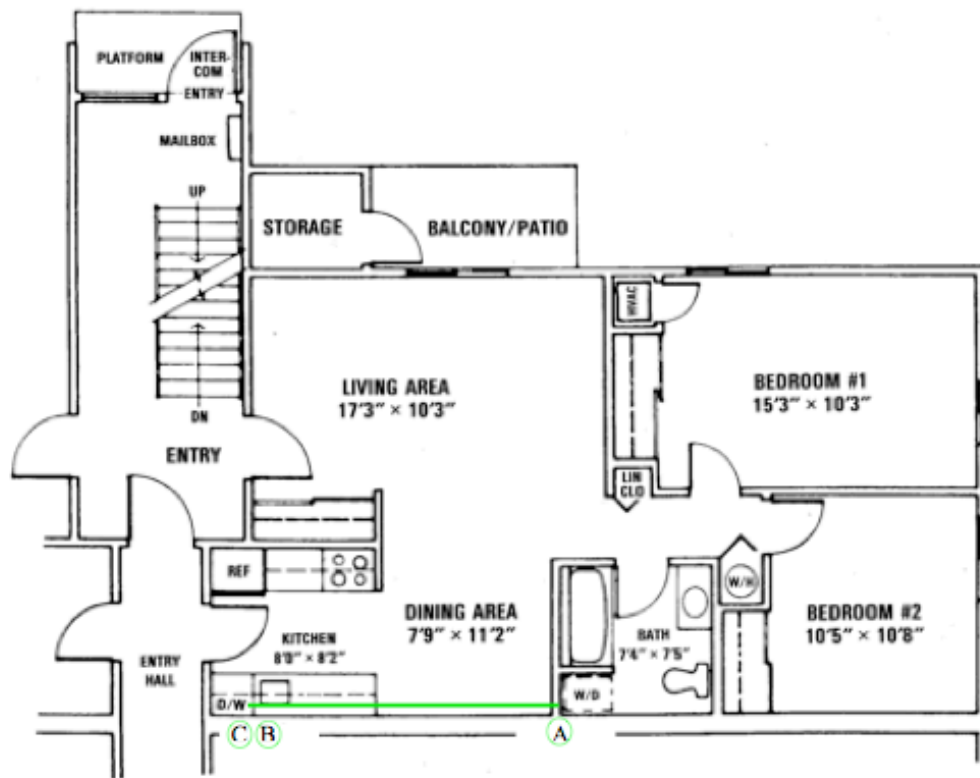

**Unit B2** End Unit Top Floor  
**2 Bedroom/1 Bath**  
■ **810 Square Feet** ■

# Dryer Vent Policy

February 24, 2021

Rev 2021-2

## Appendix B – Vent Plan Drawings (cont'd)

Boxed Soffit	
See VENT SPEC, latest Rev.	
Ceiling	25'
1 <sup>st</sup> Floor	4'
4 90 Deg. Elbow	20' Z
Cap (Damper)	1' B
Bird Screen	0' C
Booster Fan	0' D
Condensate Drain	0' E
Fan Label	0' F
Equiv. Length	50'
Exclusive of Transition Duct	



### DRYER – C1

11/14/2010

Page 1 of 1

Important  
**Installer NOTICE – Unit Variations**  
 on Page 4 of this Dryer Vent Policy.

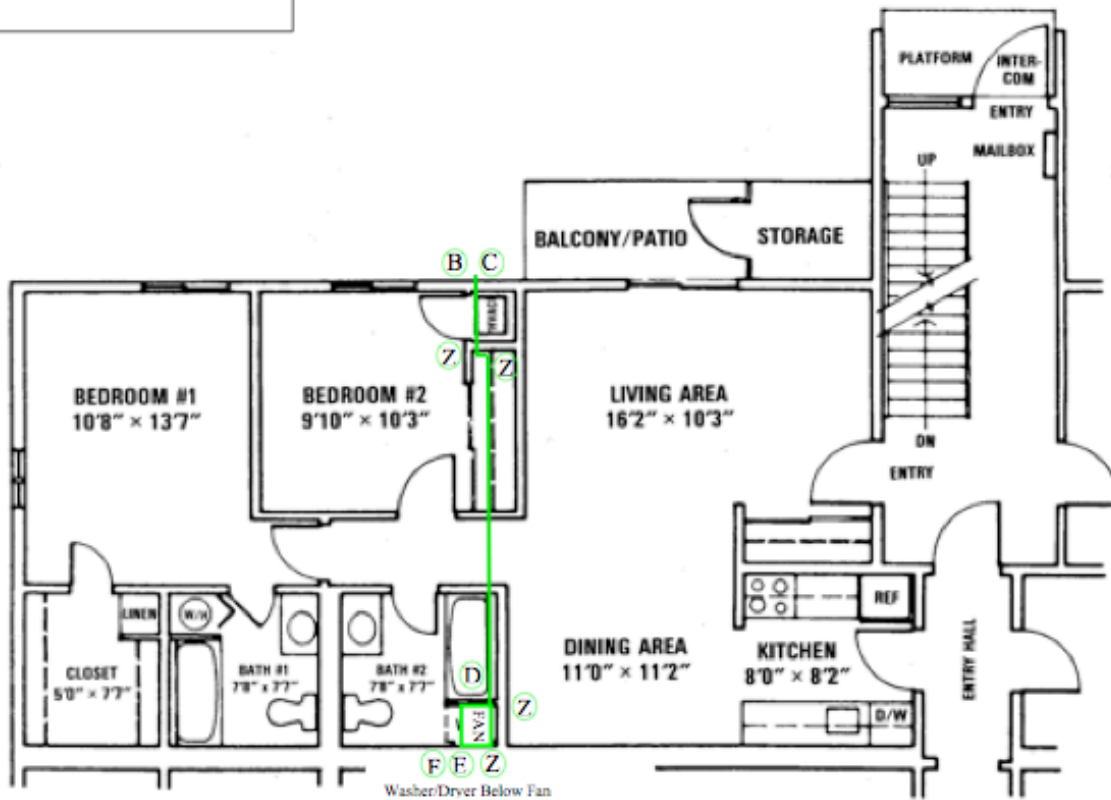

**Unit C1** Not Top Floor  
**2 Bedroom/2 Bath**  
 ■ **909 Square Feet** ■

# Dryer Vent Policy

February 24, 2021

Rev 2021-2

## Appendix B – Vent Plan Drawings (cont'd)

Common Area Ingress See VENT SPEC, latest Rev.	
Ceiling	17'
1 <sup>st</sup> Floor	4'
1 90 Deg. Elbow	1.5' *A
Cap (Damper)	1' B
Bird Screen	0' C
<b>Equiv. Length</b>	<b>23.5'</b>
Exclusive of Transition Duct	
* 10" Radius, Smooth Surface Elbow	
B and C exit at Compressor Roof Knee Wall with Minimum 28" Roof Clearance	



### DRYER – C2

11/14/2010

Page 1 of 1

Important  
**Installer NOTICE – Unit Variations**  
on Page 4 of this Dryer Vent Policy.

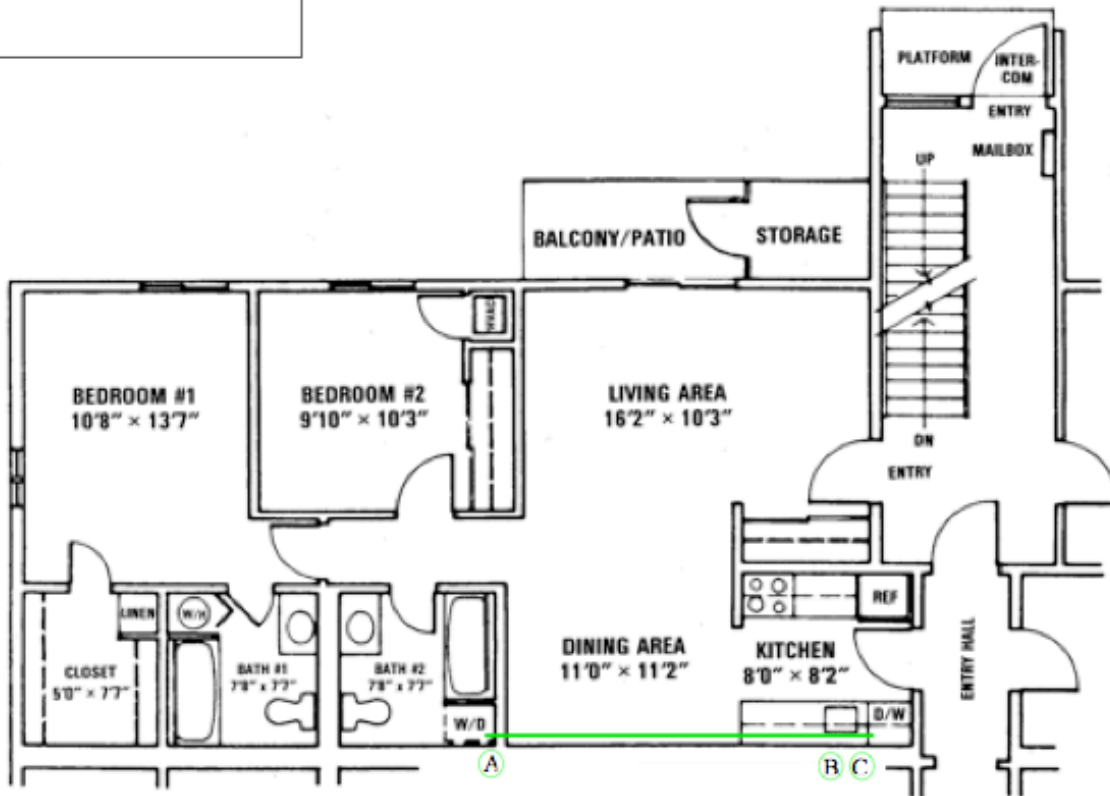

**Unit C2** Top Floor  
**2 Bedroom/2 Bath**  
■ **909 Square Feet** ■

# Dryer Vent Policy

February 24, 2021

Rev 2021-2

## Appendix B – Vent Plan Drawings (cont'd)

Common Area Ingress See VENT SPEC, latest Rev.	
Ceiling	16'
2 <sup>nd</sup> Floor	4'
1 90 Deg. Elbow	1.5' *A
Cap (Damper)	1' B
Bird Screen	0' C
Equiv. Length	22.5'
Exclusive of Transition Duct * 10" Radius, Smooth Surface Elbow	



### DRYER – D1

11/14/2010

Page 1 of 1

Important  
**Installer NOTICE – Unit Variations**  
on Page 4 of this Dryer Vent Policy.

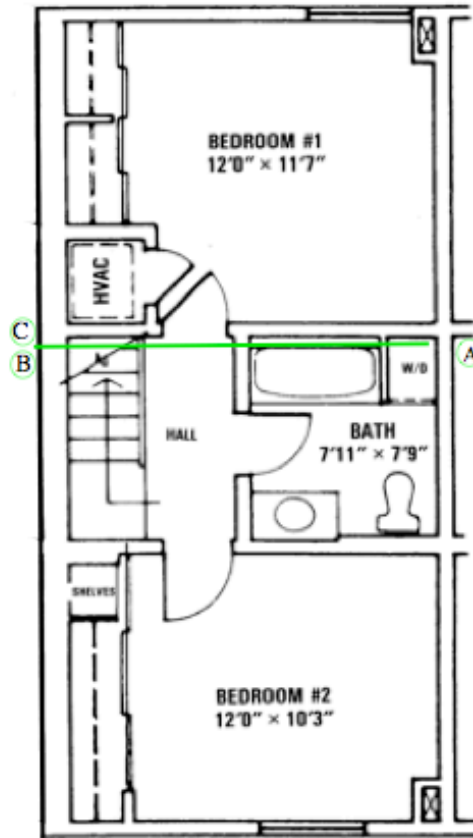

SECOND FLOOR PLAN

**Unit D1** End Units  
**2 Bedroom/1½ Bath**  
■ **961 Square Feet** ■



# Dryer Vent Policy

February 24, 2021

Rev 2021-2

## Appendix B – Vent Plan Drawings (cont'd)

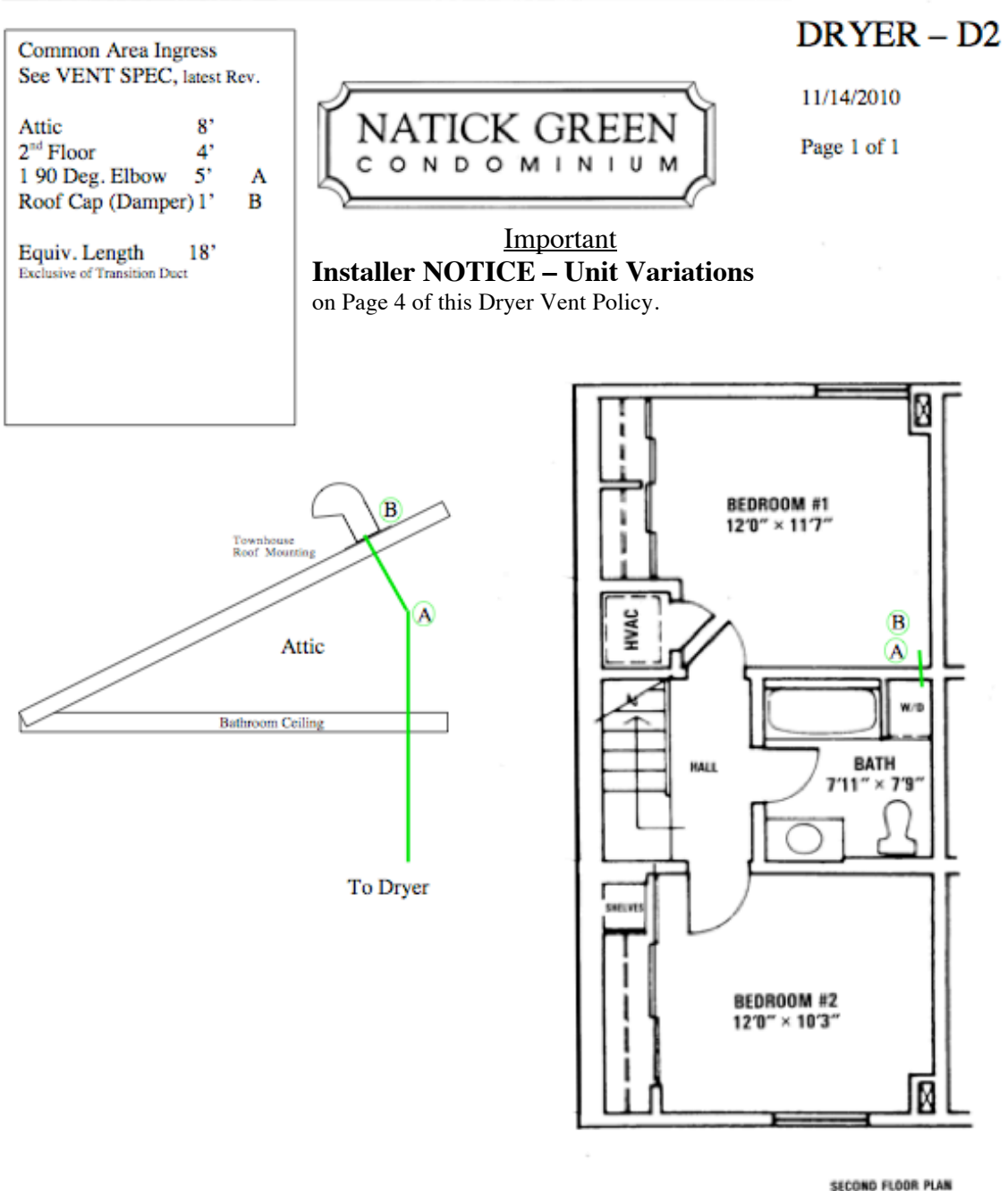

**Unit D2** Middle Units  
**2 Bedroom/1½ Bath**  
■ **961 Square Feet** ■