

A Review on Configurations based on Electric Spring for Power Factor Correction and Stability

RamanveerKour¹, Rajkamal²

¹*M.tech Scholar, EE, Jind Institute of Engineering and Technology, Haryana, India*

²*Assistant Professor, EE, Jind Institute of Engineering and Technology, Haryana, India*

Abstract- In this review paper we examine procedures for Electric Spring (ES) for Voltage and Power Stability and Power Factor Correction. The hypothesis on electric springs with capacitors for voltage adjustment is checked on to introduce a general thought on the conduct of ES, related to noncritical structure loads like electric warmers, coolers, and focal cooling framework. Further exchange centers around the rule of ES with batteries to cover its eight conceivable working modes and their value in giving line current guideline. The control scheme is theoretically contrasted and unique ES's control scheme where just receptive power is infused. The control scheme opens new roads for the usage of the ES to a more noteworthy degree by giving voltage and power strength and improving the power quality in the sustainable power source powered micro grids.

Keywords- Electric spring (ES), voltage stabilization (VS), Power Factor Correction, Power Stability, power quality, energy powered microgrid, current regulation

I. INTRODUCTION

Sustainable power sources (RESs) like sun oriented and wind are fundamental segments for a practical microgrid in future use. Be that as it may, their discontinuous and unusual nature represents an issue of power and voltage instability in the matrix. Different strategies have been examined in both at the source side and burden side to relieve this irregularity. Demand-side management (DSM) has been utilized effectively as a technique to constrict the impacts of sustainable power source discontinuity. Different strategies, for example, direct burden control, load booking, energy stockpiling, and so forth., are utilized to execute the DSM. Be that as it may, they can't be utilized progressively like burden planning or may be meddling to client like direct burden control. Which can give voltage and power stability progressively. The creators in used just receptive power remuneration to give voltage support progressively and load shedding for noncritical burdens. In an air conditioner framework, a solidarity power factor task is attractive to improve efficiency, diminish misfortunes, increment dynamic power conveyance, monetary favorable circumstances on network side gear, and so on. Power factor correction readdress (PFC) strategies like inactive capacitors and shunt condensers work impeccably in the customary matrix. Their

arrangements are controlled by the responsive burden and misfortunes in the circulation framework. With increment in nonlinear burdens and progression in power gadgets, gadgets, for example, DSTATCOM are being utilized to improve the power quality. In future microgrids with significant circulated sustainable power sources, it is wanted that we take a gander at PFC as a DSM issue. Structures will be quintessential components in such future microgrids. They can possibly actualize the idea of ES through different noncritical loads, for example, electric radiators, climate control systems, and fridges. The idea of ES can be stretched out further to improve the power factor in a sustainable power source powered microgrid. Since the ES is actualized through an inverter and by using its potential for both dynamic and receptive power remuneration this could be accomplished. The genuine power remuneration has been used to improve power balance in a three-stage framework and to improve the power factor with no voltage or power guideline. The spiral chordal decay (RCD) control and novel δ -control are a portion of the control systems to fuse PFC. Electrical parameters of the framework and network voltage (input voltage) are required to actualize the control scheme presented in and the control system won't be a demand-side arrangement. Control scheme in decouples framework voltage guideline and PFC of the ES-related brilliant burden. In this paper and in, we exhibit usage of the ES through an extemporized control scheme to give the power and voltage stability and generally PFC, an angle that has not been investigated yet in the writing. Likewise, a near investigation of this scheme versus the regular control scheme of ES is additionally done and displayed.

II. LITERATURE REVIEW

The ES was shown as a quick answer for the issue of voltage and power instability related with sustainable power source powered network. The genuine power remuneration has been used to improve power balance in a three-stage framework [and to improve the power factor with no voltage or power guideline. The outspread chordal disintegration (RCD) control and novel δ -control are a portion of the control methods to join PFC. Electrical parameters of the framework and lattice voltage (input voltage) are required to actualize the control scheme presented in and the control procedure won't be a demand-side arrangement [1].

Electric spring circuit configuration:

Fig.1: ES in a circuit

Electric Spring was acquainted by illustration parallels with a conventional mechanical spring. In a RES powered microgrid, it could be acknowledged through an inverter and is appended in arrangement with the noncritical burden, for example, electric radiators, coolers, and climate control systems, as appeared in Figure1, to shape a brilliant burden. In parallel to this keen burden, basic burdens like a structure's security framework are connected[1]. English physicist Robert Hooke depicted the idea of "Mechanical Spring" in the 1660's and following three centuries the idea of mechanical spring is executed in electrical routine called as "Electric Spring". Functional circuit and control execution of Electric spring for voltage guideline and responsive power pay of the AC mains. The voltage variances issue because of significant effect of discontinuous Renewable energy sources is unraveled by Electric Spring. Electric Spring is successful in settling the framework having discontinuous sustainable sources and empowering load demand to pursue power age. The difference in idea from Output voltage control (customary receptive power compensators) to Input voltage control (Electric Spring idea) of responsive power is likewise featured in the paper. Not at all like conventional receptive power remuneration strategy, this system handles responsive power as well as programmed power guideline in noncritical burdens. This is a worthwhile element which empowers non basic burden with installed electric spring to be versatile by future power network [2]. The electric spring is a developing innovation turned out to be compelling in i) settling brilliant network with considerable infiltration of discontinuous sustainable power sources and ii) empowering load demand to pursue power age. The unpretentious change from yield voltage control to include voltage control of a responsive power controller offers the electric spring new highlights appropriate for future keen network applications. The impacts of such unpretentious control change are featured, and the utilization of the electric springs in lessening energy stockpiling

prerequisites in power lattice is hypothetically demonstrated and essentially illustrated. Not at all like customary Statcom and Static Var Compensation advances, the electric spring offers responsive power remuneration as well as programmed power variety in non-basic burdens [3]. With expanding utilization of sustainable power source and the headways in savvy networks, demand side management has been a sharp point of intrigue. Structures, both business and residential, have extraordinary potential in executing load-side demand management in sustainable power source powered microgrids. Electric Spring, a shrewd matrix innovation, can give momentary voltage backing and burden power shedding. Along these lines, giving a clever answer for the voltage instability issue related with such microgrids. In electric spring is exhibited, related to building loads like focal cooling framework, to show its properties of voltage support, load power shedding, and responsive power remuneration [4]. The logical standard of "mechanical springs" was depicted by the British physicist Robert Hooke in the 1660's. From that point forward, there has not been any further improvement of the Hooke's law in the electric routine. This mechanical hole is filled by the improvement of "electric springs." The logical guideline, the working modes, the constraints, and the down to earth acknowledgment of the electric springs are accounted for. It is found that such novel idea has enormous potential in balancing out future power frameworks with considerable entrance of discontinuous sustainable power sources. The electric spring is observed to be viable in directing the mains voltage regardless of the vacillation brought about by the discontinuous idea of wind power. Electric machines with the electric springs installed can be transformed into first age of shrewd burdens, which have their power demand following the power age profile [5]. The electric springs (ESs) IS an answer for balancing out power matrix sustained by discontinuous sustainable power sources. With a battery or dynamic power source (DC, on the inside), the ESs can give both dynamic and responsive power remunerations. Up until now, three regular topologies of single-stage ESs have been accounted for. Not at all like conventional gadgets where power age pursues the heap demand, the ESs are related with non-basic burdens structure the alleged shrewd burdens that exchange the varied power to the non-basic burdens, adaptively, as per the discontinuous idea of power age [6]. A custom power gadget, is given in the wake of experiencing distributed writing in this field. An ES controls dynamic just as receptive power and subsequently can manage voltage alongside power quality improvement, within the sight of irregular and eccentric sustainable power sources. ES is associated in arrangement with part of the complete burden and can moist out the motions of the network by giving voltage guideline to the heap and goes about as a keen burden. Nearness of various ES can be envisioned in a dispersion feeder, acting all the while as one without having any

correspondence with in [7]. ES 'Electric Spring' which called as brilliant brace gadget which used to dispatch dynamic and responsive power in the framework which is associated between the Gird and Load or demand and supply. Legitimate choice of advancement strategies assumes a critical job in for the stability upgrade of power framework and improves the Power quality. Fuzzy improvement procedures contrasted and other traditional innovations and embraced. Damping controller is structured by utilizing fuzzy rationale controller. Vital ends have been drawn on the reasonableness of advancement system [8]. The standards of working the electric spring (ES) as a receptive power compensator and as a power factor corrector. The hypothesis on electric springs with capacitors for voltage adjustment is looked into to show a general thought on the conduct of ES. Further dialog centers around the rule of ES with batteries to cover its eight conceivable working modes and their convenience in giving line current guideline. An info current control scheme is intended for ES with batteries to approve its ability in power factor remedy. A low-voltage single-stage power framework with various sorts of burdens has been worked for confirming the plausibility of hypothesis of ES with batteries [9]

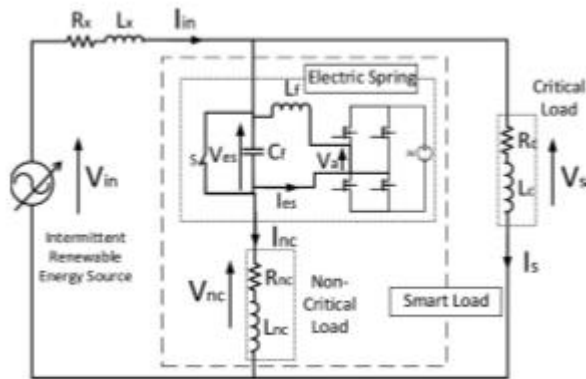
Use of ES in electrical system:

Electric spring is another technique to understand the voltage control of circulated energy, which can successfully understand the DSM without data trade. The best approach to settle the voltage on the supply feeder is moving the power vacillation to a wide-voltage load in arrangement with the electric spring, coordinating the energy on the demand and supply sides, the voltage on the supply feeder is balanced out. Writing presented the logical guideline, activity mode, confinement and functional utilization of electric spring, and filled the specialized hole in the field of electric spring. The electric spring to take care of the issue of voltage change brought about by wind power and effectively connected. The examination found that the electric spring can possibly address the stability issues presented by sustainable power source.

capacity over STATCOM, which demonstrates that the electric spring will be a promising innovation later on [9].

Power Quality intends to keep up simply sinusoidal current wave structure in stage with an absolutely sinusoidal voltage wave structure. Power quality improvement utilizing customary pay techniques incorporate numerous detriments like electromagnetic impedance, conceivable reverberation, fixed pay, cumbersomeness and so forth. In this way, power framework and power electronic architects need to create movable and dynamic arrangements utilizing custom power gadgets. This power molding hardware's utilization static power electronic converters to improve the power nature of dissemination framework clients. The gadgets incorporate Active Power Filter (APF), dynamic voltage restorer (DVR) and Unified Power Quality Conditioner (UPQC). APF is a compensator used to dispense with the aggravations in current. There are essentially two kinds of APFs: the shunt type and the arrangement type. This venture looks at the control of Shunt Active Power Filter (ES) in view of electric springs (mix of L and C) [10]. The idea of electric springs (ESs) has been an answer for balancing out power framework bolstered by discontinuous sustainable power sources. With a battery or dynamic power source (DC, on the inside), the ESs can give both dynamic and responsive power pay. Up until now, three run of the mill topologies of single-stage ESs have been accounted for. Not at all like conventional gadgets where power age pursues the heap demand, the ESs are related with non-basic burdens structure the supposed savvy stacks that exchange the vacillated power to the non-basic burdens, adaptively, as indicated by the irregular idea of power age. In the wake of assessing the primary control systems of single-stage ESs, the breaks down their points of interest and hindrances just as their appropriate applications. Examinations among various control techniques on a particular topology form are executed. At long last, ends and conceivable future patterns are called attention to [11].

practical power circuit implementation of Electric SpringCircuit:

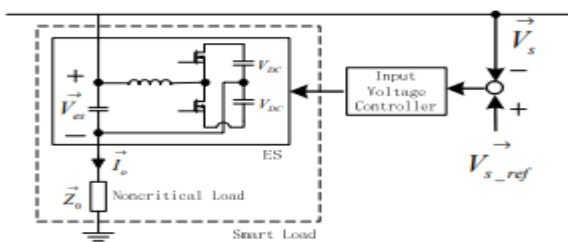

Fig.2: Use of ES in electrical system.

The utilization of electric spring in sustainable power source framework can diminish the lattice's demand for energy stockpiling. Writing contrasted the electric spring and STATCOM, the examination found that utilizing the electric spring at a similar limit has preferable voltage guideline

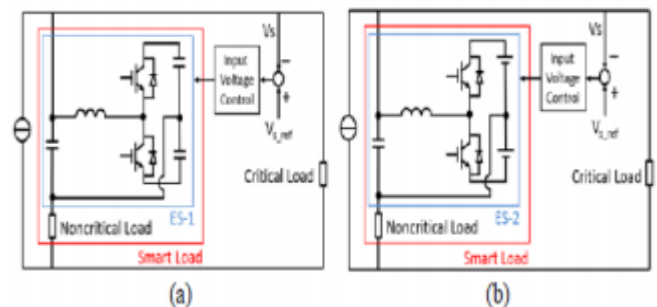

Fig.2: The practical power circuit implementation of ES. (a) ES version-1. (b) ES version-2.

ES has been basically acknowledged with power electronic circuits for improving both voltage and recurrence stability in small scale matrix equipment test system. Similar capacities for voltage and recurrence stability have likewise been effectively assessed in a reproduction ponder for a medium measured power framework involving a few power generators.

III. CONCLUSION

The standards and activities of the electric springs (ES) with DC-interface capacitors and with batteries are researched and successfully reviewed. The first proposition of the ES with capacitors gives receptive power pay to mains voltage adjustment and programmed non-basic burden power variety for adjusting power supply and burden demand. By supplanting the DC-interface capacitors with batteries (or associating the battery over the dc connect capacitor of the inverter), the ES can work in eight working modes, which empower the ES to give power factor remedy.

IV. REFERENCES

- [1]. Jayantika Soni et al., "Electric Spring for Voltage and Power Stability and Power Factor Correction" IEEE Transactions on Industry Applications, Vol. 53, No. 4, July/August 2017
- [2]. Pallavi G Bendre et al., "Development and Control of Electric Spring to Improve the Stability of Future Smart Grid with Intermittent Renewable Energy Sources" (IJERT) ISSN: 2278-0181 IJERTV4IS030696 www.ijert.org Vol. 4 Issue 03, March-2015
- [3]. S Priyadarshini et al., "Reduction of Energy Storage Requirements in Future Smart Grid Using Electric Springs" An ISO 3297: 2007 Certified Organization Vol. 3, Special Issue 1, February 2014
- [4]. Jayantika Soni et al., "Load-side Demand Management in Buildings using Controlled Electric Springs" <https://escholarship.org/uc/item/0p12n8nm>, 2014-11-06
- [5]. Shu Yuen et al., "Electric Springs—A New Smart Grid Technology" IEEE Transactions on Smart Grid, Vol. 3, No. 3, September 2012
- [6]. Qingsong Wang et al., "The State of the Art of the Control Strategies for Single-Phase Electric Springs" Appl. Sci. 2018, 8, 2019; doi:10.3390/app8112019
- [7]. Mehul Dansinh Solanki et al., "Recapitulation of Electric Spring: A Smart Grid Device for Real Time Demand Side Management and Mitigating Power Quality Issues" 978-1-4799-5141-3/14/\$31.00 c 2016 IEEE
- [8]. P. Nitish Raj et al., "Modeling of Electrical spring for improving Power stability and Power Factor" Volume 7, Issue IX, September/2018
- [9]. Yan Shuo et al., "Electric Spring for Power Quality Improvement" 978-1-4799-2325-0/14/\$31.00 ©2014 IEEE
- [10]. J.C. Nivetha et al., "Electric Springs for Reducing Power Imbalance and Hystereis In Three Phase Power Systems" ISSN: 0976-1353 Volume 20 Issue 3 – MARCH 2016.
- [11]. Qingsong Wang et al., "The State of the Art of the Control Strategies for Single-Phase Electric Springs" Appl. Sci. 2018, 8, 2019; doi:10.3390/app8112019