

Solidworks/2014

3D Modelling Tutorial

L3

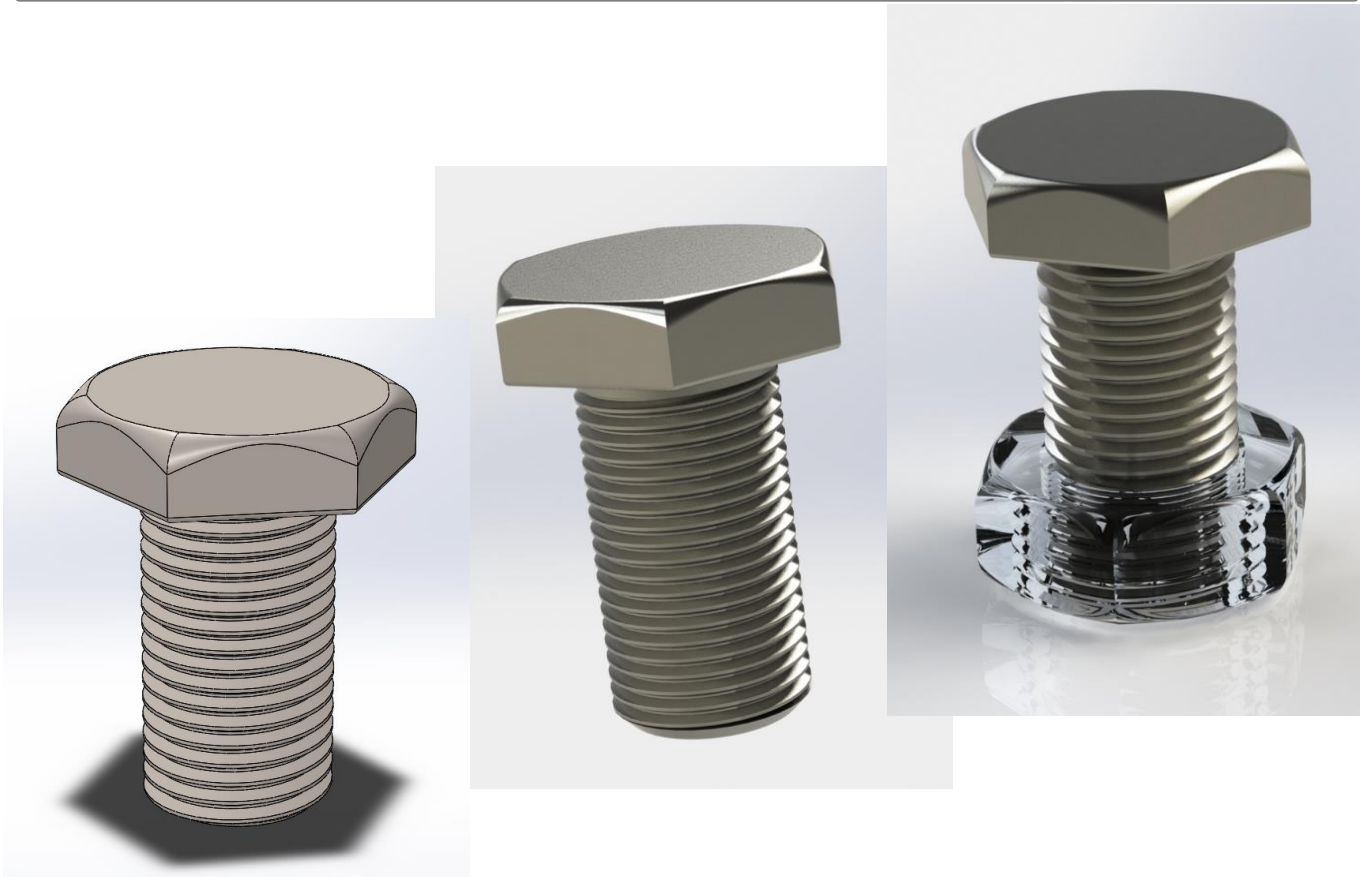

Mr Billington 2014 ©

Learning Outcome; M12 Machine Bolt

Skill Level; 3 Advanced

3D; *Helix, Swept Cut, Extrude, Fillet, Variable Fillet, Chamfer*

2D; *Polygon, Modify dimension, Line, Helix*



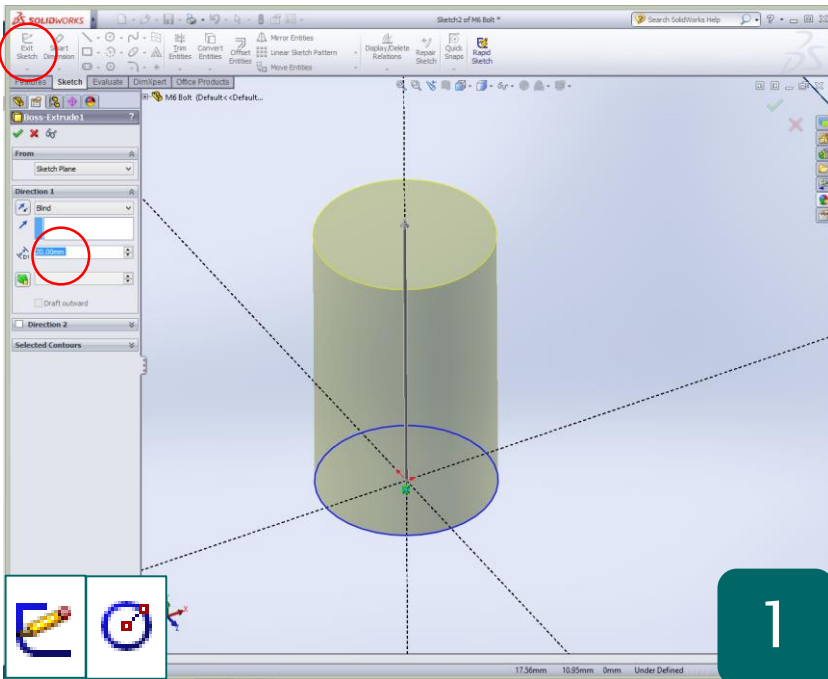

- Start a new Part file and sketch a 12mm diameter circle using the circle tool in 'Sketch'
- Access the 'features toolbar'
- Extrude by 20mm using 'Extruded Boss'
- Confirm with the green tick

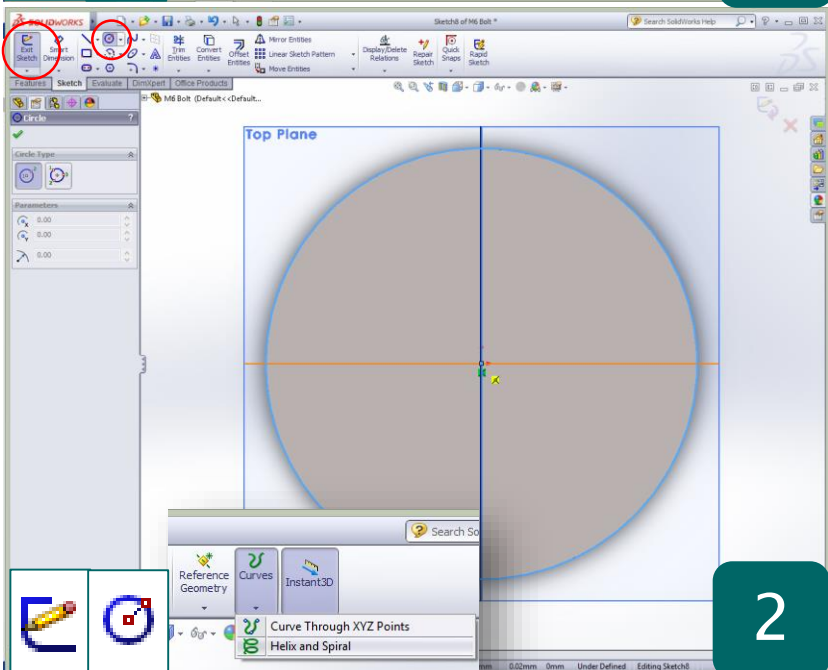

- Access the 'features toolbar' and select 'Curves' then 'helix/spiral'
- Select the top of the cylinder to sketch the circle
- Using the 'circle tool' draw a circle which snaps onto the outside of the cylinder to match the diameter
- **Exit sketch**

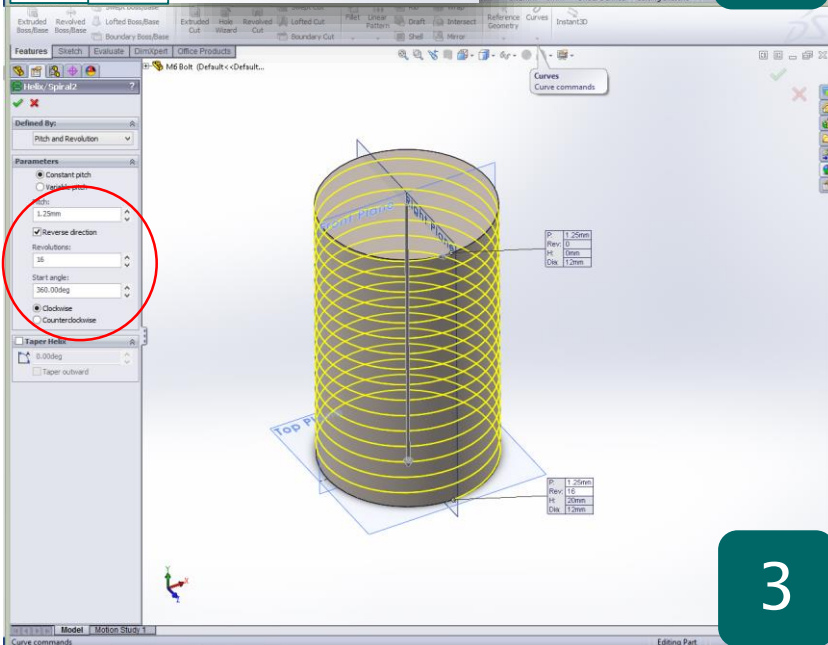

- In the left 'feature menu' set the parameters as follows;
- **1.25mm** pitch depth (pitch of M6 bolt)
- **16** Revolutions
- **360°** Start angle
- Clockwise spiral
- Confirm with the green tick

Why? – The pitch of a M12 thread is 1.25mm. This can be adjusted for varying bolt sizes along with the revolutions. If the helix travels the wrong way down the cylinder 'reverse direction'

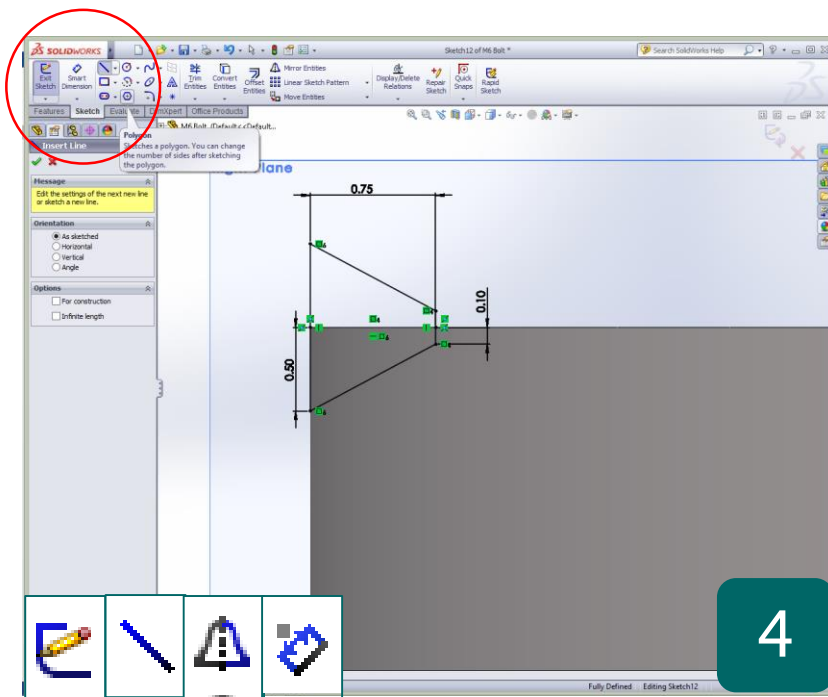

- Select the vertical work plane that the end of the 'helix' meets
- Click 'Sketch' and use **CTRL + 8** to bring the workspace view 'normal to'
- Create the sketch shown using the 'line tool' and the 'smart dimension tool'
- Ensure the sketch snaps to the edge of the cylinder
- Use the 'Mirror' tool to improve accuracy and save time

Why? – This tooth shaped profile will form the thread for the M12 bolt. Depending on the size of bolt this can be altered however it is meant as a rough estimate in terms of dimensions.



4

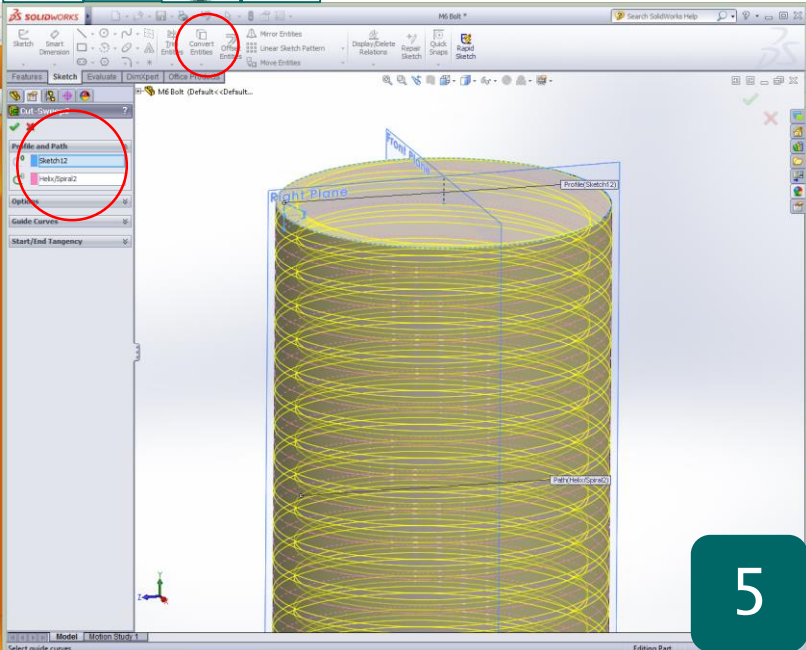

- Access the 'features toolbar' and select 'Swept Cut'
- Select the **profile** as the 'sketch' completed above and in the 'path' box select the helix
- If the preview matches the one shown then confirm the feature with the green tick

Why? – A swept cut can be used for many different design elements such as a lip on a casing or a slot cut out. As with a 'Swept Boss' it requires a profile and a path

5

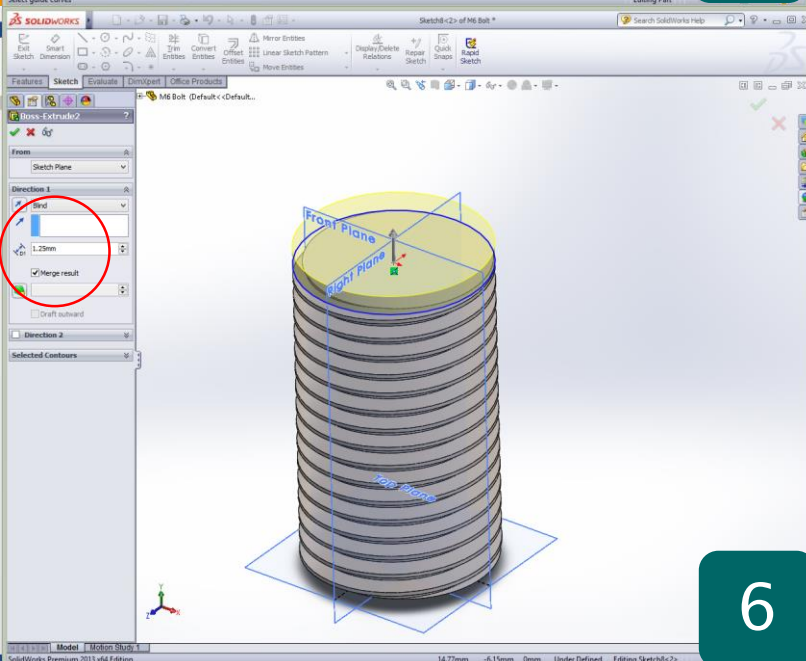

- Select the top face of the cylinder and click 'Sketch'
- Sketch a circle to with a **6mm** radius to match the top of the cylinder
- Extruded boss by **1.25mm**
- Confirm with the green tick

Why? – A bolt tends to have a relief before the head of the bolt which allows the thread to be machined in the machining process. This is simulated with a short extrude

6

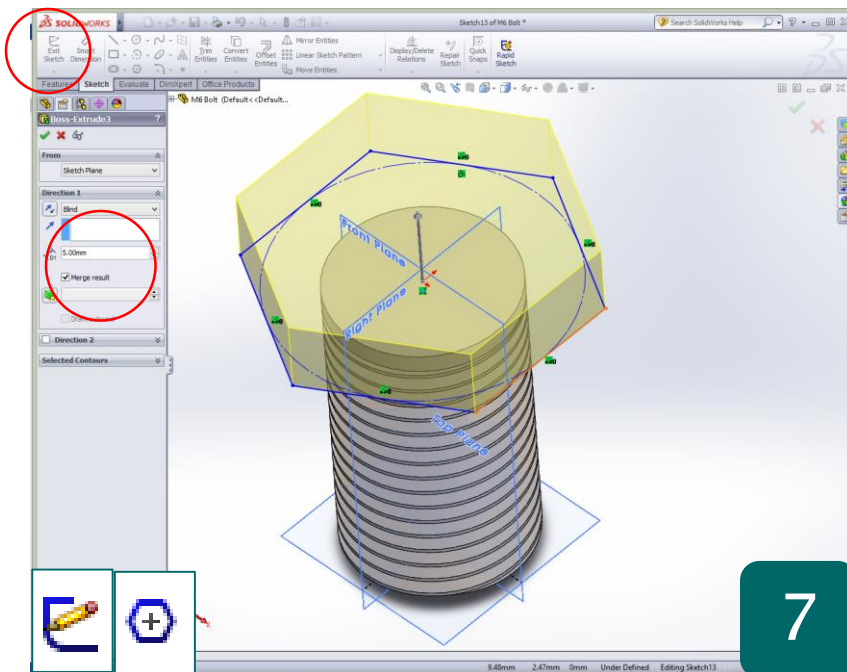

- Select the top newly extruded face
- Click 'Sketch' in the sketch toolbar and use the **CTRL + 8** shortcut again
- 'Polygon tool' sketch a hexagon from the centre of the circle
- Use 'smart dimension' to set the distance between the two parallel sides to **18mm**
- Access the 'features toolbar' and extrude the hexagon by **5mm**
- Confirm with the green tick

Why? - The top of a bolt can have a range of different finishes and shapes depending on the application. Feel free to adjust this step to suit.

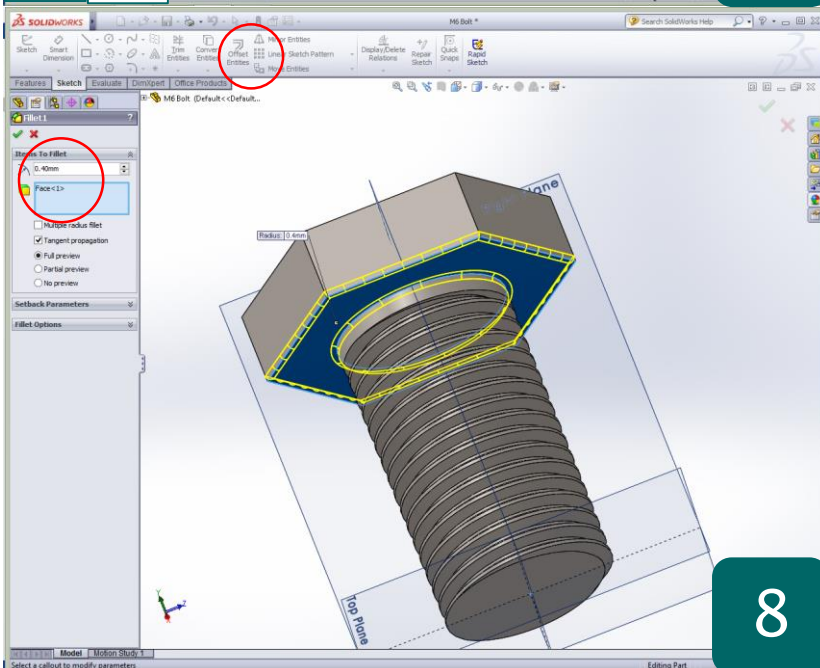

- Access the 'features toolbar'
- 'Fillet' 0.4mm to the bottom edge and join on the bolt
- This can be increased or decreased depending on preference
- Confirm with the green tick

Why? – This further enhances the realism by adding the rounded edges created in the manufacturing process of the bolt. Equally it will enhance the final render

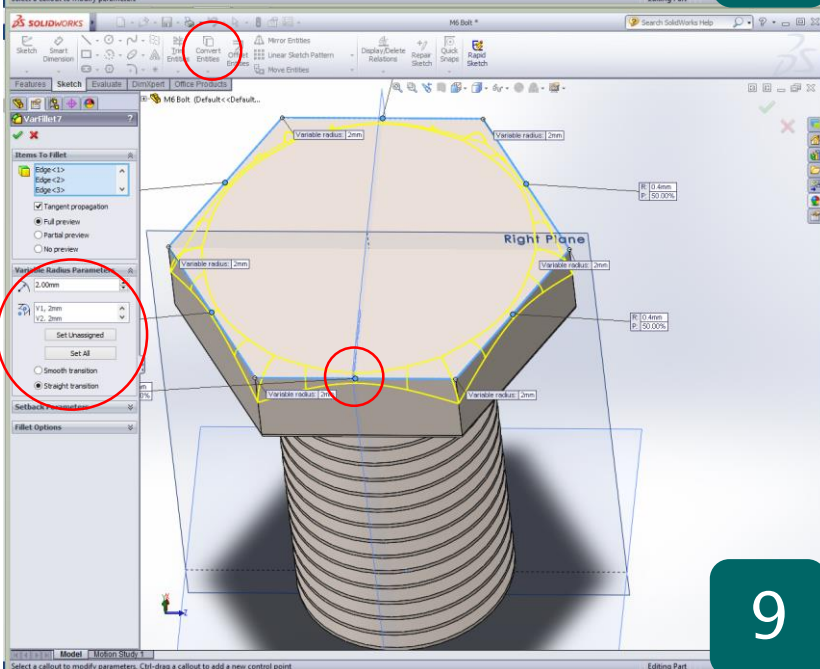

- Access the features menu
- Select 'Fillet' and click 'Variable Radius' in the left 'feature menu'
- Set the 'number of instances' to '1' from the original 3
- Click on 'Straight Transition'
- Select the first edge of the hexagon
- Select the middle dot that appears
- Type **0.4mm** into the radius box and press ENTER
- Repeat this for each edge setting the middle point to 0.4mm each time
- When done hold SHIFT and select all of the 'V's form the selection list
- Type a **2mm** radius and hit ENTER
- If preview matches confirm with tick

Why? – A variable radius can great complex geometry by varying the radius along a set edge

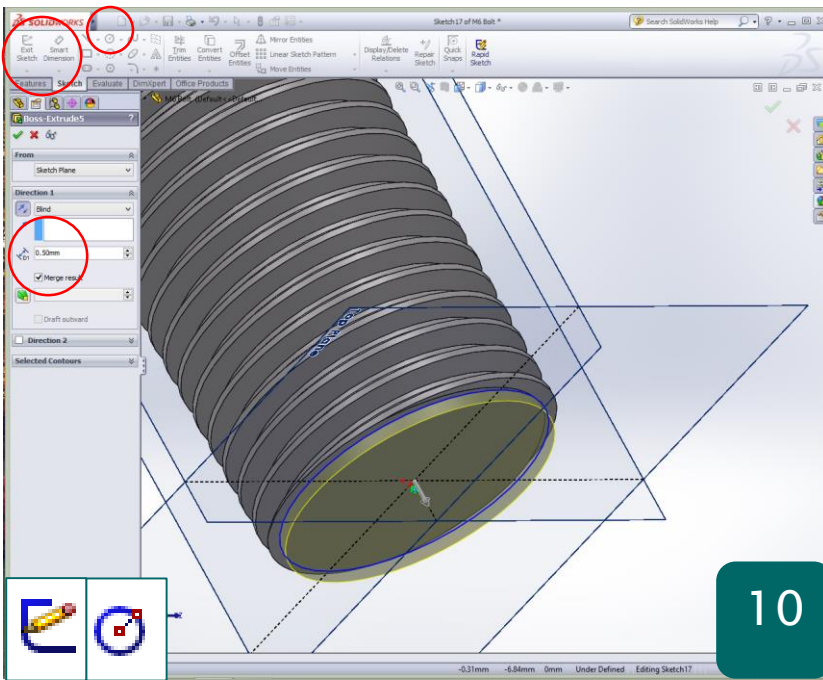

10

- Access the sketch menu and select the base of the thread
- Click 'sketch'
- Bring the view 'normal to' using CTRL + 8
- Copy the base circle using the circle tool
- Extrude the circle by 0.5mm
- Confirm with the green tick

Why? – This extrusion is a rough estimate and can be changed depending on design. It will form the chamfered end of the bolt that allows it to be lined up with the corresponding thread

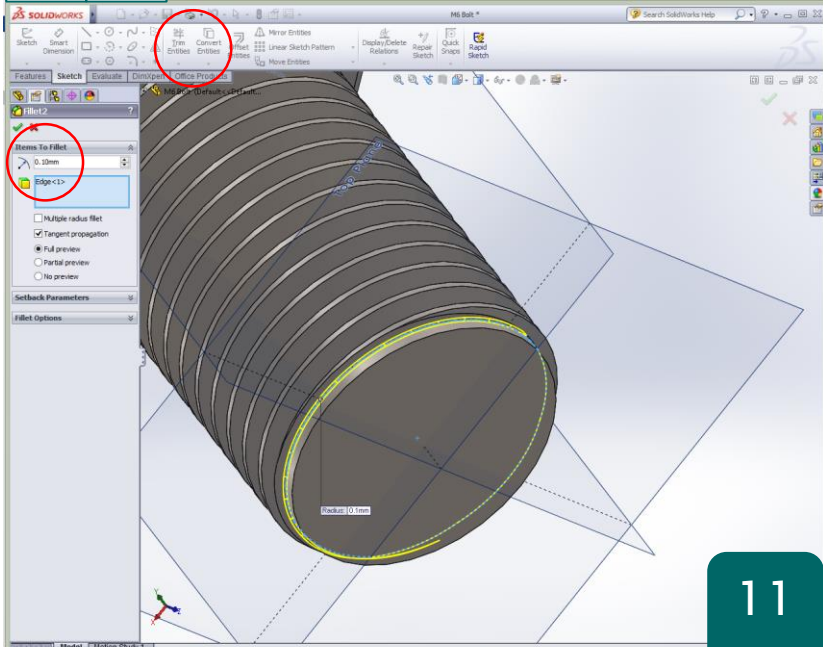

11

- Fillet the joining edge of the extrusion by 0.2mm
- This will not follow around the whole circumference of the side due to the thread creating a 3D helix
- Confirm with the green tick

Why? – It is rare that a perfectly formed 90° corner is made on any model and good practice to apply a slight fillet to enhance the models realism

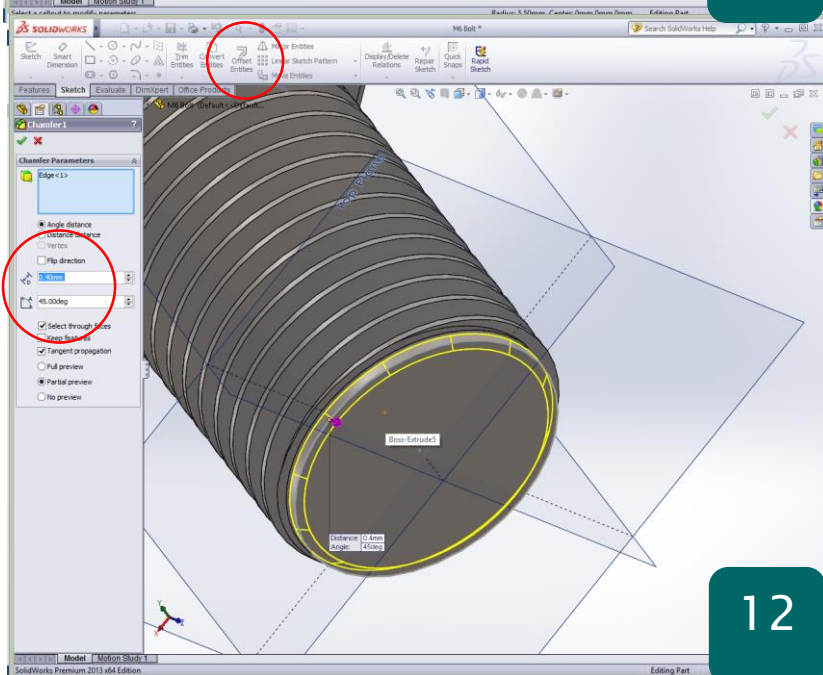

12

- Complete the model with a final 'Chamfer' feature
- Select the base edge and set the 'distance' to 0.4mm
- This will remove the sharp edge from the end of the bolt and replicate the finish seen in real world bolts
- If you have time you can try to develop a corresponding M12 nut using the same techniques
- They can then be assembled together to test using the 'Screw thread' mate option

Why? – Although a bolt is not something which would be CAD modelled as they are uniform and standardized it introduces new skills in Solidworks