

Version #0218



INSTALLATION & OPERATING USER MANUAL

**FOUR CYLINDER
LEVELING SYSTEMS:**

*Automatic Leveling
Platinum Leveling
Wireless Leveling
Manual Leveling*

**TWO CYLINDER
SYSTEMS:**

Stabilizing Systems

**VEHICLE
APPLICATIONS:**

*RVs / Motorhomes
Specialty Vehicles*

**QUADRA MANUFACTURING
BIGFOOT LEVELING SYSTEMS**

305 US 131 SOUTH
WHITE PIGEON, MI 49099
800-752-9815 (PHONE)
269-483-9636 (FAX)



BIGFOOTLEVELER.com

 Like us on
facebook.com/thebigfootleveler



First, identify your leveling system. Then follow with mounting cylinders and tank assemblies. Next, install hydraulic hose, wiring harnesses and electrical controls. Finally, connect the system to battery. Once completed, test and bleed the hydraulic lines.



Previous Version



Automatic System

Automatically levels the vehicle with supreme precision.
 Manual operation feature.
 All-up & Ignition safety feature.
 Emergency Retract operation.
 Lifetime warranty on cylinders.
 Central & Quad Pump Formats.

Operation page 2
 Cylinders pages 5-13
 Tank Assembly pages 14-18
 Wiring pages 19-21, 28-29
 Bleeding page 22
 Troubleshooting page 23
 Warranty page 30

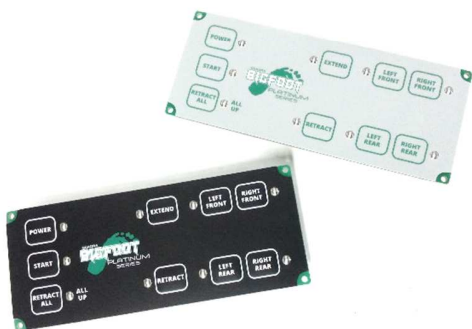

Platinum System

Automatically deploys all four jacks to level the vehicle from front to rear.
 Manual operation feature.
 All-up & Ignition safety feature.
 Simple, no nonsense design.
 Central Pump System.

Operation page 3
 Cylinders pages 5-13
 Tank Assembly page 14,18
 Wiring pages 19-21, 28-29
 Bleeding page 22
 Troubleshooting page 23
 Warranty page 30



Wireless System

Freedom to roam while operating.
 Operates two jacks simultaneously to prevent frame twist/damage.
 All-up safety feature.
 Central Pump System.

Operation page 4
 Cylinders pages 5-13
 Tank Assembly page 14,18
 Wiring pages 19-21, 28-29
 Bleeding page 22
 Troubleshooting page 23
 Warranty page 30



Manual System

Operates jacks individually or all at once.
 All-up safety feature.
 Emergency Retract operation.
 Quad Pump System.

Operation page 3
 Cylinders page 5-13
 Tank Assembly page 15, 18
 Wiring pages 19-21, 28-29
 Bleeding page 22
 Troubleshooting page 23
 Warranty page 30



2pt Stabilizing Systems

Wireless, Rocker & Dual Controls

Cylinder/Tank pages 5-13,15,18
 Controls/Wiring page 24-27
 Power/Plumbing page 21,22
 Warranty page 30

Automatic Leveling System Controls

Control Panel Operation...

- Make sure the key is out of the vehicle ignition.
- Previous version of panel to the right.



1. Turn panel/system on and let system run through its diagnostic mode. Lights will flash clockwise around the green foot. (System will not operate with the ignition key ON)
2. When the lights stop flashing, it's time to choose your function (MANUAL or AUTOMATIC). If choosing MANUAL, press and hold button until light comes on. For AUTOMATIC, simply press once and release.
3. When in the MANUAL mode, each leveler may be operated individually. FRONT operates right front. RIGHT operates right rear. REAR operates left rear. LEFT operates left front. When using this feature it is important to level the coach by using two levelers at a time or together. For example, right front and right rear, this puts less stress on the frame. To retract individually, press and hold the RETRACT button & the jack button. To retract all, press & hold MANUAL until light goes off, then press RETRACT.
4. When using the AUTOMATIC feature, simply press the AUTO button and then let the system operate itself. It is important at this time that there is NO MOVEMENT IN THE COACH. This process will take 1-3 minutes. To retract the levelers simply turn panel on and press RETRACT.

Programming / Reprogramming the Automatic Leveling System

Turn panel/system on and let system run through its diagnostic mode. Lights will flash clockwise around the green foot.

When the lights stop flashing, push the button labeled "FRONT" 5 times. Then press the button labeled "REAR" 5 times. Once you have done this all lights on panel will begin to flash. This means you have reached in the system what is called zero mode. At this time you can operate each corner or pair of levelers individually.

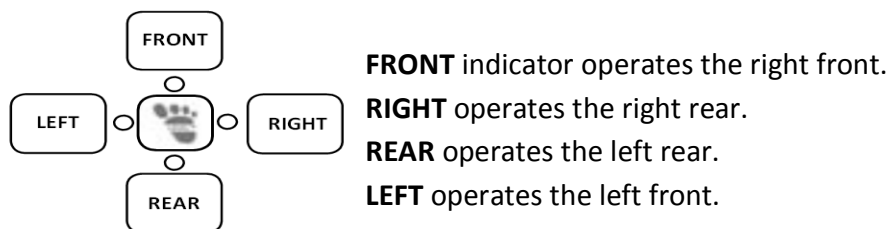

Keep in mind the twisting/flexing of the vehicle's frame.

Try to operate jacks in pairs when possible.

Once you have the coach level, you can now store a new program into the leveling sensor (brain box). To do so, press the **RETRACT** button **3 times**. The AIR DUMP light will then be the only light flashing. It will flash for 20 seconds then shut off and the green, Level Foot will start flashing. The leveling sensor is now (re)programmed. If you do not want to store the new program, simply turn off panel, to avoid changing the original program.

Platinum Leveling System Controls

Control Panel Operation...

Panel also available in black, NOTE: 1. Panel turns on when ignition turns on to inform user if jacks are up or down (alarm sounds). 2. Due to another safety feature, to operate the "START" and "RETRACT ALL" buttons, press and hold the button for 1-2 seconds then release.

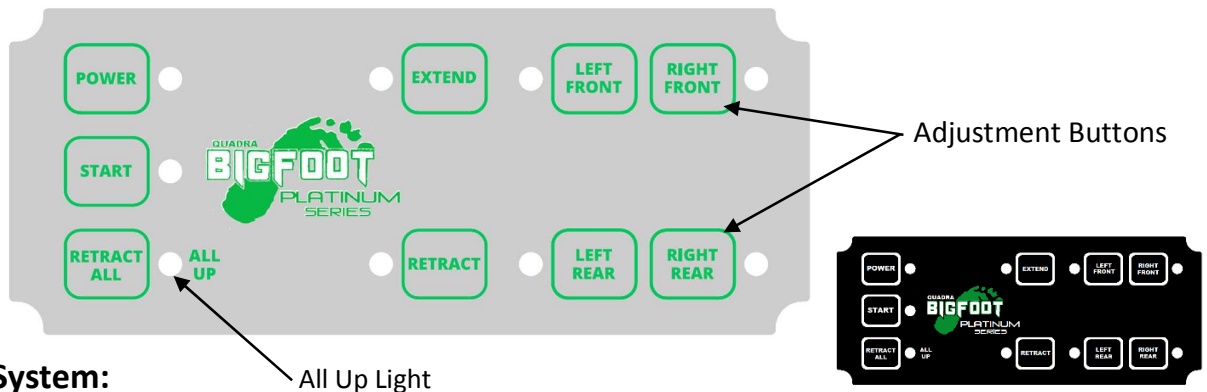

Extend System:

1. Press the **Power** Button (Red LED will come on constant).
2. Press the **Start** Button, this brings the front of the vehicle nearly level to the rear and stabilizes the rear as well. (LED will come on until program is finished, pressing any button during operation will cancel program, Vehicle Ignition must be OFF).
3. Done! Vehicle is now stabilized, *if* additional adjustments are desired:
 1. Press **Extend** (now in "Extend Mode" LED will come on).
 2. Press & Hold the Adjustment Button for the designated corner(s) of the vehicle that is low or high. (Ex. Right or Curb side is low, press & hold RIGHT FRONT & RIGHT REAR until level, driver's side is considered the left side for reference).
4. **Power Off** (panel will automatically shut off after 10 minutes of no activity).

Retract System:

1. Press the **Power** Button (Red LED will come on).
2. Press the **Retract All** Button until the green "**All Up**" light comes on constant. (This process will take up to 60 seconds. After 60 seconds the green light will flash, this means that one or more of the jacks did not fully retract, see troubleshooting)

Always do a visual check to verify that all the jacks are fully retracted prior to operating the vehicle.

Manual Leveling System Controls

Turn panel on, press Extend or Retract, then press & hold the designated jack or press & hold the All button to operate all four jacks simultaneously. This panel has the All up feature as well and an air dump feature if equipped. Press and hold Emergency Retract to retract jacks in-case of limit switch failure.

Wireless Leveling System Controls

- STEP 1:** Press the “WAKE” button on the remote to turn receiver on.
- STEP 2:** To lift the Front of the coach, press “FRONT” then “EXTEND.” Hold this down until the coach moves, then release.
- STEP 3:** To lift the Rear of the coach, press “REAR” then “EXTEND.” Again hold this down until the coach moves, then release.
- STEP 4:** To lift the Driver side of the coach, press “DRIVER” then “EXTEND.” Hold until desired height is reached, then release.
- STEP 5:** To lift the Passenger side of the coach, press “PASSENGER” then “EXTEND.” Again, hold until desired height is reached, release.
- STEP 6:** Press “WAKE” to put the system to sleep.



- STEP 1:** When you are ready to leave press “WAKE” to turn on the receiver.
- STEP 2:** To lower the Rear of the coach, press “REAR” then “RETRACT.” Hold this down until the rear jacks are completely retracted.
- STEP 3:** To lower the Front of the coach, press “FRONT” then “RETRACT.” Again hold this down until the front jacks are completely retracted.
- STEP 4:** Press “WAKE” to put the system to sleep.

The indicator light & alarm will alert you when one of the jacks are down before you drive away. This is a standard feature on the wireless system.



Installing the Wireless Receiver

Plug the receiver pigtail into the plug attached to the central pump tank assembly. Mount the receiver using the provided TEK screws in an easy to access area without placing it in harm's way. For example, although the receiver is weatherproof, face the front component side of the receiver towards the rear of the vehicle where road debris reduce the risk of damaging the receiver.

If you are having trouble with your wireless setup (intermittent performance) the wireless connection may have some interference based on the location of the receiver (Ex. thick steel boxes) you may need to relocate your wireless receiver to another area, such as inside the coach. In order to do this you will have to order a part from Quadra Manufacturing (800-752-9815) “EZ Extension Harness - Part#: M41600”



Cylinder Installation & Assembly

Mounting the Cylinders

Pre-assemble jack prior to hanging on previously mounted weld-on bracket.

- Attach foot pad with $\frac{3}{4}$ " thin jam nut using a 1 $\frac{1}{16}$ " socket.
- Remove port plugs with $\frac{3}{16}$ " allen wrench.
- Install supplied JIC elbow fittings to the bottom & top ports with a $\frac{9}{16}$ " wrench.
- **DO NOT** install the extend hose to the top port on central pump systems yet, this will be done later on in installation (due to the length of hose they must go through a bleeding process).
- Place $\frac{1}{4}$ " clevis pin in limit switch barrel then insert threaded limit switch with $\frac{7}{8}$ " wrench.
- For jack locations see diagrams on the following pages, but typically the front jacks should be under the cab and the rear jacks should be within 60" behind the rear axle.
- If it is a weld-on application, make sure the weld-on bracket is level and you get good penetration to the frame with full welds the entire length of the bracket. Sometimes it is easier to mount jack prior to welding by lifting assembly with floor jack, be sure to verify levelness and ground clearance.
- Hang jack using at minimum of four $\frac{7}{16}$ " x 1.75" grade 8 bolts, hex nuts & lock washers. If you have 17k-lb or larger jacks (3 $\frac{3}{8}$ " diameter or larger) you need a minimum of six bolts per jack. Prior to tightening, verify jack is straight & level using carpenter's level. Tighten with $\frac{5}{8}$ " wrench on bolt, $\frac{11}{16}$ " socket on nut, tighten to 70 ft.-lbs. (See Fig. 1)

Fig. 1

The jack pictured in this diagram may not match the jack for your vehicle specific or universal kit.

Identifying jacks by diameter:

- 2 $\frac{3}{8}$ " = 8k-lb jack
- 2 $\frac{7}{8}$ " = 12k-lb jack
- 3 $\frac{3}{8}$ " = 17k-lb jack
- 3 $\frac{7}{8}$ " = 24k-lb jack

See bottom of page 9 & 11 for possible vehicle modifications, torque specs & typical jack locations and additional instructions...

If mounting the rear jacks between the vehicle's frame rails also called an "inside mount" a crossbrace is required in the installation for structural stability.

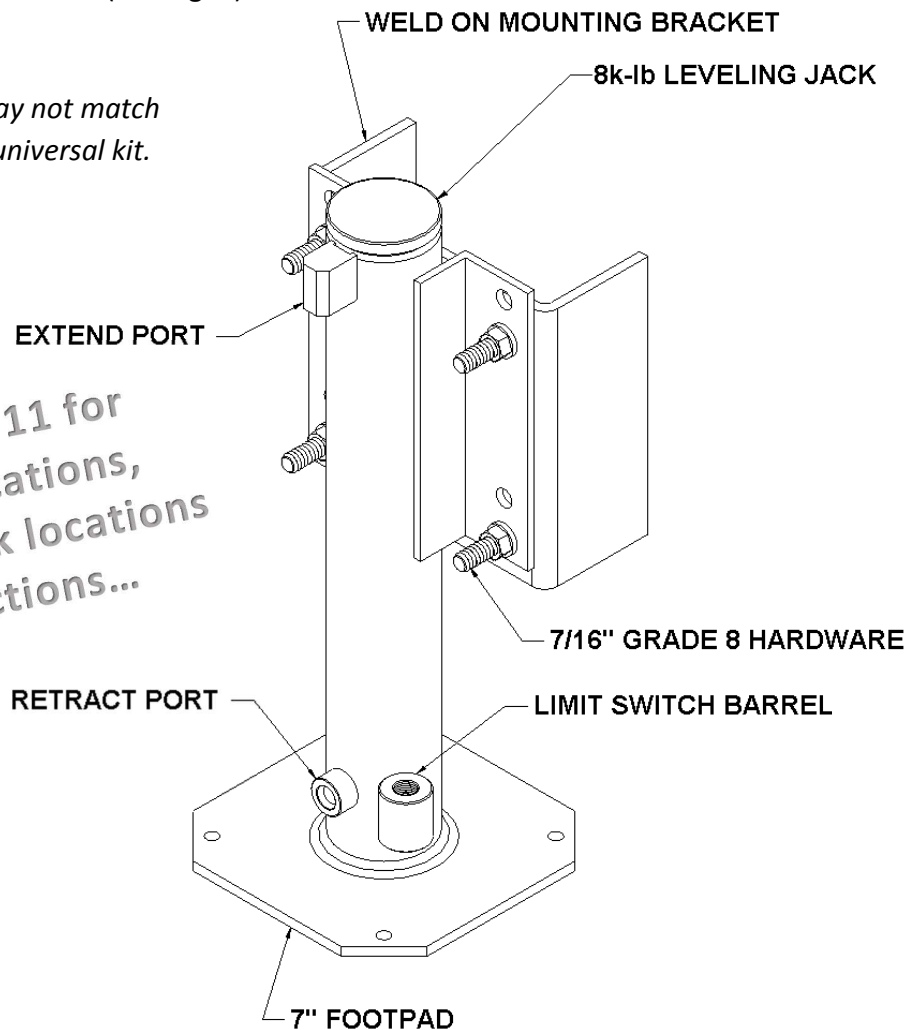

Vehicle: MERCEDES BENZ SPRINTER 3500 CHASSIS CAB

System: Front Jack Bolt-Up Application



Front jack location (under cab) cylinders to be mounted on the outside face of the frame, with the brackets sliding in-between the bottom face of the frame and the bracket labeled "A". See bracket assembly diagrams on the next page for reference, install the lower "L" and upper "L" brackets as shown in the diagram but do not tighten any hardware (brackets should be loose to slide up or down). Place the "Sprinter drill template" in front of the seat base to drill two holes per jack in the cabin floor (see bottom right pic). Before inserting bolts & square washers, apply white primer paint to exposed steel in holes. Occasionally passenger side has a box (shown below) that must be removed.



Vehicle: MERCEDES BENZ SPRINTER 3500 CHASSIS CAB

System: Front Jack Bolt-Up Application -Universal to all 4pt systems

SPRINTER 3500 CHASSIS CAB FRONT APPLICATION

OBJECTIVE: REDUCE/REMOVE FRAME DRILLING, FASTER/EASIER INSTALLATION.

INSTALLATION: DRILL TWO HOLES IN FLOOR PER JACK UNDERNEATH RUBBER MAT FLOORING, BOTTOM "L" BRACKETS SUPPORT LIFT & BACK OF FRAME w/ USE OF CROSSBRACE FOR STABILITY.

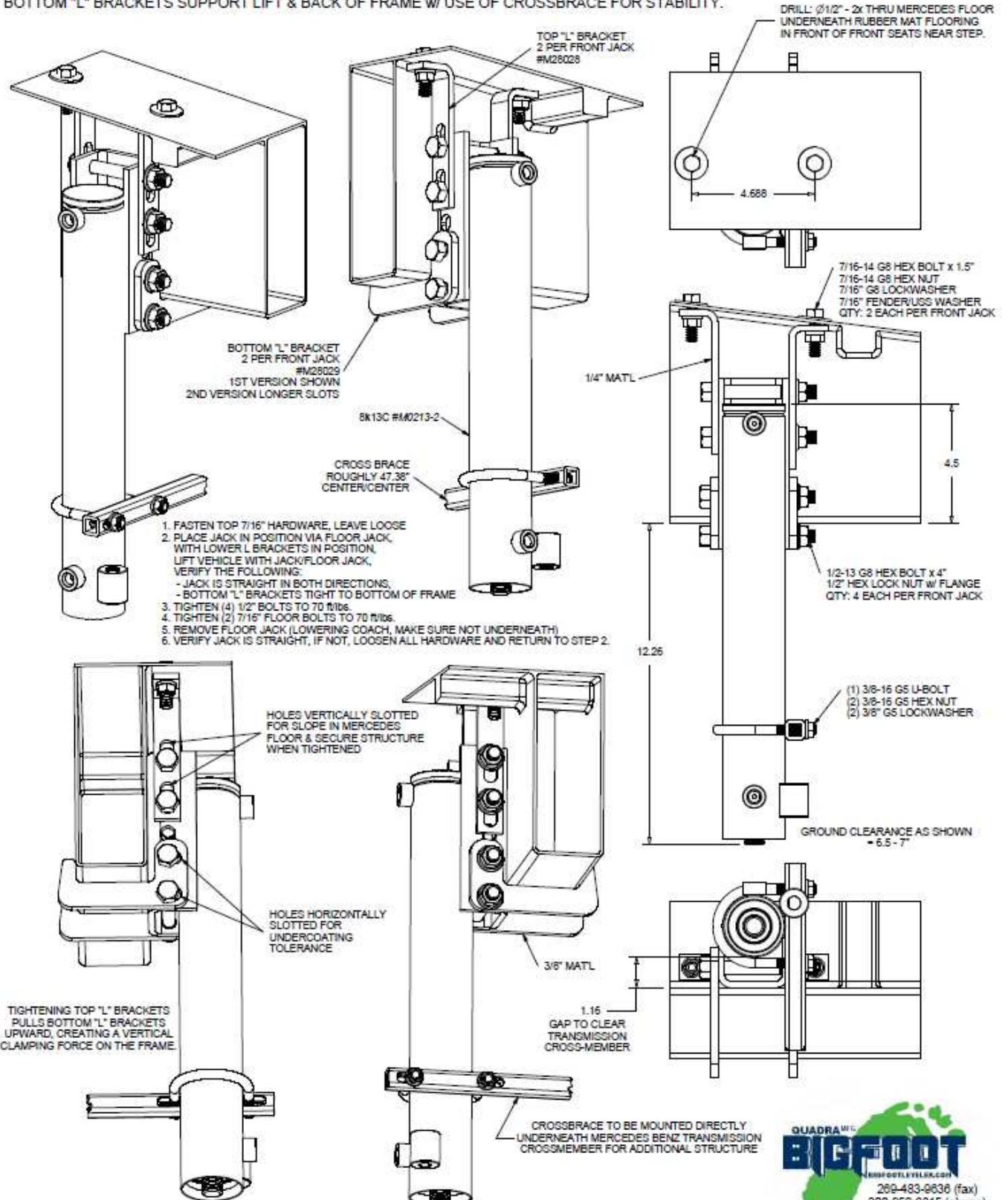

THIS DIAGRAM IS POST PROTOTYPE STAGE, AND HAVE INSERTED UPDATED MEASUREMENTS.

Vehicle: MERCEDES BENZ SPRINTER 3500 CHASSIS CAB

System: Rear Jack Setup for *Channel Series Cylinders* (N/A for all applications)

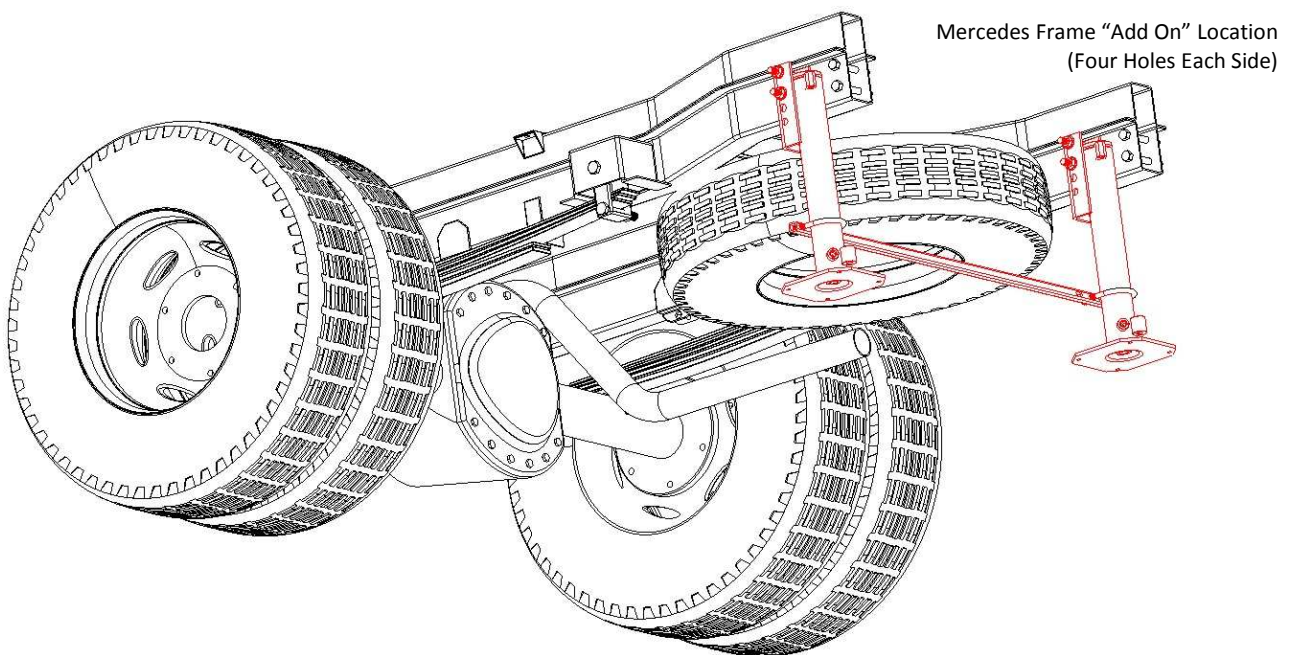

Check your system to see which setup you for the rear. There are two versions, the "Channel Style" shown above and the "Universal Style" which is illustrated on page 9. The Channel Style are the same as the front cylinders. Channel Style system part #'s: #AC-MB4, #PC-MB4, #WC-MB4

Remove old hardware (two bolts per side/per jack), Mount jacks utilizing existing holes by using included longer hardware (1/2" Grade-8 6 1/2" Bolts & Flange Lock Nuts). Tighten to 80 ft-lbs. Crossbrace is required. Either jack can be mounted in-between or on the outside of frame rails if required by the application's interferences.

Components Required:

- (2) #M0213-2 8k13 Rotated Channel Style Cylinders
- (1) #M29623 8k Crossbrace w/ 3/8" Hardware
- (4) 1/2" Grade-8 6 1/2" long Bolts & Flange Lock Nuts

Same components as the Ford Transit 2pt system.

Vehicle: MERCEDES BENZ SPRINTER 3500 CHASSIS CAB

System: *Universal* Rear Jack Setup

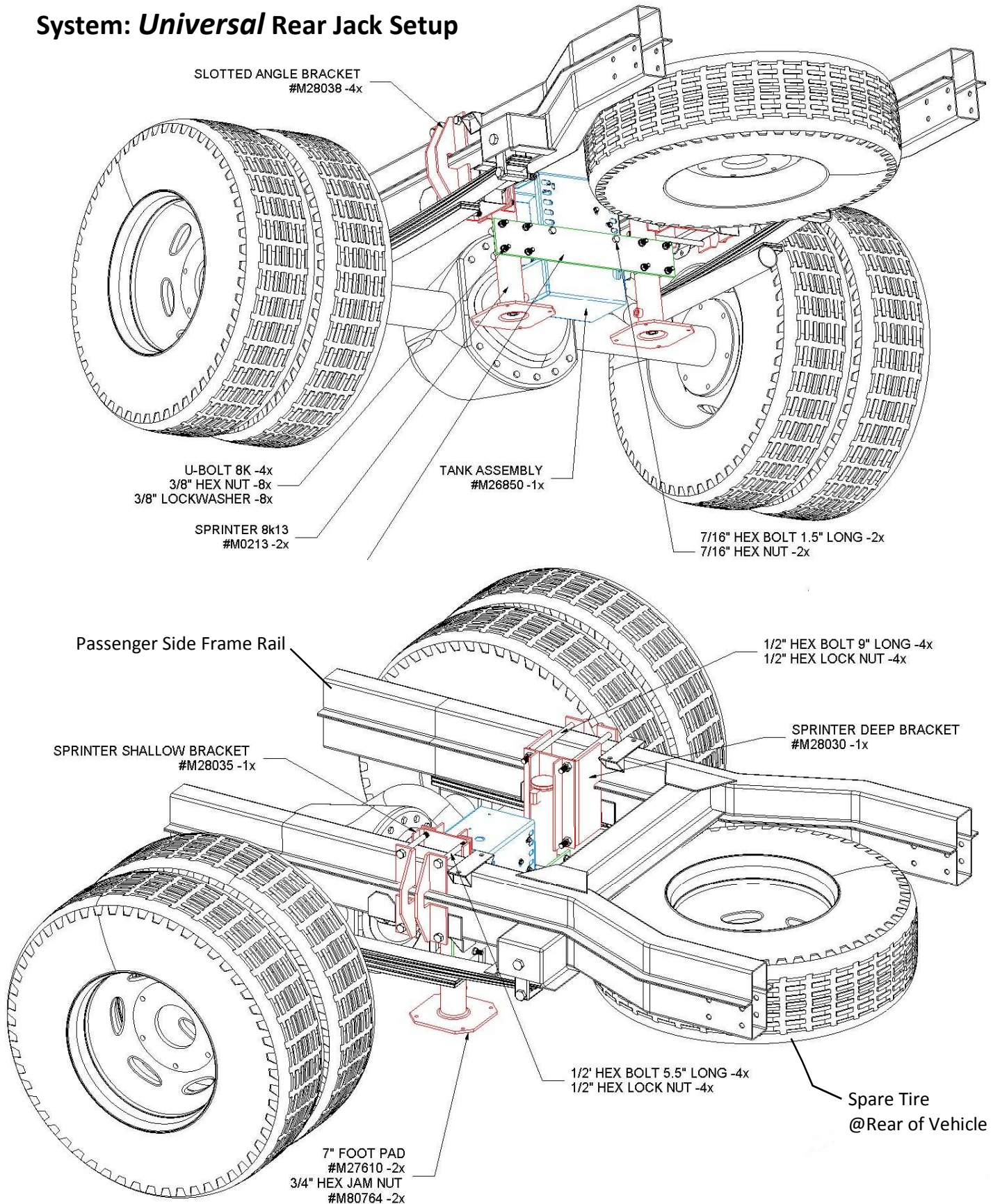

Sprinter *Universal* Rear Jack Setup Continued...

See the diagram on the previous page for locations and visual confirmation on how this system attaches to the vehicle's frame. This is a bolt-on system and requires no drilling or welding.

Cylinder Preparation

Install the Elbow fittings on the lower & top ports of the jacks. Take care not to overtighten and break the fittings, just needs to squeeze the o-ring. You can always check the fittings for fluid or final tightening during bleeding process later on. The foot pads can be installed now or after the jacks are installed. Use the $\frac{3}{4}$ " jam nut, two threads should show past the nut and an impact must be used.

Location

The center of the brackets & jacks should be roughly 15" from center of rear axle, just between the sway bar link bracket and a body mount.

Driver Side

First place the slotted angle brackets and shallow bracket on driver's side frame rail in the location listed above. To hold the two brackets up place two 5 $\frac{1}{2}$ " bolts & $\frac{1}{2}$ " lock nuts (head side to outside of rail) thru the holes as shown in the diagram. Then place the jack (both are the same) on the bolts and have the locknuts ready to keep the assembly from falling. Now place the bottom bolts and nuts thru holes, prior to tightening, assemble other side and crossplate, then make sure jack is level (upright).

Passenger Side

Use the deep bracket & longer 9" bolts & $\frac{1}{2}$ " lock nuts due to the exhaust on this side. Follow the same instructions as the driver side.

CrossPlate

Attach using the supplied U-Bolts, $\frac{3}{8}$ " nuts & lock washers, make sure it is level prior to tightening.

Tank Assembly

Attach facing the rear axle and the lowest holes for the best ground clearance. Use the $\frac{7}{16}$ " bolts, nuts & lock washers. Fill with fluid before the tank cover is installed (see following pages).

NOTE: Installations may require modifications...

Certain vehicles & RV models may require modifications to the following: Weld-on brackets, Extending limit switch wires & battery cables, Re-routing vehicle exhaust and RV plumbing or wiring, Modification to sub-floor brackets or joists, Storage boxes & Floors.

Make sure the proper hardware is used in the proper locations. Everything should be attached and level prior to tightening. All hardware to be fastened to following torque specs:

1/2" (5 $\frac{1}{2}$ " & 9" Bolts) = Torqued to 80 ft/lbs.

7/16" (1 $\frac{1}{2}$ " Bolts) = Torqued to 70 ft/lbs.

3/8" (U-Bolts) = Torqued to 45 ft/lbs.

3/4" (Nuts for Foot Pads) = Impact must be used and one to two threads should be visible past nut.

Vehicle: **FORD TRANSIT 350HD CHASSIS CAB**

Rear Cylinder Location

Complete bolt-on cylinder application, slide the supplied ½” hardware thru factory sleeved holes and thru cylinder bracket as shown. Prior to fully tightening the jacks to torque specs mentioned on the previous page, fasten the cross-brace and verify that the jacks are straight & level.

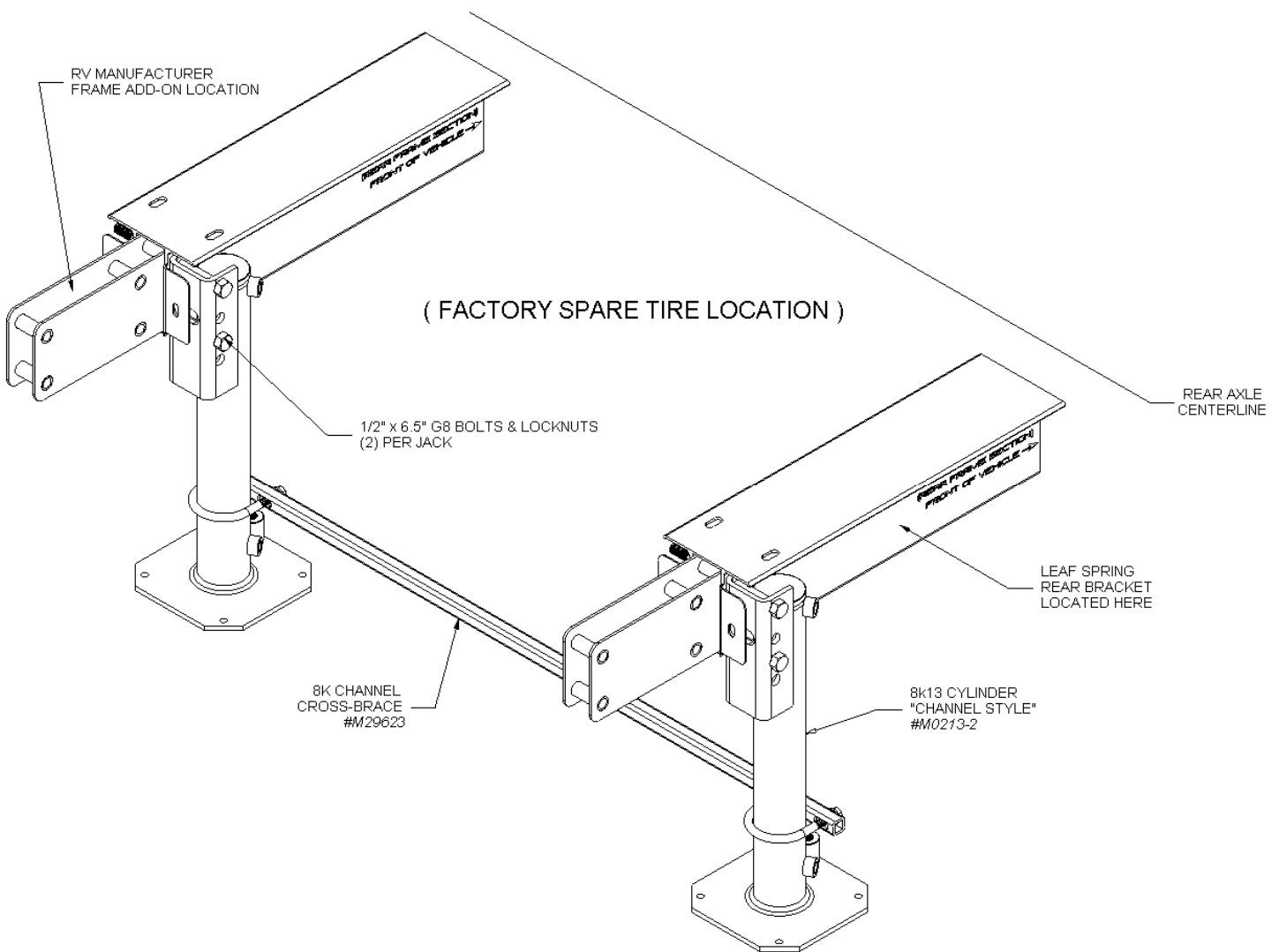

Tank Assembly on Ford Transit Chassis:

This can be mounted almost anywhere outside the vehicle as long as it is upright and away from moving parts or excessive heat. Typical locations include mounting to the RV manufacturer’s frame add-on, or the Ford frame in front of the rear axle on the driver’s side either on the outside of the rail or between the rails, or inside a storage box.

INSTALLATION ON FORD E-450 CHASSIS

FRONT ASSEMBLY UNDER CAB

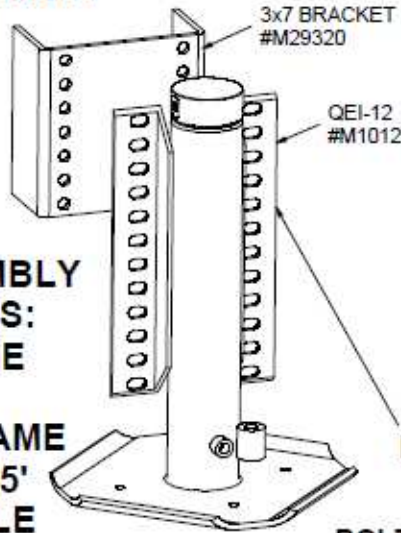

REAR ASSEMBLY TWO OPTIONS: INSIDE FRAME RAIL OR OUTSIDE FRAME RAIL WITHIN 5' OF REAR AXLE

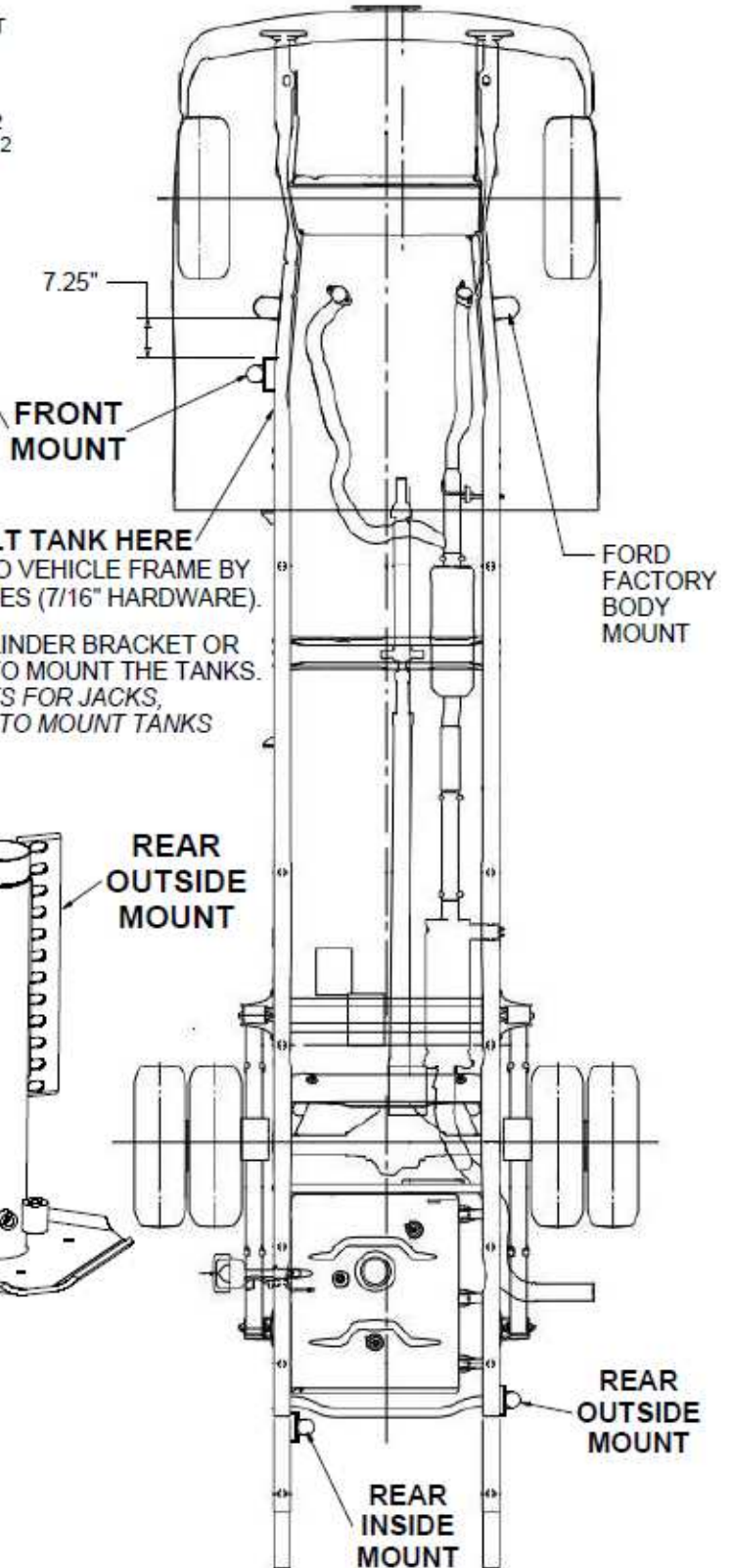

BOLT TANK HERE

FRONT TANK ASSEMBLIES CAN BOLT DIRECTLY TO VEHICLE FRAME BY UTILIZING FACTORY HOLES OR DRILLING NEW HOLES (7/16" HARDWARE).

REAR TANKS MAY BE BOLTED DIRECTLY TO CYLINDER BRACKET OR USE THE OTHER BRACKETS SUPPLIED WITH KIT TO MOUNT THE TANKS.
 EXAMPLE: USED INSIDE MOUNT BRACKETS FOR JACKS,
 USE REMAINING OUTSIDE MOUNT BRACKETS TO MOUNT TANKS

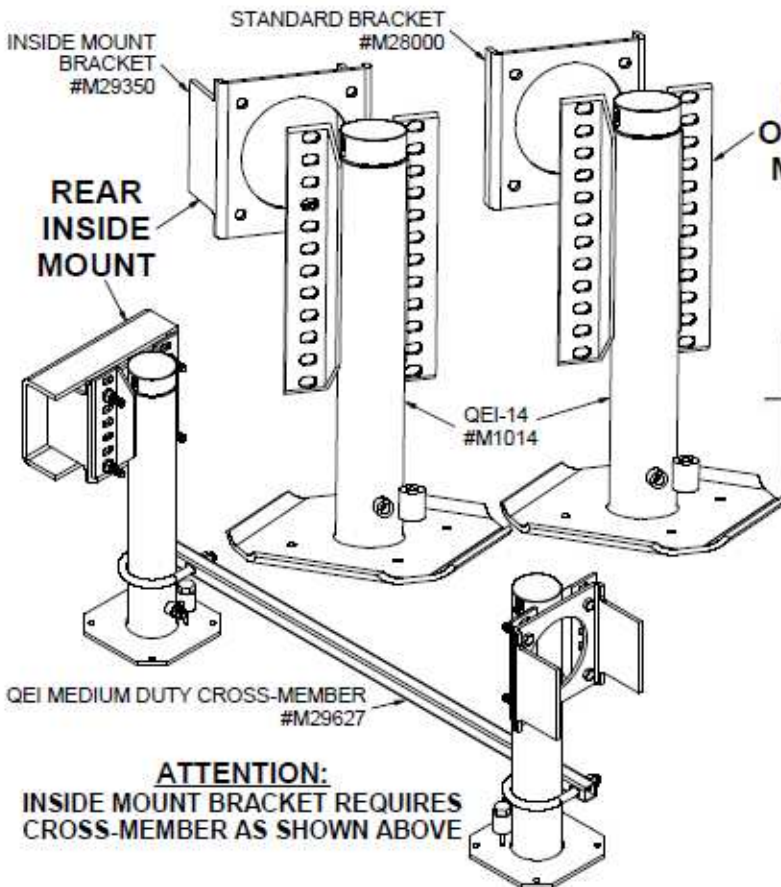

ATTENTION:

INSIDE MOUNT BRACKET REQUIRES CROSS-MEMBER AS SHOWN ABOVE

Cylinders shown above may vary from the system you received... Front: #M0213F, Rear: #M0213R

CHEVROLET 4500 EXPRESS CUTAWAY 4 POINT WELD-ON BRACKET LOCATIONS FOR JACKS

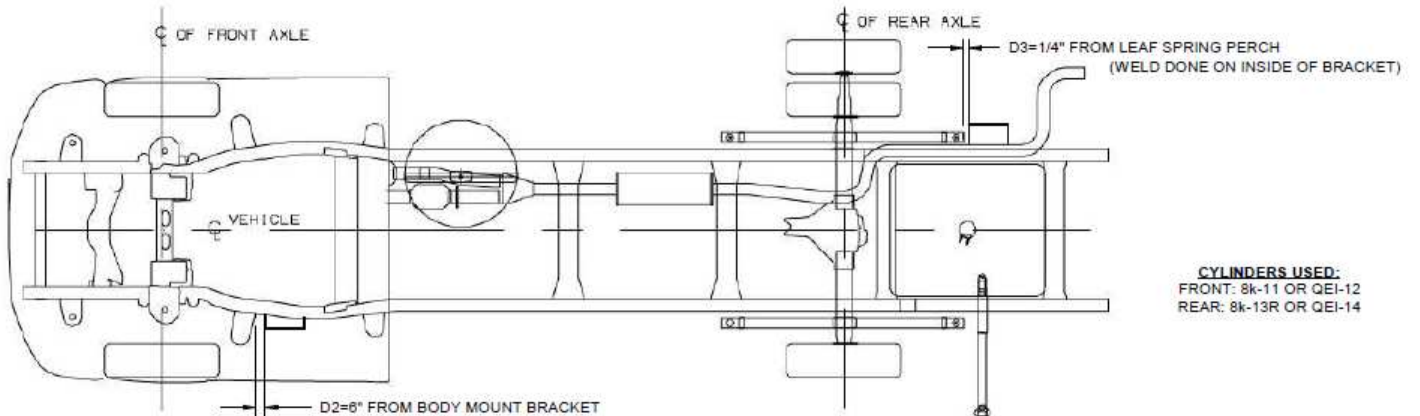

CYLINDERS USED:
FRONT: 8k-11 OR QEI-12
REAR: 8k-13R OR QEI-14

D1 = DISTANCE OF FRONT JACK BRACKET TO THE TOP OF THE VEHICLE FRAME
D2 = DISTANCE FROM FRONT JACK BRACKET TO REAR FACE OF BODY MOUNT BRACKET.
D3 = DISTANCE FROM REAR LEAF SPRING PERCH TO REAR JACK BRACKET

ALL BRACKETS SHOULD BE MIRRORED FROM EACH OTHER FROM PASSENGER SIDE TO DRIVER SIDE.
THESE MEASUREMENTS ARE BASED ON TYPICAL QUADRA INSTALLATION OF FOREST RIVER UNITS.

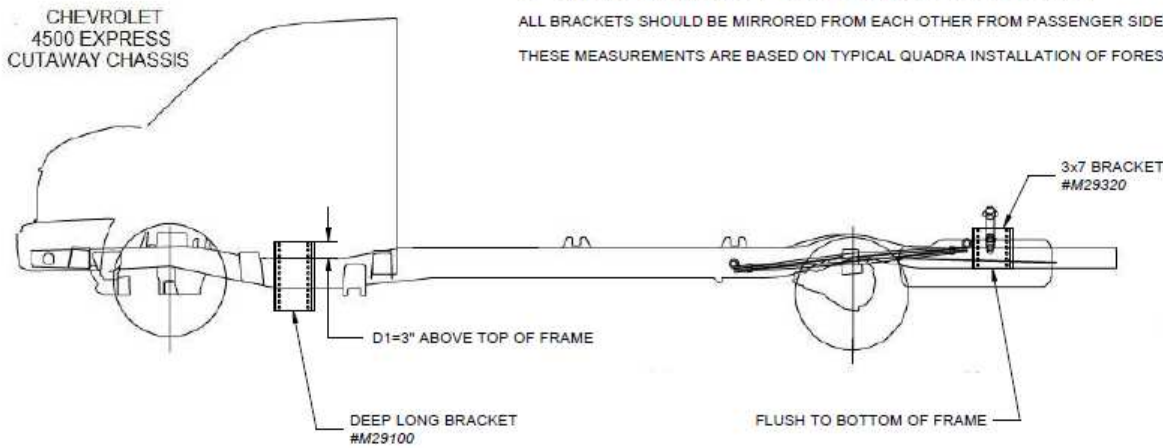

Other Applications: Jack Locations & Mounting

Front jacks under vehicle cab if possible, if not just behind rear cab. Rear jacks within 5 ft from behind the rear axle. When welding the brackets, it may be easier to bolt the jack to the bracket and lift the assembly with a floor jack. Check ground clearances (listed below), straight/levelness of the jack, and check for wires/hoses/etc. that could be damaged during heat of welding. Make sure to get good weld penetration & full length of the bracket/frame. Also when mounting jack, get as much vertical bolt space as the cylinder bracket and weld-on bracket or frame allow.

Typical Jack Ground Clearance

Measured from bottom of foot pad to the ground.

Class B/C/Van: 6 ½" to 8 ½"

Class 8/A/Bus: 10" to 13"

See bottom of page 9 for
possible vehicle modifications
& torque specs...

Vertical Tank Assembly for *Central Pump Systems*

Tank Assembly will be pre-assembled & pre-wired direct from factory.

- Mount the pump using a minimum of two 7/16" bolts, nuts & lock washers.
- Plumbing is shown in Fig. 2 below, use 9/16" wrench and be careful not to under or over-tighten the hydraulic fittings. Sometimes marking the hydraulic lines with tape may make it easier.
- **DO NOT** install the top extend lines to the jacks themselves yet, this will be done later in installation.
- The main wire harness will plug directly into the 14-pin connector that is pre-wired to the assembly.
- Route the **ground harness** (attached to ground shown below) to a grounded surface on the vehicle frame.
- Finally installing the plastic three sided tank cover, this should be done later on in the assembly.
- The tank cover will need to be trimmed to your liking around the hydraulic lines. Fasten the tank cover with at least two self-threading screws, be careful not to puncture the plastic reservoir.

Fig. 2 "A" PORTS
EXTEND

"B" PORTS
RETRACT

RIGHTFRONT <

LEFTFRONT <

RIGHTREAR <

LEFTREAR <

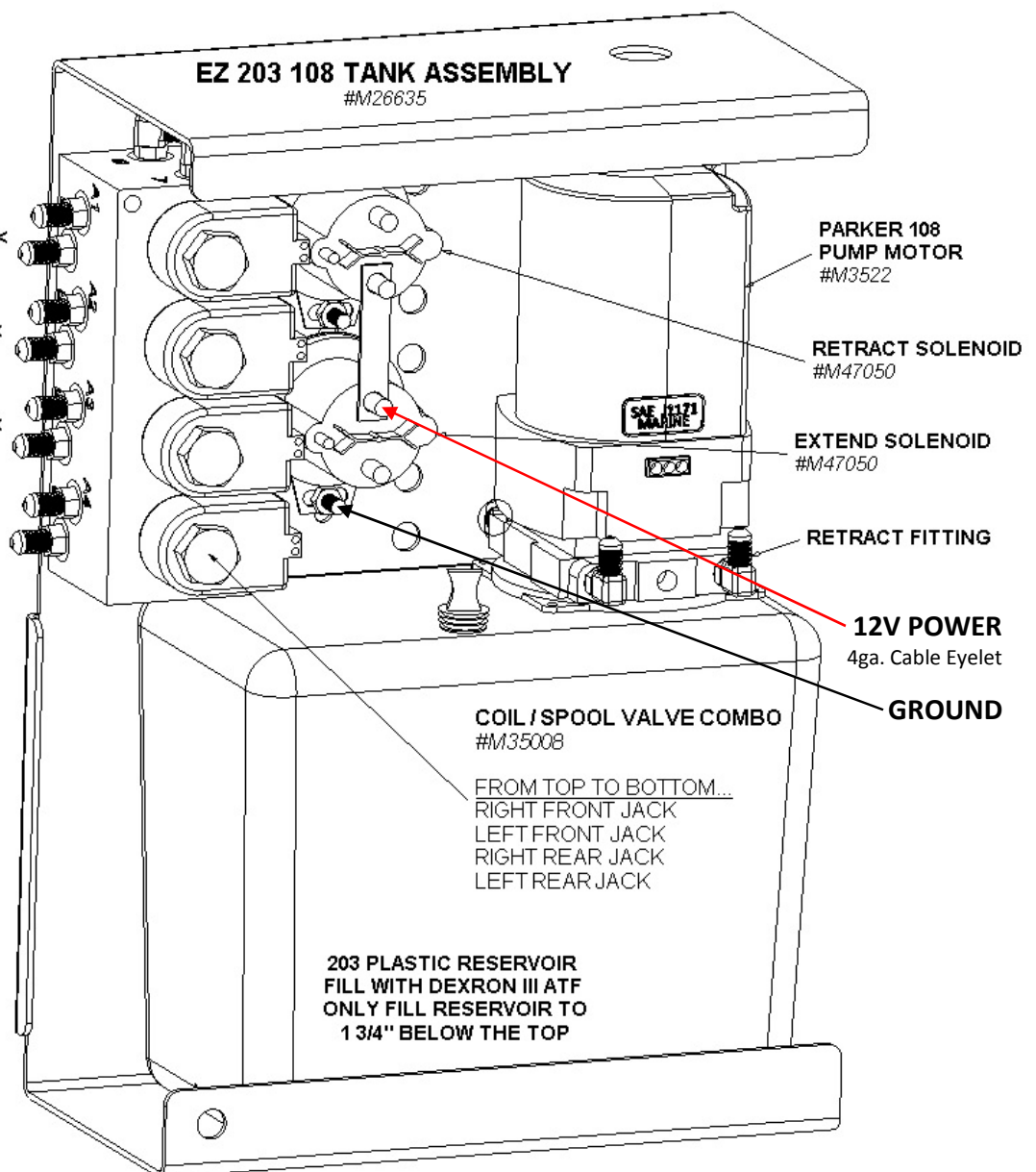

Central tank assembly is typically located near the "center" of the unit, Example: In front of rear axle on driver's side frame rail (outside of rail or between rails).

Horizontal Tank Assembly

192oz. Parker 165 M/O #M26650 CENTRAL TANK ASSEMBLY

Operating Manual Override to retract the cylinders in case of power failure. Power & Ground locations/installation.

SAFETY WARNING!
 MAKE SURE COACH IS ON BLOCKS OR BOTTLE JACK (etc.) WHILE OPERATOR IS UNDER COACH TO RETRACT JACKS MANUALLY!

192 fl oz. STEEL RESERVOIR (ATF DEXRON III)
 MANUAL OVERRIDE 165 MAGNETIZED BI-DIRECTIONAL MOTOR
 INDIVIDUAL MANUAL OVERRIDE VALVES FOR EACH CYLINDER

VALVES FOR EACH INDIVIDUAL JACK FROM LEFT TO RIGHT (BELOW)...
 DRIVER REAR, PASSENGER REAR, DRIVER FRONT & PASSENGER FRONT

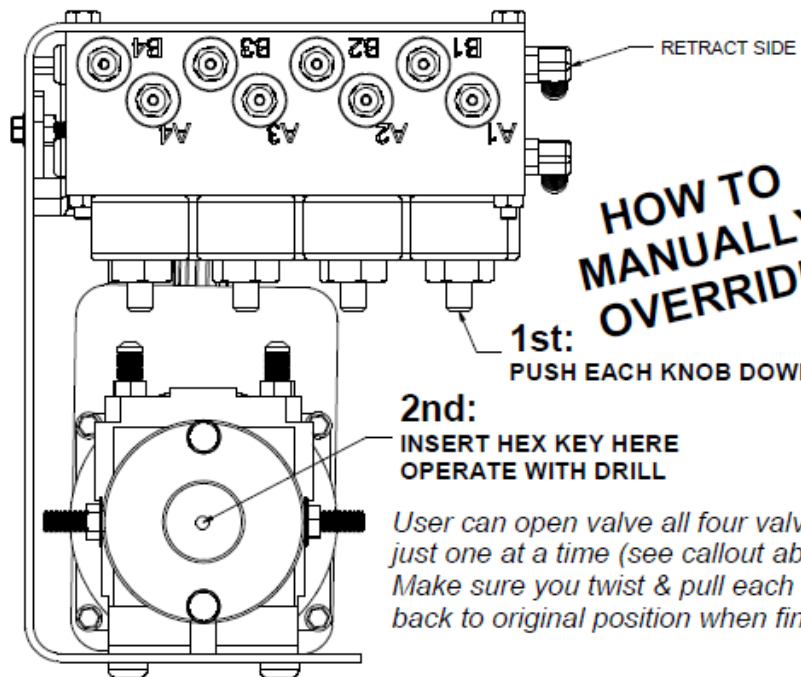
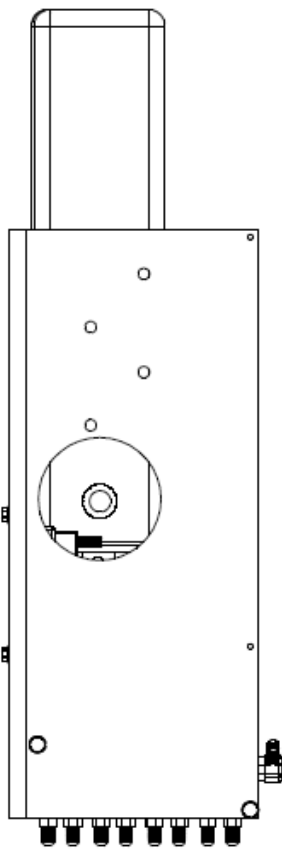

INSTALLATION: 12V & GROUND CABLES

12V POWER STUD ON SOLENOID

-ROUTE RED 2 GAUGE BATTERY CABLE TO POSITIVE TERMINAL ON CHASSIS/VEHICLE BATTERY IF DIESEL, RUN TO HOUSE/RV BATTERY IF GAS CHASSIS.

GROUND STUD LOCATION (UNDERNEATH w/ COPPER STRIP)

ROUTE BLACK 2 GAUGE BATTERY CABLE DIRECTLY TO NEGATIVE TERMINAL ON CHASSIS/VEHICLE BATTERY IF DIESEL, RUN TO HOUSE/RV BATTERY IF GAS CHASSIS.

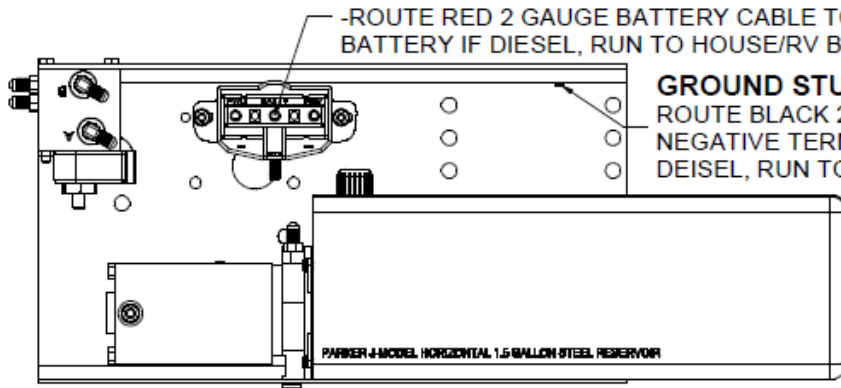

Quad Pump Systems...

MEDIUM TANK ASSEMBLY

#M26850

OVERALL DIMENSIONS:
 9" WIDE
 12.5" TALL
 5.75" DEEP

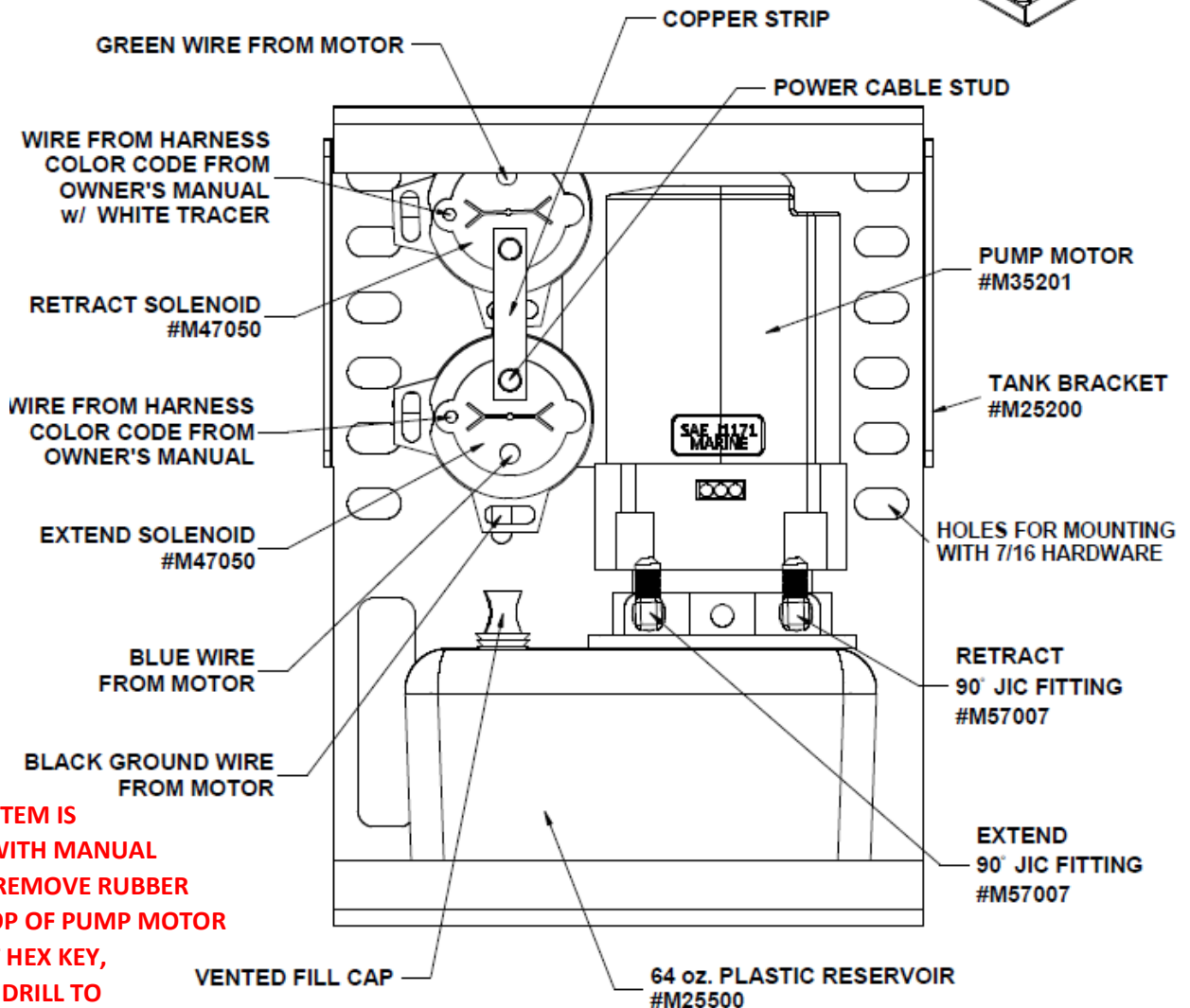
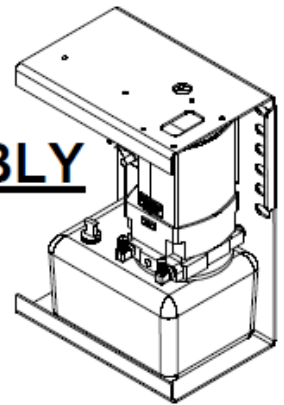

IF YOUR SYSTEM IS EQUIPPED WITH MANUAL OVERRIDE, REMOVE RUBBER PLUG ON TOP OF PUMP MOTOR AND INSERT HEX KEY, TURN WITH DRILL TO OPERATE JACK UP/DOWN

**4 PT WIRING HARNESS COLOR CODE DIAGRAM:
 LEFT FRONT: GREEN/WHITE & GREEN
 RIGHT FRONT: BLUE/WHITE & BLUE
 LEFT REAR: GREY/WHITE & GREY
 RIGHT REAR: BROWN/WHITE & BROWN**

**NOT PICTURED:
 TANK COVER
 (BLACK TEXTURED PLASTIC)
 #M12002**

Mounting Tank Assemblies (Quad or Central)

Our tank assemblies are weather resistant and must be mounted vertically and can be mounted externally on the vehicle's frame by drilling holes in the frame or welding a bracket, tanks can be mounted to a cylinder bracket or inside a storage box. Use at minimum two 7/16" or 3/8" bolts per tank assembly. Take care when mounting and running hydraulic lines & wiring to avoid moving parts, exhaust, etc.

SPRINTER CHASSIS CAB BOLT-ON TANK MOUNTING DIAGRAM

STEP #1

1. FASTEN 7/16" X 1.5" BOLTS, NUTS & LOCKWASHERS, MATING TANK ASSEMBLY & BRACKET AS SHOWN PRIOR TO HANING ON FRAME.

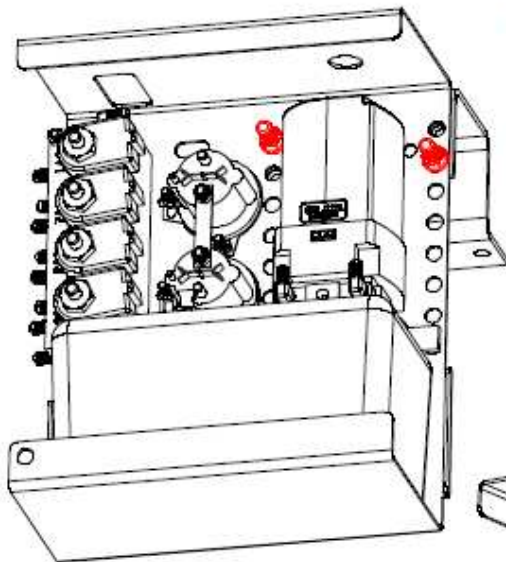

STEP #2

2. PLACE ASSEMBLY ON SPRINTER FRAME, VERIFY BRACKET IS TIGHT AGAINST SIDE AND TOP OF FRAME.

3. FASTEN SQUARE WASHERS TO CLAMP DOWN ON FRAME FLANGE USING 7/16" X 1.5" BOLTS, NUTS & LOCKWASHERS AS SHOWN.

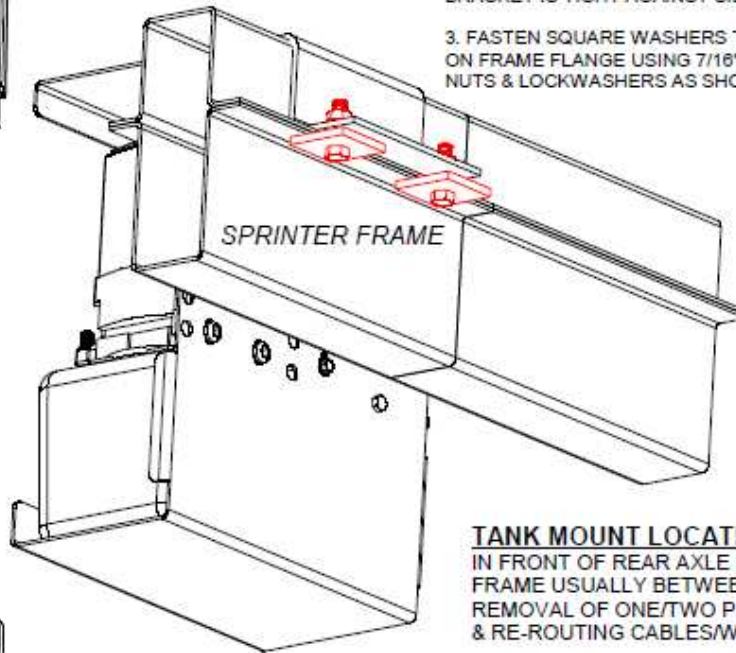

TANK MOUNT LOCATION:
IN FRONT OF REAR AXLE DRIVER SIDE FRAME USUALLY BETWEEN THE RAILS. REMOVAL OF ONE/TWO PLASTIC RIVETS & RE-ROUTING CABLES/WIRING REQ'D.

FIG. #1

MB TANK MOUNT BRACKET #M29313

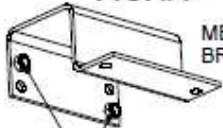

7/16" NUTS PRE-WELDED

STEP #3

4. INSTALL 7/16" X 1.5" BOLTS THRU WELDED NUTS SHOWN IN FIGURE #1, TIGHTEN SO BOLT CLAMPS OR PRESSES THE SIDE OF THE FRAME, LOCKWASHER MAY OR MAY NOT BE USED WITH BOLT DEPENDING ON HOW TIGHT THE BOLT CLAMPS THE ASSEMBLY TO THE FRAME.

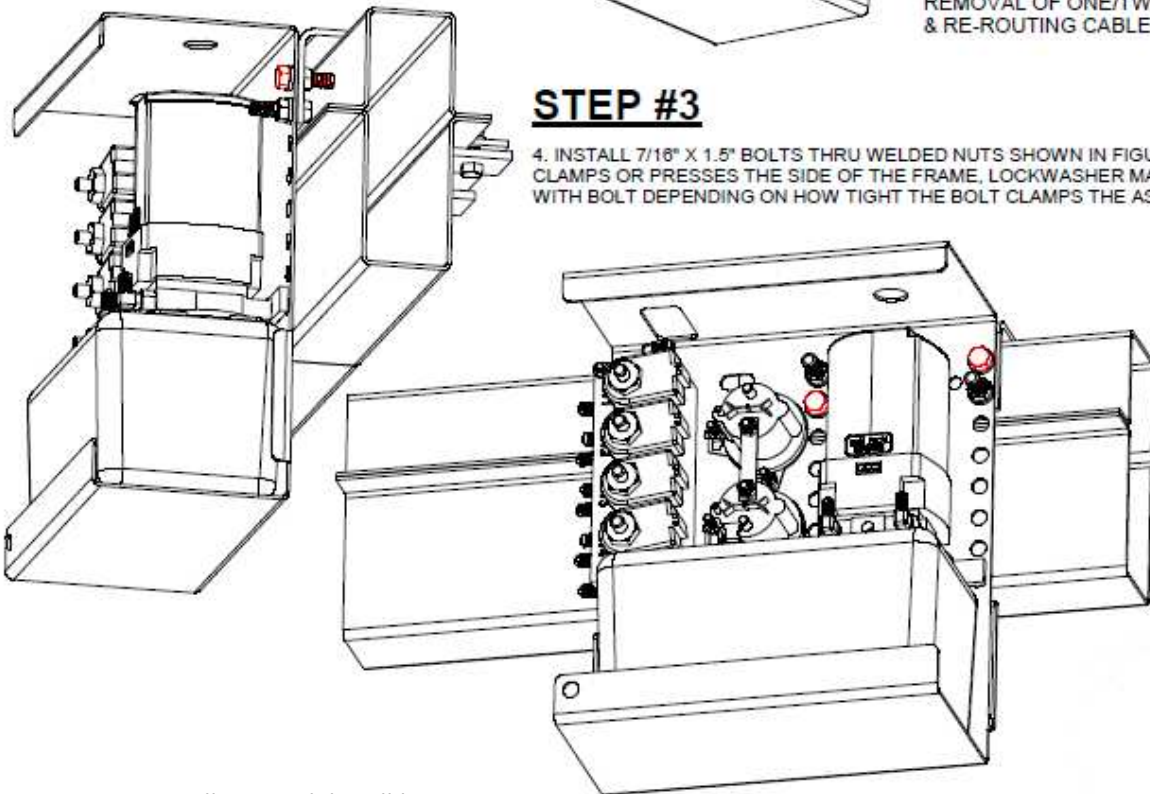

NOTE: Not all RV models will have space for this bracket, sometimes the tank assembly must be located in a storage box or another area on the coach.

Grounding your tank assembly...

Each pump requires 12V power and sometimes an additional ground is required for the pump/motor to operate correctly. This is true for central pump, quad pump and 2pt systems. An auxiliary ground harness (optional) could come pre-wired to the tank assembly, otherwise attach a 10 gauge wire from the location shown below (solenoid mounting stud from each so and to a good grounded surface on the vehicle frame or directly to the negative terminal on the battery. At the bottom of this page is a picture of the Mercedes Sprinter (chassis cab) uni-body ground location in front of the rear axle.

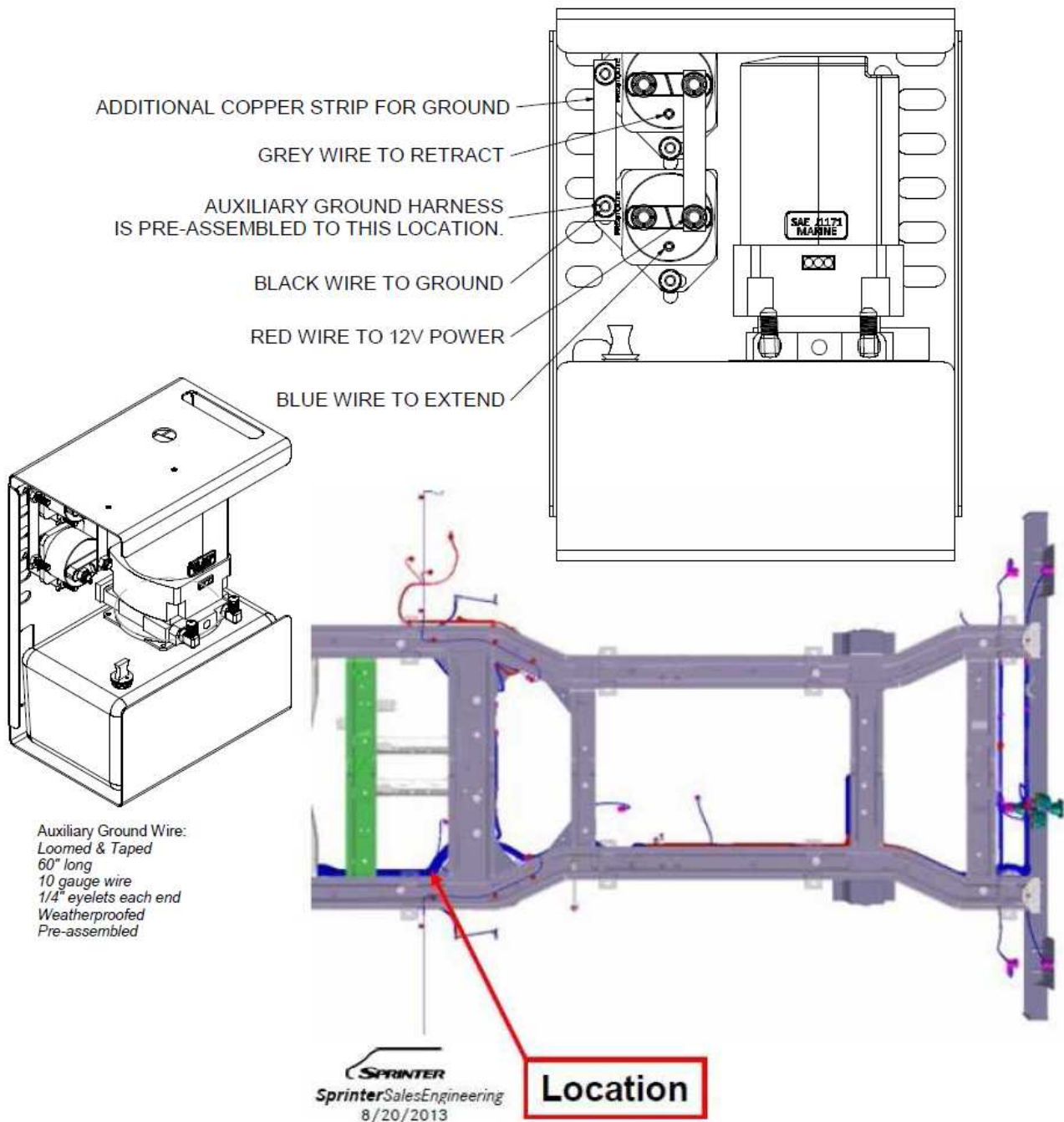

Main Wire Harness –Automatic Leveling & Platinum System

Installing the 14-Pin Wiring Harness Central Pump Automatic Leveling & Platinum Systems

The harness has two ends with plugs; the “panel” end has a 14-pin connector & a 6-pin. This end will need to route to the control panel’s location (usually near front of vehicle near driver’s seat or in wall of cabinet near service door). The other end will have one 14-pin connector that will plug directly into the tank assembly. The rest of the harness has two wires: Black & Tan, both of these wires plug directly into the Limit Switch that you installed previously onto each jack. Attach the wire harness to the frame rail (usually inside of rail with other wiring) with p-clips or zip ties safely routing away from any moving suspension parts or exhaust (complying with RVIA regulations). Example diagram on next page...

Installing the 14-Pin Wiring Harness Quad Pump Automatic System

The main wire harness will have three wires for each corner: One wire goes to the limit switch (has spade connector) (the limit switch has two wires coming from it, the wire with the eyelet goes to ground, the spade connects to harness). The other two wires (same color except one has a tracer) have female push-on connectors that plug into the operation posts on each solenoid. The battery harness has eyelets at each corner that attaches to the power stud on the lower solenoid (with the copper strip). See the “Medium Tank Assembly” diagram earlier in the booklet. The main harness lead has a 14-pin connector at the end, this end will need to route to the sensor location. Attach the wire harness to the frame rail (usually inside of driver’s side rail with other wiring) with p-clips or zip ties safely routing away from any moving suspension parts or exhaust (complying RVIA regulations). Example diagram on next page...

Installing the Limit Switches to the Jacks

Central Pump systems, both wires from limit switch plug into harness.

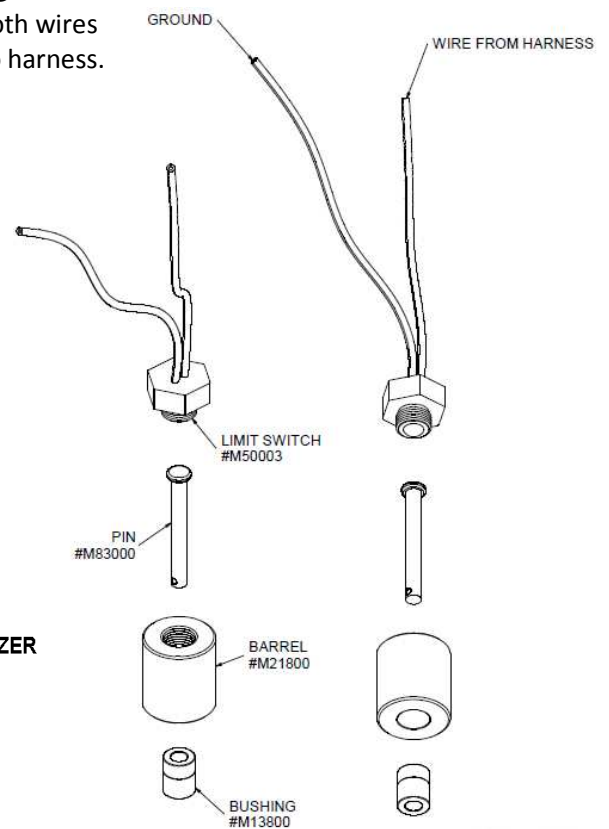

The **Wireless System** does not have a main wire harness that goes to each jack from the controls, but it does have an optional all-up safety feature complete with limit switches that is routed to each jack. This harness routes to the All-Up indicator that should be mounted near the driver inside the vehicle. The Limit Switch harness has two wires that go to each jack, one green & one black, each wire goes to the wires from the limit switch shown on the right. Wiring the lead wire to the all up indicator is shown below.

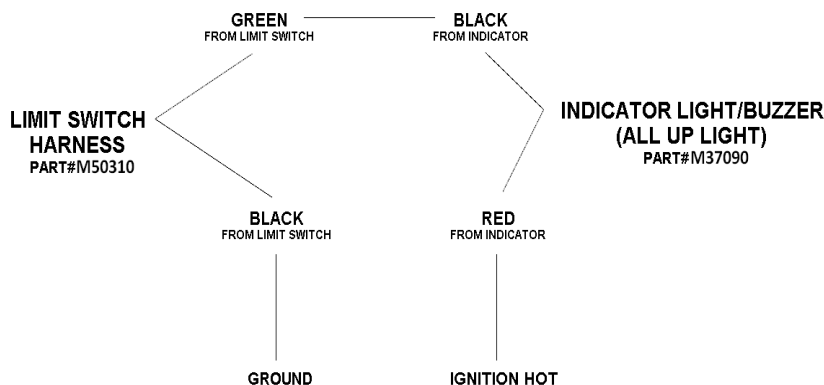

Example below of routing the Quad Pump Automatic & Manual systems 14-pin wire harness. The Central Pump Automatic & Platinum systems harness is similar except that the leads to each corner or jack have only a tan & black wire that plugs into the limit switch and the end of the harness with the 14-pin connector plugs into the pump while the end with the 14-pin & 6-pin connectors plug into the Automatic's Sensor or Platinum panel. Take care to avoid high heat areas and moving parts.

MAIN WIRE HARNESS DIAGRAM

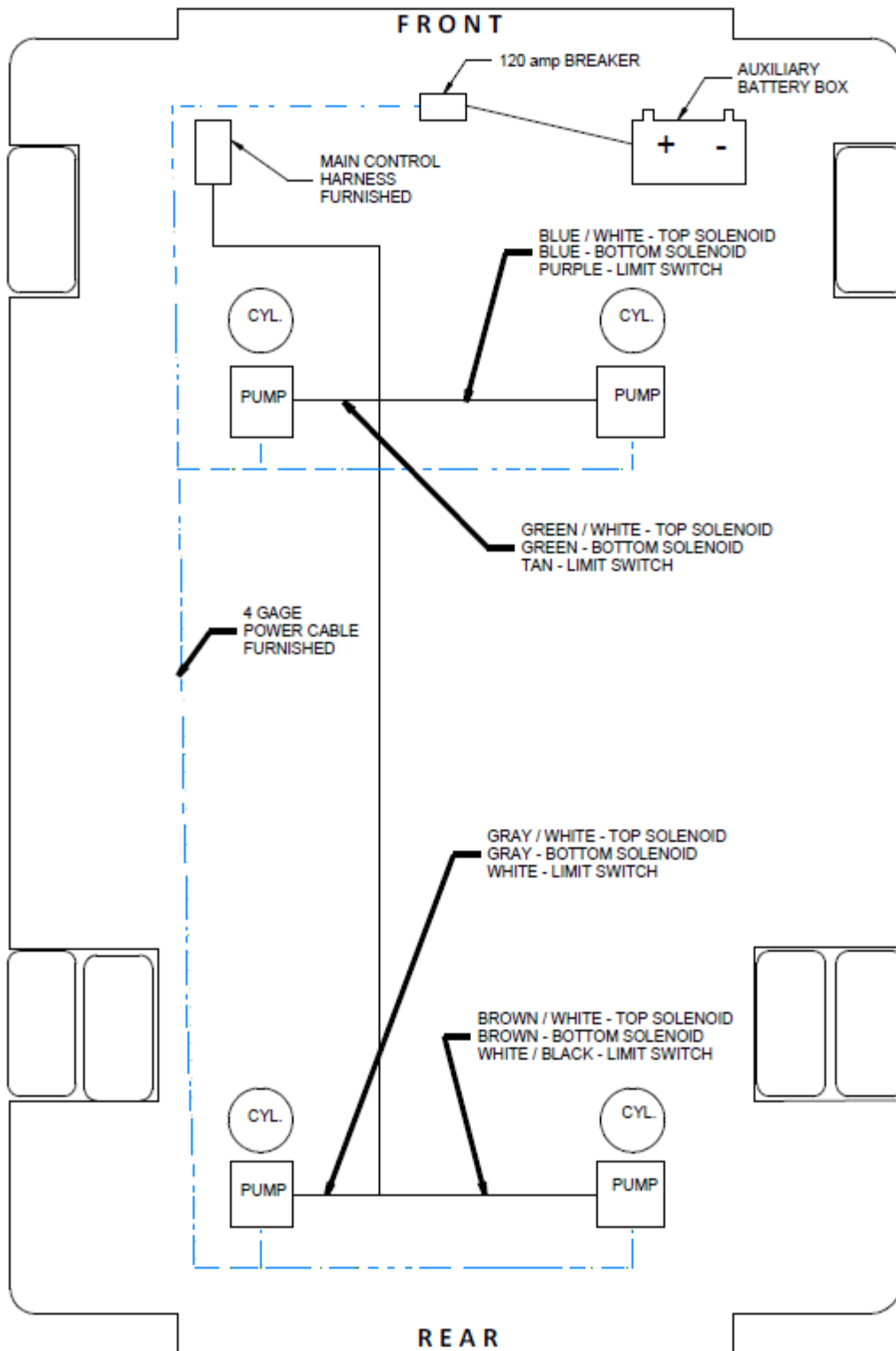

Mercedes Sprinter & Ford E-450 Wiring see pages 28-29

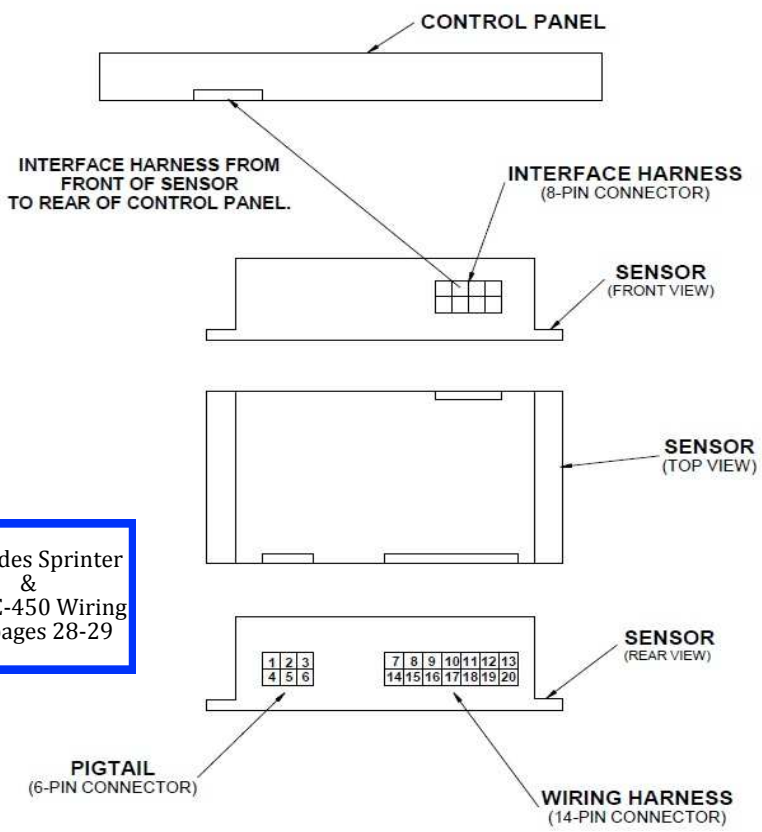

Installing the Automatic Leveling Sensor & Control Panel: Fasten the sensor to a secure structure (usually the floor) inside the vehicle (not weatherproof) ensure that it is mounted level and the arrow on top of the sensor is facing the correct way. Plug the 14-pin & 6-pin from the harnesses into the back side. The 6-pin connector only has three wires that need to be hooked up: red, yellow and black. The yellow wire needs to tie into an ignition or accessory hot wire from the vehicle. The red wire needs to attach to a factory fused 12V power source (7.5 amp fuse). The black wire is ground. After doing so attach the interface harness (8-pin connector) to the front of the sensor and attach to the Control Panel. The panel may be mounted on the dash in a safe location or on a panel somewhere on inside the coach, or inside Quadra’s optional plastic box assembly with the harness loosely coiled underneath the driver’s seat.

Installing the Platinum Control Panel

Plug the 14-pin & 6-pin from the harness into the back side. There is a yellow wire coming from the 6-pin that needs to tie into an ignition hot wire from the vehicle. The panel may be mounted on the dash in a safe location or on a panel somewhere on inside the coach, or inside Quadra’s plastic box assembly with the harness loosely coiled underneath the driver’s seat. **Optional safety feature for Platinum panels**, features an in-line toggle switch to shut power off to the panel to prevent operation while driving down the road from children, etc. Find the red wire from the 6-pin harness that goes to the back of the panel. Cut and splice the included wires to route to the toggle switch that should be located near the Platinum panel for convenience.

Battery Cable Installation for Central Pump & 2pt Systems

Supplied will be a 4 gauge battery cable that needs to be cut into two pieces.
 - The 1st to run from the Solenoid power stud (marked BATT+) to the 80 amp breaker AUX stud.
 - The 2nd to run from the BAT stud on the breaker to the Positive Terminal on the coach’s house battery.
 Hooking up the power should be the final wiring step so make sure this is done after all the other electrical work is done for safety. The supplied 80 amp breaker should be securely fastened in the battery box.

Battery Harness Installation for Quad Pump Systems

Supplied will be a 4 gauge battery harness that must be ran from the coach’s house battery to all four pump assemblies at the solenoid power stud (with the copper strip). For the end going to the breaker read below:
 - Mount the 120 amp breaker near the battery (usually in the battery box) cut a piece of the battery harness off that is long enough to reach the battery from the breaker.
 -Install the eyelet to the now open end of the battery harness and hook it to the BATT post on the breaker.
 -Install the eyelet to the short cut piece and hook that to the AUX post on the breaker and to the positive terminal on the coach’s house battery. Hooking up the power should be the final wiring step so make sure this is done after all the other electrical work is done for safety.

Installing the Manual Control Panel: Plug the 14-pin harness & 6-pin into back of panel, mount with bezel.

Installing the Wireless Receiver

Mount the Wireless Receiver near the tank assembly, check and plug the wiring connector from the receiver to the tank assembly to make sure it reaches, the Receiver is weatherproof but be aware of possible road debris, clear of exhaust and other moving parts.

Central Pump Final Extend Hose Installation & Bleeding the System

During installation of the hydraulic lines, air is internally captured in the hose. Due to this, bleeding the air out of the system is necessary for the system to work properly. This process is done at the end of installation and requires two people and can be messy, so as a warning make sure you are wearing eye protection and have rags ready to use. Make sure all hose fittings are tight on the pump side and the retract side of the jacks. Extend hose fittings should still be un-installed.

- With person #1 running the panel, go into Manual Mode, all jacks should be fully retracted.
- Person #2 (armed with a 15mm wrench, safety glasses, rag and a one gallon container) needs to access the left rear jack and place the un-attached extend hose into the empty container.
- Now person #1 will extend that left rear jack from the panel (press & hold button).
- Fluid & air will be spilling out of the port, once a solid stream of fluid occurs, person #1 will release the button on the panel, after fluid stops flowing person #2 should install the hose fitting to the jack.
- Repeat these steps with the rest of the jacks.
- After doing so, extend all jacks fully and let stand for 15 minutes.
- Then retract all the jacks and remove the tank cover and check your fluid level to verify the fluid in the reservoir is around 1 ¼" below the top (ATF Dexron III) do not fill to the top!

Finally install the tank cover, check that all hardware is tight, the sensor is facing the correct way and is mounted level and the house battery is fully charged.

In some instances, the front jacks may need to be dis-mounted from underneath the cab to access the top extend ports during the bleeding procedure.

Bleeding Quad Pump systems

In Manual mode, extend all four jacks to complete extension and leave in this position for 20 to 30 minutes. This pushes all the air out of the lines by weight pressure. After turn panel back on and press Retract.

Troubleshooting - Hydraulic Cylinder/Plumbing Related

What fluid do we use in the system? Automatic Transmission Fluid Dexron III ATF

Cylinders running "choppy"... Bleed the system, if central pump system, try quad pump method first.

Cylinders make loud "squeaking" noise while operating... Spray rams with Teflon spray (dry lubricant).

Hydraulic fluid on footpad or on ground around cylinder... Loose fitting or broken hydraulic line.

Cylinders "creep" down or don't hold pressure when lifting/holding coach...

- Check fluid level, Check for leaks in hydraulic lines/fittings
- Possibly plumbed backwards... (Bottom port on cylinder tube connects to right port on pump, etc.)
- Relief Valves have failed on pump motor... replace motor/tank assembly
- Hydraulic seal failure, check for oil around bottom of cylinder or welds... replace cylinder

Troubleshooting – No “All Up” Light

Auto Leveling/Platinum Control: If the “**All Up**” light is not coming on and you hear the **buzzing sound from your panel when the vehicle ignition is on** it might be a limit switch on one of the jacks. After attempting to retract all four jacks from the panel and doing a visual check to verify that the jacks are indeed retracted but the panel has no “All Up” light. The first step is to extend each jack a few inches and individually retract one at a time. Sometimes the foot pad retracts crooked and doesn’t fully engage the pin. If that doesn’t work, with the jacks fully retracted, press the RETRACT button on the panel and manually pull each limit switch pin up to see if that engages the switch, if the panel shuts the pump off then that limit switch is not engaging properly. To fix this, it could be the foot pad is loose, remove & re-tighten the ¾” nut with a 1 1/16” socket with an impact wrench. If this does not work you can get a “vacuum cap” at your local hardware store for the ¼” diameter pin which extends the length of the pin and completes the circuit.

If you have an “All Up” light but your jacks are NOT fully retracted, we call this a false all up light, this means you have a bad limit switch (they can stick in the “passing” position due to build-up of road debris or rust).

To get you out of a jam or to bypass this... Central pump systems: disconnect the wires to the limit switch, and plug the two wires from the harness that usually go to the limit switch and plug them into each other (black & tan wires) this closes the circuit and allows the jack to be retracted. Quad pump systems: connect the colored wire from the main harness and connect it to the ground wire from the limit switch (or to frame).

Troubleshooting - Continued...

(Auto Leveling) If the **LEFT & RIGHT** lights are flashing that means the program “timed out”, which may mean the coach is on too un-level ground or there was too much movement in the coach during the automatic leveling program. Try again.

If rear jacks are hanging too low to the ground with the jacks retracted fully, check underneath the coach and check to see if the jack can slide up one row of holes. If this can be done, make sure you raise both rear jacks the same height and tighten each mounting bolt to 70 ft/lbs. If your coach is equipped with an airbag system, just increase air pressure slightly to raise the coach.

If a single jack on a central pump system is simply not working properly, the **valve or coil** to that particular jack might be bad. To replace, simply call or go online to order part number **#M35008**.

Panel won’t turn on, system won’t run, clicking noise, FRONT & REAR lights flash...

Battery low, panel won’t turn on = coach battery, the system relies on the house battery. The battery needs to be nearly 100% charged for the system to work, it doesn’t make a difference if the coach is new, that doesn’t mean the battery is fully charged or even good. Batteries don’t charge instantaneously, so one can’t just expect to hook it up to a charger and the system will work immediately, if the battery is good, then the unit might have a ground issue. **Auto systems must un-plug/re-plug the interface cable to clear code on panel regardless.**

Panel is on, but pump(s) are not working OR solenoids clicking but pump/motor is not running... Auxiliary Ground Cable

Sometimes required for heavily coated frames, solenoids need a 10 gauge wire to be attached to one mounting stud for both solenoids on each pump assembly (central or quad) that isn’t working properly to the vehicle’s frame for optimum performance.

2pt Stabilizing System: Wireless or Rocker Switch Controls

Wireless Controls



Receiver shown on Left,
Transmitter shown on Right.
Replacement Transmitter #M37098
Replacement Transmitter/Receiver #M37029

Operation:

Depress the on/off button on the transmitter to activate. The blue LED light on the top right corner should turn on. The transmitter should be in the off position when the unit is not in use, but is equipped with a safety feature that shuts off if not being used after 3 minutes.

On the transmitter, press & hold the Extend button to lift your unit to desired height. To lower the unit or fully retract the jack(s) press & hold the Retract button.

The controls on the receiver operate the same as the transmitter.

Sync Transmitter:

This is usually done by the original installer, but if you have an issue or have a new transmitter follow these simple steps...

Make sure the receiver and the transmitter are off. Enter the "learn mode" by pressing & holding the on/off button on the receiver until the LED light starts to **flash quickly** on the receiver then release.

Now press & hold the on/off button on the transmitter until the LED on the receiver becomes **constant**, then release. Transmitter now "learned".

Re-Program Receiver:

If you are having issues with your controller at all try this before calling for service...

With the transmitter and the receiver off, press & hold the on/off button on the receiver, the LED light will start to flash quickly on the receiver but continue to hold until the light starts to **flash slower**, then release. The receiver module is now cleared of all codes.

Now press & hold the on/off button on the transmitter until the LED on the receiver becomes **constant**, then release. Transmitter now again "learned".

To exit this mode press and release the on/off button on the receiver, the light will become constant. Your controller is now re-programmed and cleared of all error codes.

The Wireless control is wired to the tank assembly and wires are color coded to mate to the extension harness (#M43800 if included). The receiver is podded and can be mounted outside the vehicle, but should be placed where it is easily reached in case if the transmitter is damaged or misplaced, typical placement is inside a storage box wall or inside the tank assembly itself.

2nd Gen Wireless 1pt

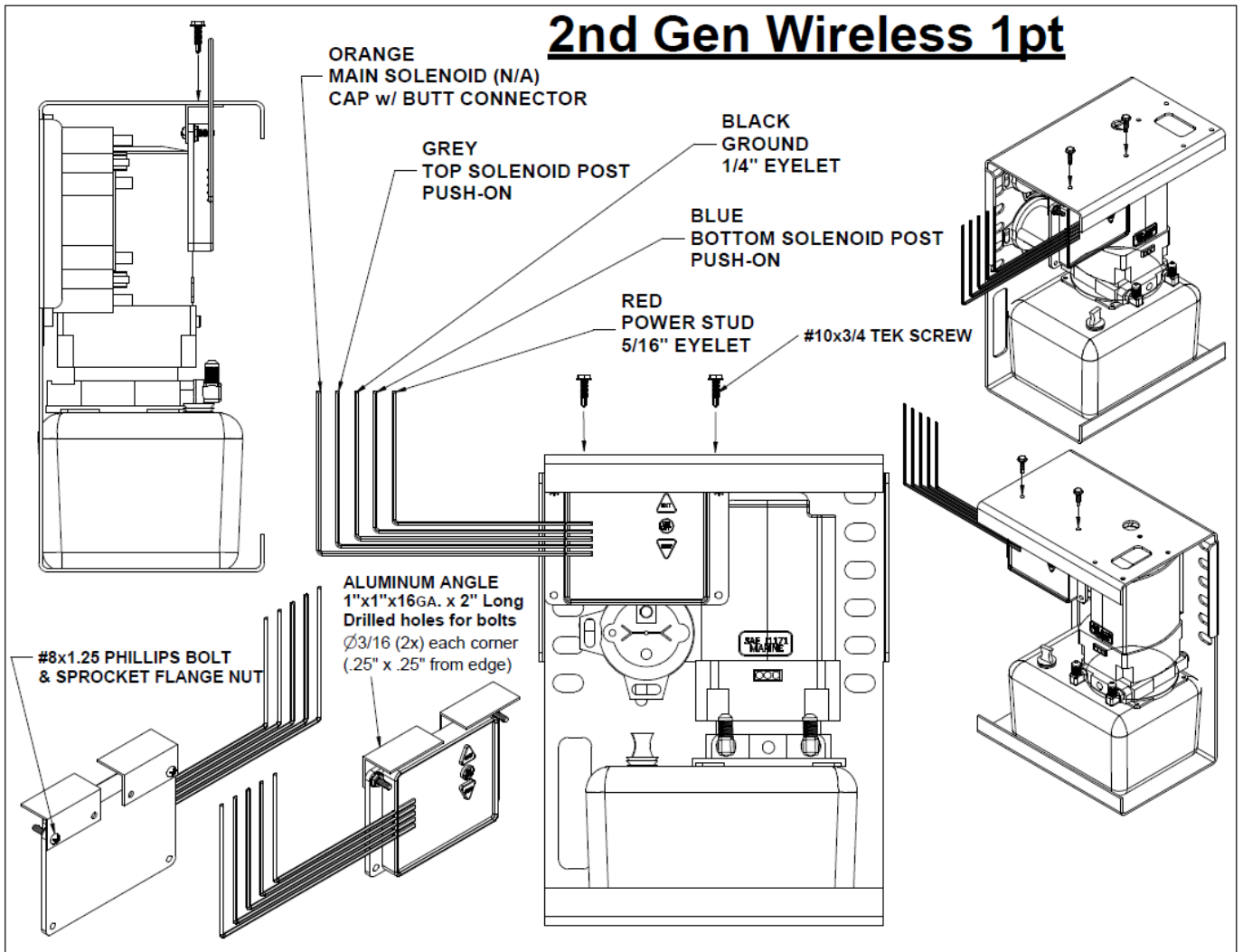

Operating your Jack with the Emergency Controls:

- 1.) Remove cover screws (two)
- 2.) Remove the cover
- 3.) Press ON/OFF switch
- 4.) Press EXTEND or RETRACT

Primary Control for the Jack is your Key Fob, but if that is misplaced, there is still a way out!

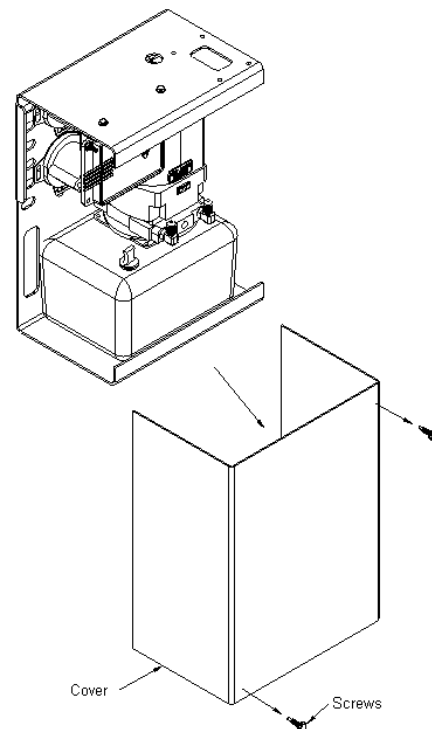
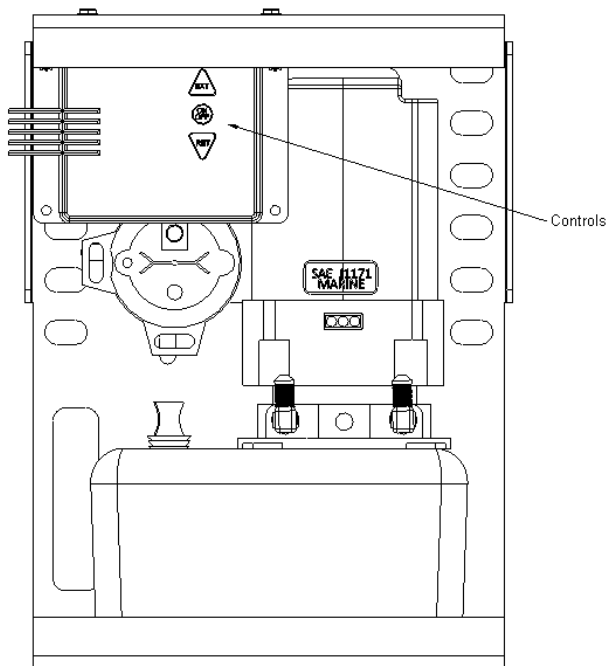

Rocker Switch Controls

Included is a harness (#M43800) that routes from the tank assembly to the rocker control switch. The red wire is the 12V power, this goes from the power stud on the tank assembly (on copper strip with 5/16" studs from solenoids) to the center post on the switch. The black wire is ground & is not needed for this switch. The grey wire goes from the retract operation post on the retract solenoid to the post labeled "1" on the switch. The blue wire goes from the extend post on the extend solenoid to the post labeled "3" on the switch. The switch is not waterproof & must be installed inside the coach.

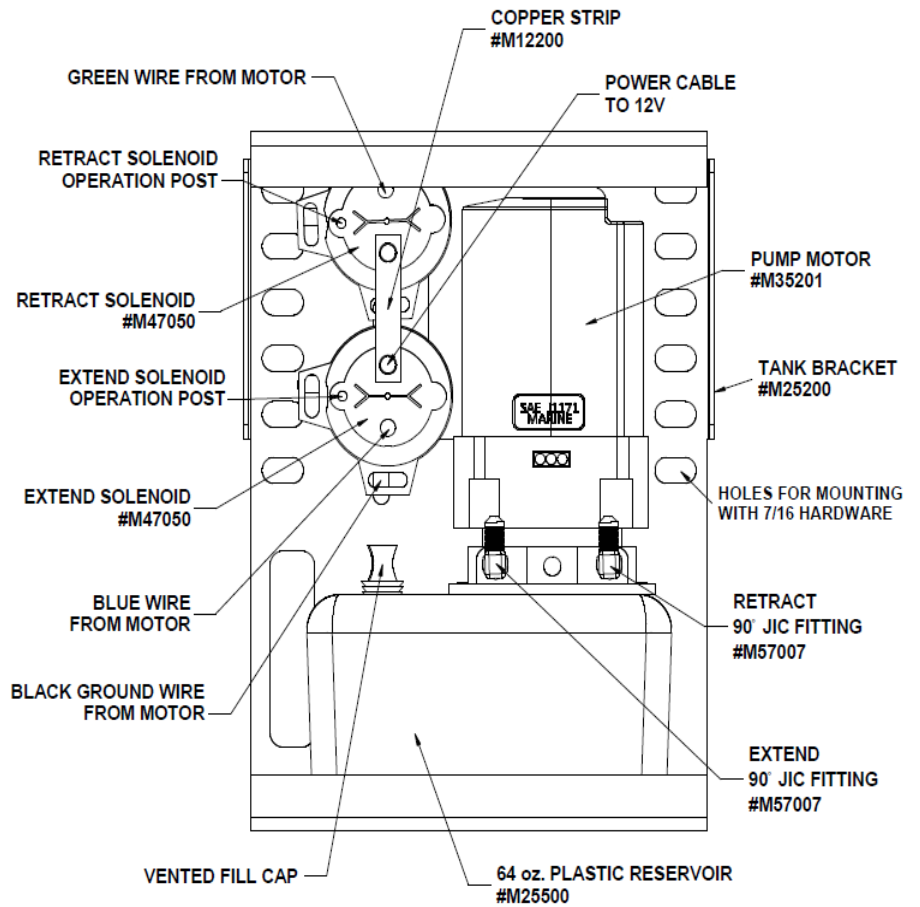

Typical Plumbing

For 2pt "Slave" Systems (one pump, two jacks)

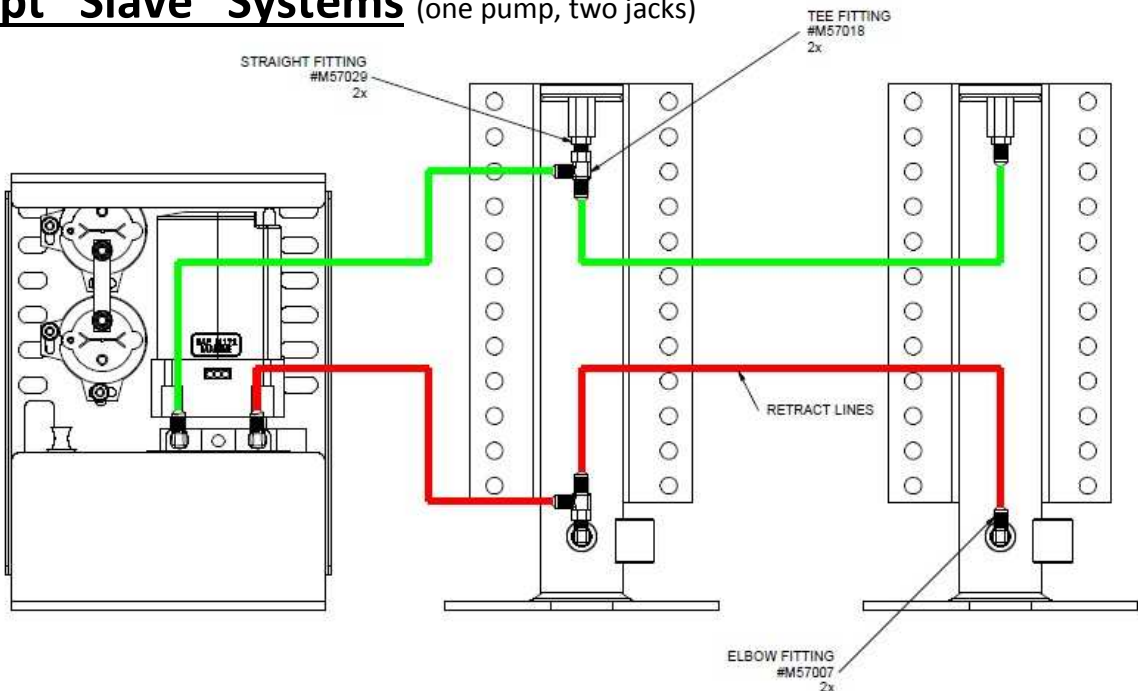

VERSION #1: (SHOWN) THE "TEE" FITTINGS MOUNTED TO THE DRIVE JACK.

VERSION #2: INCLUDES MOUNTING THE "TEE" FITTINGS TO THE PUMP FITTINGS.

VERSION #3: RUNNING TWO LINES FROM THE PUMP AND PLACING THE "TEE" FITTINGS IN-LINE, THEN RUNNING INDIVIDUAL LINES TO EACH JACK FROM THE "TEE" FITTINGS.

2pt Dual Control...

MEDIUM TANK ASSEMBLY

#M26850

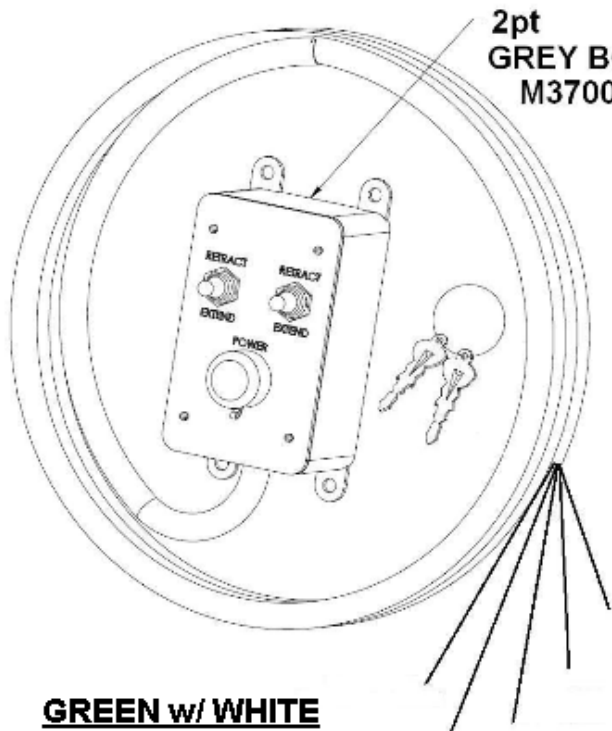

2pt
GREY BOX
M37007

OVERALL DIMENSIONS:
9" WIDE
12.5" TALL
5.75" DEEP

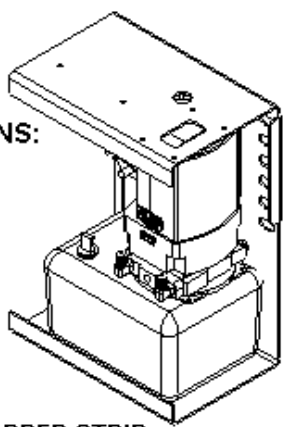

**GREEN w/ WHITE
OR BLUE w/ WHITE
WIRE FROM BOX**
RETRACT SOLENOID
OPERATION POST

**RED WIRE
FROM BOX**

4 GA. BATTERY CABLE
ONE END HERE THEN
TO BREAKER MARKED 'AUX'
THEN FROM POST MARKED 'BAT'
TO POSITIVE TERMINAL
ON BATTERY

**GREEN WIRE
OR BLUE WIRE
FROM BOX**
EXTEND SOLENOID
OPERATION POST

BLUE WIRE
FROM MOTOR

BLACK GROUND WIRE
FROM MOTOR

VENTED FILL CAP

1pt GREY BOX (#M37022)
WIRES UP THE SAME WAY
(ONLY ONE SWITCH & ONE SET OF WIRES)

64 oz. PLASTIC
RESERVOIR
#M25500

EXTEND
90° JIC FITTING
#M57007

RETRACT
90° JIC FITTING
#M57007

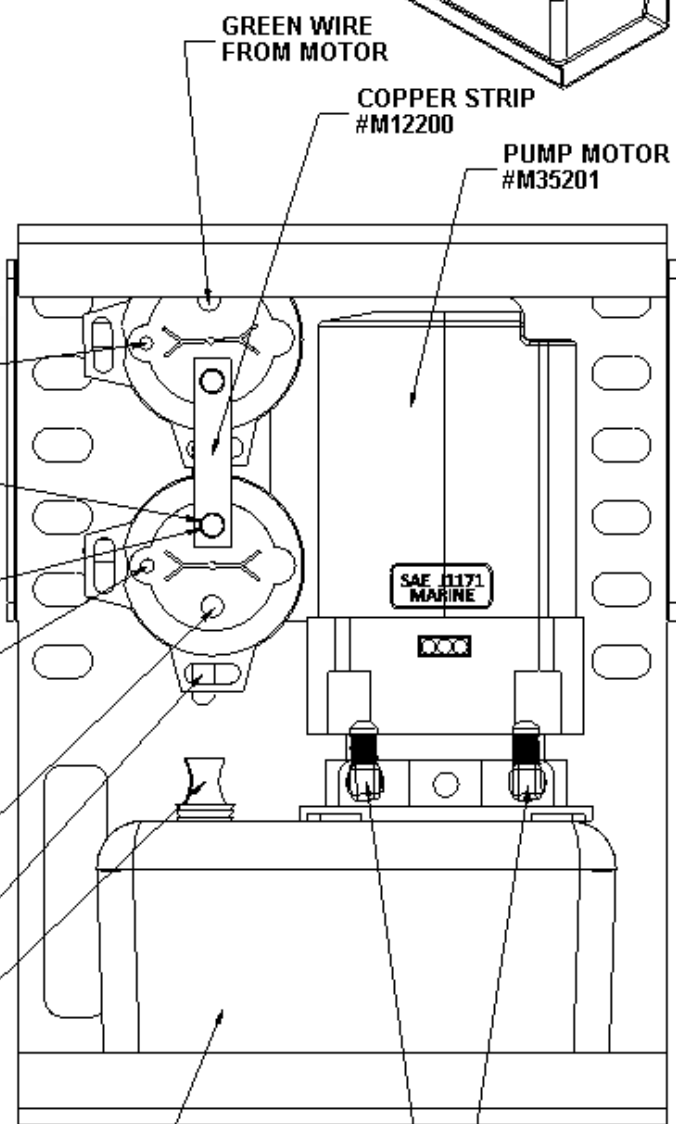

GREEN WIRE
FROM MOTOR

COPPER STRIP
#M12200

PUMP MOTOR
#M35201

SAE J1171
MARINE

NOT PICTURED:

TANK COVER (BLACK TEXTURED PLASTIC) #M12002



5/9/11

Sprinter 3500 chassis cab ignition hot wiring (yellow wire)...

Foam "cover" underneath seat and above seat base, flipped back to expose wiring.



Top surface of driver seat base

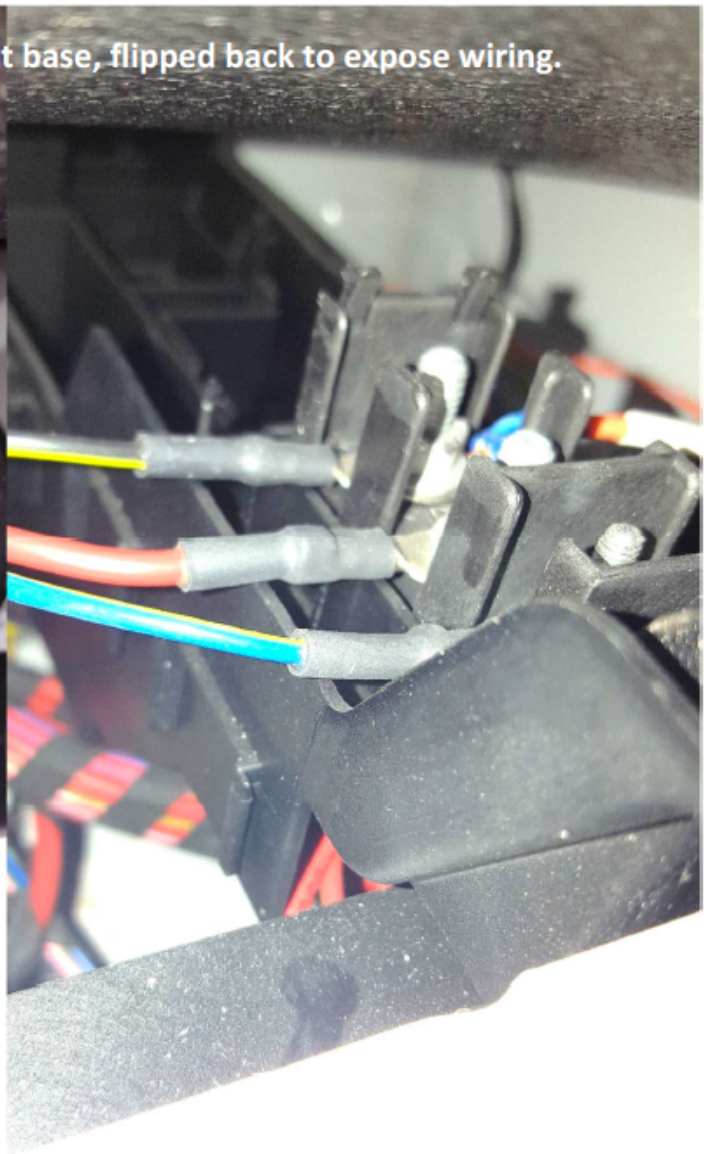

Top surface of driver seat base

Open driver door, facing the outside face of the driver seat, find the steel seat base the seat bolts to. Look at the top of that seat base and flip back a fabric cover from the seat to expose a foam cover over the top of the steel seat base. Flip back cover to expose the wiring shown above. You are looking for the small black plastic case, which can be oriented front to back (pic#1) and left to right (pic#2). Case has a plastic lid that must be opened and flipped back to expose the three posts. As you can see there is one small post and two larger posts. The ignition hot wire is on the furthest large post from the small post, so in pic#1, it is the black with yellow stripe wire, in pic#2 it is also the black with yellow stripe wire. Manufacturer's may use different colored wire, determine ignition wire by the specified post mentioned above not by wire color.

Ford E-450 chassis wiring... Remove plastic step well at driver seat to expose wiring.

Typically: Quadra yellow wire to Ford yellow/orange wire. Quadra red wire to Ford white/red wire.

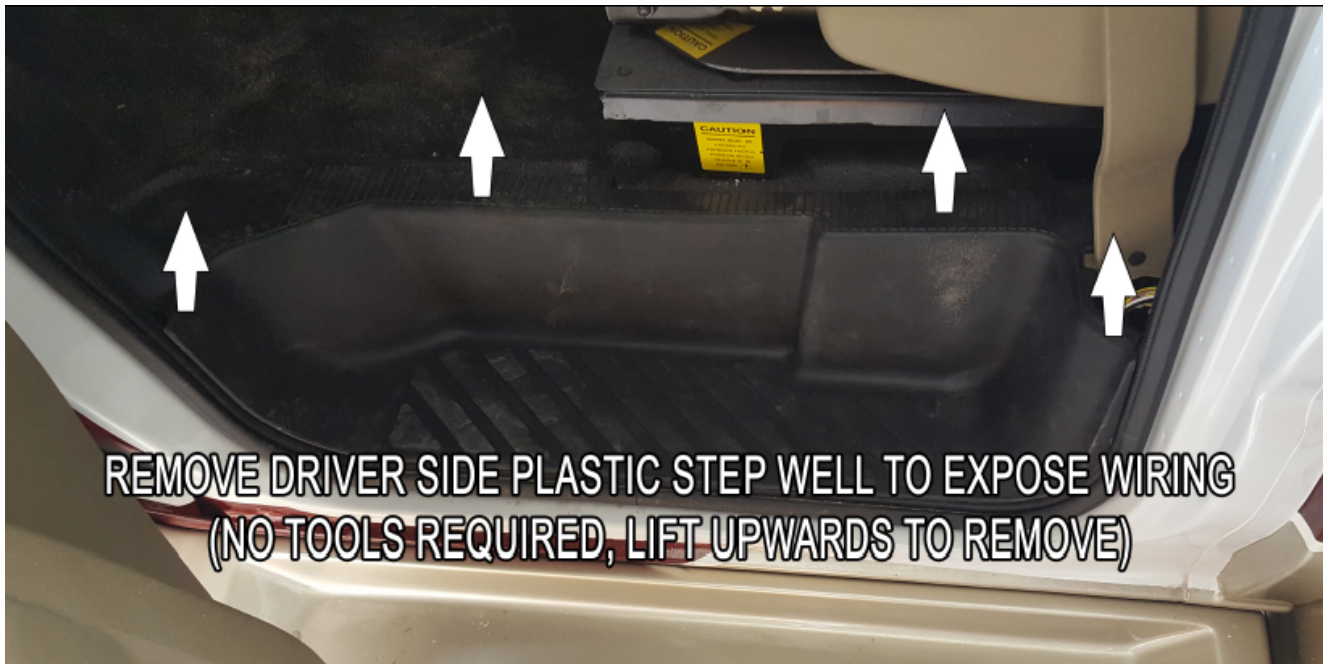

Effective: February 12th, 2018

Warranty Guide

Owner must activate warranty! Via Phone or Website

1-800-752-9815 www.bigfootleveler.com

Platinum Central Pump System: 1 year Cylinders, Parts and Labor
Automatic Leveling Central Pump System: Lifetime Cylinders, 2 years Parts, 1 year Labor
Automatic Leveling Quad Pump System: Lifetime Cylinders, 2 years Parts, 1 year Labor
Manual Leveling Quad Pump System: Lifetime Cylinders, 2 years Parts, 1 year Labor
Wireless Central Pump System: 1 year Cylinders, Parts and Labor
1pt & 2pt Round Leg Stabilizing Systems: 1 year Cylinders, Parts and Labor

Should the product be defective due to workmanship and/or material flaws, we will repair/replace the defective material. Core charges may be applied and refunded on certain components.

Quadra is NOT responsible for:

- Freight on warranty parts.
- Replacing footpads, bolts, or fluids lost as a result of failure to maintain the system (Loose footpads should be tightened at owner's expense).
- Damages caused by abuse, misuse, negligence, misapplication, error of operation, accidental or purposeful damage or faulty installation. Including but not limited to hoses, fittings & wiring components.
- Liability for loss to the vehicle, or apparatus or property, loss of time, manufacturing costs, labor, material, loss of profits, consequential damages (direct or indirect).
- For transportation to and from a service center, onsite service calls to or from the customer, damage from road hazard, loss of salaries, commissions, lodging, towing charges, bus fares, car rentals, fuel expense, telephone charges, inconvenience compensation while repairing or replacing a defective part or material.

This warranty voids all previous issues. Effective date: 2/12/2018

OWNERSHIP MUST BE REGISTERED WITHIN 30 DAYS FROM THE DATE OF PURCHASE TO ACTIVATE WARRANTY. Do it online at BIGFOOTLEVELER.com!

Prior to any work being done an **authorization number must be obtained** by calling 269-483-9633 for Warranty Parts or Service Labor. For full warranty transcript just contact us!

Service labor based on a flat rate schedule determined by Quadra for **authorized** work performed will be reimbursed. This will eliminate much diagnostic time and avoid **refusal of unauthorized claims**. Many problems may be resolved by contacting a Quadra service representative.

Provide the system serial number here _____.

EMERGENCY SERVICE

For after hours emergency service please call our normal office number **269-483-9633** and follow the instructions.