 Good Display	LCD MODULE SPECIFICATIONS	SPEC NO	
	GD567M03-GTI050TN22	REV NO	1.0

Good Display Specifications

Type: 5.0inch TFT LCD module
Model No. GD567M03-GTI050TN22
Description:

- 5.0" LCD with 640 x RGB x 480 dots
- Supports CVBS/Video & VGA input
- RoHS Compliant

Prepared: Xiaoli Lan
Checked: Moon Wu
Approved: Boris Jen
Issue Date: 2010.10.10



Dalian Good Display Co., Ltd.

No.17 Gonghua Street, Shahekou District, Dalian 116021 China
Tel: +86-411-84619565 Fax: +86-411-84619585
E-mail: info@good-display.com
Website: www.good-display.com

 Good Display	LCD MODULE SPECIFICATIONS	SPEC NO	
	GD567M03-GTI050TN22	REV NO	1.0



Contents

1. Notice	-----	3
2. Technical Specifications	-----	3
3. General Specifications	-----	3
4. Ordering Information	-----	4
5. The pictures of the Product	-----	4
6. Setting the TFT LCD module	-----	5
7. Connection diagram	-----	7
8. The interface definition of the A/D board	-----	7
9. Support Display Resolution Mode	-----	8
10. TFT LCD Panel Mechanical Drawing	-----	9
11. A/D Board Mechanical Drawing	-----	10
12. Touch Screen Mechanical Drawing (Option)	-----	10
13. Touch Screen driver board Mechanical Drawing (Option)	-----	11
14. Product Label	-----	12
15. Precaution	-----	12
16. Trouble shooting	-----	13

 Good Display	LCD MODULE SPECIFICATIONS	SPEC NO	
	GD567M03-GTI050TN22	REV NO	1.0

1. Notice: Important Safety Instructions

1.1 The nominal voltage of DC input to the A/D board is 12V, The size of DC current depends on the TFT LCD, audio amplifier, etc. Please note that your AC/DC adapter's output plug need to match the DC input jack, the diameter of the jack is 5.5 mm.

1.2 Before connecting these input/output ports, Video port, it is strongly recommended that your turn off the A/D board and remove the DC 12V plug from the DC input jack.

1.3 Don't put the A/D board into an airtight package. When it works, it will produce a certain heat.

1.4 When assembling it, please use a suitable force; don't distort the PCB and other components.

CAUTION:

Information in this document is subject to change without notice. Please contact us if you have any questions or suggestions

2. Technical Specifications

2.1 Features:

- TFT LCD module: GD567M03-GTI050TN22/XX-XX serial includes:
AD board: JDM567M03, 5.0" Digital TFT LCD: GTI050TN22, Keypad board, Power cable, Video cable and VGA cable, 5.0" Touch Screen: GDT4W05001 (Option), Touch screen driver with USB port or RS232 port (Option)
- DC/ DC Converter, LED Backlight Driver, Video and VGA Decoder All In One
- NTSC / PAL System automatic identifying and converting
- Single Operation Voltage +12.0V (Min9.0V, Max15.0V)
- Support CVBS/Video & VGA Signal Input
- OSD controls: Allow on-screen adjustments of Brightness, Contrast, RGB Auto Color Balance, Reverse, H-Position, V-position
- Support Touch Screen Function (Option)
- This product is RoHS compliant

2.2 Applications:

- Industrial Controller
- Medical Equipment
- Security Equipment
- Simple Function Equipment

3. General Specifications:

Item	Specifications	Unit
Model name	GD567M03-GTI050TN22/XX-XX	inch
Screen size	5.0 (diagonal)	
Display ratio	4:3	
Resolution	640(RGB)×480	
Backlight	LED	
Brightness	200	cd/m ²
LED life time	30000(Typ.)	hr
View angle	50/70/70/70 (U/D/L/R)	°
Input/output interface	Video/CVBS	
	D-Sub 15 pin female for VGA	
	USB (A Type) or RS-232 (DB9 Female) for Touch Screen Driver (Option)	
Display dimension	117.65(W)×88.43(H)×5.7(D)	mm
Active area	101.568(W)×76.176(H)	mm
A/D board dimension	102.0(W)×50.0(H)×7.9(D)	mm
Operation voltage	DC12.0(Typ.) (Min.9.0, Max.15.0)	V
Input current	DC 250±20	mA
Power consumption	3.0	W
Start time	1.8	s
Touch Screen Controller	4-wire Resistive Driver USB/ RS232 (Option)	
Operation temperature	-20 to 70	°C
Storage temperature	-30 to 80	°C
Humidity	5~95	%RH

 Good Display	LCD MODULE SPECIFICATIONS	SPEC NO	
	GD567M03-GTI050TN22	REV NO	1.0

4. Ordering Information

Parameter	GD567M03-GTI050TN22	GD567M03-GTI050TN22/4-02	GD567M03-GTI050TN22/4T1-02	GD567M03-GTI050TN22/4T2-02	Unit
Support Video input	Yes	Yes	Yes	Yes	
Support VGA input	Yes	Yes	Yes	Yes	
Touch panel type	-	4W Resistive	4W Resistive	4W Resistive	
Touch screen interface	-	-	USB	RS232	
Display dimension	117.65x88.43x5.7	117.65x88.43x7.2	117.65x88.43x7.2	117.65x88.43x7.2	mm
Accessory	None	5.0" Touch screen GDT4W05001	5.0" Touch screen GDT4W05001 and T/P Driver with USB port	5.0" Touch screen GDT4W05001 and T/P Driver with RS232 port	
Unit module net weight (including accessory)	0.24	0.26	0.39	0.43	Kg

Packing Information

Box Information			
	Box Tare Weight: 0.06Kg Package Dimension: 23.0x14.0x4.0cm	0.1Kg 24.0x17.0x9.0cm	1.5Kg 52.0x27.0x28.0cm
LCD Modules Capacity (Without T/P Driver and Cable)	2sets	4sets	56sets
Touch Screen Drivers Capacity	50pcs	100pcs	1400pcs
Touch Screen Cables Capacity	500pcs	1000pcs	14000pcs
Driver Cables Capacity	15pcs	30pcs	420pcs

Remark: The above packing information is just for your reference, and we will choice the suitable outer carton for you on your quality ordered.

5. The pictures of the Product.

GD567M03-GTI050TN22 TFT LCD module:

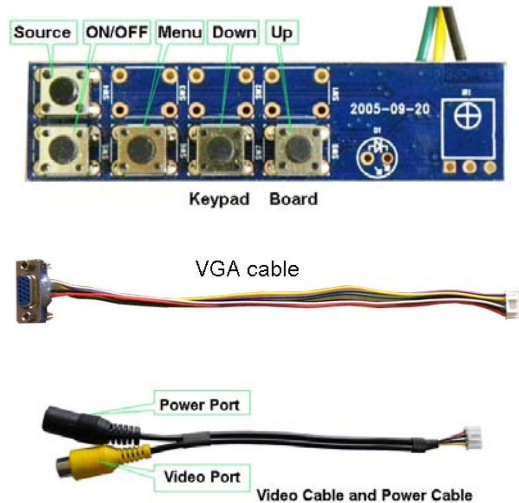
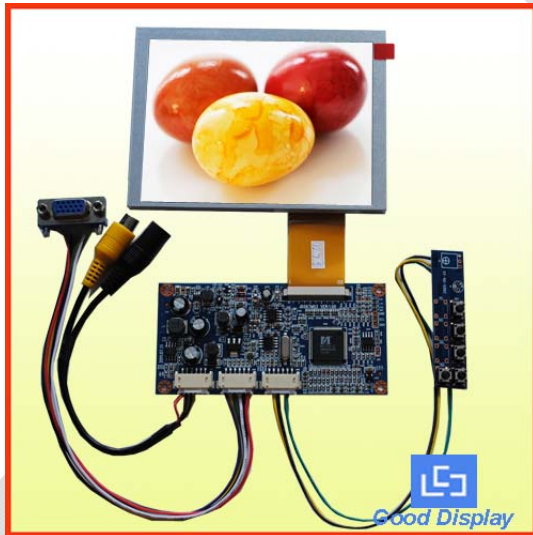

 Good Display	LCD MODULE SPECIFICATIONS	SPEC NO	
	GD567M03-GTI050TN22	REV NO	1.0

The accessory kit (Option):



5.0inch Touch Panel and USB Driver board

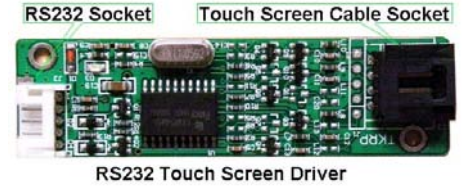

USB cable



RS232 cable



Touch screen Cable

6. Setting the TFT LCD module.

6.1 Key operation, the keypad includes **<Source>**, **< ON/OFF>**, **< Menu>**, **< Down>**, **<Up>**

The description of each key:

< Source>: Press the **<Source>** key to switch the input signal between Video and VGA.

< ON/OFF>: Press the **<ON/OFF>** key on the keypad to turn the backlight ON or OFF. But this is not shutting off the power supply from AC/DC adapter, this only let the module into standby (power saving) status. If you want to shut off the power supply entirely, please pull the DC plug of the AC/DC adapter out from the DC input connector of the module.

<Menu>: Press the **<Menu>** key to pop the OSD menu on no menu status, or exit present menu level to its father menu level. The **<Menu>** key is confirm key also, it confirms your operation.

<Down>: Press the **<Down>** key to move the cursor (highlight bar) from "Down" to "up" on the OSD menu, or reduce the parameters value from "large" to "small". These parameters are such as Brightness, Contrast, Volume, etc.. In addition, it is a shortcut key to decrease the volume value at no menu status.

<Up>: Press the **<Up>** button to move the cursor(highlight bar) from "up" to "Down" on the OSD menu, or increase the parameters value from "small" to "large". These parameters are such as Brightness, Contrast, Volume, etc. In addition, it is a shortcut key to increase the volume value at no menu status.

6.2 OSD menu introduction (On Screen Display)

Press the **<Source>** key to switch the input signal between Video and VGA.

6.2.1 While the Source is Video Signal, press the <Menu> button, pop the top main menu.

Main OSD menu contains the following submenu as below: BRIGHT, CONTRAST, NORMAL, COLOR, EXIT.



 Good Display	LCD MODULE SPECIFICATIONS	SPEC NO	
	GD567M03-GTI050TN22	REV NO	1.0

BRIGHT: When you press the **<Menu>** button move the cursor to the BRIGHT bar on the OSD menu, you can press **<Down>** button or **<Up>** button to adjust the image brightness value.

CONTRAST: When you press the **<Menu>** button move the cursor to the CONTRAST bar on the OSD menu, you can press **<Down>** button or **<Up>** button to adjust the image contrast value.

NORMAL: When you press the **<Menu>** button move the cursor to the NORMAL bar on the OSD menu, you can press **<Down>** button or **<Up>** button to reverse the image, and the item "NORMAL" on the OSD menu will be changed to be "DOWN" correspondingly.

COLOR: When you press the **<Menu>** button move the cursor to the COLOR bar on the OSD menu, you can press **<Down>** button or **<Up>** button to adjust the image color value.

EXIT: When you press the **<Menu>** button move the cursor to the EXIT bar on the OSD menu, then press **<Down>** or **<Up>** button to confirm the EXIT operation, it will exit the present level menu to its father level menu.

6.2.2 While the Source is VGA Signal, press the **<Menu>** button, pop the top main menu.

Main OSD menu contains the following submenu as below: BRIGHT, CONTRAST, NORMAL, EXIT, HPOSITION, VPOSITION, AUTO



BRIGHT: When you press the **<Menu>** button move the cursor to the BRIGHT bar on the OSD menu, you can press **<Down>** button or **<Up>** button to adjust the image brightness value.

CONTRAST: When you press the **<Menu>** button move the cursor to the CONTRAST bar on the OSD menu, you can press **<Down>** button or **<Up>** button to adjust the image contrast value.

NORMAL: When you press the **<Menu>** button move the cursor to the NORMAL bar on the OSD menu, you can press **<Down>** button or **<Up>** button to reverse the image, and the item "NORMAL" on the OSD menu will be changed to be "DOWN" correspondingly.

EXIT: When you press the **<Menu>** button move the cursor to the EXIT bar on the OSD menu, you can press **<Down>** or **<Up>** button to confirm the EXIT operation, and it will exit the present level menu to its father level menu.

HPOSITION: When you press the **<Menu>** button move the cursor to the HPOSITION bar on the OSD menu, you can press **<Down>** or **<Up>** button to adjust the Horizontal image position on the LCD screen.

VPOSITION: When you press the **<Menu>** button move the cursor to the VPOSITION bar on the OSD menu, you can press **<Down>** or **<Up>** button to adjust the Vertical image position on the LCD screen.

AUTO: When you press the **<Menu>** button move the cursor to the AUTO bar on the OSD menu, you can press **<Down>** or **<Up>** button to do a quick auto config for image on no OSD menu status, it adjust phase, clock and image horizontal and vertical position.

 Good Display	LCD MODULE SPECIFICATIONS	SPEC NO	
	GD567M03-GTI050TN22	REV NO	1.0

7. Connection Diagram

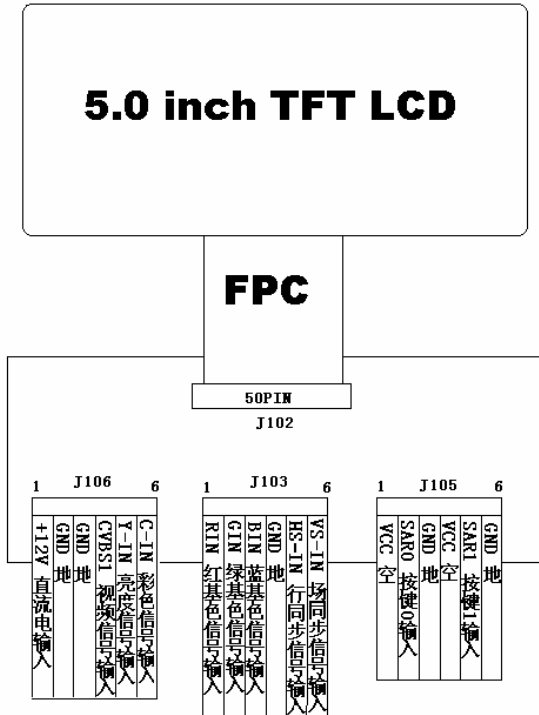

8. The interface definition of the A/D board

8.1 A/D board:JD567M03 Diagram

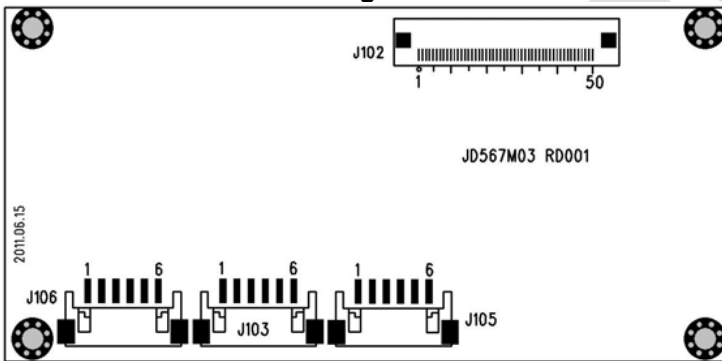

8.2 J106 interface definition:

PIN No.	Symbol	I/O	Description
1	+12V	I	DC power supply input
2	GND	-	Ground
3	GND	-	Ground
4	Video	I	Video signal input
5	Y-IN	I	Brightness signal input
6	C-IN	I	Color signal input

8.3 J103 interface definition:

PIN No.	Symbol	I/O	Description
1	R-IN	I	VGA Red input
2	G-IN	I	VGA Green input
3	B-IN	I	VGA Blue input
4	GND	-	Ground
5	HS-IN	I	VGA Horizontal signal input
6	VS-IN	I	VGA Vertical signal input



Good Display

LCD MODULE SPECIFICATIONS

SPEC NO

GD567M03-GTI050TN22

REV NO

1.0

8.4 J105 interface definition:

PIN No.	Symbol	I/O	Description
1	VCC	-	No Connection
2	SAR0	I	Keypad 0 input
3	GND	-	Ground
4	VCC	-	No Connection
5	SAR1	I	Keypad 1 input
6	GND	-	Ground

8.5 Keypad diagram:

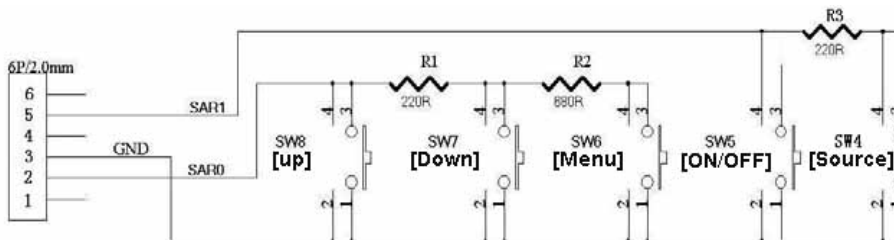
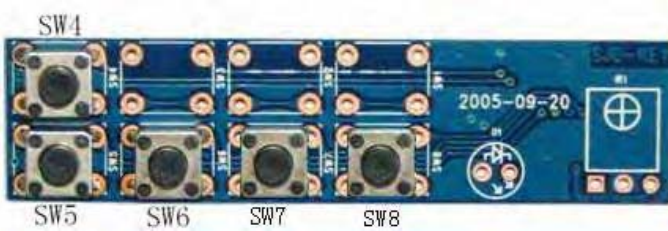

9. Support Display Resolution Mode:

VGA

640 x 480 -- 60 Hz
 640 x 480 -- 72 Hz
 640 x 480 -- 75 Hz

SVGA

800 x 600 -- 56 Hz
 800 x 600 -- 60 Hz
 800 x 600 -- 72 Hz
 800 x 600 -- 75 Hz

XGA

1024 x 768 -- 60 Hz

※ Recommend customer to use VGA (640x480) resolution.



Good Display

LCD MODULE SPECIFICATIONS

GD567M03-GTI050TN22

SPEC NO

REV NO

1.0

10. TFT LCD Panel Mechanical Drawing

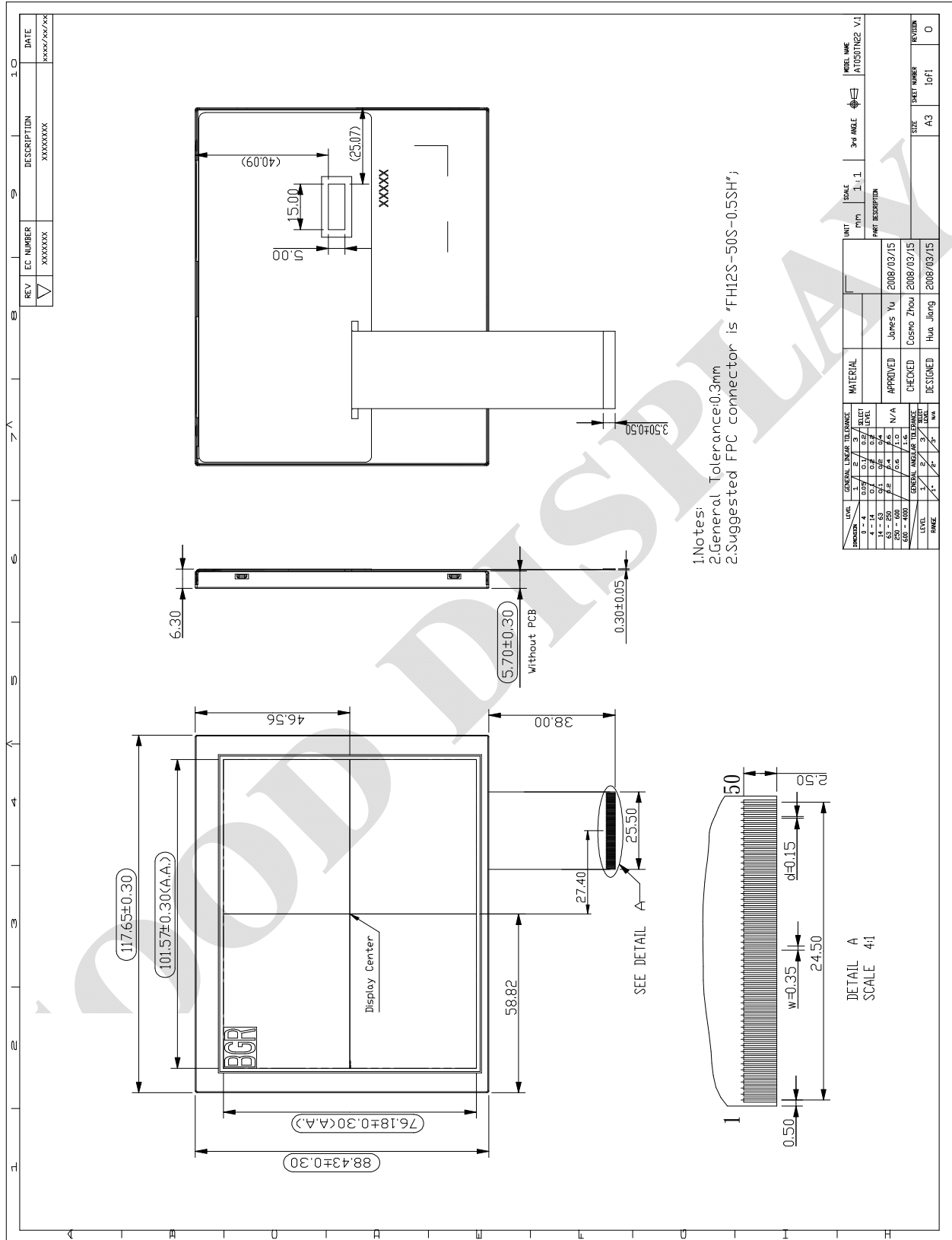



Good Display

LCD MODULE SPECIFICATIONS

SPEC NO

GD567M03-GTI050TN22

REV NO

1.0

11. A/D Board: JDM567M03 Mechanical Drawing

A/D board dimension: 102.0 (W)x50.0 (H) x7.9(D) mm

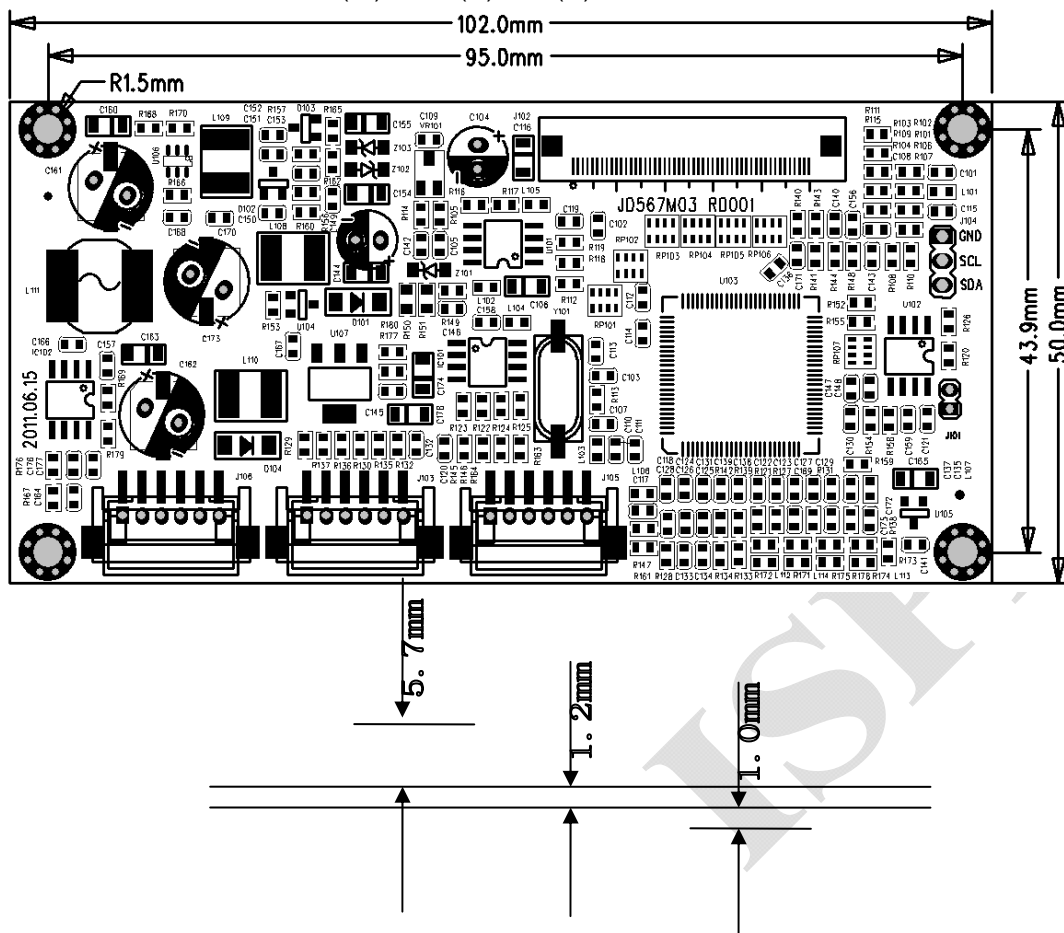

12. Touch Screen: GDT4W05001 Mechanical Drawing (Option)

PIN	OUT
1	X1
2	Y1
3	X2
4	Y2

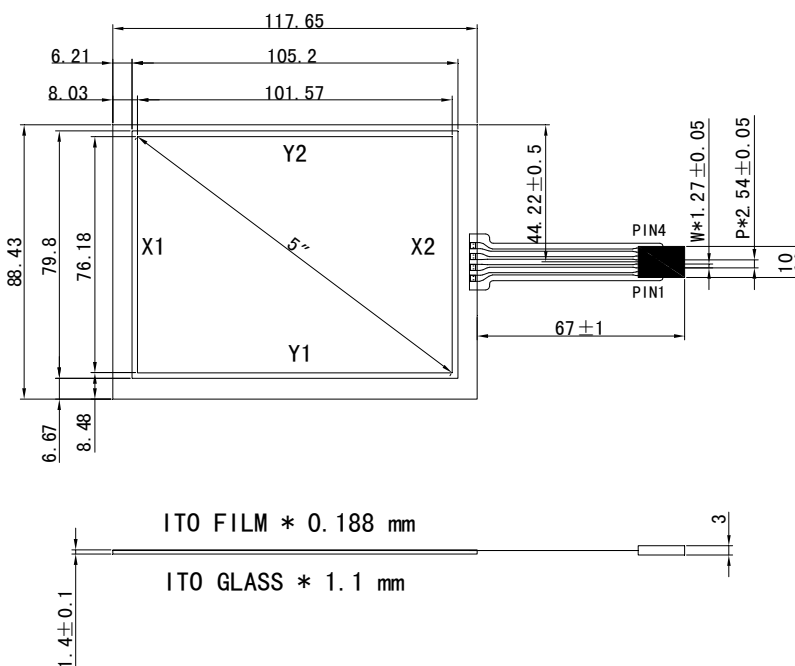
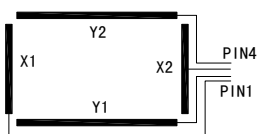

 Good Display	LCD MODULE SPECIFICATIONS	SPEC NO	
	GD567M03-GTI050TN22	REV NO	1.0

13. Touch screen driver board Mechanical Drawing (Option)

For USB interface

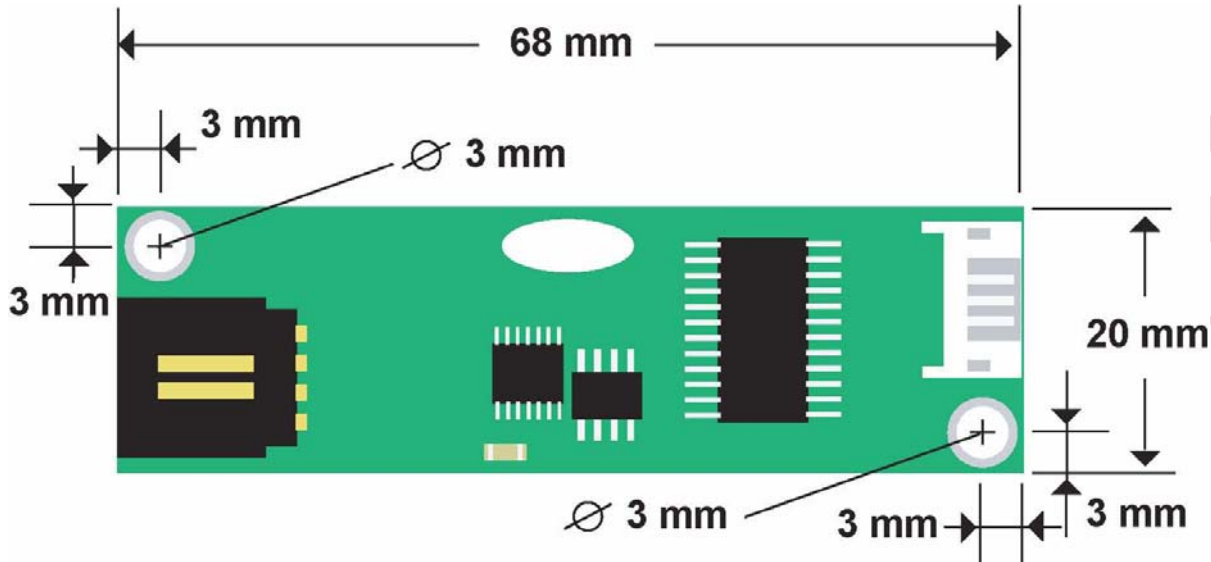

For RS232 interface

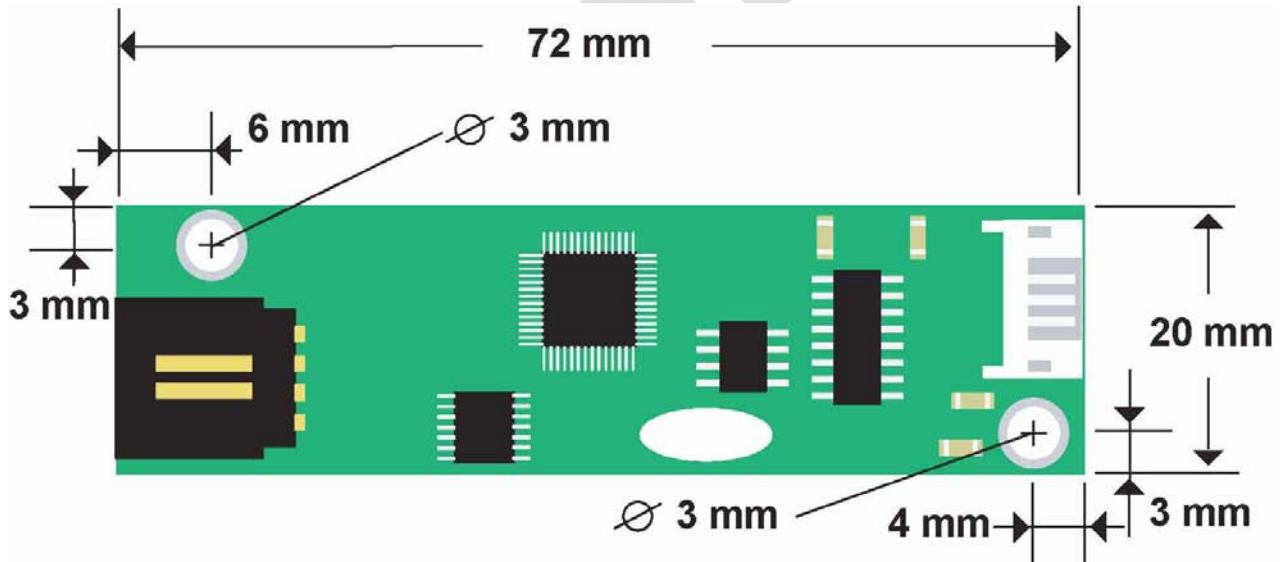

 Good Display	LCD MODULE SPECIFICATIONS	SPEC NO	
	GD567M03-GTI050TN22	REV NO	1.0

14. Product Label



Label Dimension : 48.0X12.0mm

XXXXXX / XXXXXX

Production Date (Y/M/D)

Delivery Date (Y/M/D)

15. Precaution

For the sake of normal usage of this product, preventing incident from the electric shock or fire etc., please follow the precaution below instructions:

1. Before operating this appliance, read these instructions, keep these instructions, heed all warnings, and follow these instructions.
2. The DC (Direct current) supply of appliance is from the indicated AC (Alternating Current)/DC adapter. The AC voltage and AC frequencies C should be in of accord with the description of its on Metal card, the power adapter should be away from the hotness, being put in the well ventilated place.
3. AC power electric outlet and the AC power line of the AC/DC adaptor must be noticed to connect a ground well, and have an enough power supply if needed.
4. Input electric voltage of DC supply of our board is 12V, the error margin is not over and above +/- 3V/, The value of the electric current changes for the different LCD and that whether to have audio amplifier or not etc. Pay attention to connect well between 12V DC power electric outlet and the power electric outlets of the board.
5. Do not place the board inside of the Hull or Box that do not transmit heats, with the environment the airiness spreads well, Do not let the sunshine contact the board or other heat sources close to it, The heat sources, such as radiators, stoves, or their apparatus that produce heat.
6. Pay attention to prevent it from contacting with wetness or the dust, in order to protect the electric circuit from decaying.
7. While assembling, pay attention to reserve the certain space to keep the air spreads well, while it can prevent the conductor (for the fixed sheet iron of the of the controller board and the inverter) from contacting with the units of electricity board, from happening the short circuit with the board.(knothole install position bore etc. excepted) .
8. While assembling, pay attention to make sure that the controller board is prevented from not being curved because of the additional pressure.
9. While assembling, notice that the controller board is in right connection with inverter, LCD, OSD keypad, choosing the right LCD work electric voltage(over low the display will not right, LCD may be burnt under over the high work voltage), The power is ON after all checking is well.
10. The circuit signal on the Keypad board, the infrared acceptor and the inverter must pass directly the electric cable to connect to the IC on the board, the attention is that avoiding short circuit and the damages from the static electricity on the hand ESD.
11. All connectors of output or input should be operated under the situation of cutting the power (pull out to put to deal with contact).
12. This product is applicable to common business usage and domestic usage, if it is applied into the environment with high temperature (such as in outdoor), high humidity, the strong vibration (carried in car), strong electromagnetism radiation, please contact our sales personnel.
13. Please pull out the power supply if you do not use it in a long time.

 Good Display	LCD MODULE SPECIFICATIONS	SPEC NO	
	GD567M03-GTI050TN22	REV NO	1.0

16. Trouble Shooting

If experiencing trouble with the module, or it fails to operate correctly, please refer to the following instructions before returning to us for repairs.

Condition	Check Point
1. The picture does not appear	Check to see that all the I/O and power cables is firmly seated in the socket. Check if the brightness control is at the appropriate position, not at the minimum.
2. The screen is not synchronized	Check if the I/O signal cable is firmly seated in the socket. Check if the output level matches the input level. Make sure the signal timings of the computer system are within the specification of the module.
3. The position of the screen is not in the center	Adjust the H-position, and V-position, or perform the auto adjustment.
4. The screen is too bright (too dark).	Check if the brightness or contrast control is at the appropriate position, not at the Maximum (Minimum).
5. The Screen is shaking or waving	Press the Auto adjustment control to adjust. Moving all objects which emit a magnetic field such as motor or transformer, away from the module. Check if the specific voltage is applied. Check if the signal timing of the computer system is within the specification of module.

If you are unable to correct the fault by using this chart, stop using your module and contact us.