



**AIR-HYDRAULIC
SLIDING JACKBEAM
6000 lbs.**

INSTALLATION AND OPERATION MANUAL

**SAVE ALL INSTRUCTIONS
READ ALL INSTRUCTIONS**



65000 Millcreek Drive, Mississauga, Ontario, L5N 2W6
Tel: (905) 826-8600
Fax: (905) 826-7800

JULY 2005 6-2331

JACKING BEAM INSTALLATION AND OPERATION MANUAL

6000 LBS. JACKING BEAM OPERATION

Positioning of Vehicle on Jacking Beam

1. The vehicle must be positioned correctly on the lift prior to raising the vehicle with the jacking beam.

LIFTING AN IMPROPERLY POSITIONED VEHICLE WITH THE JACK BEAM INCREASES THE POSSIBILITY OF ONE DECK LEADING OR LAGGING THE OTHER DECK.

NOTE: USE ONLY THE SAME LIFTING PADS ON BOTH ARMS.

2. Move the jacking beam to the desired pickup area and connect the air line (if not permanently connected).

NOTE: EASE OF POSITIONING WHILE JACKING BEAM IS NOT UNDER LOAD IS DUE TO THE TRACK ROLLER ASSEMBLIES. THE ROLLER ASSEMBLIES ARE SPRING LOADED TO CARRY THE WEIGHT OF THE JACK ONLY. WHEN THE JACKING BEAM IS UNDER LOAD THE JACK RESTS ON ITS STRUCTURE AND CANNOT BE MOVED.

3. With the jacking beam positioned at the desired working location, select the proper lifting pads. Insert the lifting pads into the arms.

NOTE: LIFT VEHICLE AT MANUFACTURER'S RECOMMENDED PICKUP POINTS ONLY.

4. With the vehicle's center of gravity equally spaced between the decks, the jacking beam can be used to lift the vehicle. Select lifting points that are the same distance from the centerline of the vehicle, i.e. position the jack beam pads so that they make contact at the same point on each side of the vehicle.

Raising the Jack Beam

1. Press the up button and hold until jacking beam is at full working height and the automatic safety is in place. Lower the jack beam onto the safety (Note: there are two safety stops to allow multiple working heights).

NOTE: NEVER WORK ON A VEHICLE UNLESS THE SAFETY LOCK IS ENGAGED AND THE JACKING BEAM CANNOT BE LOWERED.

Lowering the Jack Beam

1. To lower the jacking beam, first raise the jack up off the mechanical safety lock and release the safety lock using the safety release lever.

NOTE: THE SAFETY LEVER MUST BE MANUALLY HELD IN THE RELEASED POSITION.

2. Press the control handle to release pressure allowing the jacking beam to lower to its full down position.
3. Never operate a jacking beam that is not in proper working order or in a manner not recommended by the vehicle or jacking beam manufacturer.

ALWAYS ENSURE THAT THE MECHANICAL SAFETY IS ENGAGED WHENEVER A VEHICLE IS SUPPORTED BY THE JACKING BEAM.

Recommended Maintenance

1. Inspect the jacking beam on a daily basis to ensure the jacking beam is in proper working condition.
2. Make certain that the automatic safety drops into place when the jacking beam is raised and that it will release when held in the down position during lowering.
3. Check the hydraulic fluid when jacking beam is in the lowered position by removing the filler breather cap.
4. Keep the air source clean and make certain that an air filter is used to keep dirt out of the air motor.
5. Keep the entire jacking beam as clean as possible at all times.
6. To maintain a clean shop air supply, (oil, lube, filter and regulator) should always be in good working order in conjunction with the use of an oiler/separator.

JACKING BEAM ASSEMBLY 6000 LBS.

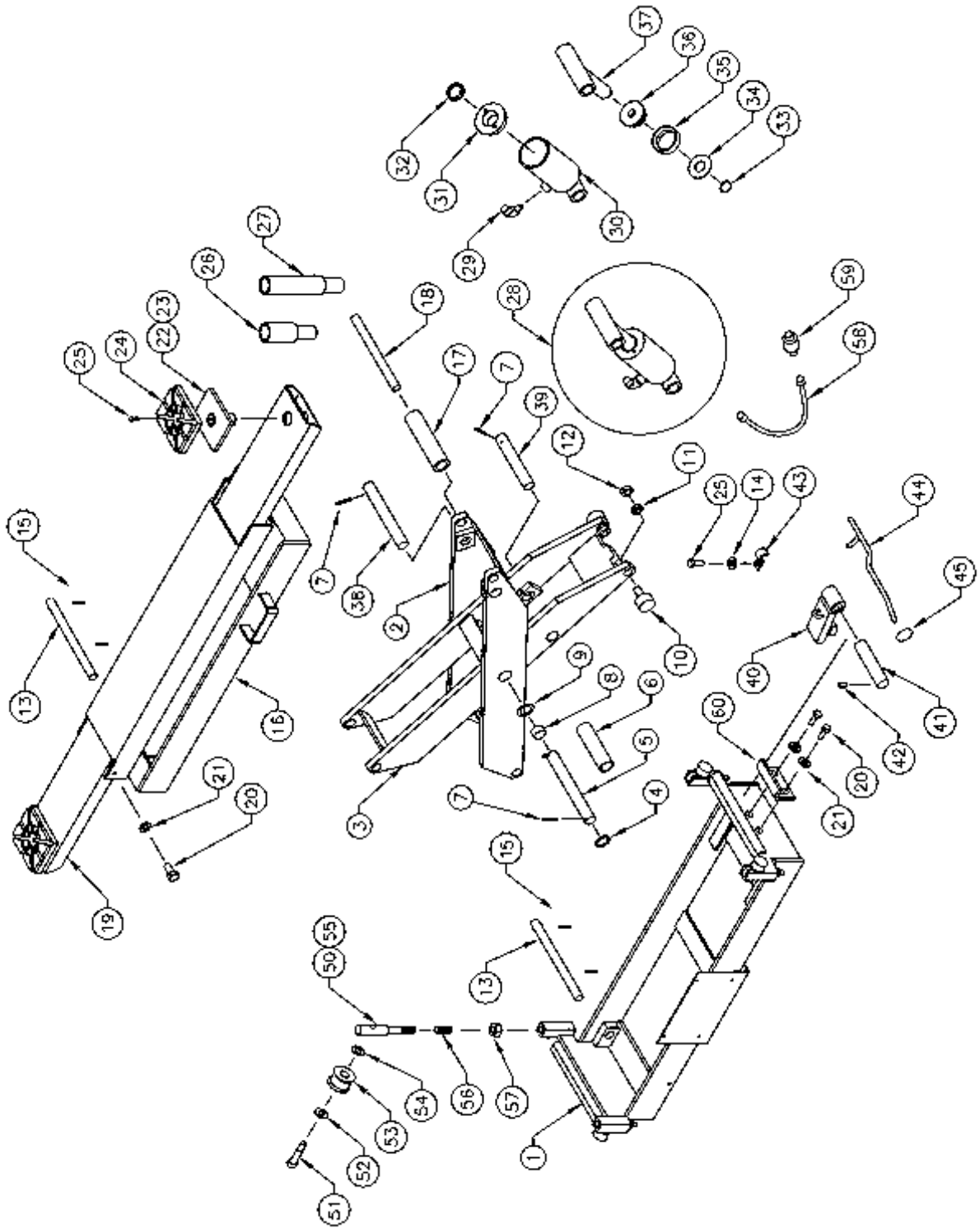

ITEM	QTY.	DESCRIPTION	PART #
1	1	BASE FRAME WELDMENT	3-0723
2	1	OUTER SCISSOR WELDMENT	3-0824
3	1	INNER SCISSOR WELDMENT	3-0825
4	1	WASHER, 1 1/32" ID	6-0807
5	1	SCISSOR CENTER SHAFT	1-2270
6	1	CENTER PIPE SPACER	1-0575
7	4	SPRING PI, 3/16" X 2" LG	6-0146
8	4	BUSHING	6-2320
9	2	THRUST WASHER	6-0328
10	2	CAM FOLLOWER	1-1269
11	2	SPACER	1-0228
12	2	JAM NUT, 5/8"-NF	6-0040
13	2	SCISSOR PIN	1-1999
14	2	LOCKWASHER, 1/4" ID	6-0056
15	4	SET SCREW 1/4"-20 X 1 1/2	6-0438
16	1	TOP WELDMENT	3-0725
17	1	ROLLER ASSEMBLY	1-1997
18	1	ROLLER SHAFT	1-1998
19	2	LIFTING ARM WELDMENT	2-1572
20	6	HEX HD BOLT, 3/8"-NC X 3/4" LG	6-0030
21	6	LOCKWASHER, 3/8" ID	6-0058
22	2	STACK PAD ASSEMBLY COMPLETE	1-2634
23	2	STACK PAD WELDMENT	2-1993
24	2	RUBBER PAD	3-0872
25	4	ALLEN HD. FLAT SCREW, 1/4"-20 X 3/4" LG.	6-1086
26	2	STACK PAD ADAPTER, 3"	1-1993
27	2	STACK PAD ADAPTER, 6"	2-1580
28	1	CYLINDER ASSEMBLY COMPLETE	3-0474
29	1	VELOCITY FUSE	1-1726
30	1	CYLINDER TUBE WELDMENT	2-0911
31	1	GLAND	1-1152
32	1	ROD WIPER	6-0653
33	1	SNAP RING	6-0581*
34	1	KEEPER WASHER	1-1148*
35	1	SEAL AND WEAR RING	6-2915*
36	1	PISTON	1-1150
37	1	PISTON ROD WELDMENT	2-0913
38	1	OUTSIDE CYLINDER SHAFT	1-1158
39	1	INSIDE CYLINDER SHAFT	1-1163
40	1	SAFETY STOP WELDMENT	2-1577
41	1	SAFETY PIN	1-0561
42	2	SET SCREW, 1/4"-NC X 3/4" LG	6-0438
43	2	CLIP	1-0432
44	1	SAFETY LEVER ARM	1-2271
45	1	KNOB	6-0251

ITEM	QTY.	DESCRIPTION	PART #
50	4	ROLLER ASSEMBLY COMPLETE	2-0259
51	4	SHOULDER BOLT, 3/8"-NC X 1" LG	6-0206
52	4	THRUST WASHER, 3/8" ID	6-0223
53	4	TRACK ROLLER ASSEMBLY	2-0098
54	4	THRUST WASHER, 3/8" ID	6-0224
55	4	SPRING STEM	1-0204
56	4	SPRING	6-0081
57	4	NYLON LOCKNUT, 3/8"-NC	6-0042
58	1	HYDRAULIC HOSE	1-0765
59	1	ADAPTER, 3/8"NPT-M x 3/8"JIC-M	6-0011
60	2	KEEPER BRACKET	1-2376
NOTE	1	AIR/HYDRAULIC PUMP COMPLETE	6-1428
NOTE	1	SCISSOR ASSEMBLY COMPLETE	3-0826
	NOTE:	PART NUMBERS MARKED WITH AN ASTERIX (*) ARE CONTAINED IN REPAIR KIT NUMBER 0-1287	

- **THE FOLLOWING PARTS ARE FOR (-L) MODELS, REAR, LEFT SIDE AIR CONNECTION**

QTY.	DESCRIPTION	PART #
1	STREET TEE	6-0015
2	1/4"NPT TO 3/8" PLOYTUBE	6-0710
1	1/2" TUBE CLAMP	6-0536
1	90° ELBOW, 1/4"NPT F TO 1/4" NPT F	6-0967

AIR / HYDRAULIC PUMP PARTS LIST

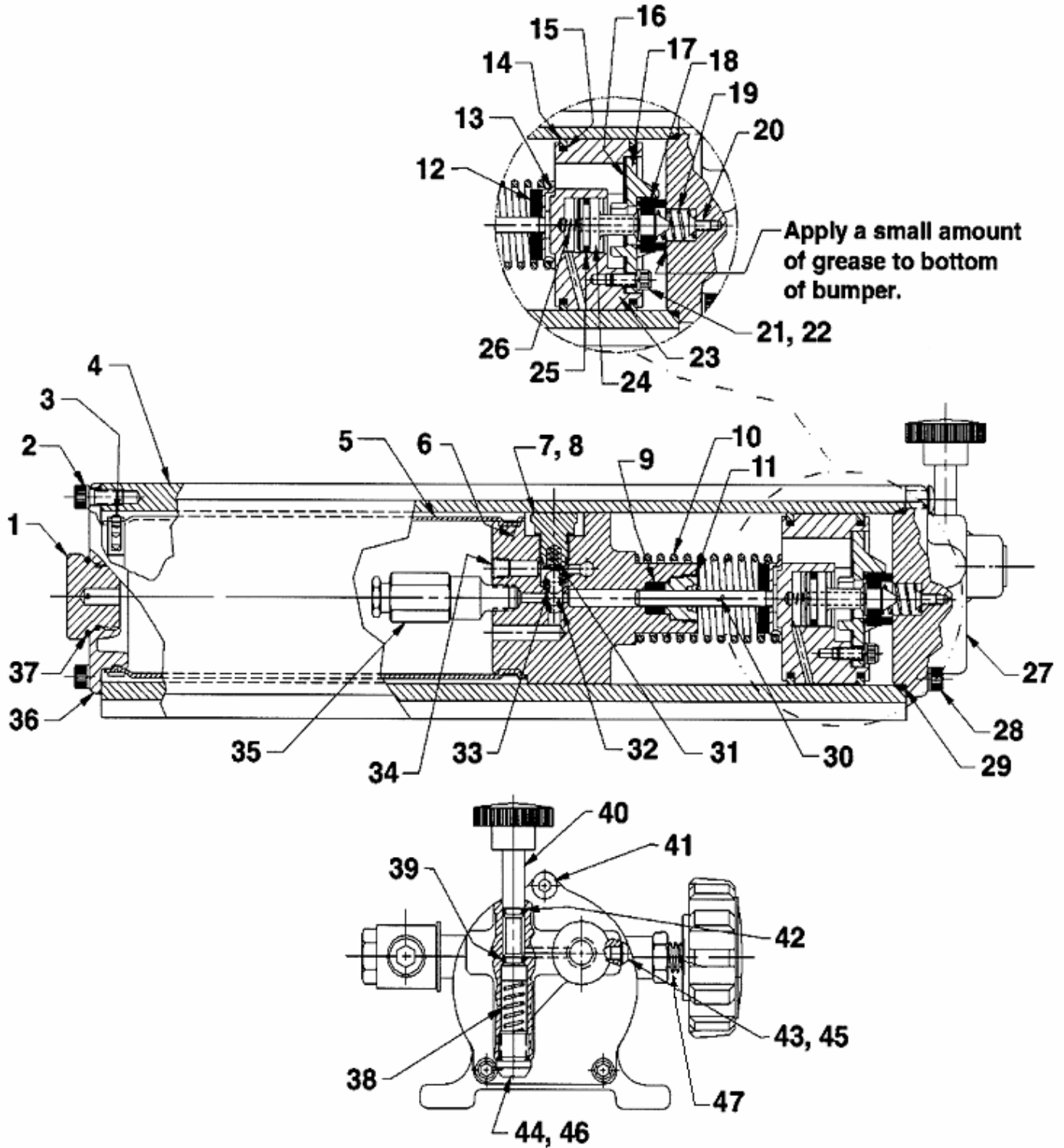

ITEM	QTY.	DESCRIPTION	PART #
1	1	FILLER PLUG	6-2332
2	3	SCREW, ¼"-NC X ½"	6-2333
3	2	CLAMP	6-2334*
4	1	PUMP HOUSING	6-2335
5	0.5	BLADDER	6-2336*
6	1	PUMP BODY	6-2337
7	1	VALVE SCREW	6-2338
8	1	COPPER WASHER	6-2339*
9	1	U-CUP	6-2340*
10	1	COMPRESSION SPRING	6-2341
11	1	RETAINER	6-2342*
12	1	BUMPER	6-2343*
13	1	SPRING GUIDE	6-2344
14	2	PISTON RING	6-2345*
15	2	O-RING	6-2346*
16	1	GASKET	6-2347*
17	1	PISTON END CASTING	6-2348
18	1	PISTON POPPET	6-2349*
19	1	COMPRESSION SPRING	6-2350*
20	1	FLAT HD SCREW, 8-32 X 3/8"	6-2351
21	3	SOC. HD SCREW, 10-32 X ½"	6-2352
22	3	LOCKWASHER	6-2353*
23	1	PISTON BODY	6-2354
24	1	EXHAUST VALVE SYSTEM	6-2355
25	1	O-RING	6-2356*
26	1	COMPRESSION SPRING	6-2357*
27	1	REAR HEAD	6-2358
28	2	SCREW	6-2359
29	1	O-RING	6-2360*
30	1	PISTON	6-2361
31	1	COMPRESSION SPRING	6-2362*
32	1	STEEL BALL, ¼"	6-2363*
33	1	STEEL BALL, 3/8"	6-2364*
34	1	PLUG FITTING	6-2365
35	1	RELIEF VALVE	6-2366
36	1	END FILLER CAP	6-2367
37	1	O-RING	6-2368*
38	1	COMPRESSION SPRING	6-2369
39	1	O-RING	6-2370*
40	1	VALVE STEM	6-2371
41	1	SCREW, ¼"-NC X ¾"	6-2372
42	1	O-RING	6-2373*
43	1	BUTTON HD SCREW, 10-24 X ½"	6-2374
44	1	SCREW, ½"-NC X ½"	6-2375
45	1	SPECIAL WASHER	6-2376
46	1	O-RING	6-2377
47	1	RELEASE PIN	6-2969
	NOTE:	PART NUMBERS MARKED WITH AN ASTERIX (*) ARE CONTAINED IN REPAIR KIT NUMBER 6-2404	

AIR/HYDRAULIC PUMP PARTS LIST

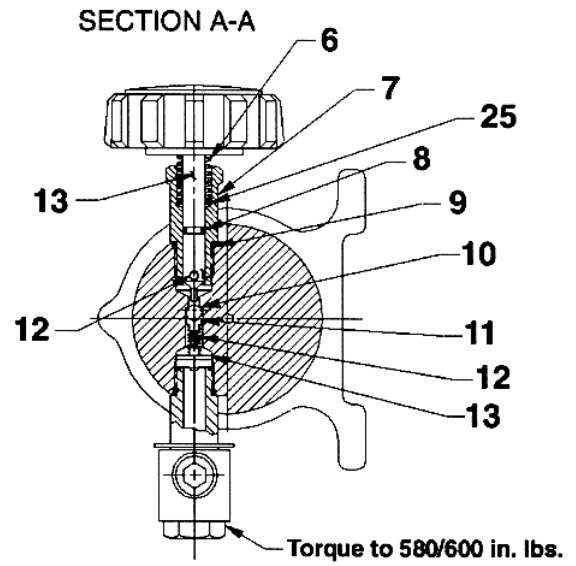
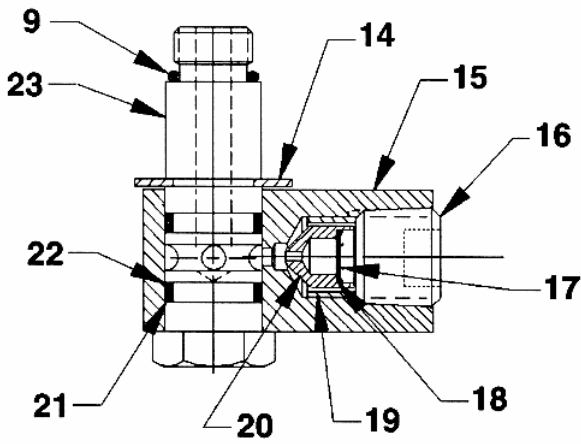
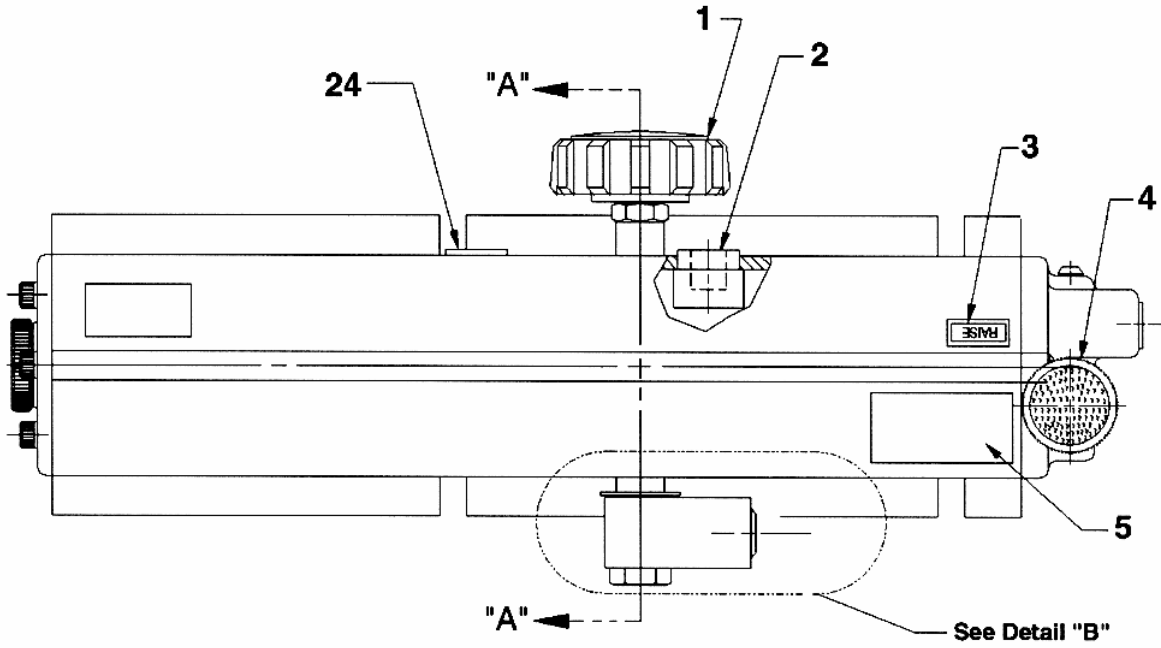

ITEM	QTY.	DESCRIPTION	PART #
1	1	KNOB	6-2378
2	2	MUFFLER	6-2379*
3	1	DECAL	6-2380
4	1	KNOB	6-2381
5	1	WARNING DECAL	6-2382
6	1	COMPRESSION SPRING	6-2383
7	1	PIVOT CAM	6-2384
8	1	O-RING	6-2385*
9	2	O-RING	6-2386*
10	1	STEEL BALL, 7/32"	6-2387*
11	1	BALL GUIDE	6-2388
12	1	COMPRESSION SPRING	6-2389*
13	1	BUSHING	6-2390
14	1	RETAINING RING	6-2391
15	1	SWIVEL BLOCK	6-2392
16	1	PLUG FITTING	6-2393
17	1	FILTER DISC	6-2394*
18	1	RETAINING RING	6-2395*
19	1	POPPET RETAINER	6-2396
20	1	POPPET	6-2397
21	2	BACKUP WASHER	6-2398*
22	2	O-RING	6-2399*
23	1	SWIVEL FITTING	6-2400
24	1	DECAL	6-2401
25	1	WASHER	6-2402
	NOTE:	PART NUMBERS MARKED WITH AN ASTERIX (*) ARE CONTAINED IN REPAIR KIT NUMBER 6-2404	

