



Made in USA

Ideal Chicken Broilers offer heavy duty components to assure high performance and durability on a fast cooking environment. Our Chicken Broilers are designed and constructed to fulfill the need of an easy to clean Broiler and to withstand the rough daily activities. The 36" depth cooking surface is complemented with a Stainless Steel round rod non-stick welded top grate. The complete chassis is made out of heavy duty welded material and heavy gage Stainless Steel exteriors. An optional large receptacle stand holds the grease and can be supplemented with casters for mobility.

STANDARD FEATURES

- Heavy gage Stainless Steel exteriors.
- 36" depth large broiling surface.
- Heavy duty stainless steel "I" type burners rated at 40,000 BTU/hr for model depth 27" and 50,000 for 36" depth.
- Adjustable gas valve with continuous pilot for instant ignition.
- Separate gas control for each burner.
- Welded Stainless Steel non-stick round rod top grate.
- 27" depth broilers can hold 2 rows of chickens, while 36" broiler depth can hold up to 3 rows.
- Available in 36", 48", and 60" widths.
- Heavy gage stainless steel welded stand with drain and casters are included in the unit.
- One year parts and labor warranty.
- Complies with "ANS Z83.11a-2004 / CSA 1.8-2004 Food Service Equipment".

Gas: 3/4" NPT rear gas connection, specify type of gas and altitude if over 2,000 feet.
Pressure: 5" W.C. - Natural Gas
 10" W.C. - Propane Gas
Note: Install the supplied gas pressure regulator at the inlet of the gas line.



Model: IDCKB-36 Shown

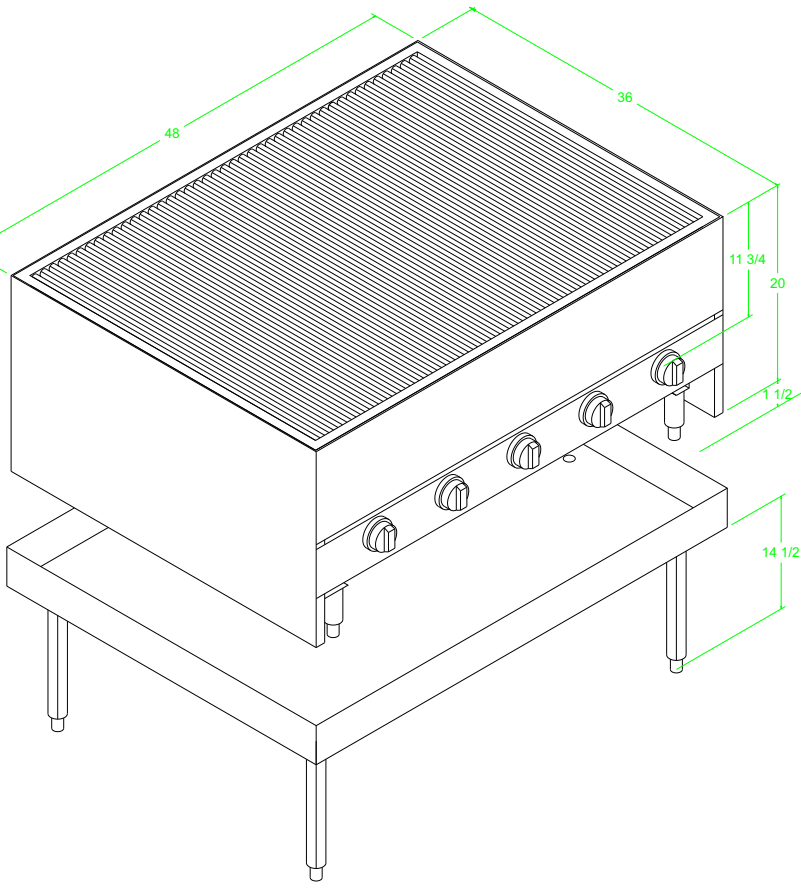

Model	Dimensions	Weight	Total BTU's/hr	Price List
IDCKB-36-27	36"W x 27"D x 20"H	245 Lbs.	160,000	\$ 3,995.00
IDCKB-48-27	48"W x 27"D x 20"H	330 Lbs.	200,000	\$ 5,840.00
IDCKB-48-36	48"W x 36"D x 20"H	390 Lbs.	250,000	\$ 6,770.00
IDCKB-60-27	60"W x 27"D x 20"H	420 Lbs.	240,000	\$ 7,385.00
IDCKB-60-48	60"W x 48"D x 20"H	490 Lbs.	300,000	\$ 8,303.00

IDCKB - CHICKEN BROILER Series