

## SILENTPIN™ System Idler

### TECHNICAL DATA SHEET

**RollEase® SILENTPIN™ Idler**  
**Part Number: MSPE5BK**

The SILENTPIN™ Idler fastens to the SILENTPIN™ Idler Bracket to securely capture and lock the 10mm idler shaft to prevent unintentional separation. The method of retention of the idler pin also prevents the shaft from spinning in the bracket. Instead, the rotation of the shade is accomplished by the housing and internal bronze bushing rotating around the steel shaft. This system is exceptionally safe and quiet.

**Qualified:** The SILENTPIN™ System with the SILENTPIN™ Adapter Sets and RollEase® Tube is life tested to meet RollEase® qualification standards.

**Max Load:** 254 lbs (115 kgs)

**Mounting:** Using the SILENTPIN™ Idler, Bracket Set, Adapter Set and RollEase® Tube produces a reliable, safe and remarkably quiet motorized shade. On applications over 10' wide it is recommended to fasten the yellow drive wheel of the idler into the tube.

**Adjustability:** The SILENTPIN™ Idler shaft can travel longitudinally 1.375" (35mm) allowing for some flexibility during installation. The more compressed the shaft, the minimal the light gap.

**Total Tube Deductions:** Minimum 1.5" (0.75" motor and Idler equal on both sides) Maximum 2.5" (0.75" motor and 1.75" Idler).

**Achievable Minimum Light Gap:** 0.75" minimum per side.

#### RollEase® SILENTPIN™ Adapter Sets:

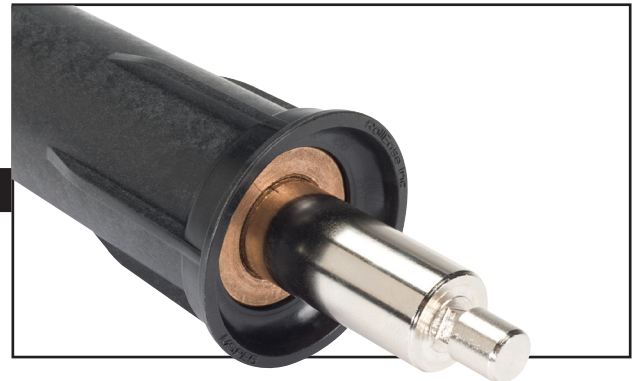
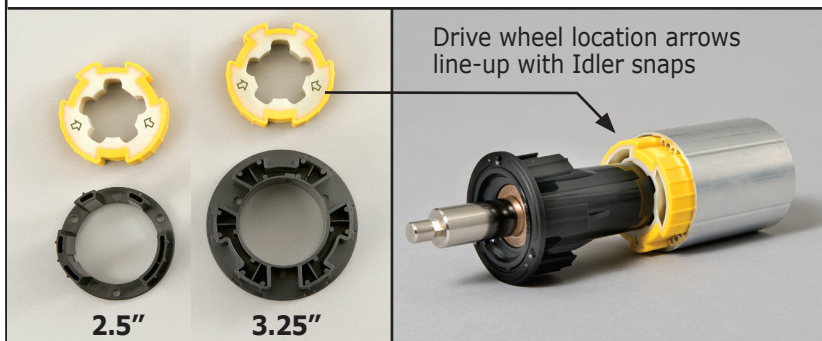

#### SILENTPIN™ Idler MSPE5BK

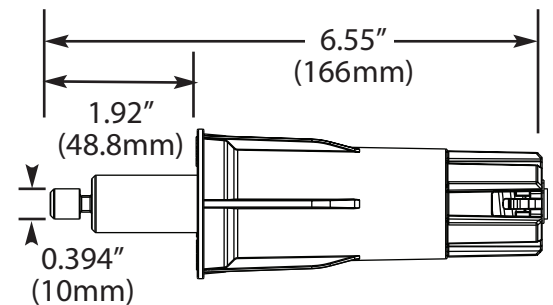

#### RollEase® SILENTPIN™ Idler Fits These Tube Sizes:

**2" Smooth Wall Tube: RTEASW5T14**  
 Tube must be notched. No adapters necessary.

**2.5" (63mm) Profile Tube: RTEA6T16**  
 Use Motor Adapter Set: **RTA6U50BK**

**3.25" (83mm) Profile Tube: RTEA7T16**  
 Use Motor Adapter Set: **RTA7U50**

The adapter set consists of a crown, drive and screws custom fit to RollEase® profile tubes. The drives are overmolded with a soft thermoplastic elastomer to dampen noise produced from motor vibration.

#### Taped or Untaped Aluminum Tubes for Motorization

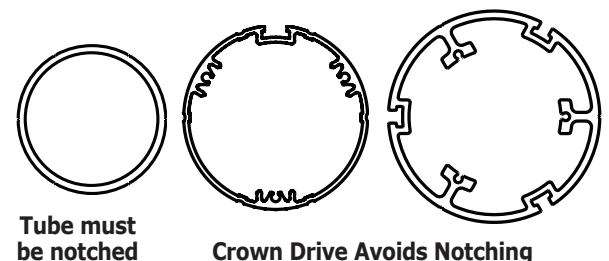

**RollEase Headquarters**  
 200 Harvard Avenue  
 Stamford, CT 06902-6320 USA  
 Office: 203.964.1573 / 800.552.5100  
 Fax: 203.964.0513 Order Fax: 203.358.5865  
[www.rollease.com](http://www.rollease.com)

**RollEase Distribution Center**  
 320 Expo Boulevard  
 Lenoir, NC 28645 USA

**RollEase West**  
 7310 West Roosevelt Street, Suite 26  
 Phoenix, AZ 85043 USA  
 Office: 623.936.5818  
 Order Fax: 623.936.5294