Installation & Operating Manual

Electro Industries' Make-Up Air II

Models EM-MA01 & EM-MA02

Included With This Product

- Permanent washable air filter
- Powered inlet damper
- Temperature sensor
- Chain kit for ceiling installations

Other Requirements

- “Turn-on” device (switch closure) connected to R & W (Class II wiring)
- High voltage wiring
- Fresh air intake wall vent
- Inlet/outlet ductwork

Application

This product aids in preventing building depressurization where there is an exhaust blower/fan, coupled with a tight building envelope.

UL Standard 1995, CSA C22.2 NO.236.11

Drawings: UAW873, XX017

DO NOT DESTROY THIS MANUAL. PLEASE READ CAREFULLY AND KEEP IN A SAFE PLACE FOR FUTURE REFERENCE BY A SERVICE TECHNICIAN.



ELECTRO INDUSTRIES, INC.
2150 West River Street, PO Box 538, Monticello, MN 55362
763.295.4138 • 800.922.4138 • fax 763.295.4434
sales@electromn.com • www.electromn.com

Table of Contents

	<u>Page</u>
Product Description	1
Handling & Storage	1
Placement & Mechanical Information	1
Product Configurator	2
Specification Tables	2
Dimensional Drawings	3
Safety Consideration	4
Installation Requirements	4
Installation Overview	5
Mechanical Installation	6
Electrical Installation	8
Control Wiring	8
High Voltage Hookup	9
Basic Setup	10
Operational Indicators	11
Troubleshooting	12
Routine Maintenance	13
Replacement Parts	13
Drawings	UAW873 XX017

Product Description

This is a self-contained package with a permanent (washable) air filter, electric heating elements, modulating element temperature control, powered damper and fan. This product has been designed specifically for outside air inlet.

All models include WarmFlo electronic outlet temperature sensor and associated control circuitry to modulate the electric elements for a fixed outlet temperature. This means the electric element is only used to “make-up” or heat the outside fresh air to the preset temperature point. There is no overheating or inefficient use of the electric element.

Heating elements are locked out when this unit’s outlet air temperature is greater than the set point dial switch.

Diagrams used throughout the installation manual represent general installation requirements. Due to various model sizes available, actual unit mechanical and wiring requirements will vary dependent upon specific model.

Handling & Storage

Receiving

It is the receiver’s (person and/or company signing off on the receiving Bill of Lading) responsibility to inspect for shipping damage. All shipping claims must be made by the receiver.

Storage

Packed or unpacked, the Make-Up Air unit shall not be exposed to rain, snow, or other adverse environment. This product is designed for in-building storage and installation only.

As much as possible this product must be protected throughout the construction phase to avoid accumulation of dust and moisture on the components and control box. The installing contractor is responsible for maintaining the cleanliness and quality of this unit until installation is complete and approved by the user/end customer.

Placement & Mechanical Information

This product is designed for zero clearance, but use the following mounting and spacing criteria:

1. Unit can be installed vertically or horizontally. When vertical, inlet must face down.
2. Make mounting provisions for a 1” air space at the top.
3. The sides, any location, can be in direct contact with wood framing materials.
4. No materials shall be in contact with the cabinet housing which has a flame point less than wood, 300°F (150°C).
5. Product shall be installed in a conditioned space only.
6. Heating elements are locked out when outlet air temperature is > set point dial switch.

Product Configurator

EM-MA10-240-1-10

Option

A =
X = No Damper

kW

01 = 1 kW
02 = 1.6 kW
03 = 3 kW
05 = 5 kW
06 = 6 kW
10 = 10 kW
15 = 15 kW
20 = 20 kW
14 = 14 kW
22 = 22 kW

Collar Size

06 = 6"
08 = 8"
10 = 10"
14 = 14"

Phase

1 = Single phase
3 = Three phase

Volts

120 = 120-volt
240 = 240-volt
208 = 208-volt (3-phase)

Specification Tables

Temperature Rise & CFM Chart (this model series)

Model →	SINGLE PHASE MODELS	
	MA01	MA02
	CFM	CFM
80° F	39	63
70° F	45	72
60° F	53	84
50° F	63	101
40° F	79	126
30° F	105	168

Specifications

Model	kW	Btu/h	Amps	Internal CB	Motor FLA	Motor HP	Phase	Voltage	CFM		Max Fuse/HACR	Duct Connection	Shipping Weight
									Max	Static			
EM-MA01-120-1-06	1	3,410	8.3	N/A	0.5	1/16	1-50/60	120	150	0.03"	15	6"	31
EM-MA02-120-1-06	1.6	5,460	13.3	N/A	0.5	1/16	1-50/60	120	150	0.03"	20	6"	32
EM-MA05-240-1-08	5	17,070	20.8	N/A	0.4	1/10	1-50/60	240	350	0.03"	30	8"	59
EM-MA10-240-1-10	10	34,150	41.6	N/A	0.8	1/5	1-50/60	240	625	0.03"	60	10"	65
EM-MA15-240-1-14	15	51,220	62.4	60 + 30	1.7	1/3	1-50/60	240	1050	0.25"	90	14"	115
EM-MA20-240-1-14	20	68,300	83.2	60 + 60	2.5	1/2	1-50/60	240	1200	0.25"	120	14"	120
EM-MA03-208-3-08	3	10,240	8.3	N/A	0.4	1/10	3-50/60	208	350	0.03"	15	8"	55
EM-MA06-208-3-08	6	20,480	16.7	N/A	0.4	1/10	3-50/60	208	350	0.03"	25	8"	58
EM-MA14-208-3-14	14.4	49,170	40.0	50	1.7	1/3	3-50/60	208	900	0.25"	50	14"	115
EM-MA22-208-3-14	21.6	73,760	60.0	50 + 30	2.5	1/2	3-50/60	208	1250	0.25"	80	14"	125

Dimensional Drawings

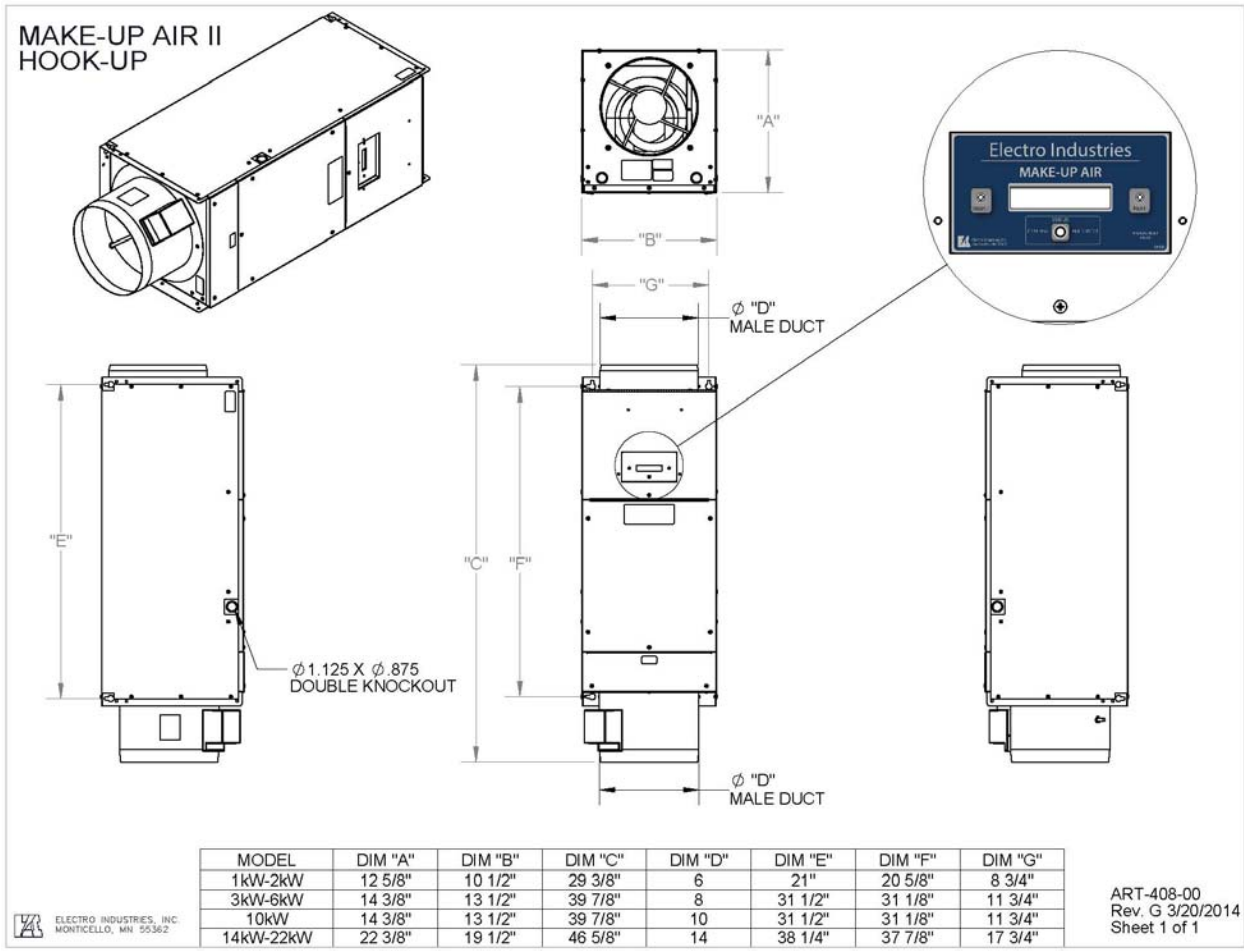

Safety Consideration

WARNING

BEFORE PERFORMING SERVICE OR MAINTENANCE OPERATIONS ON A SYSTEM, TURN OFF MAIN POWER SWITCHES TO THE INDOOR UNIT. IF APPLICABLE, TURN OFF THE ACCESSORY HEATER POWER SWITCH. ELECTRICAL SHOCK COULD CAUSE PERSONAL INJURY.

Installing and servicing electric heating equipment can be hazardous due high voltage and electrical components. Only trained and qualified service personnel should install, repair or service heating and air conditioning equipment. Untrained personnel can perform the basic maintenance functions of cleaning coils and cleaning and replacing filters. All other operations should be performed by trained service personnel. When working on heating and air conditioning equipment, observe precautions in the literature, tags and labels attached to the unit and other safety precautions that may apply, such as the following safety measures:

- Follow all safety codes.
- Wear safety glasses and work gloves.

Installation Requirements

1. All installation work must be performed by trained, qualified contractors or technicians. Electro Industries sponsors installation and service schools to assist the installer. **Visit our Website at www.electromn.com for upcoming service schools.**

WARNING

ALL ELECTRICAL WIRING MUST BE IN ACCORDANCE WITH NATIONAL ELECTRIC CODE AND LOCAL ELECTRIC CODES, ORDINANCES, AND REGULATIONS.

WARNING

OBSERVE ELECTRIC POLARITY AND WIRING COLORS. FAILURE TO OBSERVE COULD CAUSE ELECTRIC SHOCK AND/OR DAMAGE TO THE EQUIPMENT.

CAUTION

This unit can only be used for its intended design as described in this manual. Any internal wiring changes, modifications to the circuit board, modifications or bypass of any controls, or installation practices not according to the details of this manual will void the product warranty, the safety certification label, and manufacturer product liability. Electro Industries cannot be held responsible for field modifications, incorrect installations, and conditions which may bypass or compromise the built-in safety features and controls.

CAUTION

This unit shall not be operated (either heating section or blower) until the interior of the structure is completed and cleaned. This also means all duct work must be complete with filter, etc. Manufacturer's warranty is void if this unit is operated during structure construction.

CAUTION

Hazards or unsafe practices could result in property damage, product damage, severe personal injury and/or death.

2. At Electro Industries the safety of the installer and the end user is of highest priority. Remember, safety is the installer's responsibility and the installer must know this product well enough to instruct the end user on its safe use. Professional installers should be trained and experienced in the areas of handling electrical components, sheet metal products, and material handling processes.

Installation Overview

This Make-Up Air unit contains interface/logic devices, outlet temperature sensor, power open/spring close damper, permanent washable filter and fan motor. Based on the application, other system components may be required to make your system operate as desired. These components must be provided by the installing contractor. These components may include but are not limited to:

- Outside inlet hood
- Insulated inlet ducting
- Outlet ducting
- The turn-on method or switch
 - Remote damper with END switch (also see Control Wiring section)
 - Current sensing switch, building exhaust fan/blower
 - Relay contact detecting the building exhaust fan/blower running
- Source power wiring

Refer to the below diagrams which show various system configurations.

Make-Up Air Independent System

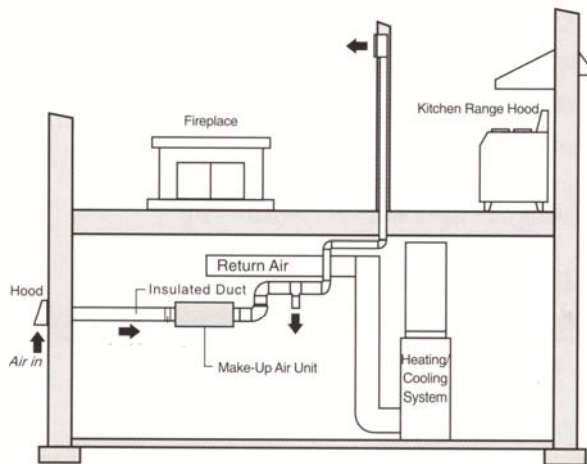

Make-Up Air Combined Return Tie-In & Independent System

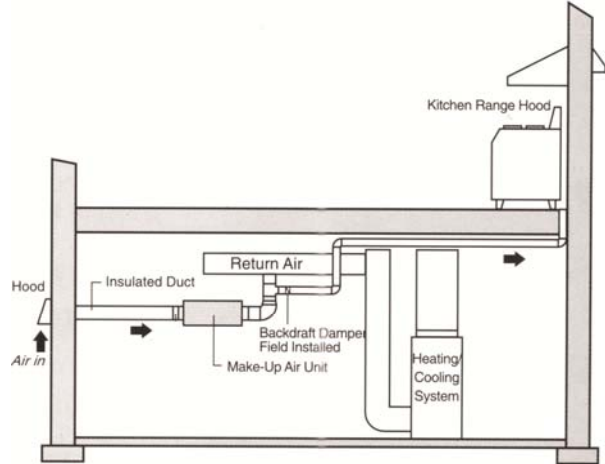

Make-Up Air Return Tie-In System

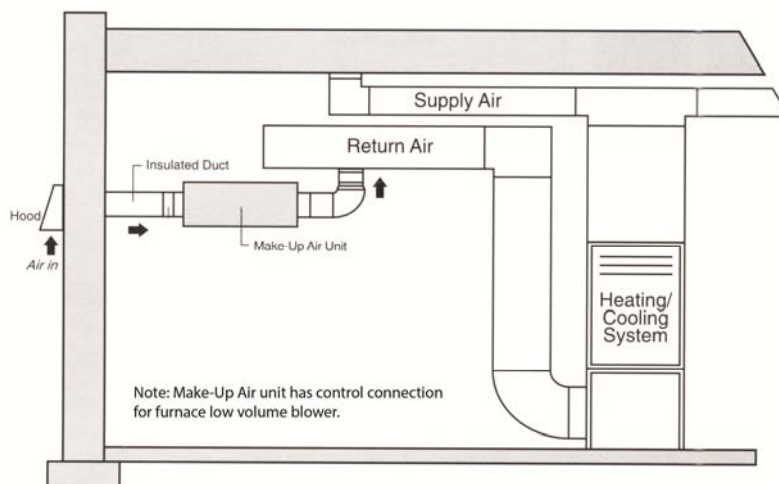

Mechanical Installation

This product is designed for zero clearance, but use the following mounting and spacing criteria:

1. Unit can be installed vertically or horizontally. When vertical, inlet must face down.
2. Observe the airflow direction decal and the “inlet” decal.
3. Make mounting provisions for a 1” air space at the top.
4. The sides, any location, can be in direct contact with wood framing materials.
5. No materials shall be in contact with the cabinet housing which has a flame point less than wood, 300°F (150°C).
6. Product shall be installed in a conditioned space only.
7. Heating elements are locked out when outlet air temperature is > set point dial switch.

General:

1. Select a location which will provide minimal noise vibration and minimal fan noise to the building occupants.
2. The outside hood and ducting material are not included with this unit. It is the installer’s responsibility to provide the necessary weather protection for the inlet.
 - In cold climates, insulated ducting **must** be used between the outside inlet air hood and the inlet of this unit.
3. Install unit with a slight air inlet incline (housing outlet end is ¼” higher than inlet end).
4. The unit can be mounted within the ceiling (between joists where it will fit) or ceiling hung, at any convenient location between the outside inlet hood and the fresh air discharge connection.
 - The “discharge connection” is wherever the conditioned fresh air is distributed within the building – furnace cold air return, special ducting, hallway register, furnace room, etc.
5. 6” inlet and outlet ducting is adequate for these two mini models.

Note: In cold climates, frost and or condensation may collect on metal parts of this product. External field provided insulation may be required in certain situations. The inlet damper and insulated inlet piping will prevent cold air migration and a slight incline will keep moisture collection at the inlet end.

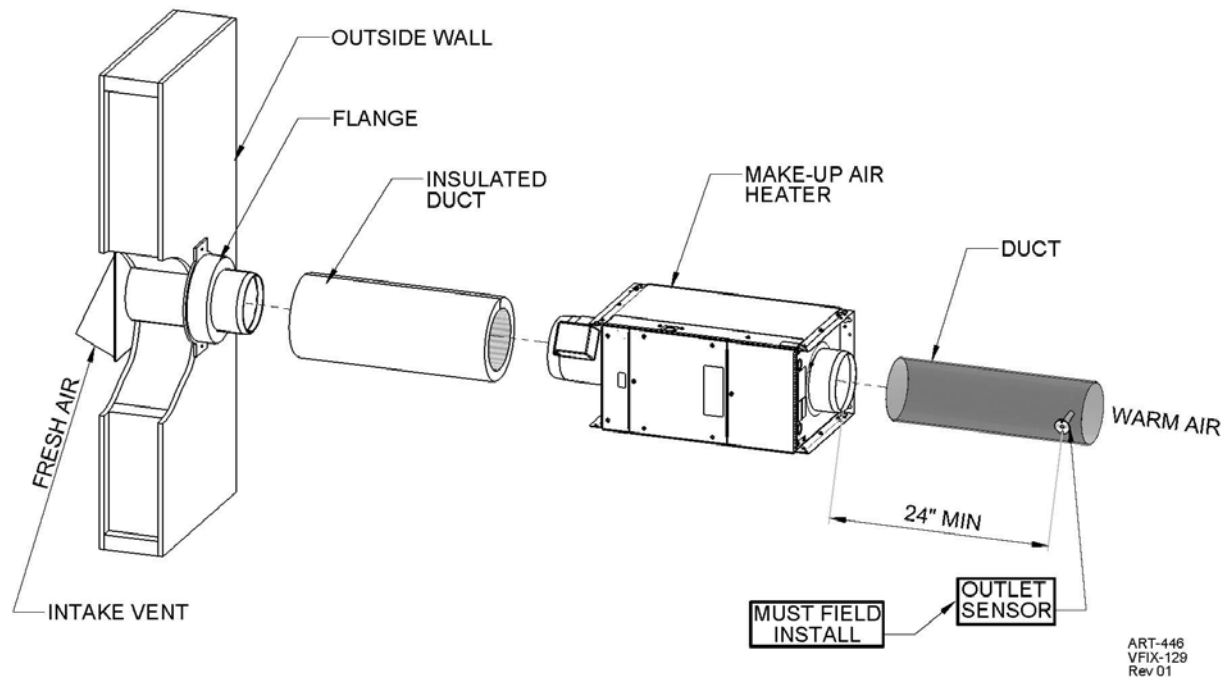

Horizontal installation – Ceiling Mount

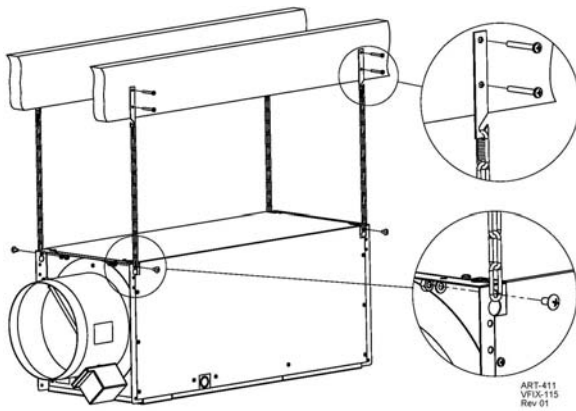

Vertical Installation – Wall Mount

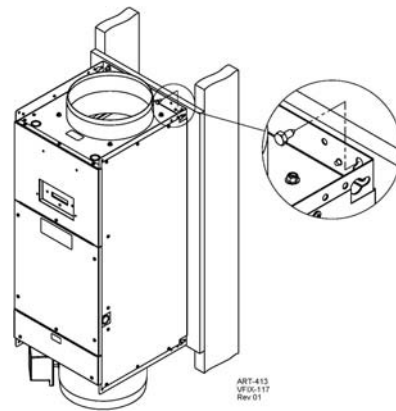

Horizontal installation – Wall Mount

Option A: Cover Facing Down

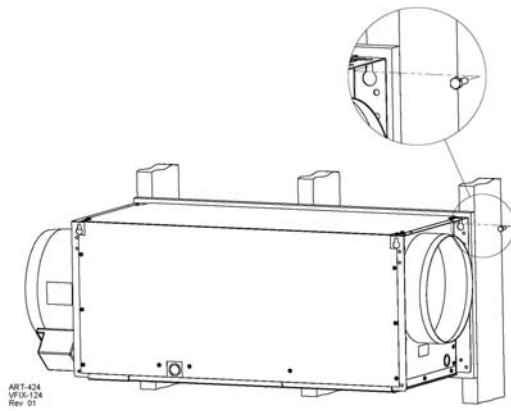

Option B: Cover Facing Side

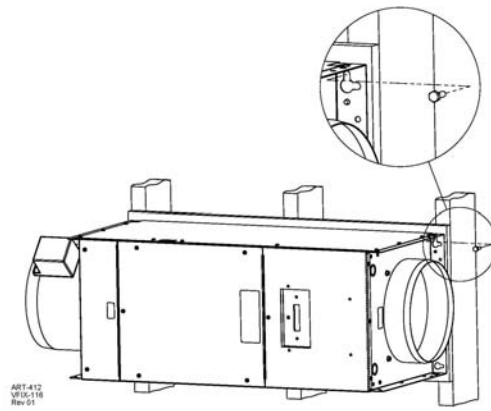

Electrical Installation

Temperature Sensor

Heated air outlet temperature sensor is included. **Without proper installation of this probe the Make-Up Air unit will not operate correctly.**

The sensor probe/cable is attached to the control board. However, the sensor probe must be installed external to this unit. Install in the warm air outlet duct, 24" to 36" away from discharge fan.

Control Wiring

Dry Type Switch Contact

This "on and off" control contact applied across R and W depends upon installation requirements and can take on several possibilities:

- Pressure differential switch
- CT with integrated switch contact
- Relay across exhaust blower motor
- End switch associated with exhaust damper/motor

Connection Details

Connect one side of the field provided switch to the TB1 "R" and the other side of the switch to the TB1 "W".

External Damper, Field Furnished and Installed

If this installation requires or desires a power damper at the through-wall hood, this can be field furnished and wired using the following guidelines:

Required is a 24VAC power to open, **spring** close.

Note: It is assumed the existing power damper will be removed, damper blocked open, or actually used in parallel with the field added damper.

External damper without end switch:

1. Locate the two wires connected to the existing damper (violet and gray).
2. Splice and extend these two wires (powered to open) to the external damper, powered to open.

External damper with end switch:

1. The external damper motor is driven from the **exhaust** blower turn-on contact closure or device.
2. Locate the external damper END switch closed when open contact terminals or two wires.
3. Extend these two wires to the R and W terminal block.
4. Sequence:
 - a. With this arrangement (paragraph 1 above) there is no other turn-on device (current switch, thermostat, airflow switch, etc.)
 - b. When the **exhaust** blower comes on, that same component or mechanism also opens this external damper.
 - c. When the external damper end switch closes it turns on this Make-Up Air unit, at R to W.
 - d. All other functions now begin with the R to W turn-on.

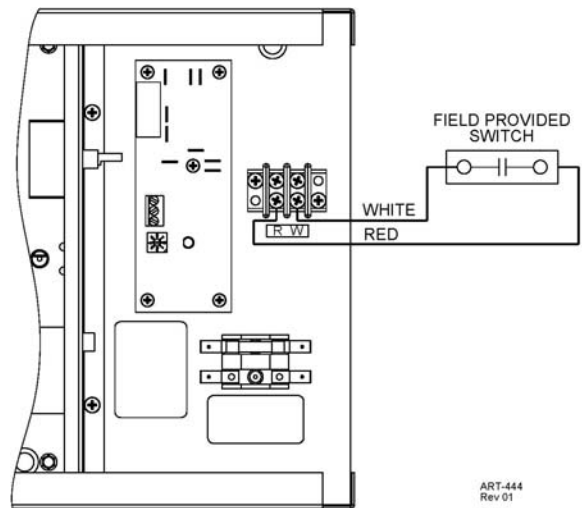

High Voltage Hookup

Service Panel Circuit Breaker(s) Sizing – based upon unit size, the specification page shows appropriate service size requirements based on UL and NEC code.

Note: These two models require 120VAC source (not 240).

Source Power – route and install proper current carrying conductors as per local code requirements, from service panel. Nameplate shows current and kW rating. Use **copper wire only**.

Safety Ground – copper wire is required, do not depend upon metal conduit.

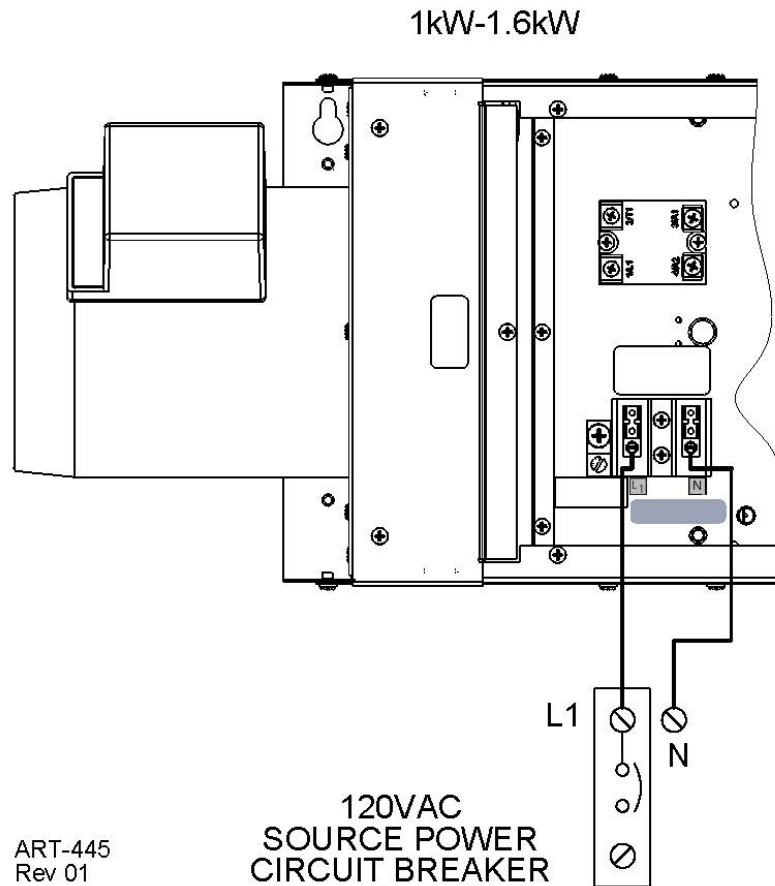

Basic Setup

Temperature Set Point – Located on the control board is a dial labeled “SW1”. This dial is used to set the desired output temperature.

Setting the desired output temperature is completed in two steps. See **Figure 1** for temperature ranges.

- **Step 1** – Determine the required temperature output for the application.
 - **HINT:** Most Make-Up Air applications suggest an output set point typically around 50°F.
- **Step 2** – using a small screwdriver, adjust the SET POINT dial according to the desired operating temperature.

FIGURE 1

“SET POINT” Switch Position	°F
0	20
1	25
2	30
3	35
4	40
5	45
6	50
7	55

Factory default, position 6 (50° F)

Fan Speed Adjustment – located in the hinged cover low voltage compartment and on the divider is a plastic shaft “knob” which allows for fine tuning the fan speed. If you do not need full CFM for your application and desire a larger temperature rise, the lower factory default set speed may be adequate. However, you must realize the CFM must maintain the appropriate requirement for balancing the building inlet to the outlet mechanical driven air.

NOTE: Factory default setting is low, full CW. To increase speed turn dial CCW.

COMMENT: The fan low speed CFM is approximately 120.

Operational Indicators

Green LED – on control board.

- Full on = low voltage present and okay, micro controller is functioning, etc.
- One pulse = electric heating element is active (set point is still controlling actual element on/off).
- Two pulses = bad outlet temperature sensor.
- Three pulses = control hi-limit open.

R to W closed contact – external switch device.

- Fan is running.
- Inlet damper is opening and held open.
 - Inlet damper is spring close.
- Control board – heat active (set point is still controlling actual element on/off).

Fan relationship to electric heating elements – fan comes on immediate with R to W contact. There is a 30-second delay before elements turn on (outlet sensor needs to measure inlet air, not room air). The fan also purges the inside elements and warm air after R to W is open for 60 seconds.

Hi-limit, manual reset – all operations seem normal, but the heating element power is interrupted.

- The reset button is in the hinged door compartment, on control box divider.

Auto reset hi-limits – there are two.

- Temperature control, at fan inlet, this is set for an approximate 90° outlet temperature. It is in the low voltage logic control circuit. LED will show 3 pulses.
- Comment – this is in addition to the outlet temperature sensor mounted within the discharge duct which responds to the set point temperature dial.
- Element current carrying leg – within the sheet metal housing/inside deflectors, this is a safety hi-limit in case there is a fan failure or major inlet air restriction.

Disconnected or bad detected sensor – LED will show two pulses. The electric elements or heat active is at 100% on, follows the R-W input. With an inactive duct sensor the electric elements are no longer controlled at set point.

Troubleshooting

1. This product contains several interference suppression components, but as an electronic logic product unpredictable and unusual transients or interferences may sometimes cause strange results. If this product is “acting strange”, turn off the source power, count to 10, and reenergize.
2. Terminal blocks are clamp-down type. If there is no wire connected and the screw is loose, the screw may not necessarily make a good electrical contact to the inside components. Example – if you are jumpering the thermostat terminals without thermostat wire connection or if you are attempting to measure voltage on a screw head, you may get erroneous or unpredictable results if the screw is not tightened down.
3. Use general heating system logic information and basic understanding of the terminal block wiring functions when measuring voltage to determine proper operation of this module.

Outlet Temperature Sensor

See previous page relating to LED indication and bad sensor operation.

The green LED is an indication that the micro program cannot read a temperature value. This sensor test or indication does not determine a bad temperature reading, it simply indicates there is software communication to the sensor itself.

Temperature Sensor Detail

- Red wire to J2-1 +5VDC or “RED”
- Black wire to J2-2 “DATA” or “BLK”
- White wire to J2-3 COM or “WHT”

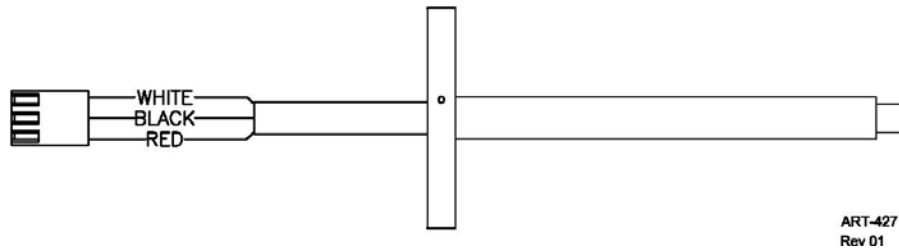

Air Filter

A dirty filter can lead to poor system performance and eventual hi-limiting. It is suggested to wash filter at least twice per year. See **Routine Maintenance** for instruction on how to wash the filter.

Control Fuse

The low voltage source fuse is a 2A fast blow. A spare fuse is included (next to the operating fuse).

Manual Reset Hi-Limit

Inside the hinged door compartment is a small red button for manually resetting the highest temperature safety cutout limit. The small red stem will be out approximately ¼”, and there is a “snap” feeling if it was activated or opened. Using indicator lights, etc. to troubleshoot this manual reset must be carefully thought through. The four indicators are:

- Control board LED, one pulse
- SSR (triac) LED will be on
- No element amps or current
- No heat

COMMENT: A bad SSR (triac) may have the same observation as an activated manual reset, diagnose carefully.

Routine Maintenance

Filter – this unit includes an air filter which is a permanent and washable filter.

Suggest at least twice per year removing filter and using standard household water to back flush collected dust/debris.

- Remove screws from small door, opposite the hinged door end
- Filter is simply held within channels

Replacement Parts

Part Number	Description
4037KIT	REPLACE TRIAC SSR 50AMP 24-280 VAC
4341	BLOWER SPEED CONTROL 120V
5541	TRANSFORMER 120/240:24 40VA CHNN
5609	LIMIT O-100/C-AMP @ VAC
5610	LIMIT O-99/C-85 10AMP @240VAC
5611	LIMIT 150F CAP BULB MAN RESET
5621	ELEMENT EM RND 2.5@240 23 OHM
6613	ELEMENT WX 1@120 14.6 OHM
EMMUM5614	PCB MUA II 1&2KW WF ONLY/ KNOB SPD
UFUSE0440	FUSE 2A 250V GLASS FAST ACT
VLUG5527	LUG 2 POLE 4-14AWG 4-.250 QUICK CONNECT

MAKE-UP AIR II 1 & 2kW

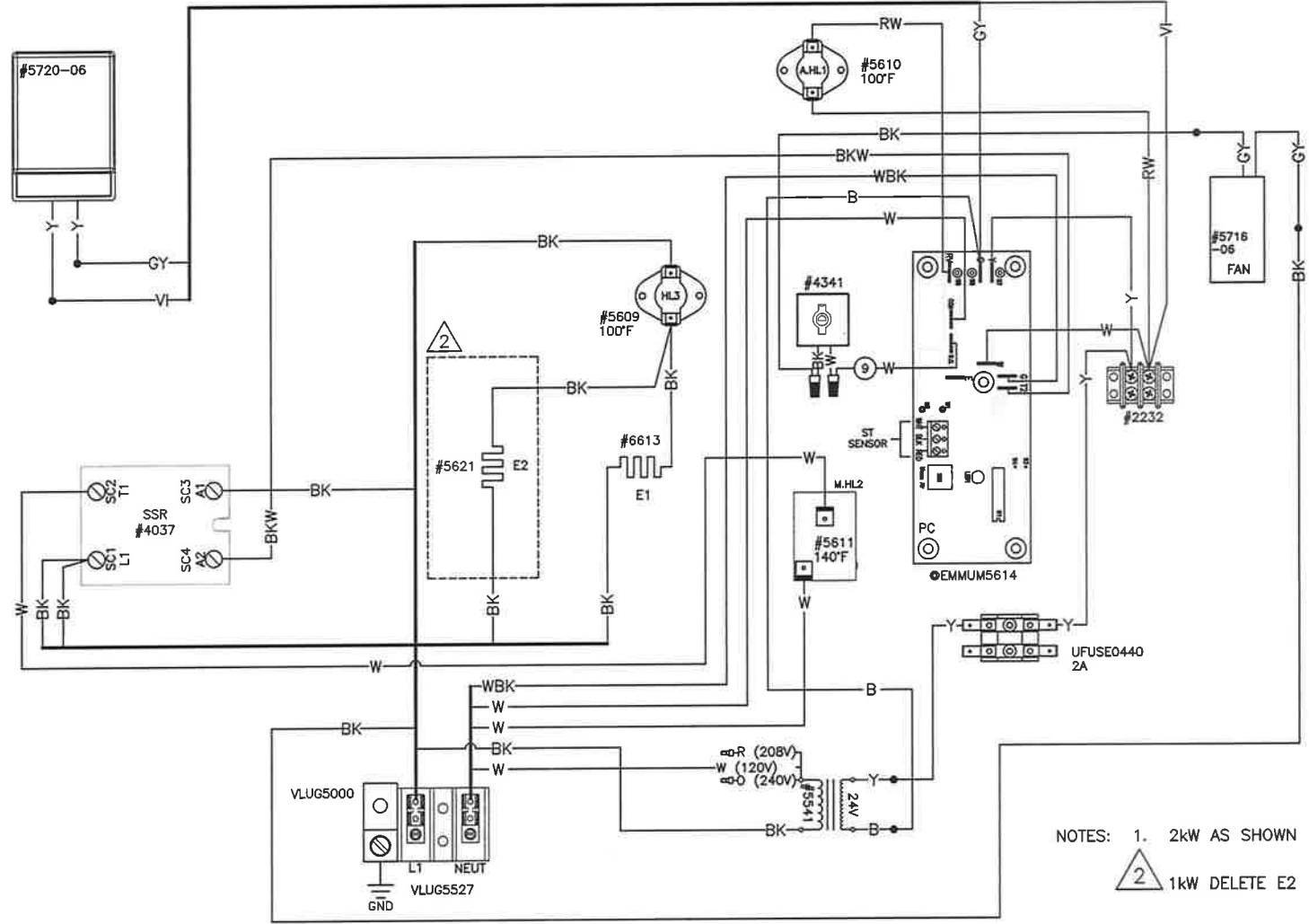

COMPONENT CODE	
E1	1000W ELEMENT
E2	2500W ELEMENT
HL	HI-LIMIT
PC	CIRCUIT BOARD
T	TAB TERMINAL
SC	SCREW TERMINAL
RELAY STAGING	
1	SSR
WIRE COLOR CODE	
BK	BLACK
BKW	BLACK/WHITE
B	BLUE
OR	ORANGE
R	RED
RW	RED/WHITE
Y	YELLOW
W	WHITE
WBK	WHITE/BLACK
GY	GRAY
VI	VIOLET

NOTES: 1. 2kW AS SHOWN
 2. 1kW DELETE E2

DECAL
UAW873
 Rev 02 7-16-2014

Electro Industries, Inc. Residential Limited Product Warranty

Effective November 1, 2009

Electro Industries, Inc. warrants to the original owner, at the original installation site, for a period of two (2) years from date of original purchase, that the product and product parts manufactured by Electro Industries, Inc. are free from manufacturing defects in materials and workmanship, when used under normal conditions and when such product has not been modified or changed in any manner after leaving the plant of Electro Industries, Inc. If any product or product parts manufactured by Electro Industries, Inc. are found to have manufacturing defects in materials or workmanship, such will be repaired or replaced by Electro Industries, Inc. Electro Industries, Inc., shall have the opportunity to directly, or through its authorized representative, examine and inspect the alleged defective product or product parts. Electro Industries, Inc. may request that the materials be returned to Electro Industries, Inc. at owner's expense for factory inspection. The determination as to whether product or product parts shall be repaired, or in the alternative, replaced, shall be made by Electro Industries, Inc. or its authorized representative.

Electro Industries, Inc. will cover labor costs according to the Repair / Replacement Labor Allowance Schedule for a period of ninety (90) days from the date of original purchase, to the original owner, at the original installation site. The Repair / Replacement Labor Allowance is designed to reduce the cost of repairs. This Repair / Replacement Labor Allowance may not cover the entire labor fee charged by your dealer / contractor.

TWENTY YEAR (20) LIMITED WARRANTY ON BOILER ELEMENTS AND VESSELS

Electro Industries, Inc. warrants that the boiler elements and vessels of its products are free from defects in materials and workmanship through the twentieth year following date of original purchase. If any boiler elements or vessels are found to have a manufacturing defect in materials or workmanship, Electro Industries, Inc. will replace them.

TWENTY YEAR (20) LIMITED WARRANTY ON SPIN FIN ELEMENTS

Electro Industries, Inc. warrants that the spin fin elements of its products are free from defects in materials and workmanship through the twentieth year following date of original purchase. If any spin fin elements are found to have a manufacturing defect in materials or workmanship, Electro Industries, Inc. will replace them.

FIVE YEAR (5) LIMITED WARRANTY ON OPEN WIRE ELEMENTS

Electro Industries, Inc. warrants that the open wire elements of its products are free from defects in materials and workmanship through the fifth year following date of original purchase. If any open wire elements are found to have a manufacturing defect in materials or workmanship, Electro Industries, Inc. will replace them.



ELECTRO INDUSTRIES, INC.

2150 West River Street, PO Box 538, Monticello, MN 55362
763.295.4138 • 800.922.4138 • fax 763.295.4434
sales@electromn.com • www.electromn.com

CONDITIONS AND LIMITATIONS:

1. This warranty is limited to residential, single family dwelling installations only. Any commercial or multi-unit dwelling installations fall under the Electro Industries Commercial Limited Product Warranty.
2. Electro Industries, Inc. shall not be liable for performance related issues resulting from improper installation, improper sizing, improper duct or distribution system, or any other installation deficiencies.
3. If at the time of a request for service the original owner cannot provide an original sales receipt or a warranty card registration then the warranty period for the product will have deemed to begin the date the product is shipped from the factory and **NOT** the date of original purchase.
4. The product must have been sold and installed by a licensed electrician, plumbing, or heating contractor.
5. The application and installation of the product must be in compliance with Electro Industries, Inc. specifications, as stated in the installation and instruction manual, and all state, provincial and federal codes and statutes. If not, the warranty will be null and void.
6. The purchaser shall have maintained the product in accordance with the manual that accompanies the unit. Annually, a qualified and licensed contractor must inspect the product to assure it is in proper working condition.
7. All related heating components must be maintained in good operating condition.
8. All lines must be checked to confirm that all condensation drains properly from the unit.
9. Replacement of a product or product part under this limited warranty does not extend the warranty term or period.
10. Replacement product parts are warranted to be free from defects in material and workmanship for ninety (90) days from the date of installation. All exclusions, conditions, and limitations expressed in this warranty apply.
11. Before warranty claims will be honored, Electro Industries, Inc. shall have the opportunity to directly, or through its authorized representative, examine and inspect the alleged defective product or product parts. Remedies under this warranty are limited to repairing or replacing alleged defective product or product parts. The decision whether to repair or, in the alternative, replace products or product parts shall be made by Electro Industries, Inc. or its authorized representative.

THIS WARRANTY DOES NOT COVER:

1. Costs for labor for diagnosis, removal or reinstallation of an alleged defective product or product part, transportation to Electro Industries, Inc., and any other materials necessary to perform the exchange, except as stated in this warranty. Replacement material will be invoiced to the distributor in the usual manner and will be subject to adjustment upon verification of defect.
2. Any product or product part that has been damaged as a result of being improperly serviced or operated, including, but not limited to, the following: operated during construction phase, with insufficient water or air flow; allowed to freeze; subjected to flood conditions; subjected to improper voltages or power supplies; operated with air flow or water conditions and/or fuels or additives which cause unusual deposits or corrosion in or on the product; chemical or galvanic erosion; improper maintenance or subject to any other abuse or negligence.
3. Any product or product part that has been damaged as a result of natural disasters, including, but not limited to, lightning, fire, earthquake, hurricanes, tornadoes or floods.
4. Any product or product part that has been damaged as a result of shipment or handling by the freight carrier. It is the receiver's responsibility to claim and process freight damage with the carrier.
5. Any product or product part that has been defaced, abused or suffered unusual wear and tear as determined by Electro Industries, Inc. or its authorized representative.
6. Workmanship of any installer of the product or product part. This warranty does not assume any liability of any nature for unsatisfactory performance caused by improper installation.
7. Transportation charges for any replacement product, product part or component, service calls, normal maintenance; replacement of fuses, filters, refrigerant, etc.

THESE WARRANTIES DO NOT EXTEND TO ANYONE EXCEPT THE ORIGINAL PURCHASER AT RETAIL AND ONLY WHEN THE PRODUCT IS IN THE ORIGINAL INSTALLATION SITE. THE REMEDIES SET FORTH HEREIN ARE EXCLUSIVE.

ALL IMPLIED WARRANTIES, INCLUDING WARRANTIES OF MERCHANTABILITY AND FITNESS FOR A PARTICULAR PURPOSE, ARE HEREBY DISCLAIMED WITH RESPECT TO ALL PURCHASERS OR OWNERS. ELECTRO INDUSTRIES, INC. IS NOT BOUND BY PROMISES MADE BY OTHERS BEYOND THE TERMS OF THESE WARRANTIES. FAILURE TO RETURN THE WARRANTY CARD SHALL HAVE NO EFFECT ON THE DISCLAIMER OF THESE IMPLIED WARRANTIES.

ALL EXPRESS WARRANTIES SHALL BE LIMITED TO THE DURATION OF THIS EXPRESS LIMITED WARRANTIES SET FORTH HEREIN AND EXCLUDE ANY LIABILITY FOR CONSEQUENTIAL OR INCIDENTAL DAMAGES RESULTING FROM THE BREACH THEREOF. SOME STATES OR PROVINCES DO NOT ALLOW THE EXCLUSION OR LIMITATION OF INCIDENTAL OR CONSEQUENTIAL DAMAGES, SO THE ABOVE LIMITATIONS OR EXCLUSIONS MAY NOT APPLY. PRODUCTS OR PARTS OF OTHER MANUFACTURERS ATTACHED ARE SPECIFICALLY EXCLUDED FROM THE WARRANTY.

THIS WARRANTY GIVES YOU SPECIFIC LEGAL RIGHTS, AND YOU MAY HAVE OTHER RIGHTS WHICH VARY UNDER THE LAWS OF EACH STATE. IF ANY PROVISION OF THIS WARRANTY IS PROHIBITED OR INVALID UNDER APPLICABLE STATE OR PROVINCIAL LAW, THAT PROVISION SHALL BE INEFFECTIVE TO THE EXTENT OF THE PROHIBITION OR INVALIDITY WITHOUT INVALIDATING THE REMAINDER OF THE AFFECTED PROVISION OR THE OTHER PROVISIONS OF THIS WARRANTY.