

Model **PS-HAI**

Filter hood

A

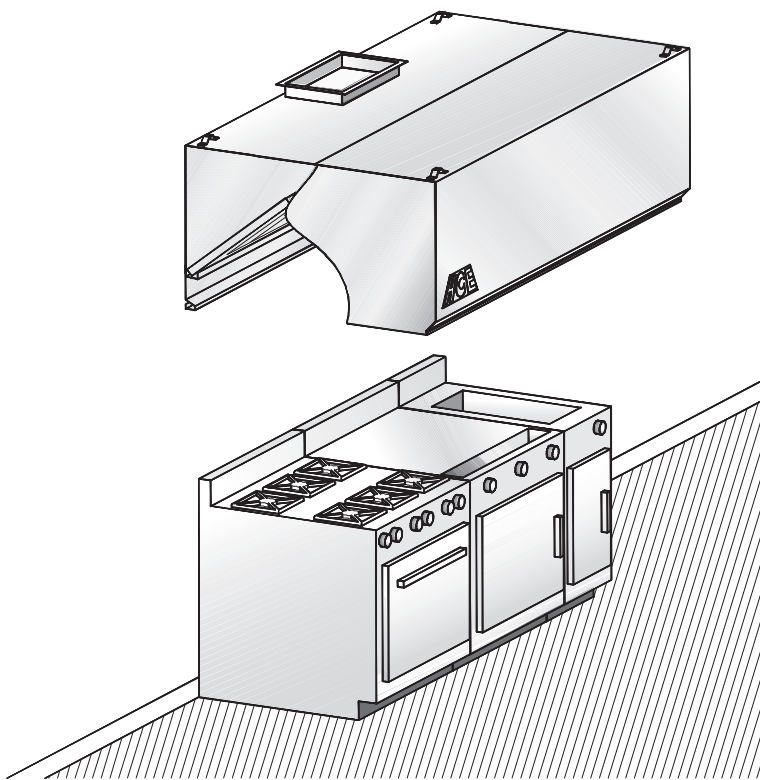

Description :

HCE wall-type exhaust hood model PS-HAI complete with baffle filters.

Specifications:

- Constructed of sturdy 18-gauge (1.2 mm) stainless steel.
- Available in lengths of 3' 0" to 16' 0" (914 mm to 4,877 mm)
- Washable baffle filters
- Easy installation
- Listed 
- Many options available (see reverse)
- Quick delivery

Construction :

Exposed hood surface: type 430 stainless steel (304 optional) with #4 finish (brushed). Non-exposed hood surface: stainless steel with #2B finish. Minimum 18-gauge (1.2 mm) thickness. All visible welded joints are polished to match original finish. To meet NFPA- 96 requirements.

Installation :

Suspension (recommended height)

The hood should be installed 6' 6" (1,981 mm) from the floor.

Semi-combustible materials

A clearance of 3" (76 mm) is required when the hood is in contact with semi-combustible materials. As per NFPA-96 standards, a stainless steel spacer will be required.

Enclosure panels (optional):

The space between the top of the hood and the ceiling may be closed with stainless steel panels in the same finish as the hood.

Electrical:

Junction box and pre-wiring for lighting system may be factory installed if required.

Suggested model

- Restaurant chains
- Higher output kitchens
Steak houses

Length		Exhaust		Collar/opening 12" (305 mm) x _____	
Feet	mm	CFM	L/S	Inches	mm
3'-6"	1068	1225	580	12	305
4'-0"	1220	1400	660	12	305
4'-6"	1372	1575	745	14	355
5'-0"	1524	1750	825	16	405
5'-6"	1676	1925	910	18	455
6'-0"	1828	2100	990	18	455
6'-6"	1981	2275	1075	20	510
7'-0"	2134	2450	1155	22	560
7'-6"	2286	2625	1240	24	610
8'-0"	2438	2800	1320	26	660
8'-6"	2590	2975	1400	26	660
9'-0"	2743	3150	1485	28	710
9'-6"	2895	3325	1570	30	760
10'-0"	3048	3500	1650	32	810
10'-6"	3200	3675	1735	(2) 16	(2) 405
11'-0"	3352	3850	1815	(2) 18	(2) 455
11'-6"	3505	4025	1900	(2) 18	(2) 455
12'-0"	3657	4200	1980	(2) 18	(2) 455
12'-6"	3810	4375	2065	(2) 20	(2) 510
13'-0"	3962	4550	2145	(2) 20	(2) 510
13'-6"	4115	4725	2230	(2) 22	(2) 560
14'-0"	4267	4900	2310	(2) 22	(2) 560
14'-6"	4420	5075	2395	(2) 22	(2) 560
15'-0"	4572	5250	2475	(2) 24	(2) 610
15'-6"	4724	5425	2560	(2) 24	(2) 610
16'-0"	4877	5600	2640	(2) 26	(2) 660

* Exhaust for 42" (1,065 mm) and 48" (1,220 mm)-deep hoods. Contact us for assistance to determine the appropriate air volume.

Accessories included:

- 1 Exhaust collar (3" high)
- 2 Used grease receptacle
- 3 cULus-listed galvanized steel baffle filters

Optional accessories: (see section "K" for details)

- A cULus-listed exhaust collar with fire damper
- B cULus-listed exhaust collar with balancing damper
- C Incandescent lights (Quantity recommended: (1) light per 5 linear feet of hood)
- D Wire guard for incandescent lights
- E 36" or 48" fluorescent lights (Quantity recommended: (1) light per 8 linear feet of hood)
- F Junction box and pre-wiring for lighting
- G 3" spacer for clearance to meet NFPA- 96 requirements
- H Enclosure panels, stainless steel with #4 finish, between hood and ceiling
- I PAC-02 programmable control panel
- J End skirts should be used to maximize hood performance
- K Hanging brackets
- L cULus-listed stainless steel baffle filters

A

Filter hood

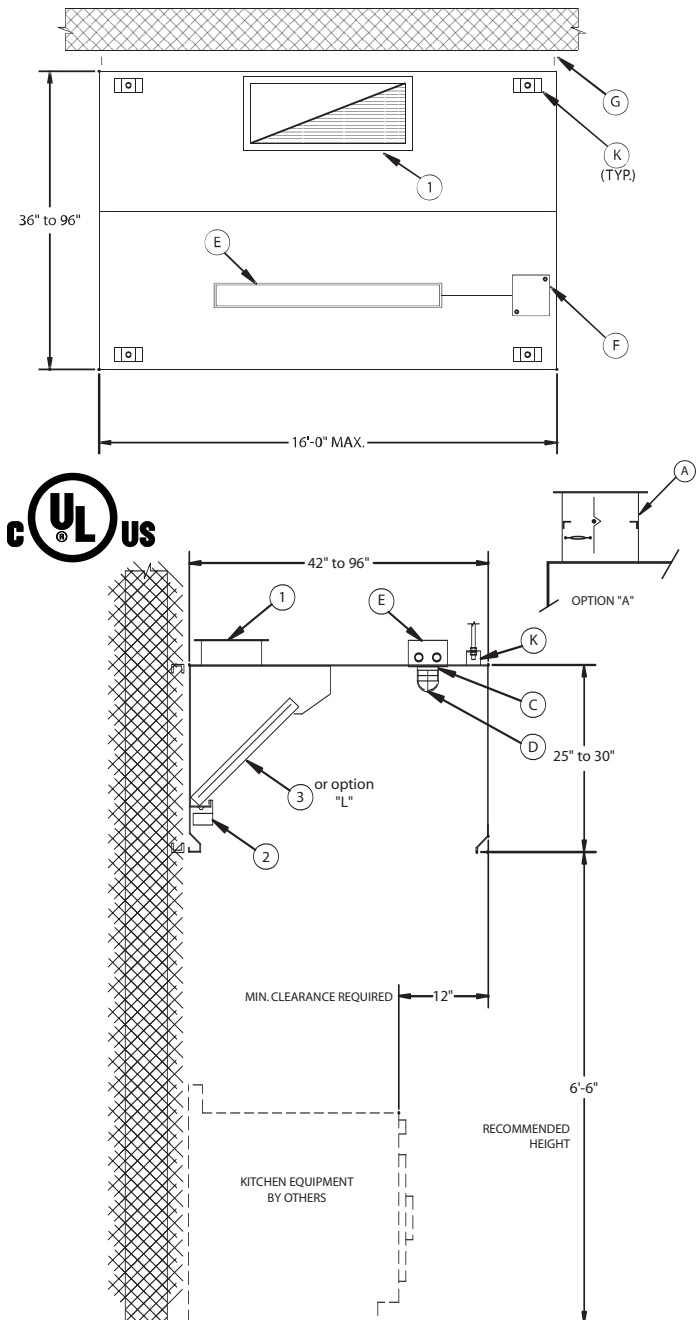

	Exhaust VOLUME (CFM / Lin. Ft.)	Internal pressure loss (IN / H ₂ O)	Exhaust VOLUME (L/S per linear metre)	Internal pressure loss (Pa)
Light cooking	175	0,30	270	75
Medium cooking	260	0,40	400	100
Heavy cooking	350	0,60	540	150