

**ATTIF**

**(Analysis of Train/Track Interaction Forces)**

## Table of Contents

<b>1.</b>	<b>INTRODUCTION TO ATTIF</b>	<b>1</b>
1.1	Overview	1
1.2	Code Structure	1
1.3	Installing ATTIF	2
<b>2.</b>	<b>GETTING STARTED</b>	<b>3</b>
2.1	Introduction to the ATTIF Interface	3
2.2	Sections of the Interface	4
2.2.1	Menu Bar	4
2.2.1.1	File Dropdown Menu	4
2.2.1.1	Edit Dropdown Menu	7
2.2.1.1	View Dropdown Menu	7
2.2.1.1	Data Dropdown Menu	8
2.2.1.1	Simulation Dropdown Menu	8
2.2.1.1	Results Dropdown Menu	9
2.2.1.1	Help Dropdown Menu	10
2.2.2	Tool Bar	10
2.2.3	Panel Buttons	11
2.2.4	Feature Selection	11
2.2.5	Status Bar	12

2.2.6	Data Input Panels	12
2.2.7	Panel Tabs	12
2.2.8	Graphics Window	13
<b>3.</b>	<b>LONGITUDINAL TRAIN MODELING IN ATTIF</b>	<b>14</b>
3.1	Data Entry	14
3.1.1	Cars Tab	15
3.1.1.1	Body Sub-Tab	16
3.1.1.2	Degrees of Freedom Sub-Tab	18
3.1.1.3	Resistance Sub-Tab	19
3.1.1.4	Locomotive Engine/Brake Sub-Tab	20
3.1.1.5	Adhesion Sub-Tab	21
3.1.1.6	Wheels & Axels Sub-Tab	22
3.1.1.7	Brake Sub-Tab	23
3.1.1.8	Graphics Sub-Tab	24
3.1.2	Couplers Tab	24
3.1.3	Air Brake Tab	27
3.1.4	Track/Spline Tab	31
3.1.5	Recorded Control Tab	32
3.1.6	Springs Tab	32
3.1.7	Bearings Tab	33
3.1.8	Simulation Parameters Tab	34

3.1.9	3D Window Settings Tab	35
3.1.10	Bushing Tab	36
3.1.11	Pin Joint Tab	36
3.1.12	Contact Tab	37
<b>4.</b>	<b>MODEL EXAMPLES</b>	<b>40</b>
4.1	Example #1: 5 car consist of 1-Body vehicles	40
4.2	Example #2: 15 car consist of 3-Body vehicles	52
4.3	Example #3: 15 car consist including Detailed Contact Car	61
	<b>APPENDIX</b>	<b>70</b>
	General Data File	70
	General Data File – Contact	76

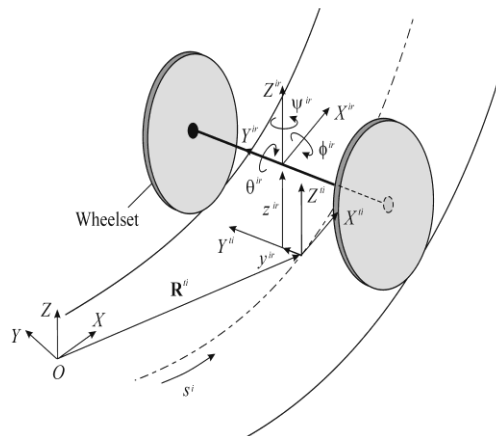
# 1. INTRODUCTION TO ATTIF

## 1.1 Overview

The objective of this manual is to describe the use and capabilities of the computer program ATTIF, which can be used in dynamic simulation of multibody system applications, and more specifically, railroad train/track interaction. ATTIF (Analysis of Train/Track Interaction Forces) systematically treats interconnected rigid bodies utilizing a nonlinear trajectory coordinate formulation scheme to provide computationally less expensive simulations without disregarding the data accuracy of the analysis. ATTIF provides the ability to simulate accident investigations, train configuration evaluations, operating speeds, user-created track scenarios and a variety of other features of train/track research interest. The theory used to develop the ATTIF code is documented in several texts and published papers which clearly explain the formulations and computer algorithms implemented. Using these references, the user can have a comprehensible understanding of the structure of the equations of motion used as well as the formulation of various force and constraint elements included in the code library. The following chapters discuss ATTIF's features and provide the user with a selection of examples to act as a guide for performing their own simulations. It is highly recommended that the user read the entirety of this manual to be completely familiarized with the software before performing any simulations.

## 1.2 Code Structure

To achieve the goal of computationally inexpensive long-train simulations, ATTIF uses a trajectory coordinate system which defines each rail car component's configuration with respect to the body's trajectory along the space curve of the track, as shown in Fig.1.1. The equations of motion for each body of the railcar are then derived using the Newton-Euler equations and expressed as trajectory coordinates. These trajectory coordinates are, in turn, used to simulate the traction and braking of the railcar.



**Figure 1.1** - Trajectory coordinates

The following form of the Newton-Euler equation is used in ATTIF:

$$\begin{bmatrix} m^i \mathbf{I} & \mathbf{0} \\ \mathbf{0} & \bar{\mathbf{I}}_{\theta\theta}^i \end{bmatrix} = \begin{bmatrix} \ddot{\mathbf{R}}^i \\ \ddot{\boldsymbol{\alpha}}^i \end{bmatrix} = \begin{bmatrix} \mathbf{F}_e^i \\ \bar{\mathbf{M}}_e^i - \bar{\boldsymbol{\omega}}^i \times (\bar{\mathbf{I}}_{\theta\theta}^i \bar{\boldsymbol{\omega}}^i) \end{bmatrix}$$

where  $m^i$  is the mass of the rigid body;  $\mathbf{I}$  is a  $3 \times 3$  identity matrix;  $\bar{\mathbf{I}}_{\theta\theta}^i$  is the inertial tensor defined with respect to the body coordinate system;  $\mathbf{F}_e^i$  is the resultant of the external forces applied on the body defined in the global coordinate system; and  $\bar{\mathbf{M}}_e^i$  is the resultant of the external moments acting on the body defined in the body coordinate system.

### 1.3 Installing ATTIF<sup>1</sup>

ATTIF is included in the installation of the general purpose multibody dynamics simulation software SIGMA/SAMS. Therefore, to use ATTIF, only the installation of SIGMA/SAMS necessary. There is no need to install ATTIF independent of SIGMA/SAMS. For instructions on how to install SIGMA/SAMS, please refer to the SIGMA/SAMS help manual.

---

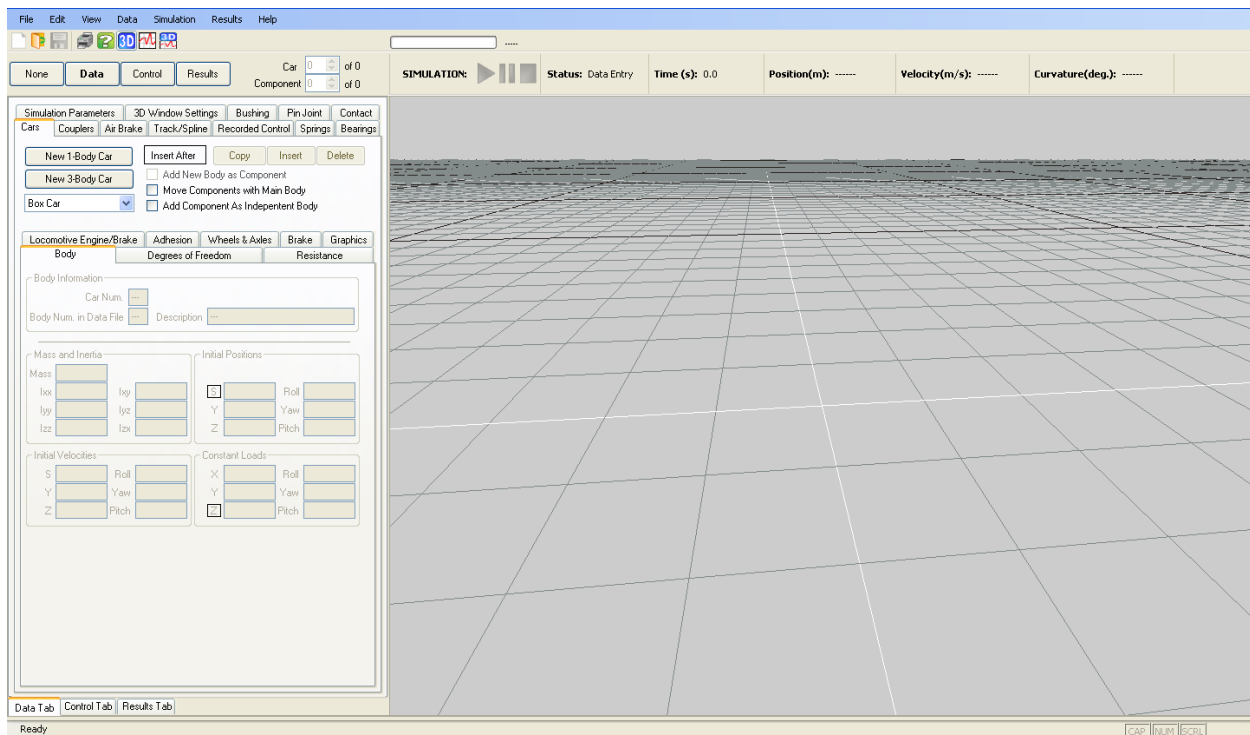
<sup>1</sup> Computational Dynamics, Inc. maintains and continues the development of ATTIF. If you have any questions, concerns, or are having any difficulty using ATTIF, please contact the administrative offices by phone at 630.750.5991 or by email at [cdi@computational-dynamics.com](mailto:cdi@computational-dynamics.com).

## 2. GETTING STARTED

This chapter provides a brief preface of the ATTIF program for the user to become familiarized with the application's interface. More detailed explanations of each interface option can be found in the later sections of this manual.

### 2.1 Introduction to the ATTIF Interface

Upon running the *ATTIF2000.exe* file from the ATTIF directory, located in the folder C:\Sams2000\Applications\ATTIF2000, Fig. 2.1 will appear on the computer screen. This is the main window of the ATTIF interface, and it is from here that model features can be easily created using each respective interface option.



**Figure 2.1 – ATTIF Main Window**

The ATTIF interface is organized into a few basic sections to simplify the process of creating and analyzing simulation models. Fig. 2.2 displays the main ATTIF window with marked sections of the interface.

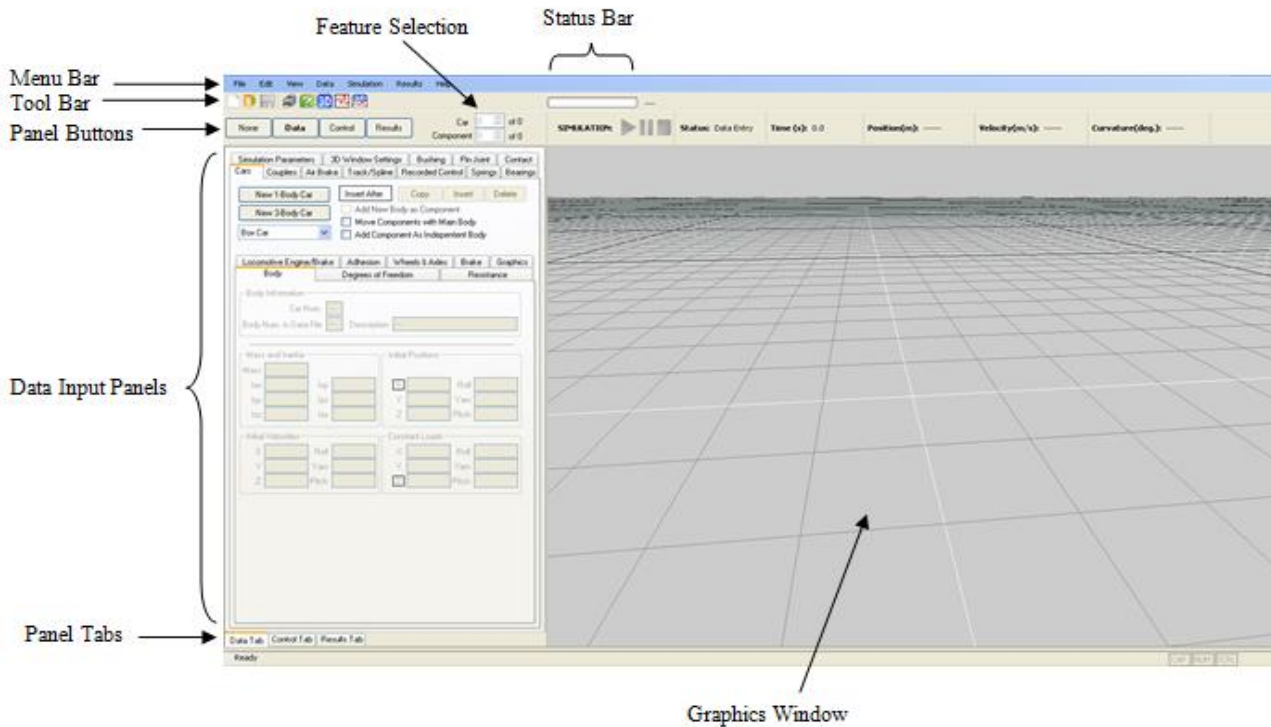


Fig 2.2 – ATTIF Interface Main Window Sections

## 2.2 Main Menus of the Interface

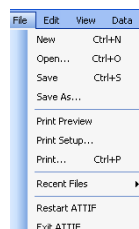
This part of the manual lists the features and/or capabilities of each menu of the graphical user interface.

### 2.2.1 Menu Bar

The menu bar includes the basic file options that are found on most common computer programs.

#### 2.2.1.1 File Dropdown Menu

With the *File* button a dropdown menu, Fig. 2.3, will appear and the user may:





### Figure 2.3 – File Dropdown Menu

1) Create and open a new file: *File* → *New*

This creates a new file with the default name *AttifModel.dat* in the ATTIF directory folder and opens it in the ATTIF interface. The Appendix contains an example data file for reference.

2) Open a saved file: *File* → *Open...*

This option allows the user to select a compatible file to be loaded into ATTIF. After selection, ATTIF immediately reads the file data into the interface. Fig. 2.4 shows the data reading status window that will appear when a previously created file is opened. This window will display the data that was successfully loaded and any errors it encountered while reading the data. If errors are found, then the file may need to be edited using a basic word editing software such as Notepad. Editing the data files in this way will be discussed in detail in a later section. From the Data Reading Status Window, the *Do Not Show Data Reading Status After Successful Data File Readings* box can be checked so that this window no longer appears after a file is successfully opened and read into the ATTIF interface.

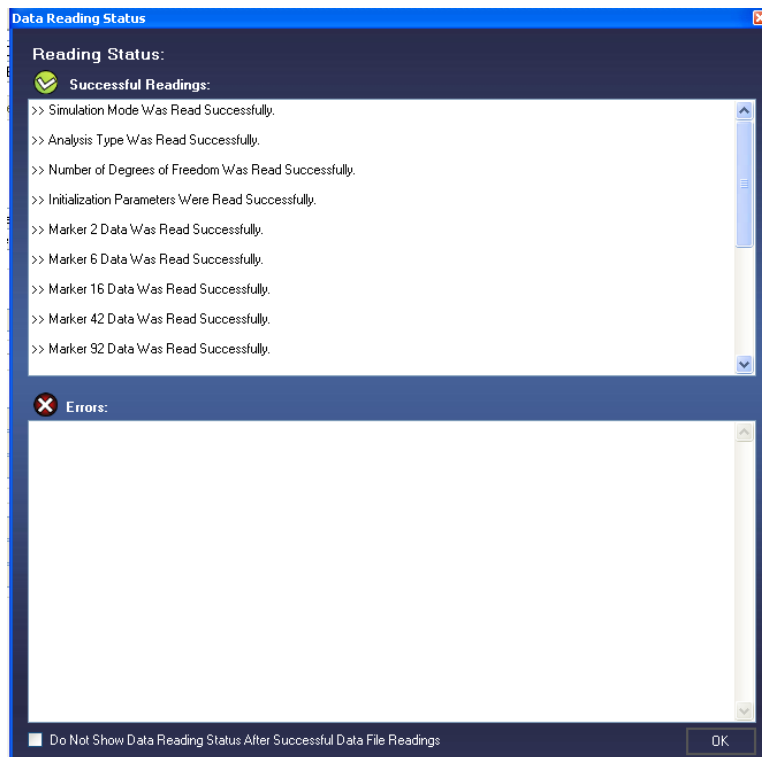


Fig 2.4 – Data Reading Status Window

3) Save file: *File* → *Save*

Saves the file with the current file name to the same directory it was opened from. THIS WILL OVERWRITE THE PREVIOUS VERSION OF THE FILE. If a new file was created and this is the first time the *Save* button is selected from the *File* dropdown menu, the user will be prompted to browse for an appropriate directory to save the file to.

4) Save file as: *File* → *Save As...*

Prompts the user to select a directory and new file name to save the currently opened file as.

5) Display print preview of graphics window: *File* → *Print Preview*

Opens the ATTIF Main Window as a view of what the graphics window will look like when printed. A print option and some other printing options are located on the top command bar in this window. To return to the ATTIF Main Window, select the *Close* button.

6) Display print options: *File* → *Print Setup...*

Opens a small window with paper, orientation, and margin printing options.

7) Print the graphics window: *File* → *Print...*

Prints the graphics window to the default printer.

8) Open and read recently opened files: *File* → *Recent Files*

Clicking or moving the mouse over this button will cause a dropdown menu to appear to the right, displaying the locations of the four most recently opened files. Selecting one of these files will open and load that file. A prompt window may open asking if the user would like to save the changes of the current file before loading one of the recently opened files.

10) Restart the ATTIF application: *File* → *Restart ATTIF*

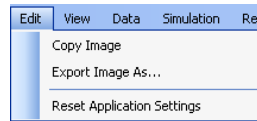
Shuts down and restarts ATTIF. A prompt window may open asking if the user would like to save the changes of the current file before restarting. Upon restarting, ATTIF will open at the Main Window. Restarting is required after each simulation of models that include detailed contact.

11) Exit the ATTIF application: *File* → *Exit ATTIF*

Shuts down ATTIF. A prompt window will open asking if the user would like to save the changes of the current file before exiting.

### 2.2.1.2 Edit Dropdown Menu

With the *Edit* button a dropdown menu, Fig 2.5, will appear and the user may:



**Figure 2.5 - Edit Dropdown Menu**

1) Copy graphics window: *Edit* → *Copy Image*

Attaches a screenshot of the current graphics window to the clipboard. Holding down the left mouse button while the cursor is on the graphics window and dragging will rotate the camera angle of the graphics window. Release the left mouse button at the desired view.

2) Export image of graphics window: *Edit* → *Export Image As...*

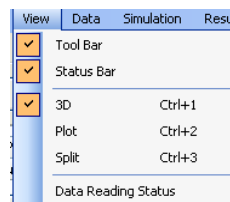
Opens a window that prompts the user to select a location, file name, and file type to save an image file of the current graphics window.

3) Reset ATTIF application settings: *Edit* → *Reset Application Settings*

Resets all changed application settings back to their default values.

### 2.2.1.3 View Dropdown Menu

With the *View* button a dropdown menu, Fig. 2.6, will appear and the user may:



**Figure 2.6 - View Dropdown Menu**

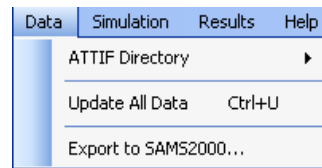
1) Select interface view by checking/un-checking desired options. Checking *Tool Bar* will show the Tool Bar, un-checking will hide it. Checking *Status Bar* will

show the Status Bar, un-checking will hide it. Checking *3D* will show the graphics window. Checking *Plot* will un-check the graphics window and display the selected results plot in place of the graphics window. Checking *Split* will display the selected results plot on the bottom half of the graphics window with the 3D graphics in the top half.

2) Open the Data Reading Status Window by selecting *Data Reading Status*. Here the *Do Not Show Data Reading Status After Successful Data File Readings* box can be checked or un-checked depending on user preference.

#### 2.2.1.4 Data Dropdown Menu

With the *Data* button a dropdown menu, Fig. 2.7, will appear and the user may:

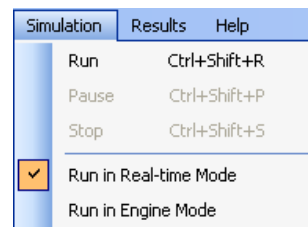


**Figure 2.7** - Data Dropdown Menu

- 1) Open a window of the ATTIF directory: *Data* → *ATTIF Directory* → *Open*
- 2) Update all data in the interface panels: *Data* → *Update All Data*
- 3) Export the open file to SAMS2000: *Data* → *Export to SAMS2000...*

#### 2.2.1.5 Simulation Dropdown Menu

With the *Simulation* button a dropdown menu, Fig. 2.8, will appear and the user may:



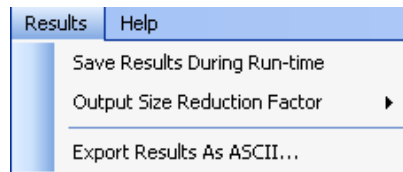
**Figure 2.8** - Simulation Dropdown Menu

- 1) Run the currently opened file: *Simulation* → *Run*

- 2) Pause the running simulation: *Simulation* → *Pause*
- 3) Stop the running simulation: *Simulation* → *Stop*
- 4) Check *Run in Real-time mode* (recommended) for the graphics window to display the results as soon as the program finds the results data for each time interval. Check *Run in Engine Mode* for the graphics window to display the results in the time frame of the simulation (i.e. if it takes the train model 10 minutes to travel the length of the loaded track, then the graphics display will be 10 minutes long, and the animation is not enabled with that option ).

#### 2.2.1.6 Results Dropdown Menu

With the *Results* button a dropdown menu will appear, Fig. 2.9, and the user may:



**Figure 2.9** – Results Dropdown Menu

- 1) Save results during run-time: *Results* → *Save Results During Run-time*

This saves the results as they are found during the run-time of the simulation for each time interval.

- 2) Reduce the output size: *Results* → *Output Size Reduction Factor*

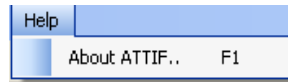
Opens a text box to enter a value for the size reduction factor of the output file. This simply skips the writing of a certain portion of data points to save space because the output files may become very large (>10MB) for some detailed models. The default value is 1, which writes all data points for each time step.

- 3) Export the simulation results as an ASCII file: *Results* → *Export Results as ASCII...*

After ending a simulation, selecting this option will open a window prompting the user to select a name and destination folder to save the results files to. It will save the results file in ASCII format and with the default name AttifResults.txt if no new name is entered.

### 2.2.1.7 Help Dropdown Menu

With the Help button a dropdown menu, Fig. 2.10, will appear and the user may:




**Figure 2.10** – Help Dropdown Menu

1) View ATTIF application information: *Help* → *About ATTIF...*


Opens a window displaying the currently installed version of ATTIF and a brief description of ATTIF's purpose.

### 2.2.2 Tool Bar

The Tool Bar is a command ribbon below the menu bar that includes a few quick-select buttons:

1) Create new file button - 

Creates a new file and loads it into ATTIF interface. A prompt will appear asking user to save current file if one is open and changes have been made after a previous save.

2) Open file button - 

Opens directory browser window to select a file to open and load into the interface. A prompt will appear asking user to save current file if one is open and changes have been made after a previous save.

3) Save button - 


Saves file. **THIS WILL OVERWRITE THE PREVIOUS VERSION OF THE FILE.**

4) Print button - 

Sends image of the 3D graphic display to the printer.

5) Help button - 


Opens the Help window which displays the application version and ATTIF description in

6) 3D display button - 

Displays only the 3D graphics of the model in the Graphics Window of the interface.

7) Results plot button - 

Displays only the selected results plot from the Results Tab in the Graphics Window.

8) Split screen button - 

Displays both the model 3D graphics and the results plot in the Graphics Window.

### 2.2.3 Panel Buttons



**Figure 2.11** – The Panel Buttons

The Panel Buttons, Fig. 2.11, are used to switch between the different tabs utilized by the user-interface.

1) *None* button – Removes the Data Entry Panel from the display. Whichever display option is selected will be transposed to fit the entire length of the screen.

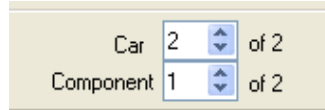
2) *Data* button – Shows the Data Tab in the Data Entry Panel on the left-hand side of the screen. The Data Tab is used to build models and will be explained in a later section.

3) *Control* button – Shows the Control Tab in the Data Entry Panel. The Control Tab is used to change the setting of a locomotive's tractive effort engines, break pipes, and coupler activation. It will be fully explained in a later section.

4) *Results* button – Shows the Results Tab in the Data Entry Panel. The Results Tab is used to display selected data on the results plot. It will be explained in detail in a later section of this manual.

### 2.2.4 Feature Selection

Model bodies and components can be selected through the use of the Feature Selection boxes, Fig. 2.12.



**Figure 2.12** – Feature Selection boxes

The cars and components created in the file can be selected for editing by either scrolling through the features with the arrow buttons or by typing in the number of the desired feature in the boxes. These two numbers (car number and component number) also refer to the model feature that the Graphics Window is centered on.

### 2.2.5 Status Bar

The Status Bar shows the percentage of completion of the loaded file while it is running. Directly below the Status Bar, other useful information is also displayed. The simulation time, position of the selected feature (from Feature Selection boxes) along the s-axis of the track, velocity of the selected feature along the s-axis, and curvature of the track at the point of the selected feature are all conveniently displayed for quick reference during simulations. The simulation may also be started, paused, or stopped using their respective buttons, Fig. 2.13, located directly below the Status Bar.



**Figure 2.13** – Status Bar and quick reference data

### 2.2.6 Data Input Panels

The Data Input Panel is used to build, define, constrain, control, import data, and select results. The panel can be switched between Data, Control, and Results using the Panel Buttons. The *Data* Panel contains many tabs which are organized into categories for the simple modeling of any necessary features. The *Control* Panel and *Results* Panel do not have any tabs. These three panels will be explained in greater detail in the next chapter.

### 2.2.7 Panel Tabs

The Panel Tabs, Fig. 2.14, may be used as an alternative to the previously mentioned Panel Buttons. Selection of a Panel Tab will display its respective Data Panel in the Data Input Panel section of the interface.





**Figure 2.14** – Panel Tabs

### 2.2.8 Graphics Window

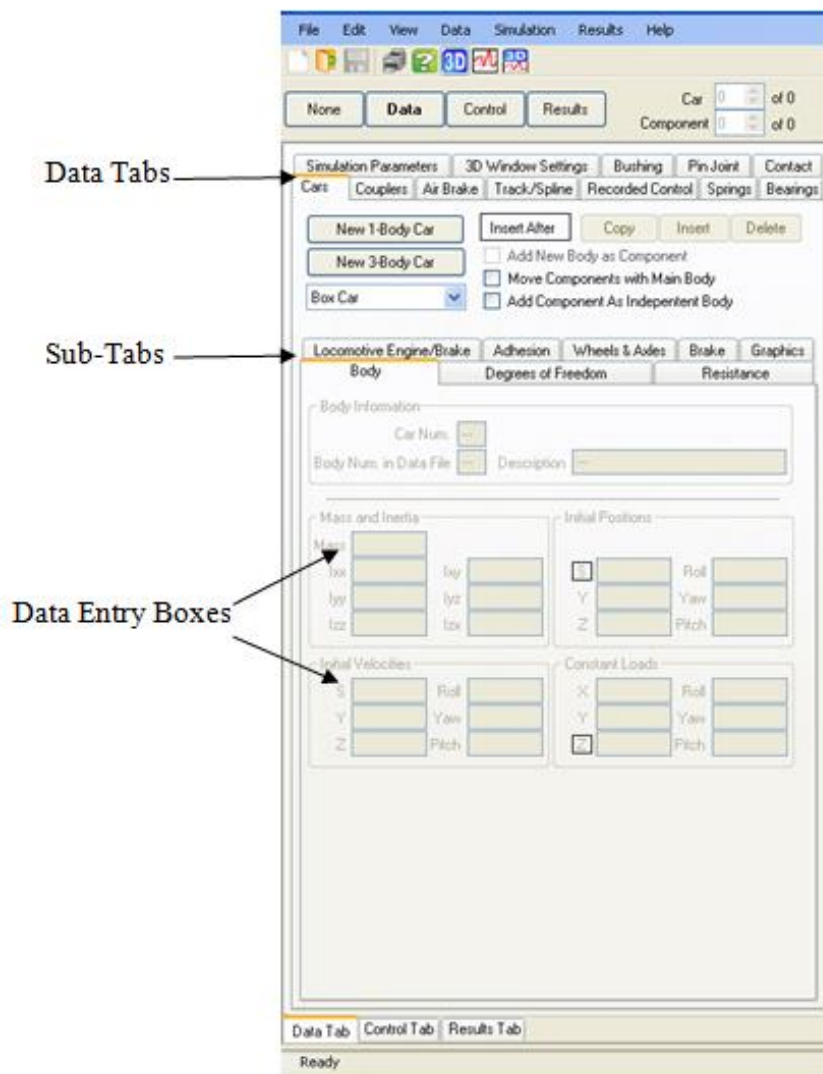
One of the most useful features of any simulation software is the ability to display the model on screen to provide a visual understanding of what is happening. This feature is extremely helpful in building models and fixing any present errors. Holding down the left mouse button while the cursor is on the Graphics Window and dragging will rotate the camera angle of the Graphics Window. Release the left mouse button at the desired view. Remember that the Graphics Window will always be centered on the feature indicated in the Feature Selection boxes. The center of the Graphics Window (0,0) can be located at the intersection of the two white axes (x-axis and y-axis). Gray grid lines are displayed every ten meters along the s-axis and y-axis.

### 3. LONGITUDINAL TRAIN MODELING IN ATTIF

This chapter describes the input data required to create a model in ATTIF. A model is defined by a collection of bodies, components, kinematic constraints, force elements, and other sets of data segments that describe the system inertia, materials, and dimensions. This section gives a detailed description for all the standard data for elements that are parts of the ATTIF library.

#### 3.1 Data Entry

ATTIF includes a simple user-interface that allows model data to be entered into prescribed locations amongst the organized tabs, see Fig. 3.1. This section will explain the details of each of the Data Tabs.

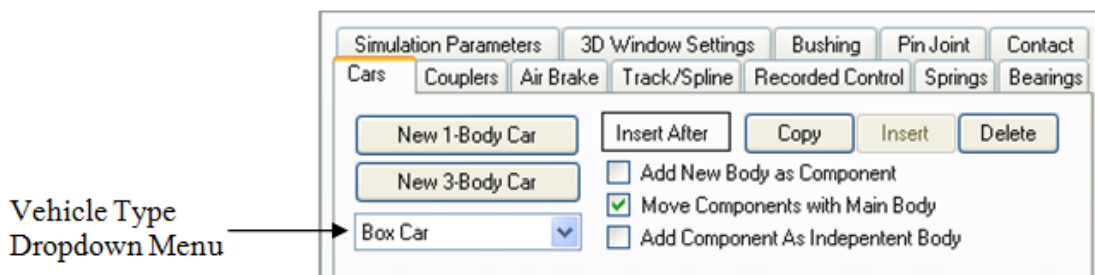


**Figure 3.1** – Data Panel displaying the Cars Tab. Data Tabs and Data Entry Boxes are marked.

### 3.1.1 Cars Tab

ATTIF allows each body to have from one to six degrees of freedom by the user, allowing for simplified train models when the interest is only on the entirety of the train consist. Alternatively, the user may also define fewer but more detailed bodies as articulated cars to analyze derailment and accident scenarios at a closer level, if desired. The combination of these two methods results in a greater knowledge of the interaction forces of long trains.

Upon opening the ATTIF program and creating a new file, the Cars Tab will be displayed in the Data Entry Panel, Fig. 3.1. This Tab includes the necessary input points for creating each railcar. Directly beneath the marker for the Cars Tab are a few important buttons and boxes, Fig. 3.2.



**Figure 3.2** – Cars Tab primary buttons and check boxes

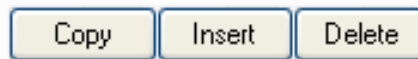
1) *New 1-Body Car* Button– Creates a new single body vehicle and displays it in the graphics window. Use this button for a very simplified car model, where the car body, bogies, and wheelsets are all considered as part of one body by the program and are not treated independently in the simulation.

2) *New 3-Body Car* Button – Creates a new triple body vehicle and displays it in the graphics window. Use this button for a car that treats the car body and the two trucks (bogies) as independent components. The individual components of the body can be selected with the Feature Selection Component box which, by default, assigns the number 0 to the car body, 1 to the rear truck, and 2 to the lead truck.

3) *Vehicle Type Dropdown Menu* – Use this menu to select which type of rail vehicle, or component you would like to model. Vehicles include: Box Car, Flat Car, Locomotive, Tank car, and Hopper Car. Note that the default parameters of these vehicles do not change for different selections, with the exception of the Locomotive. The vehicle's graphics displayed in the Graphics Window will be the only difference. This menu's Components include: Truck, Wheel Set, and Frame. Note that these components may only be added to the model as Components, so the *New 1-Body Car* Button must be selected.

4) *Insert After/Insert Before* Toggle Button – This button allows bodies and components to be added in to different fashions. If *Insert After* is displayed, then selecting one of the *New Car* Buttons will insert the new desired body or component after the currently selected car/component in the Feature Selection boxes. Click *Insert After* to toggle to *Insert Before* and vice versa. *Insert Before* adds the new feature before the selected body/component in the Feature Selection boxes. Note that “*After*” and “*Before*” only refer to the assigned car number and component number of the new feature and not the physical location of the feature within the model. By default the new feature’s location will be at the origin and the location must be changed in the Body Sub-Tab.

5) To the right of the *Insert After/Insert Before* Toggle Button are the *Copy*, *Insert*, and *Delete* Buttons, Fig 3.3. The *Copy* Button is useful for copying the selected Car (this will copy all of the car’s parameters from the Sub-Tabs). After the *Copy* Button has been pressed the *Insert* Button will become available and the user may select it to insert the copied Car into the model. The *Delete* Button will remove the selected Car or Component from the model and remove its displayed graphics from the Graphics Window.



**Figure 3.3** – *Copy, Insert, Delete* Buttons from the Cars Tab

6) *Add New Body as Component* Check Box – Checking this box will add a selected component (Truck, Wheel Set, or Frame) from the Vehicle Type Dropdown Menu as a component of the current Car. Remember that the *Insert After/Insert Before* Toggle Button still applies.

7) *Move Components with Main Body* Check Box – This box is checked by default and is useful when placing new Cars in your model. The Initial Position of the components will remain in their locations relative to the main body when a new location is entered for the main body of the car (component 0).

8) *Add Component as Independent Body* Check Box – Checking this box will assign a newly added component its own Car number. Its component number will be 0.

#### 3.1.1.1 Body Sub-Tab

ATTIF allows each component (body) of a car to be customized to the user’s needs. The Body Sub-Tab, Fig 3.4, within the Data Tab includes the main physical attributes of the component.

**Figure 3.4 – Body Sub-Tab**

**Body Information:** This section includes the Car number of the selected component, the assigned body number of the selected component in the data file, and a description of the component type.

**Mass and Inertia:** This section is used to input the mass and mass moment of inertia of the body.

- |         |  |
|---------|--|
| 1. Mass | The mass of the body (kg)  |
| 2. Ixx  | The mass moment of inertia about x-axis ( $\text{kg}\cdot\text{m}^2$ )       |
| 3. Iyy  | The mass moment of inertia about y-axis ( $\text{kg}\cdot\text{m}^2$ )       |
| 4. Izz  | The mass moment of inertia about z-axis ( $\text{kg}\cdot\text{m}^2$ )       |
| 5. Ixy  | The product of inertia of x-axis about y-axis ( $\text{kg}\cdot\text{m}^2$ ) |
| 6. Iyz  | The product of inertia of y-axis about z-axis ( $\text{kg}\cdot\text{m}^2$ ) |
| 7. Izx  | The product of inertia of z-axis about x-axis ( $\text{kg}\cdot\text{m}^2$ ) |

**Initial Positions:** This section is used to input the initial coordinates that define the initial conditions trajectory coordinates at the beginning of the simulation of the body.

- |          |   |
|----------|---|
| 1. S     | The initial global s-coordinate of the center of mass (m) |
| 2. Y     | The initial global y-coordinate of the center of mass (m) |
| 3. Z     | The initial global z-coordinate of the center of mass (m) |
| 4. Roll  | The initial rotation angle about the x-axis (radians)     |
| 5. Yaw   | The initial rotation angle about the z-axis (radians)     |
| 6. Pitch | The initial rotation angle about the y-axis (radians)     |

**Initial Velocities:** This section is used to input the initial velocities at the beginning of the simulation of the body.

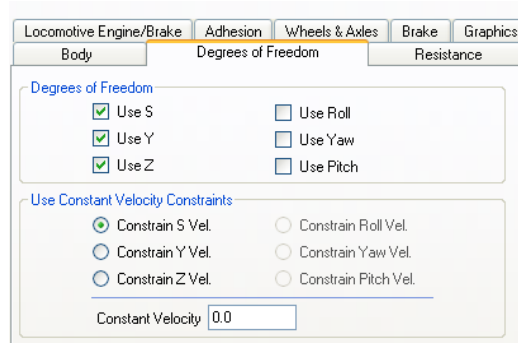
1. S The initial global velocity of the center of mass along the x-axis (m/sec)
2. Y The initial global velocity of the center of mass along the y-axis (m/sec)
3. Z The initial global velocity of the center of mass along the z-axis (m/sec)
4. Roll The initial angular velocity about the x-axis (radians/sec)
5. Yaw The initial angular velocity about the z-axis (radians/sec)
6. Pitch The initial angular velocity about the y-axis (radians/sec)

**Constant Loads:** This section is used to input the constant forces acting on the body. These forces must be defined in the global coordinate system. These constant forces can be used to represent gravity and load forces.

1. X The constant global force acting on the body in the x direction (N)
2. Y The constant global force acting on the body in the y direction (N)
3. Z The constant global force acting on the body in the z direction (N)
4. Roll The constant torque acting on the body about the x axis (N·m)
5. Yaw The constant torque acting on the body about the z axis (N·m)
6. Pitch The constant torque acting on the body about the y axis (N·m)

### 3.1.1.2 Degrees of Freedom Sub-Tab

In ATTIF the Degrees of Freedom (DOF) of a body can be added or removed with ease. The Degrees of Freedom Sub-Tab, Fig. 3.5, located with the Data Tab allows the six DOFs of each body to be included in or removed from the simulation. This feature permits the user to more easily test certain features of their model, while cutting down on computation time.



**Figure 3.5** – Degrees of Freedom Sub-Tab

**Degrees of Freedom:** Check/Un-check each box to add/remove DOF for the selected currently body.

**User Constant Velocity Constraints:** Select/De-Select each circle to add/remove a velocity constraint in the desired direction. These velocities will remain constant for the selected body for the duration of the simulation. For each DOF box checked, a Constant Velocity Constraint may be chosen for that DOF and the desired velocity entered in the box at the bottom of the Sub-Tab.

### 3.1.1.3 Resistance Sub-Tab

Air resistance is an important consideration when simulating train dynamics over long distances. ATTIF includes resistance formulations to include these forces as part of the simulation. The resistance force models include: rolling resistance, curve, grade resistance and aerodynamic resistance. The rolling resistance is dependent on the vehicle weight, number of axles per vehicle, and the vehicle speed. The physical resistance is effective through the journal and flange of each axle on the railcar. Curve resistance is comparatively similar to rolling resistance in that the motion of the axels experience forces acting against them as they move along a curved track segment and are dependent on vehicle weight, track curvature and resistance. Lastly, the aerodynamic resistance model impedes the motion of the railcar as it moves through the air utilizing the Davis Equation. The Resistance Sub-Tab, Fig. 3.6, lets the user modify the aerodynamic properties of each body.

Locomotive Engine/Brake		Adhesion		Wheels & Axles		Brake		Graphics	
Body			Degrees of Freedom			Resistance			
<input checked="" type="checkbox"/> Use Resistance Model									
Aerodynamics Properties									
Car Location		Middle Car							
		Front				Rear			
X Position of Area Center		6.0				-6.0			
Y Position of Area Center		0.0				0.0			
Z Position of Area Center		-2.5				-2.5			
Cross Section Area		10.2				10.2			

**Figure 3.6 – Resistance Sub-Tab**

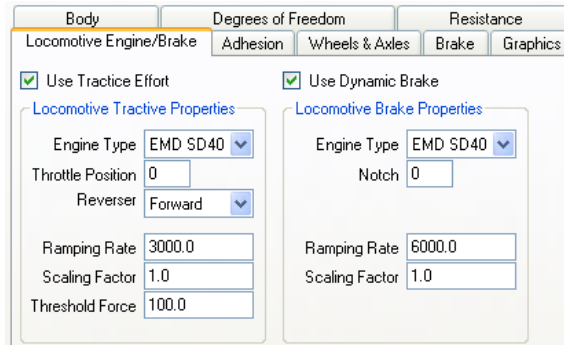
**Aerodynamic Properties:** Check/Un-Check *Use Resistance Model* to include the aerodynamic resistance formulation for the selected body. Choose the body's car location within the train consist by selecting a position from the Car Location dropdown menu. The X, Y, and Z position (m) of the Area Center of the body may be specified in their respective data boxes for the front and rear of the body. The cross sectional area (m<sup>2</sup>) may also be specified for the front and rear of the body in the last row data boxes.

#### 3.1.1.4 Locomotive Engine/Brake Sub-Tab

The tractive effort force is the propelling force produced by the locomotive that drives the train. The force is generated through friction between the wheels of a locomotive and the rails of the track. ATTIF includes a locomotive model based off of the Electro-Motive Diesel SD-40-2 locomotive specifications in the vehicle library. This type of locomotive develops the tractive effort forces by combusting diesel fuel to power electric drive motors. Electric propulsion locomotives also utilize dynamic brakes by using the tractive effort motors in the locomotive to create a torque on the wheels that opposes the motion of the train. ATTIF models this element of the locomotive similarly to the tractive effort, with eight different control positions. When the dynamic brakes are applied the kinetic energy of the train is converted into electrical energy, which is then dissipated by resistor banks in the locomotives.

For each Locomotive in the model, the Locomotive Engine/Brake Sub-Tab, Fig. 3.7, will be available. Here the user may change the default parameters of the selected Locomotive.





**Figure 3.7** – Locomotive Engine/Brake Sub-Tab

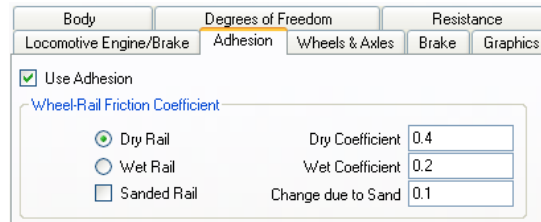
**Locomotive Tractive Properties:** Check/Un-Check *Use Tractive Effort* to enable/disable the locomotive's use of its tractive effort engines which provide the propulsion force of the train. The locomotives in ATTIF are based on the operating characteristics of the Electro-Motive Diesel SD-40-2 locomotive. In the *Engine Type* Dropdown Menu this locomotive can be selected (the only available choice at this point in development). The throttle position (0-8) of the selected locomotive's tractive effort engines can be constrained by entering a value from zero through eight into the *Throttle Position* data box. Three gearing position are available: Forward, Neutral, and Reverse. The position can be chosen in the *Reverser* Dropdown Menu. Ramping Rate, Scaling Factor, and Threshold Force of the locomotive may also be edited from their default by entering any positive value in their respective data entry boxes.

**Locomotive Brake Properties:** Check/Un-Check *Use Dynamic Brake* to enable/disable the locomotive's use of its dynamic brake. Again, the engine type may be selected. The brake position (0-256) may be chosen for the selected locomotive by entering a value into the *Notch* data box. This will constrain the brake to that position for the duration of the simulation. The Ramping Rate and Scaling Factor can also be assigned using their respective data entry boxes.

### 3.1.1.5 Adhesion Sub-Tab

Another important aspect of railroad dynamic studies and research is Wheel-Rail Adhesion. ATTIF allows the user to: define wheel and rail surface geometry for railroad applications, find the wheel/rail contacts and to specify the method in which the contact forces should be calculated. There are several three-dimensional formulations implemented in ATTIF that can be used to determine the wheel/rail contact points online. The wheel and rail surface profiles can be defined in ATTIF using a spline function representation. The Adhesion Sub-Tab,

Fig. 3.8, allows the user to adjust the friction coefficients between the Wheel Set and rails.

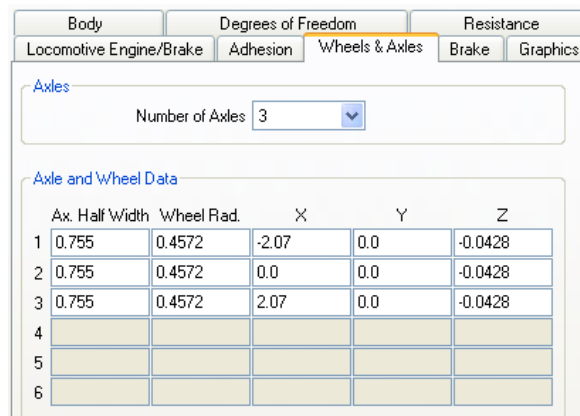


**Figure 3.8** – Adhesion Sub-Tab

**Wheel-Rail Friction Coefficient:** Check/Un-Check *Use Adhesion* to enable/disable the inclusion of the wheel-rail friction coefficient in the software’s dynamic analysis algorithms. Dry, wet, and sanded rails may be selected and their respective coefficients entered in their corresponding data boxes. The *Sanded Rail* may be checked for either *Dry Rail* or *Wet Rail*. Sand is commonly carried on locomotives and poured along the tracks to help add traction in bad conditions.

### 3.1.1.6 Wheels & Axels Sub-Tab

The number of axels and its characteristics can be edited from their default values through the *Wheels & Axels* Sub-Tab, Fig. 3.9, within the *Cars* Tab of the *Data* Panel.



**Figure 3.9** – Wheels & Axels Sub-Tab

**Axles:** By clicking the arrow a dropdown menus will appear and the user may select the Number of Axels for the selected Car or Component. A value of 2 or 3 should be chosen for selected Trucks.

**Axle and Wheel Data:** For each axle of the selected Car or Component, certain parameters may be adjusted in the model. The Axle Half Width (m), Wheel

Radius (m), and X, Y, and Z locations (m, relative to main body) can be assigned by entering values in their respective data boxes.

### 3.1.1.7 Brake Sub-Tab

Each Car's Air Brake Car Control Unit (CCU) and specific brake model may be altered within the *Brake* Sub-Tab, Fig. 3.10. This feature is used to test a brake model's effectiveness and then to compare with other brake models to optimize performance benefits.

The screenshot shows the 'Brake' sub-tab of a software interface. It is divided into several sections:

- Use Air Brake M130:** A checked checkbox and a text box for 'Air Brake M130 Number' with the value '1'.
- Use Air Brake M133:** A checked checkbox.
- Car Control Unit Data:** A grid of input fields:
 

Brake M133 Number	1	Brake Cyl. Area	0.05067
Auxiliary Res. Volume	0.0454	Brake Cyl. Volume	0.004839
Emergency Res. Volume	0.060550	Friction Coef.	0.35
Pressure Difference	10342.0	Emergency Pressure Rate	-200000.0
Relative Branch Pipe Pos.	0.0	Relative Pipe End Pos.	0.0
- Connecting Areas:** A grid of input fields:
 

Brake Pipe-Auxiliary Res.	2.011E-06	Brake Pipe-Emerg. Res.	1.096E-06
Brake Pipe-Atmosphere	1.267E-05	Brake Cyl.-Auxiliary Res.	2.0645E-0
Brake Cyl.-Emerg. Res.	4.129E-06	Brake Cyl.-Atmosphere	4.458E-06
- Brake Rigging:** Input fields for 'Ratio' (10.0) and 'Efficiency' (0.65).
- Brake Cylinder Spring:** Input fields for 'Stiffness' (14593.31) and 'Maximum Displacement' (0.2032).

**Figure 3.10** – Brake Sub-Tab

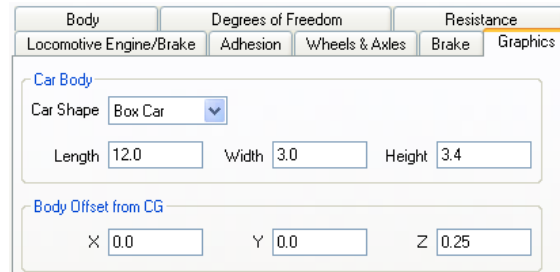
**Brake Model:** If a Simple Air Brake is created in the model through the *Simple Air Brake* Sub-Tab of the *Air Brake* Tab, then the Brake Model M130 Number selection becomes available in the *Brake* Sub-Tab of the *Cars* Tab. Check/Un-Check the *Use Air Brake M130* box to enable/disable the inclusion of the M130 air brake in the simulation. Use the entry box to assign a marker number to the selected Car's simple air brake.

**Car Control Unit Data:** As with the Simple Air Brake, if a Detailed Air Brake is created in the model through the *Detailed Air Brake* Sub-Tab of the *Air Brake* Tab, then the Car Control Unit Data section becomes available in the *Brake* Sub-Tab of the *Cars* Tab. This section includes many inputs that determine the parameter values of the Detailed Brake CCU. All parameters are in the standard International System of Units (SI) units.

### 3.1.1.8 Graphics Sub-Tab

An important part of dynamic simulations and a valuable feature of ATTIF is the ability to graphically portray each body's kinematics within the model.

Visualization assists the user in constructing the model and helps make finding modeling errors more inherent. The *Graphics* Sub-Tab can be seen below in Fig. 3.11.



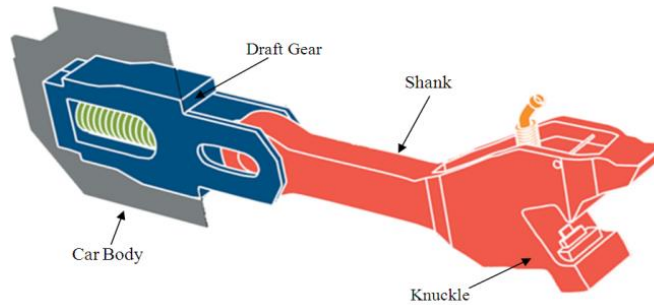
**Figure 3.11** – Graphics Sub-Tab

**Car Body:** The graphical representation of the Components in the Graphics Window can be selected using the *Car Shape* Dropdown Menu. However, only the main body of a car may be changed from its default graphic and measurements. The *Length* (m), *Width* (m), and *Height* (m) of the main body may also be entered.

**Body Offset from CG:** If the user wishes to adjust the location of the graphic of a body within the Graphics Window, then data values may be entered (m, positive or negative) to displace the body's center of gravity in the Graphics Window. Note that the body's true center of gravity in the Initial Positions section of the *Body* Sub-Tab in the *Cars* Tab will remain the same.

### 3.1.2 Couplers Tab

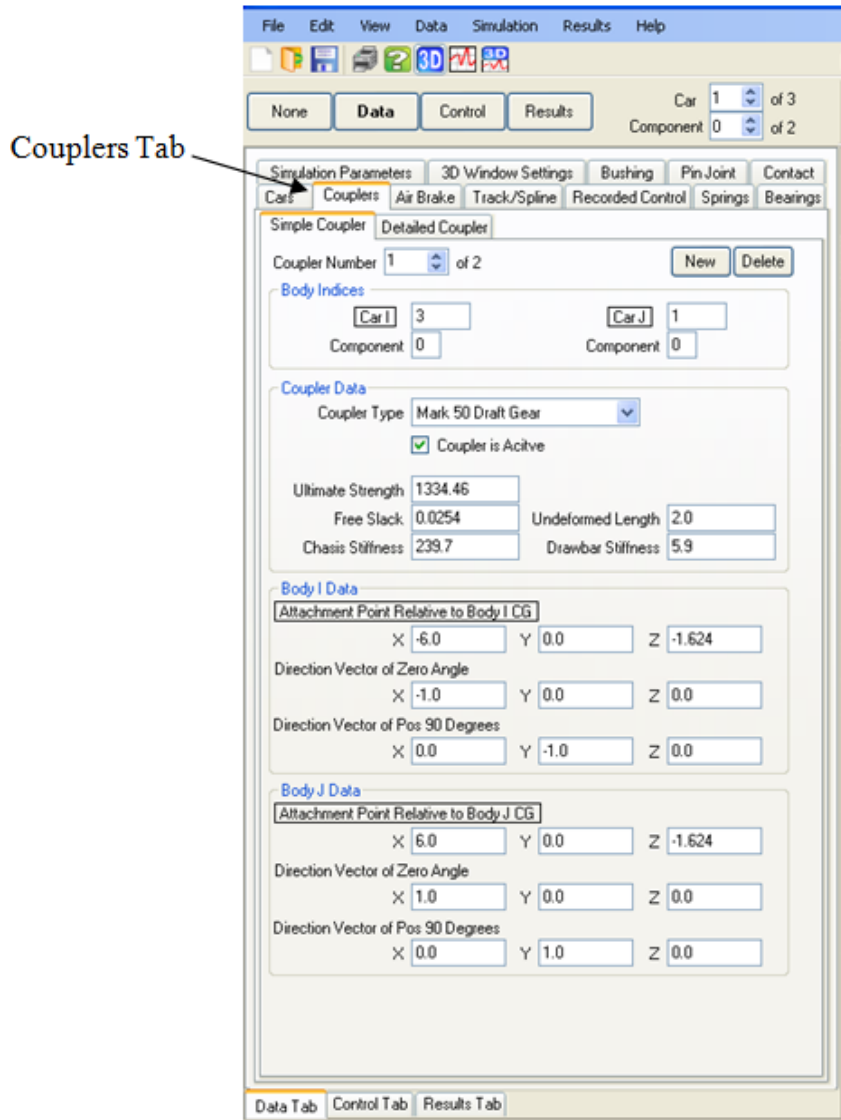
Linking multiple cars together in a train necessitates the use of coupler elements. Coupler elements that connect train cars have a significant effect on longitudinal train forces and can significantly influence the stability, derailments and accidents of railroad vehicle systems. It is known that longitudinal train forces during braking, traction, and curve negotiations heavily depend on the design of these couplers, their degrees of freedom, and their ability to absorb impact forces and dissipate energy. As shown in Fig. 3.12, the coupler element consists of a head and shank that can be connected to a flexible unit such as a draft gear or an end-of-car-cushioning (EOC) device which are attached to the car body.



**Figure 3.12 - Coupler Components**

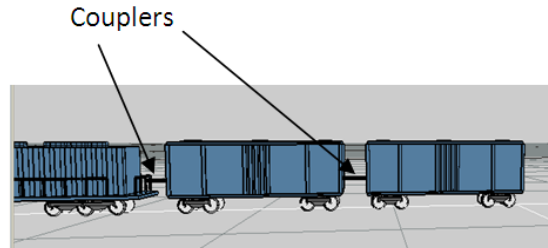
ATTIF has a new three-dimensional non-linear train car coupler model that takes into account the *geometric nonlinearity* due to the coupler and car body displacements. The proposed non-linear coupler model allows for arbitrary three-dimensional motion of the car bodies and captures kinematic degrees of freedom that are not captured using existing simpler models. The coupler kinematic equations are expressed in terms of the car body coordinates as well as the relative coordinates of the coupler with respect to the car body.

Couplers may be added wherever the user specifies in the train consist and be selected as either a draft gear or an end-of-car cushioning device (EOC), where the energy of the attached components are dissipated by dry friction or fluid damping, respectively. In the formulation used in ATTIF, the model of any particular draft gear is based on force-displacement relationships determined using empirical formulas. After creating vehicles in the *Cars* Tab, the user may then connect them together by making couplers in the *Couplers* Tab, Fig. 3.13.



**Figure 3.13** – *Couplers* Tab located by arrow. This figure displays the Simple Coupler Sub-Tab.

The user must first choose between a simple or detailed coupler, and then select its respective Sub-Tab. Detailed couplers allow the user to specify more thorough information into the *Body Data* sections for the coupler. To build a coupler the “New” button at the top right of the Sub-Tab must be clicked first before entering data. Once the coupler is created use the following sections of the Sub-Tab to define the newly created coupler. A coupler will appear as a small black rectangle in the Graphics Window, see Fig. 3.14 below.



**Figure 3.14** – Couplers in the Graphics Window

**Body Indices:** Enter the car and component numbers of the bodies that the coupler is linking.

**Coupler Data:** Select what type of coupler you would like in the *Coupler Type* Dropdown Menu. Couplers may also be made active/un-active by checking/un-checking the check box underneath the *Coupler Type* Dropdown Menu. Here some basic parameters (all in standard SI units) may be entered for the coupler.

**Body I Data:** ATTIF requires the location on first body (body  $i$ ) where the coupler is connected to be entered in this section. Also, the direction vectors must be entered, but the default values that appear can be used in most cases. If a detailed coupler was chosen, then ten more parameter values are needed for the coupler model and may be entered into their respective data entry boxes.

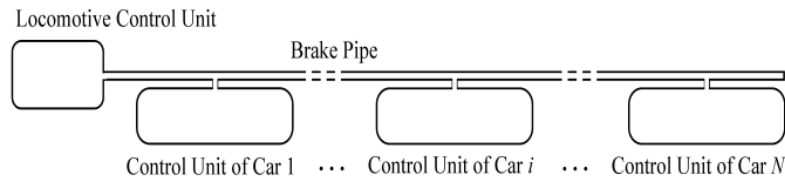
**Body J Data:** ATTIF requires the location on second body (body  $j$ ) where the coupler is connected to be entered in this section. Also, the direction vectors must be entered, but the default values that appear can be used in most cases. If a detailed coupler was chosen, then ten more parameter values are needed for the coupler model and may be entered into their respective data entry boxes.

**Shank Knuckle/Chassis Data:** This last section is only available in the *Detailed Coupler* Sub-Tab. Here six more parameters are required for the shank knuckle and chassis of the coupler.

### 3.1.3 Air Brake Tab

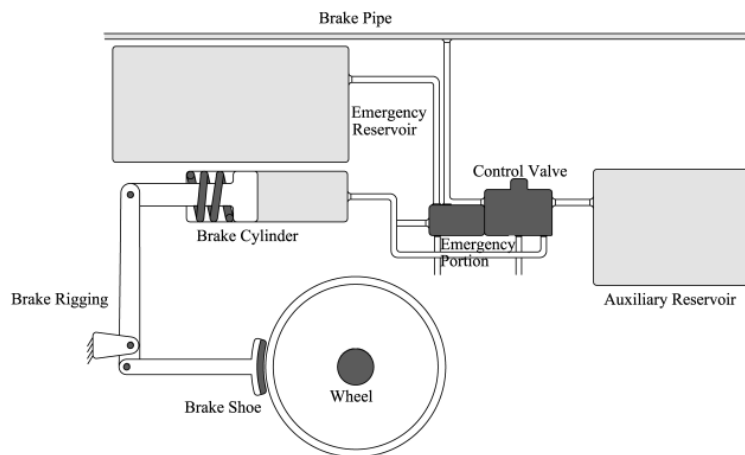
Much like the *Couplers* Tab, the *Air Brake* Tab, Fig. 3.18, allows the user to create either a simple or detailed air brake model. Whichever type is chosen will be effective for the entire train model. ATTIF integrates an air brake model with efficient train longitudinal force algorithms based on the trajectory coordinate formulations. The air brake model developed in ATTIF consists of the locomotive automatic brake valve, air brake pipe, and

car control unit (CCU) as shown in Fig. 3.15. Using the finite element method, the proposed air brake force model accounts for the effect of the air flow in long train pipes as well as the effect of leakage and branch pipe flows. This model can be used to study the dynamic behavior of the air flow in the train pipe and its effect on the longitudinal train forces during brake application and release.



**Figure 3.15 - Main air brake components**

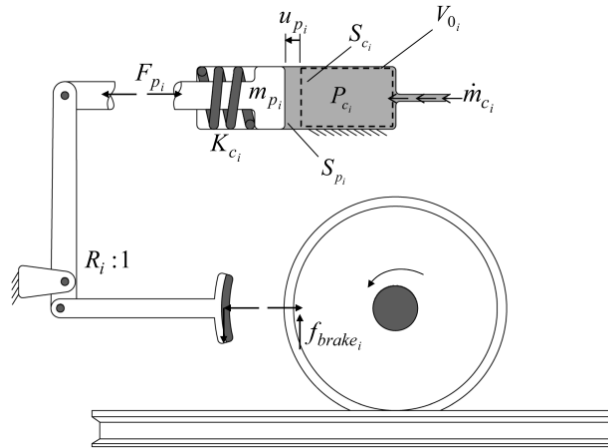
Detailed CCU as shown in Fig. 3.16 is considered. The coupling between the air brake, locomotive automatic brake valve, car control units, and train equations is established and used in ATTIF in the simulation of the nonlinear dynamics of long trains.



**Figure 3.16 - Car control unit components**

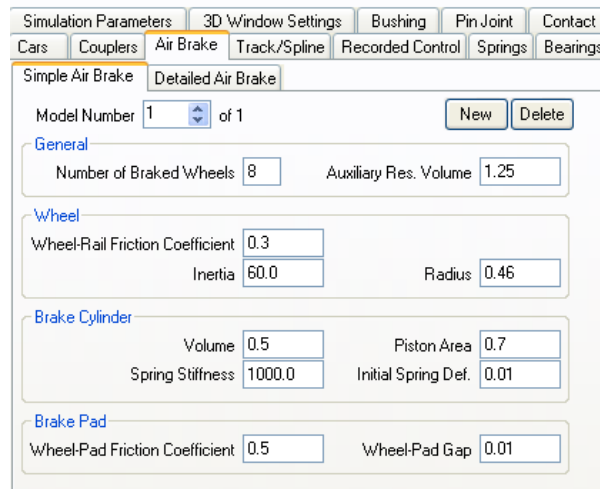
The car brake forces, Fig. 3.17, that depend on the locomotive automatic brake valve handle position and are applied to the wheels using the CCU located along the brake pipe enter into the formulation of the nonlinear train dynamic equations.





**Figure 3.17** - Brake force on a car wheel

Different computer simulation scenarios have been considered in order to investigate the effect of the air brake forces on the train longitudinal dynamics in the case of different braking modes.



**Figure 3.18** – Air Brake Tab displaying Simple Air Brake Sub-Tab

The user must first choose between a simple or detailed air brake, and then select its respective Sub-Tab. Detailed air brakes allow the user to specify more thorough information for the air brake. To build a air brake for the consist the “New” button at the top right of the Sub-Tab must be clicked first before entering data. Once the air brake is created use the following sections of the Sub-Tab to define the newly created coupler.

**General:** Define the number of braked wheels on each vehicle and the auxiliary reservoir volume of the air brake model.

**Wheel:** Enter data for wheel-rail friction coefficient, inertia and radius.

**Brake Cylinder:** Define the parameters for volume, spring stiffness, piston area and initial spring deformation into their respective data entry boxes.

**Brake Pad:** Define the wheel-pad friction coefficient and wheel-pad gap of the air brake model.

Information for the *Detailed Air Brake* Sub-Tab, Fig. 3.19, is much more extensive than for the simple air brake. This Sub-Tab allows the user to enter specific data for a particular industry air brake model. Default values will appear after the “New” button is clicked, and these values can be helpful if alternative values for certain parameters are not known.

Simulation Parameters | 3D Window Settings | Bushing | Pin Joint | Contact  
 Cars | Couplers | **Air Brake** | Track/Spline | Recorded Control | Springs | Bearings  
 Simple Air Brake | **Detailed Air Brake**

Model Number 1 of 1 [New] [Delete]

**General**  
 Main Reservoir Pressure: 1052829.4  
 Operating Pressure: 721853.15 Atmospheric Pressure: 101325.0  
 Brake Handle Position:  
 Recharge  Service  Emergency

**Brake Pipe Data**  
 Element Type: Linear Brake Pipe Area: 0.0008276  
 Number of Nodes: 45 Leakage: 0.0  
 Cut-off Valve Position:  
 Head End  Rear End

**Air Properties**  
 Viscosity: 1.95E-05 Temperature: 300.0  
 Gas Constant: 286.9  
 Friction Coefficients:  
 a1 (Laminar): 64.0 b1 (Laminar): -1.0  
 a2 (Transient): 0.000375 b2 (Transient): 0.58  
 a3 (Turbulent): 0.154 b3 (Turbulent): -0.1403

**26C Valve Properties**

Ve <sub>q</sub>	0.00360515	A12	0.0083613	A15	3.17E-05
A11	0.00010722	L12	28.16	L13	16.46
L11	28.78	K12	3.56	K13	1.77
K11	1.73	D14	0.0236	D16	0.0185
KD	5.78	×D	0.0010668	×I	0.000762
×S	0.00635	Aeq <sub>vs</sub>	2.9E-06	Aeq <sub>ve</sub>	1.45E-06
×E	0.004064	L21	5.0	K21	2.6476
A21	1.6E-05				

**Figure 3.19** – *Detailed Air Brake* Sub-Tab

### 3.1.4 Track/Spline Tab

A vital part of any train model is the track, and the *Track/Spline* Tab, Fig. 3.20, makes it simple to select and load a track file into the interface. Spline data can also be loaded for models which include wheel-rail contact.

The screenshot shows the 'Track/Spline' tab in the ATTIF software interface. At the top, there is a row of tabs: Simulation Parameters, 3D Window Settings, Bushing, Pin Joint, Contact, Cars, Couplers, Air Brake, Track/Spline (highlighted), Recorded Control, Springs, and Bearings. Below the tabs, the 'Track File' section is visible. It has a 'File Status' field with the text 'Track File Selected, Not Loaded'. Below this are two buttons: 'Open Track File' and 'Open Default Track File'. The 'File Path' field contains the text 'C:\Sams2000\Applications\ATTIF2000\SamsCrvt.dat'. Below the file path is a 'Load Track Data' button. Underneath is a 'Track Curve Number' input field with the value '1'. Below that is a checkbox labeled 'Spline Functions' which is currently unchecked. The 'Spline File' section is below. It has a 'Number of Spline Functions' input field. Below that is a 'File Status' field with the text 'No Spline File Selected'. Below this are two buttons: 'Open Spline File' and 'Open Default Spline File'. At the bottom of this section is an empty 'File Path' field.

**Figure 3.20** – *Track/Spline* Tab

**Track File:** To load a track file into ATTIF first an appropriate *.dat* file must be opened. The “Open Track File” button will open a browser that allows the user to search for the desired file. If “Open Default Track File” is clicked, then the default track of ATTIF (*SamsCrvt.dat*) will be opened. Once the track file is opened the file path will be displayed and the track can be loaded by clicking “Load Track Data”.

**Spline File:** As mentioned before, if contact has been included in the model, then spline functions can be utilized in the *Track/Spline* Tab. The Number of Spline Functions box refers to the number of spline functions defined in the spline data file. This value is typically 3 (for left rail, right rail, and center line splines). Opening a spline file for the loaded track is similar to the procedure for a track; however the spline does not need to be loaded after opening.

### 3.1.5 Recorded Control Tab

Tractive effort, dynamic brake, coupler activation, and air brake positions can all be varied throughout a simulation by using the *Recorded Control* Tab, Fig. 3.21. This Tab is useful in prescribing acceleration/braking scenarios for a model.

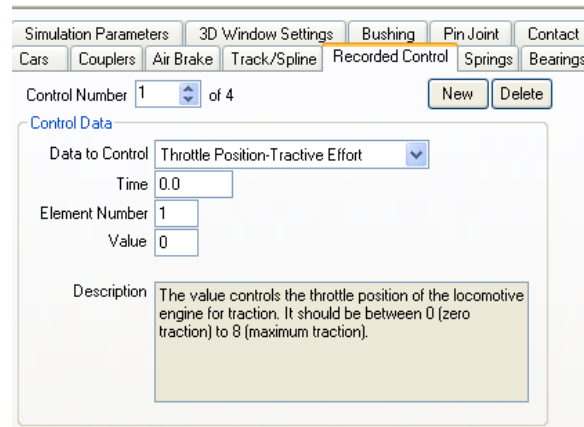
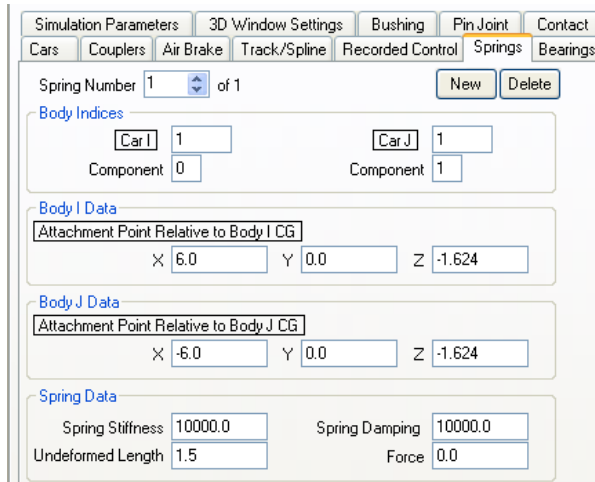


Figure 3.21 – *Recorded Control* Tab

**Control Data:** To create a vehicular control constraint, first click the “New” button at the top right. Then specify what type of control you would like by using the *Data to Control* Dropdown Menu. The time that the control is applied to the element must be entered into the *Time* box. *Element Number* refers to which locomotive the control is being set for, where *Element Number 1* is the locomotive with the lowest assigned *Car Number* and 2 is the second lowest, etc. Values for the selected control data may then be entered into the third data box. Descriptions of the control will be displayed in the *Description* text box which contains the allowed values for each type of control.

### 3.1.6 Springs Tab

One of the most common vibration control elements is the linear spring. The ATTIF interface allows the user to define springs to study railcar suspension systems by using the *Springs* Tab, Fig. 3.22.

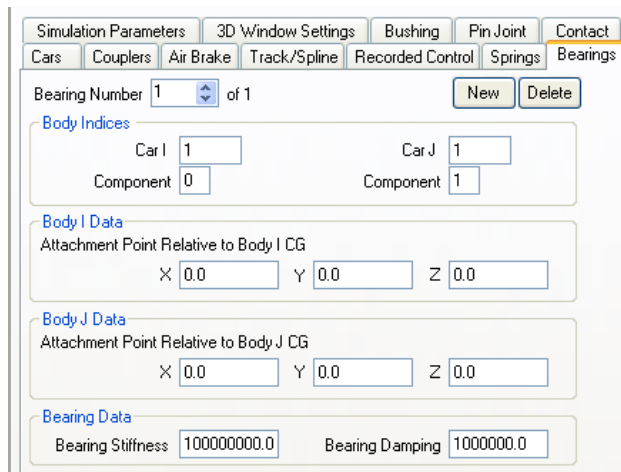


**Figure 3.22** – *Springs* Tab displaying default values for a newly created spring

Springs do not require much data to define and the process is similar to the procedure to create couplers which was explained previously. These elements will not appear in the Graphics Window.

### 3.1.7 Bearings Tab

Another suspension/vibration reduction element that is available to the user is a bearing. Bearings may be added in one direction between two bodies in the *Bearings* Tab, Fig. 3.23. These elements will not appear in the Graphics Window.

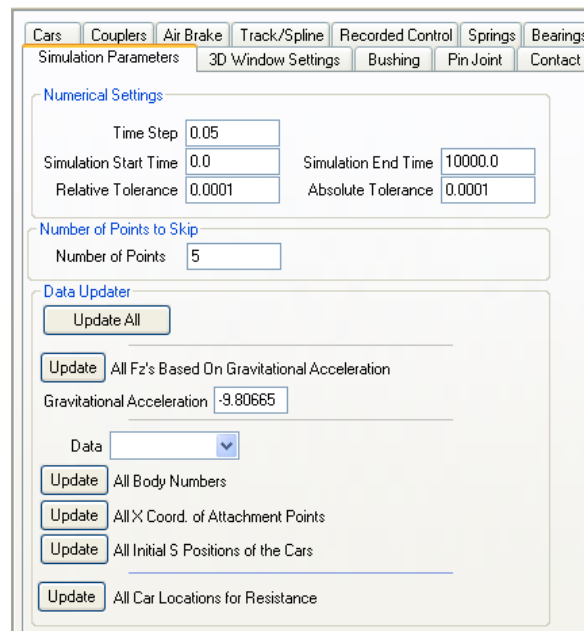


**Figure 3.23** – *Bearings* Tab

Bearing data is entered the same way as in the other Tabs. Always be sure to check body dimensions in the Cars Tab to verify the locations of your suspension elements.

### 3.1.8 Simulation Parameters Tab

The eighth tab of the *Data Panel* is the *Simulation Parameters* Tab, Fig. 3.24. This Tab includes very important settings that the user must be sure to check to have a successful simulation.



**Figure 3.24** – *Simulation Parameters* Tab

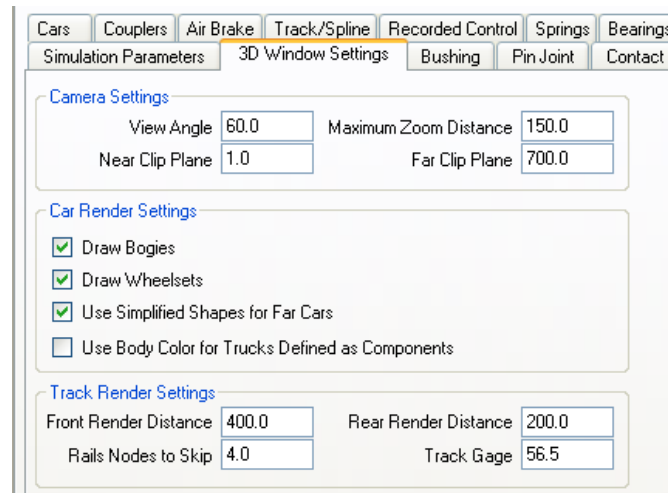
**Numerical Settings:** The *Time Step* of the simulation is defined as the results printing interval between each successive execution of the software's mathematical algorithms. This value will greatly affect the computational time of the simulation and therefore must be adjusted accordingly. The *Simulation Start Time* and *Simulation End Time* must also be entered in this section as well as the *Relative Tolerance* and *Absolute Tolerance* of the integrator.

**Number of Points to Skip:** This section defines the number of time step points that the Graphics Window will skip in order to speed up the graphics display. Note that this does not affect computational accuracy.

**Data Updater:** The buttons in this section of the *Simulation Parameters* Tab may be used to update the existing data of various features of the model.

### 3.1.9 3D Window Settings Tab

The Graphics Window is a convenient feature for constructing and visually evaluating a model. However, if the default settings are not optimal, then they may be changed in the *3D Window Settings* Tab, Fig. 3.25. The default settings will typically be enough for the majority of simulations.



**Figure 3.25** – *3D Window Settings* Tab

### 3.1.10 Bushing Tab

The third available vibration reduction element is the bushing. Bushings reduce friction between bodies in three dimensions and may be added to a model in the *Bushing* Tab, Fig. 3.26.

Cars	Couplers	Air Brake	Track/Spline	Recorded Control	Springs	Bearings
Simulation Parameters	3D Window Settings	Bushing	Pin Joint	Contact		

Bushing Number 1 of 6 New Delete

**Body Indices**

Car I 1 Car J 1  
Component 0 Component 2

**Body I Data**

Attachment Point Relative to Body I CG  
X 4.32 Y 0.0 Z -2.0

**Body J Data**

Attachment Point Relative to Body J CG  
X1 0.0 Y1 0.0 Z1 0.0  
X2 0.0 Y2 0.0 Z2 0.1

**Bushing Stiffness**

Kx 10000000.0 Ky 10000000.0 Kz 10000000.0  
Kph 1000000.0 Kth 1000000.0 Kps 1000000.0

**Bushing Damping**

Cx 100000.0 Cy 100000.0 Cz 100000.0  
Cph 100000.0 Cth 100000.0 Cps 100000.0

**Bushing Preload Forces**

Fx 0.0 Fy 0.0 Fz 0.0  
Tph 0.0 Tth 0.0 Tps 0.0

**Figure 3.26 – Bushing Tab**

Data for bushings are similar to the previously discussed suspension elements with the exception that bushings may be attached across multiple planes. The second row of  $x$ ,  $y$ , and  $z$  coordinate boxes in the *Body J Data* section allow the user to define a second point on Body  $j$  that the bushing's center is aligned with.

### 3.1.11 Pin Joint Tab

A pin joint (also known as a revolute joint) is a two constrain a pair of bodies to one degree of freedom about a single axis of rotation. The *Pin Joint* Tab, Fig. 3.27, allows the user to employ this mechanical feature in a model. As with the bushing element, a pin joint may be created in any direction from the first body to the second body by creating lines with each row of attachment coordinates.



Cars	Couplers	Air Brake	Track/Spline	Recorded Control	Springs	Bearings
Simulation Parameters	3D Window Settings	Bushing	Pin Joint	Contact		

Pin Joint Number  of 1

**Body Indices**

Car I	<input type="text" value="1"/>	Car J	<input type="text" value="1"/>
Component	<input type="text" value="0"/>	Component	<input type="text" value="1"/>

**Body I Data**  
Attachment Point Relative to Body I CG

X1	<input type="text" value="0.0"/>	Y1	<input type="text" value="0.0"/>	Z1	<input type="text" value="0.0"/>
X2	<input type="text" value="0.0"/>	Y2	<input type="text" value="0.0"/>	Z2	<input type="text" value="0.0"/>

**Body J Data**  
Attachment Point Relative to Body J CG

X1	<input type="text" value="0.0"/>	Y1	<input type="text" value="0.0"/>	Z1	<input type="text" value="0.0"/>
X2	<input type="text" value="0.0"/>	Y2	<input type="text" value="0.0"/>	Z2	<input type="text" value="0.0"/>

**Figure 3.27 – Pin Joint Tab**

### 3.1.12 Contact Tab

The last Tab of the *Data Panel* is the *Contact* Tab, Fig 3.28. This tab is essential in creating models where there is wheel-rail contact involved. A new contact must be created for each wheel that the user wants to include contact for. This can become a lengthy process for large, detailed models, but by using and familiarizing yourself with this Tab it will become much easier to properly define all the necessary contact points for your model. The Appendix contains an example input data file which includes wheel-rail elastic contact.

Bodies	Couplers	Air Brake	Track/Spline	Recorded Control	Springs	Bearings
Simulation Parameters		3D Window Settings		Bushing	Pin Joint	Contact
Contact Number 1 of 8 <span style="float:right">New Delete</span>						
<b>Contact Body Indices</b>						
Body I			Body J			
Body # 15			Rail			
Component 1						
<b>Contact Parameters</b>						
ICMOD Single Spline			JCMOD Single Spline			
ITWOC Other			TOL 0.003			
ICSPL 1			JCSPL 2			
ICREP 1			ICTJP 2			
<b>Contact Profile</b>						
Surface Parameters						
S1 (Wheel) 0.050310686			S2 (Wheel) 0.0			
S1 (Rail) 90.0			S2 (Rail) 0.054073351			
Coordinate of Wheel Profile Frame origin						
X 0.0		Y -0.735		Z 0.0		
Coordinate of Rail Profile Frame origin						
X 0.0		Y -0.755		Z 0.0		
Distance of Wheel Center From Center of Wheel Set						
D -0.6943						
<b>Contact Creepage</b>						
ICRV Creepage Force			Friction Coef. 0.5			
E (Wheel) 21000000000			E (Rail) 21000000000			
G (Wheel) 80000000000			G (Rail) 80000000000			
P (Wheel) 0.3			P (Rail) 0.3			
RR (Wheel) 0.0			RR (Rail) 0.0			
RT (Wheel) 0.0			RT (Rail) 0.0			
Flang Fric. Coef. 0.5			Psi 1.5708			

**Figure 3.28 – Contact Tab**

**Contact Body Indices:** After creating a new contact by clicking the “New” button, the *Body Number* and *Component Number* of the element to be in contact with the rail must be entered in the appropriate data box.

**Contact Parameters:** ICMOD and JCMOD indicate the method that will be used to define the profile of Wheel/Rail respectively and for the current version the Spline is the only choice. ICSPL and JCSPL specified the Spline function number that will be used by Wheel/Rail respectively. ICREP is flag used to define the creep force model.

**Contact Profile:** S1(Wheel) and S2(Wheel) are initial value of lateral and angular wheel surface parameters. S1(Rail) and S2(Rail) are initial value of longitudinal and lateral rail surface parameters. RX(Wheel), RY(Wheel) and RZ(Wheel) are the x, y, z position of the origin of the surface coordinate system on the wheel with respect to the body coordinate system. RX(Rail), RY(Rail) and RZ(Rail) are the x, y, z position of the origin of the surface coordinate system on the rail WRT the body coordinate system. Wheel center is the lateral distance of the wheel center to the wheelset center of gravity.

**Contact Creepage:** ICRV is the creep force model which the user can refer to in the ICREP.  $E_{\text{Wheel/Rail}}$ ,  $G_{\text{Wheel/Rail}}$  and  $\nu_{\text{Wheel/Rail}}$  are the elastic modulus, shear modulus and Poisson ratio of the Wheel/Rail respectively.  $\Psi$  is the angle between the normal planes that contain the  $1/RRW$  (principle rolling radius of the wheel) and  $1/RRR$  (principle rolling radius of the rail). Flang. Fric. Coef. is the coefficient of friction of the flange contact.

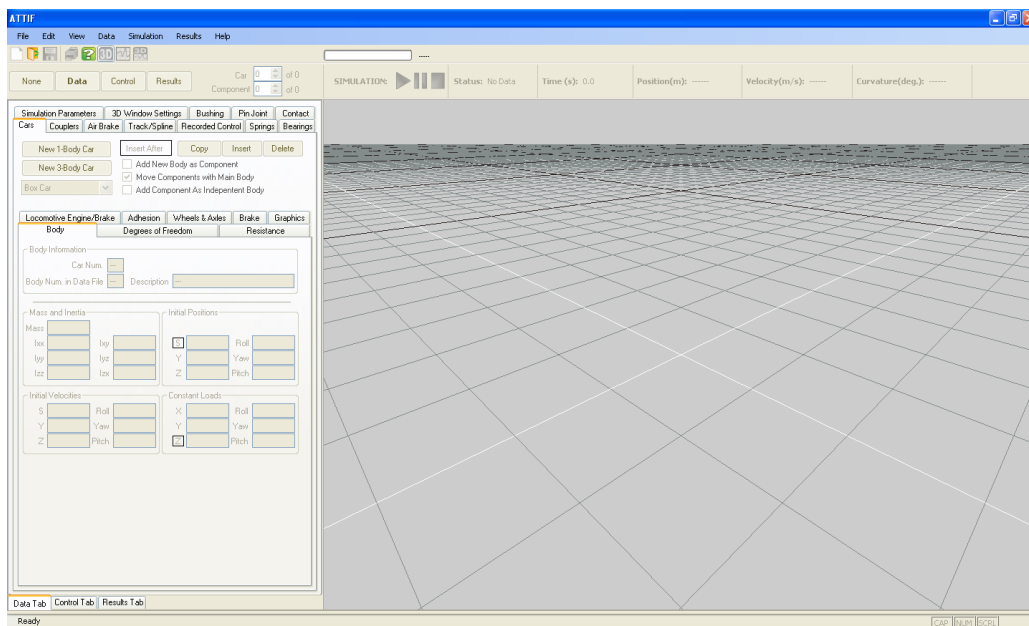
## 4. Model Examples

This chapter will reinforce the material of the previous chapters through step-by-step examples of how to best use the interface to create, simulate, and analyze an ATTIF model. Following an example while simultaneously using ATTIF to create the example will be valuable in familiarizing yourself with the software.

### 4.1 Example #1: 5 car consist of 1-Body vehicles

This example gives a brief introduction to the most common features of ATTIF. The model created will be very simple, but this example is a good start to learn how to utilize the application. Follow along with the subsequent steps to build, simulate and analyze a 5 car consist of 1-Body rail vehicles.

**Step 1:** Open ATTIF by running the ATTIF.exe file on your computer. Upon opening the main ATTIF window will be displayed.



**Fig. 4.1** – Main ATTIF Window

**Step 2:** To begin building the model we must first create a new file for the data to be written to. Do this by selecting *New* from the *File Dropdown Menu*, or by clicking on the *Create New File Button* from the toolbar. After you do this, some of the data buttons in the Data Entry Panel will no longer be grayed out, and any entered data will be written to the new file you have created. Note that the file is automatically named Attifmodel.dat as

New File Button



Fig 4.2 – Create New File Button

**Step 3:** To create the first car of the model click on the *New 1-Body Car button* in the *Cars* Tab of the *Data Entry Panel*. A box car should now appear in the *Graphics Window* and its default data will occupy the data boxes of the opened *Tab*. The image below shows the results of this step. This body of this first car starts at the origin which is the intersection of the two white lines in the *Graphics window*. This is the position we wish for it to be in, so we will not make any changes to its default data. Also, note from the *Degrees of Freedom* Sub-Tab that the model is constrained to the *S* direction (see Fig. 4.4).

New 1-Body Car Button

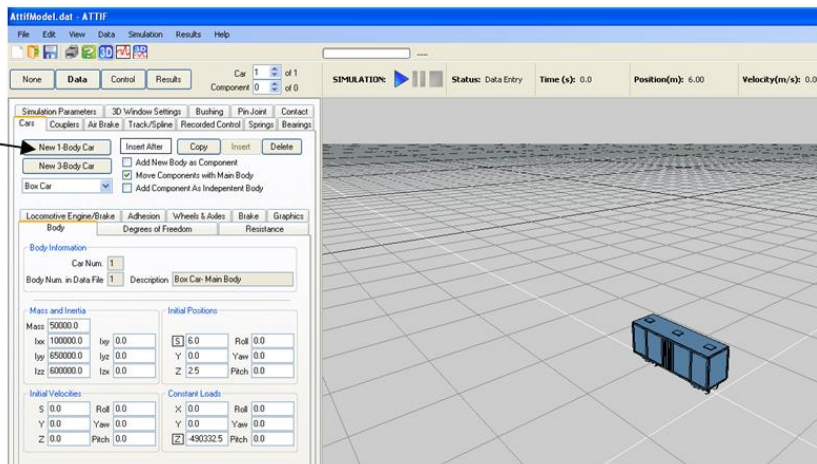
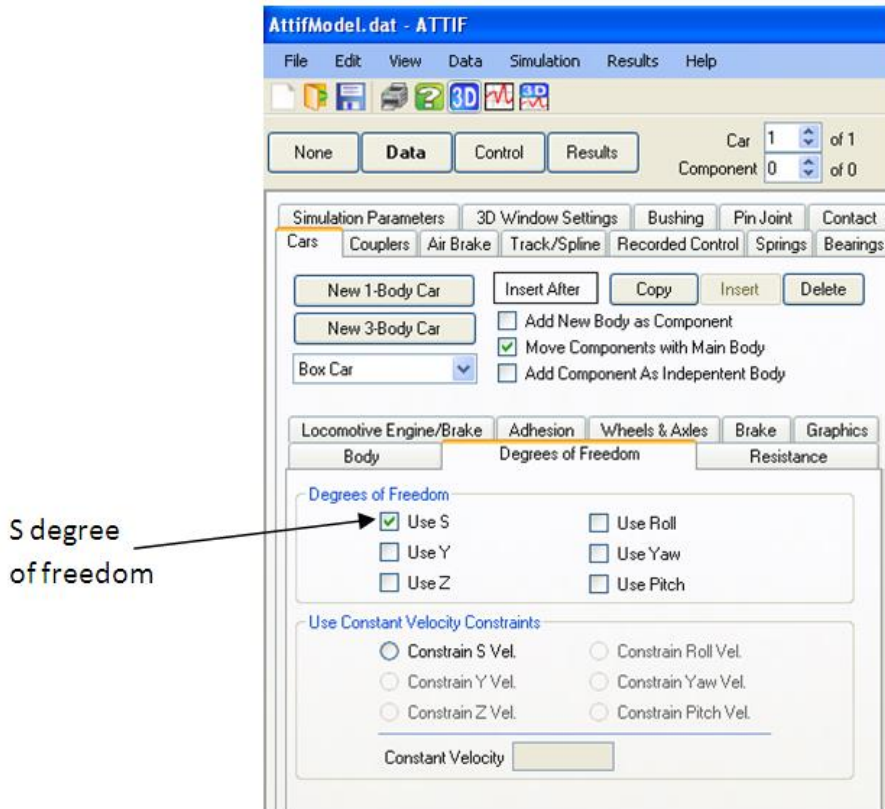
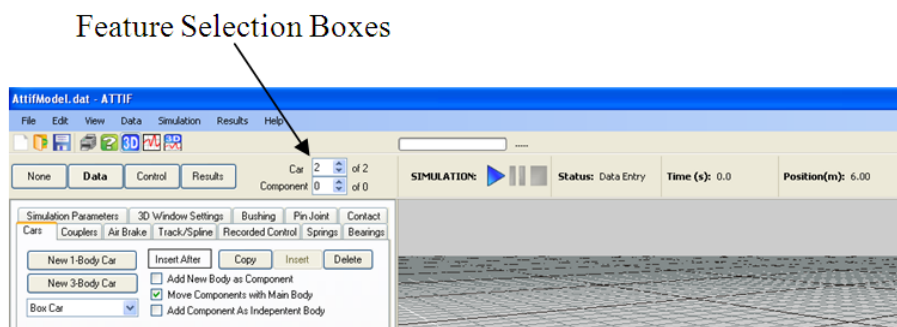


Fig 4.3 – New 1-Body Car Button



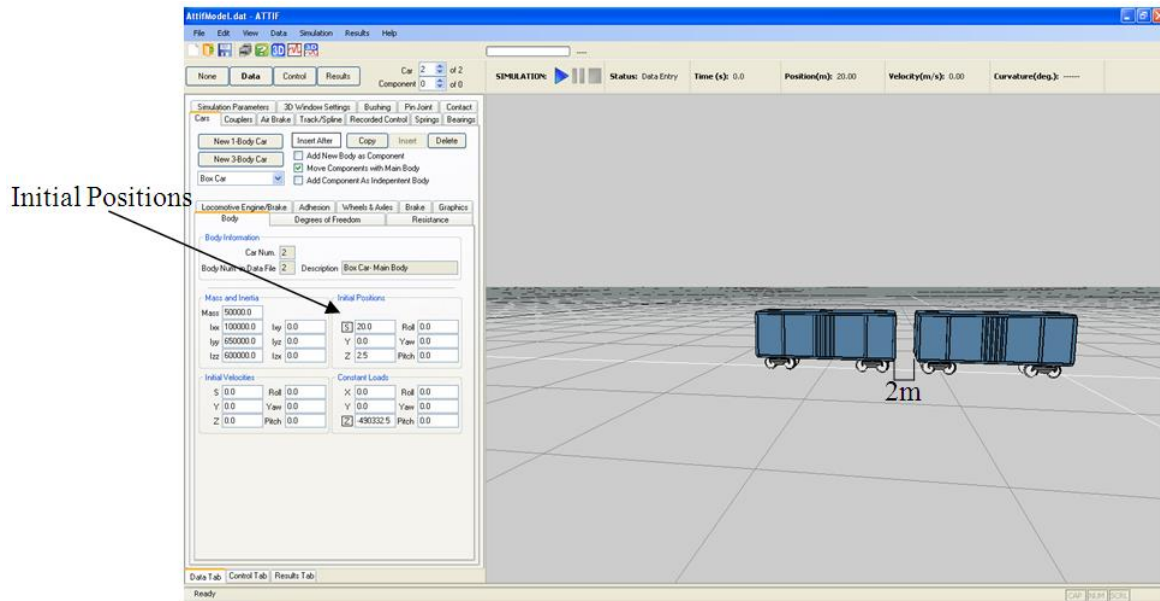
**Fig 4.4** – Degrees of Freedom Sub-Tab

**Step 4:** To create another car click the *New 1-Body Car* button. A second 1-Body box car with default parameters will now be written to the data file. Note that the Graphics Window will still show only one box car. This is because the second car is in the exact same position as the first car we made. We will relocate it in the next step. Also note the Feature Selection Boxes, the number 2 should now be displayed next to Car. Remember that the arrows can be used to move between Cars and components to edit data. Fig 4.5 below shows this step and references the Feature Selection Boxes.

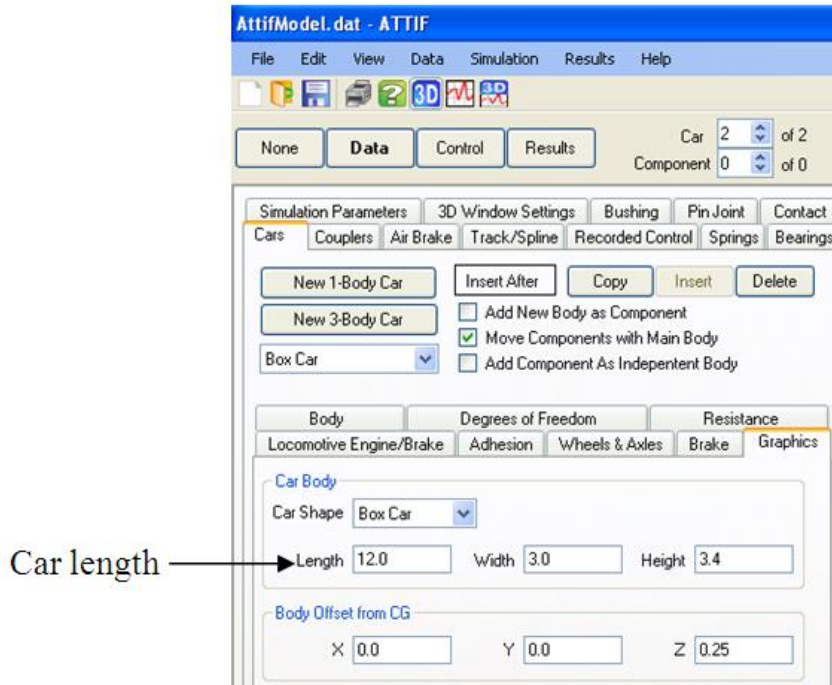


**Fig 4.5** – Feature Selection Boxes

**Step 5:** We must now edit the parameters of the second car to the needs of the desired model. First, change the location of the car by entering 20 into the S data box in the Initial Positions section. For the value to be applied, click in another data box and you will see the car relocate in the Graphics Window to the entered position. This will move the center of gravity (CG) of the vehicle to this position in the S-direction (remember that this is the same as the x-direction in the standard Cartesian coordinate system). The image below shows the new initial position of Car 2 and the 2m gap between the two cars. Since the vehicles are both 12m long (Fig.4.7), the CG of Car 2 being at 20m will leave a 2m gap after the first car. The Graphics Sub-Tab shows how long each vehicle is and can be edited there as well. Also remember that you may change the view of the Graphics Window by holding down the left mouse-button over the Graphics Window and dragging then releasing at the desired position.

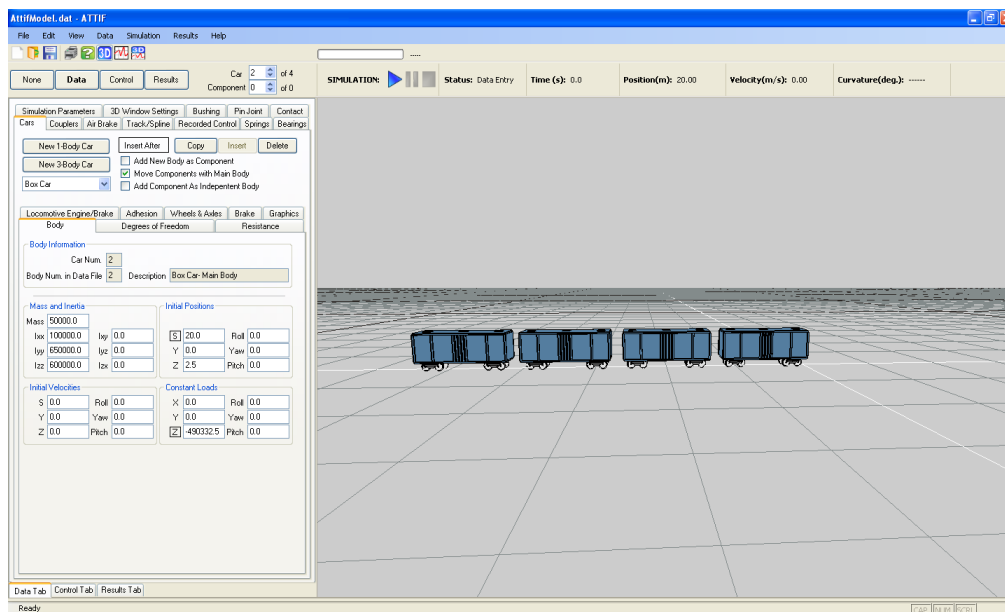


**Fig 4.6 – Initial Positions Data Entry Boxes**



**Fig 4.7 – Vehicle Graphics Sub-Tab**

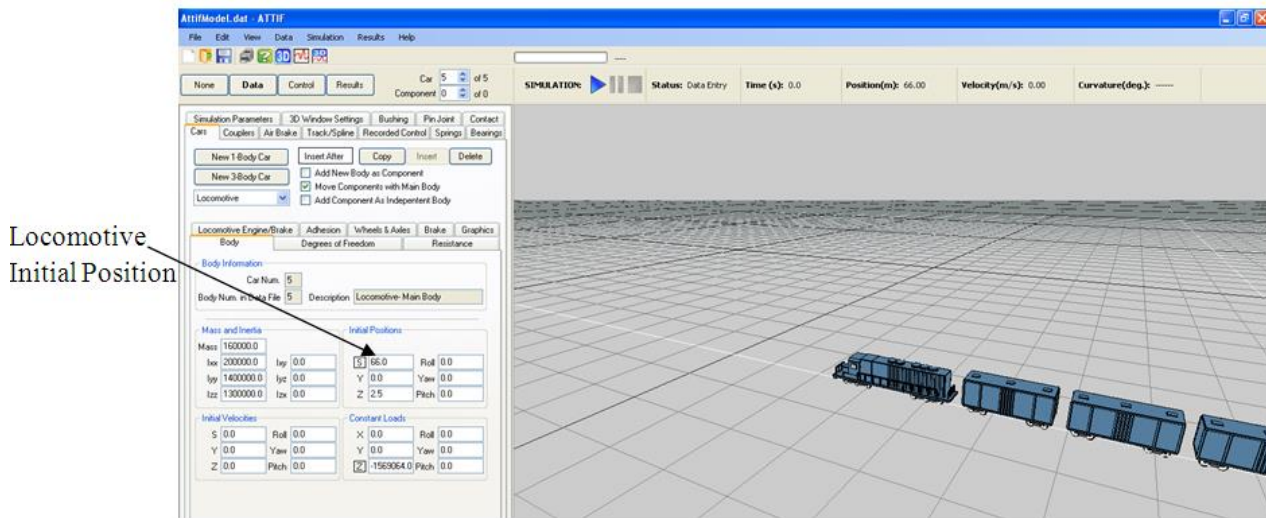
**Step 6:** Now that the first two cars have been built, follow the steps that we used to create the second car and build a third and fourth box car at 34 and 48m along the S-direction, respectively. The image below should result and there should be a 2m gap between each consecutive car.



**Fig. 4.8 – Four Box Cars in Graphics Window**

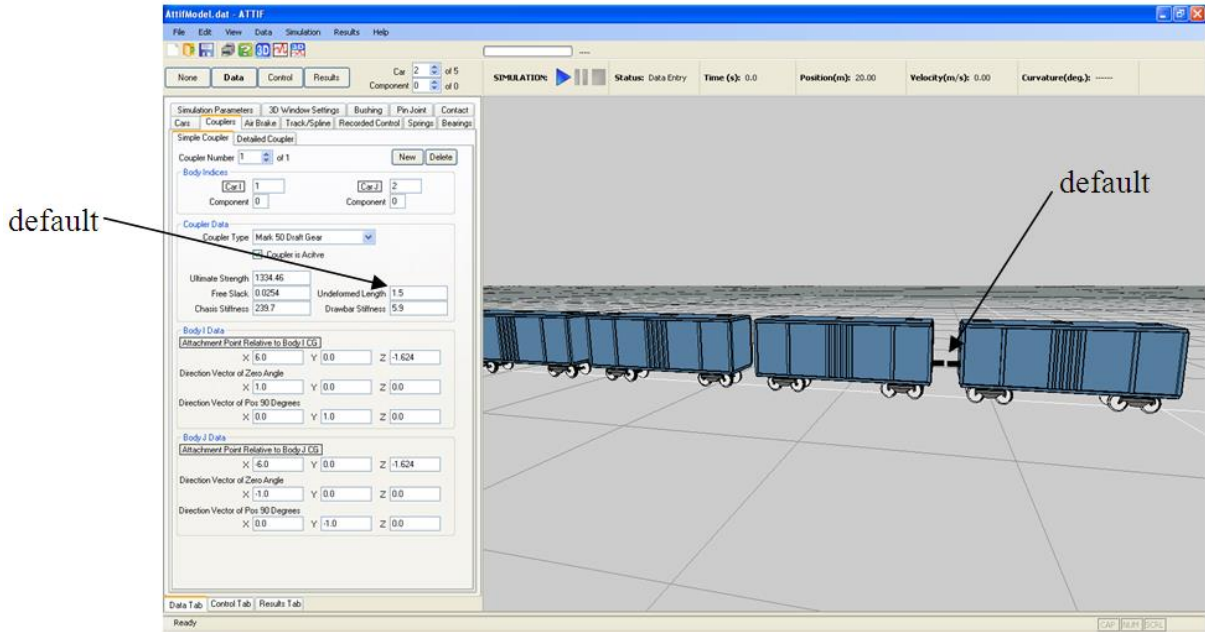


**Step 7:** With Car 4 selected in the Feature Selection Box, create a locomotive by selecting ‘locomotive’ from the Vehicle Type Dropdown Menu and clicking the *New 1-Body Car* button. This will make a locomotive and display it at the origin in the Graphics Window. Set its S initial position to 66m (the locomotive is 20m long). You should now have the image displayed below in Fig. 4.9 showing the locomotive (Car 5) in the lead position of the consist.

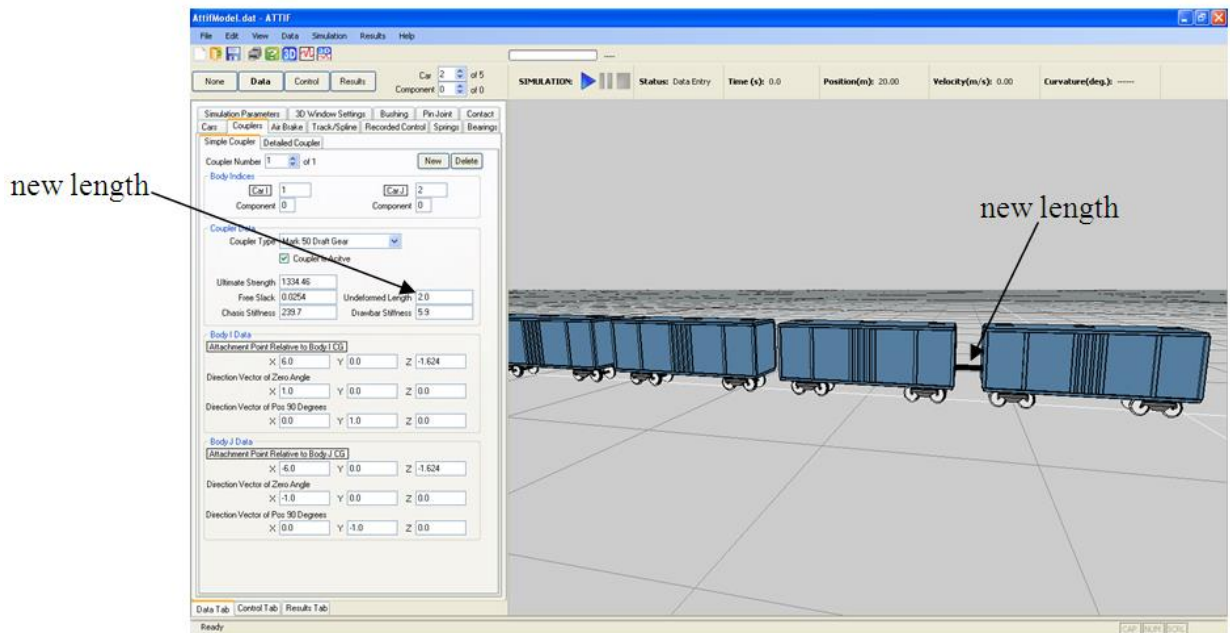


**Fig. 4.9** – Locomotive Initial Position

**Step 8:** The next important feature we must add are couplers. One coupler must be created between each set of cars to transfer the motion of the locomotive to the trailing cars of the consist. Select the *Couplers* Tab in the Data Entry Panel to begin creating the four necessary couplers for this model. Click the *New* button in the *Couplers* Tab to create the first coupler and un-gray the data boxes within the Tab. The image below shows the new coupler with its default data values and its location in the Graphics Window. Car *I* should automatically be set as Car 1 and Car *J* as Car 2 in the *Body Indices* Section of the Tab. Notice that the cars are not connected by the coupler because its default undeformed length does not cover the 2m gap we left between the box cars. Change the undeformed length to 2m and watch the Graphics Window to see the change. The images below show the coupler with the default undeformed length and then the new length that we have just entered. Keep all the other parameters of this coupler as their default. The *Z Attachment Points Relative to Body CG* are displayed in the Graphics Window at the CG point until the simulation begins when, in this model, they will immediately move -1.624m downwards at t=0.0 seconds and connect the vehicles appropriately.



**Fig 4.10 – Default Coupler Undeformed Lengths**



**Fig. 4.11 – New Defined Coupler Undeformed Lengths**

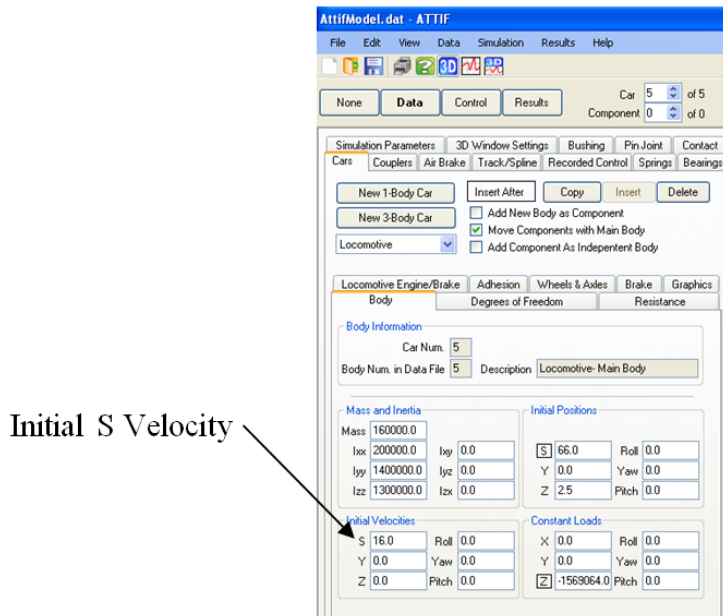
**Step 9:** Now the three other couplers must be created. Click the *New* button in the *Couplers* Tab again and set *Car I* as *Car 2*, *Car J* as *Car 3*, and an undeformed length of 2m. For the third coupler we will follow the same procedure. Click the *New* button and set *Car I* as *Car 3*, *Car J* as *Car 4*, and the undeformed length as 2m. Remember that you can use the *Coupler Number* arrow buttons at the top left of the *Couplers* Tab to select which coupler's data is displayed in the panel. Notice that if you create a new coupler while having a coupler selected that is not the largest coupler number in the model, then this will create a coupler with an assigned number of one greater than the currently selected coupler (e.g. if coupler 2 is selected and there are 4 couplers in the model and you click *New*, then this new coupler will be *Coupler Number 3* and *Coupler Numbers 3* and *4* will be reassigned as *4* and *5*, respectively). This only affects the order in the data file and will not change the entered parameters. For the last coupler required we need to connect the fourth box car (*Car 4*) with the locomotive (*Car 5*). Click *New* and set *Car I* as *Car 4*, *Car J* as *Car 5*, and the undeformed length as 2m. If you adjust your Graphics Window to visualize this last coupler, then you will notice that it is not completely connecting the two vehicles. This is because the locomotive longer than the box cars and so the default value for the *X Attachment Point Relative to Body J CG* in the *Body J* section must be edited to -10m. See Fig. 4.12 below for the graphics we now have for the model with the edited *X Attachment Point Relative to Body J CG* value for the locomotive referenced.



**Fig. 4.12** – Local Coupler Attachment Point On Locomotive

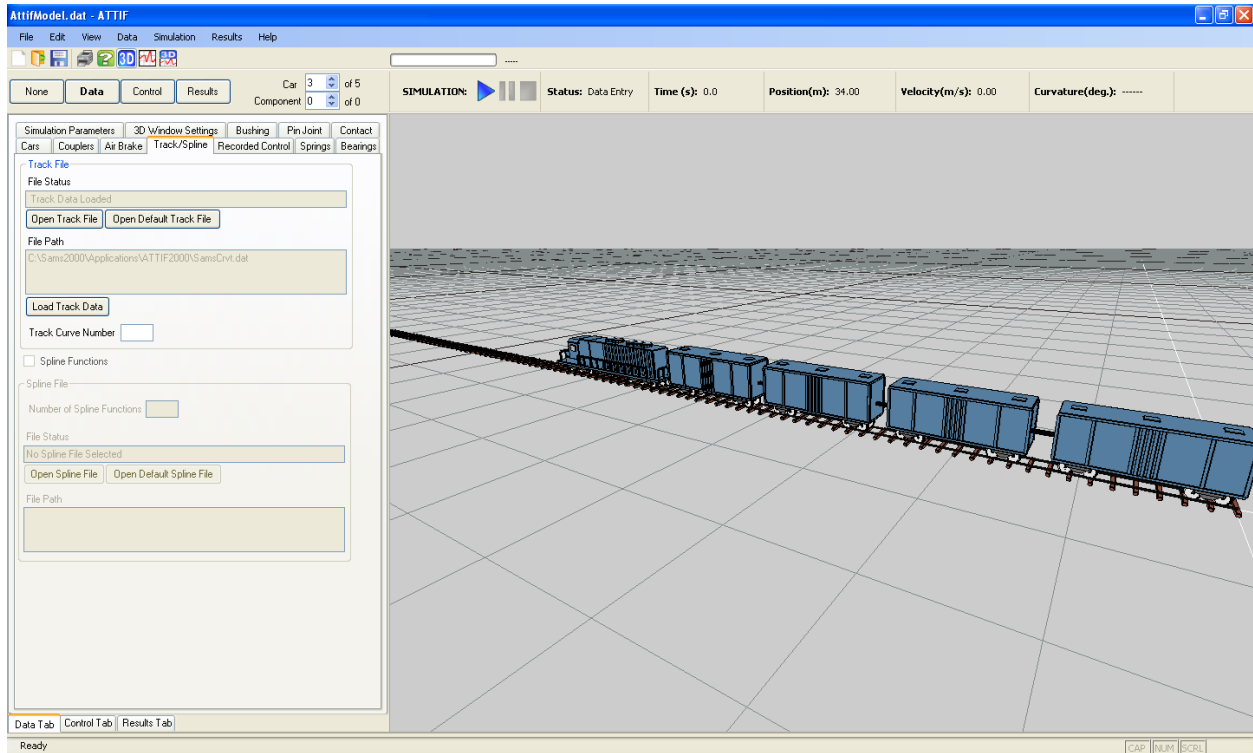
**Step 10:** Because all of the bodies in this model are constrained to just the S-direction it will not need any connections or suspension features that act in the vertical (z) or lateral (y) directions. So now we will edit the initial velocities of each car. Do this by selecting the *Cars* Tab → *Body* Sub-Tab → Enter 16 into the S data box of the *Initial Velocities* Section. This will set the initial velocity of the vehicle to 16m/s in the S-direction. Now use the Feature Selection Boxes to edit the S Initial Velocities on the four other rail cars

to 16m/s. The image below shows the new value for the s-direction initial velocity of the locomotive.



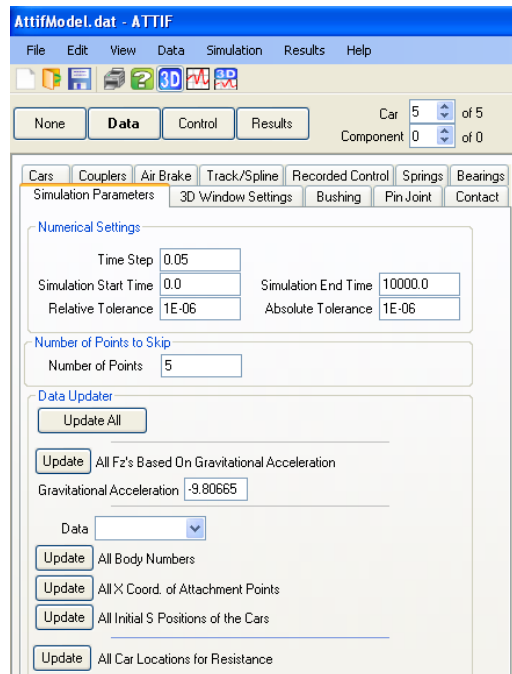
**Fig. 4.13** – Body Sub-Tab in the Cars Tab of the Data Panel

**Step 11:** The consist is now complete. However, we still need the track. To load a track file into ATTIF, first open the *Track/Spline* Tab in the Data Entry Panel. Then either click the *Open Track File* button to browse for the desired file or click the *Open Default Track File* button to open ATTIF's default track file (Samsrvt.dat). After you have made your selection, click the *Load Track Data* button. Now the track will be loaded into the data file and its graphic will be displayed (beginning at the origin) in the Graphics Window. Note that the Data Reading Status Window may appear when the track file is loaded, and recall that this may be prevented from appearing again by checking the *Do Not Show Data Reading Status After Successful Data File Readings* box at the bottom of the window. For this example no *Track Curve Number* is necessary because we are not using splines files and contact, so leave this data box blank. Fig. 4.14 shows our completed consist with the loaded default track file.



**Fig. 4.14** – Completed Consist With Loaded Track Data

**Step 12:** For good measure it is always important to check the *Simulation Parameters* Tab in the Data Entry Panel before beginning a simulation. Here the Time Step, Simulation Start and End Times, and Tolerances may be changed from their default. Also, the *Number of Points to Skip* may be edited. Enlarging this value will greatly increase the speed at which the simulation is executed. For now, leave everything in this Tab at its default. The *Simulation Parameters* Tab can be seen in Fig. 4.15 below.



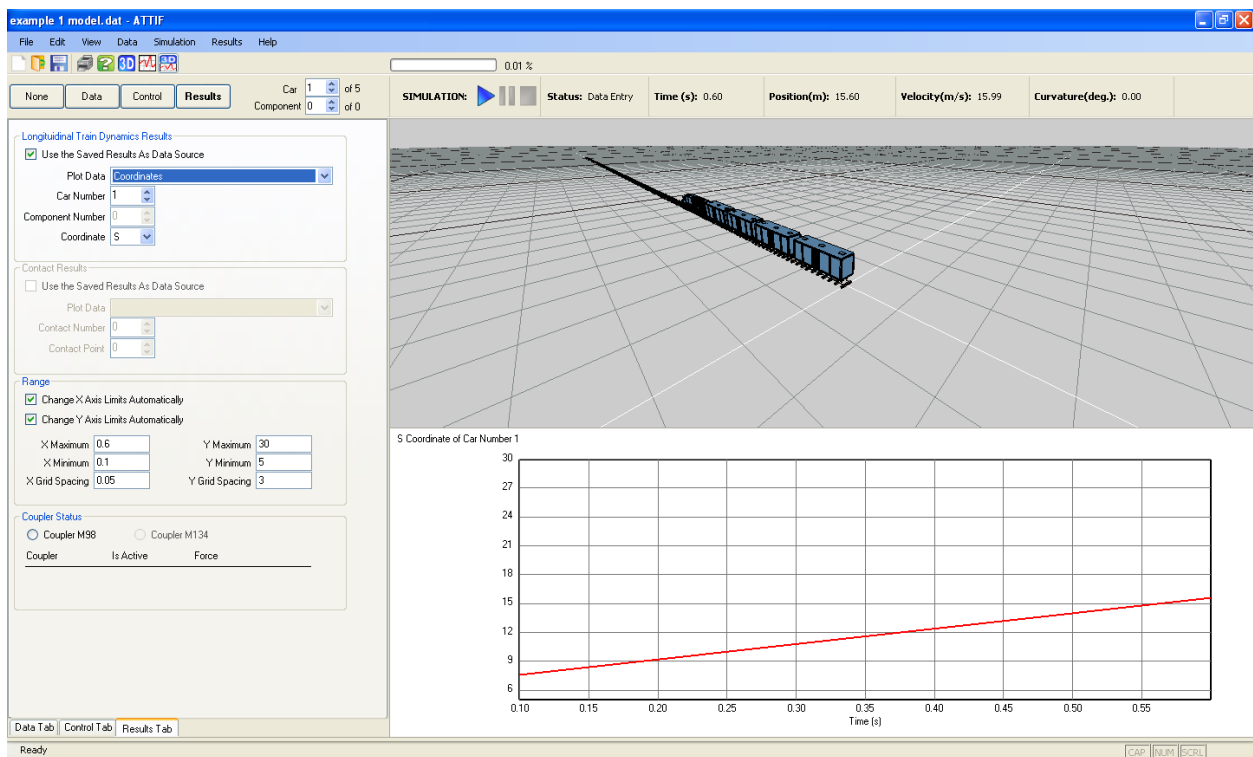
**Fig. 4.15** –Simulation Parameters Tab

**Step 13:** If you have followed all of the preceding steps correctly, then you are now ready to run the simulation of this example. First, go to the Menu Bar and bring up the *Results Dropdown Menu* and make sure that *Save Results During Run-Time* is checked. To begin the simulation, you may select *Run* from the *Simulation Dropdown Menu* in the Menu Bar or simply click the big blue arrow directly above the Graphics Window. After choosing one of these options, the interface will automatically open a window asking you to save the file because you have changed it from the default new file you originally created in Step 2. Chose the desired name and directory location of the file for this model and then click *Save*. The simulation will now commence until one of three things occur: the Simulation End Time is reached, the entire length of the track is traveled by the lead vehicle in the consist, or until an error occurs in the execution of the data file. Note that the simplicity of this model may cause it to run very quickly. Once the simulation has ended an alert window will appear. Click *OK* to close this window. Then click the blue square above the Graphics Window to stop the simulation. Although the simulation may have already finished, you need to click this button to view the results or to run the simulation again.

**Step 14:** You may now view the various results plots of the simulation we just completed by selecting the *Results* Button below the Toolbar. Click the *Split screen* button on the Toolbar to bring up a plot area on the lower portion of the Graphics Window, or the *Plot* button to replace the entire model display in the Graphics Window with the results plot.



Now check the *Use the Saved Results As Data Source* box, and select the desired data to plot from the *Plot Data Dropdown Menu*. You should now see the S-coordinate plot of Car 1 in the plot area of the Graphics Window. The X and Y Limits of the plot will be automatically adjusted by the program. If you wish to adjust the plot more appropriately, then you may utilize the Range section of the Results Data Panel to change the minimums, maximums, and grid spacing of the x and y-axes of the plot. Other data for different cars, components, and coordinate directions may be chosen as well using their respective selection boxes. The image below shows the S-coordinate results plot of the rear box car (Car 1) for the simulation. Note that your results may be slightly different in the case that the default track that you loaded is not exactly the same length or shape that I have used for this manual.



**Fig. 4.16** – Results Panel With S-Coordinate of Car 1 vs. Time Plot

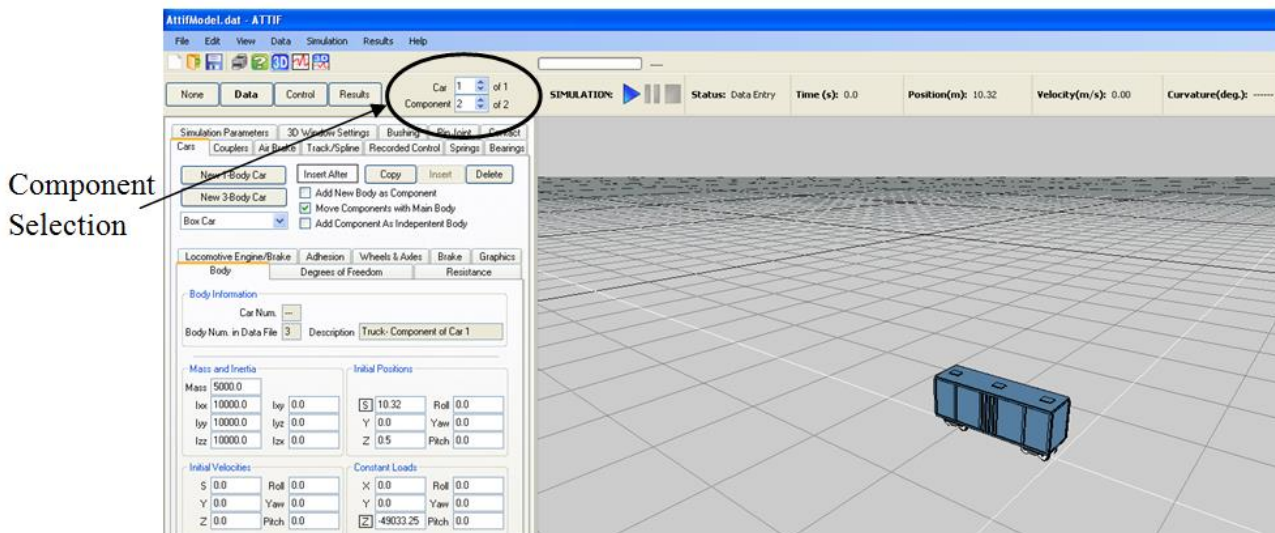
Congratulations you have just finished your first longitudinal train dynamics simulation in ATTIF! There are still many more features we will cover in the next few examples to help you utilize each one more affectively in your simulations. Continue with the next examples to learn more about suspension elements, locomotive control features, and wheel-rail contact.

## 4.2 Example #2: 15 car consist of 3-Body vehicles

This second example will familiarize the user with 3-Body vehicles, suspension components, and locomotive control features. Because this consist will include 15 vehicles, creating all of them will become very repetitive and so we will use tables to reference the correct parameters of the vehicles rather than going through each one step-by-step. This example also assumes that the user as already read the first example in the manual to prevent redundancy in each step.

**Step 1:** Open ATTIF and create a new file.

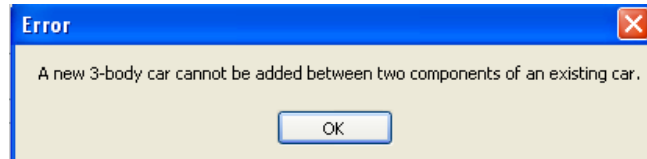
**Step 2:** In the *Cars* Tab of the Data Entry Panel select 'Box Car' from the vehicle type dropdown menu and then click the *New 3-Body Car* button. After doing so, the following image should result. Notice that the data for Component 2 is displayed. ATTIF assigns Component 0 to the main body of the vehicle, Component 1 to the rear bogie, and Component 2 to the lead bogie. The default location for this first vehicle is acceptable for this model and we will not adjust it.



**Fig. 4.17** – Car 1 of Example #2

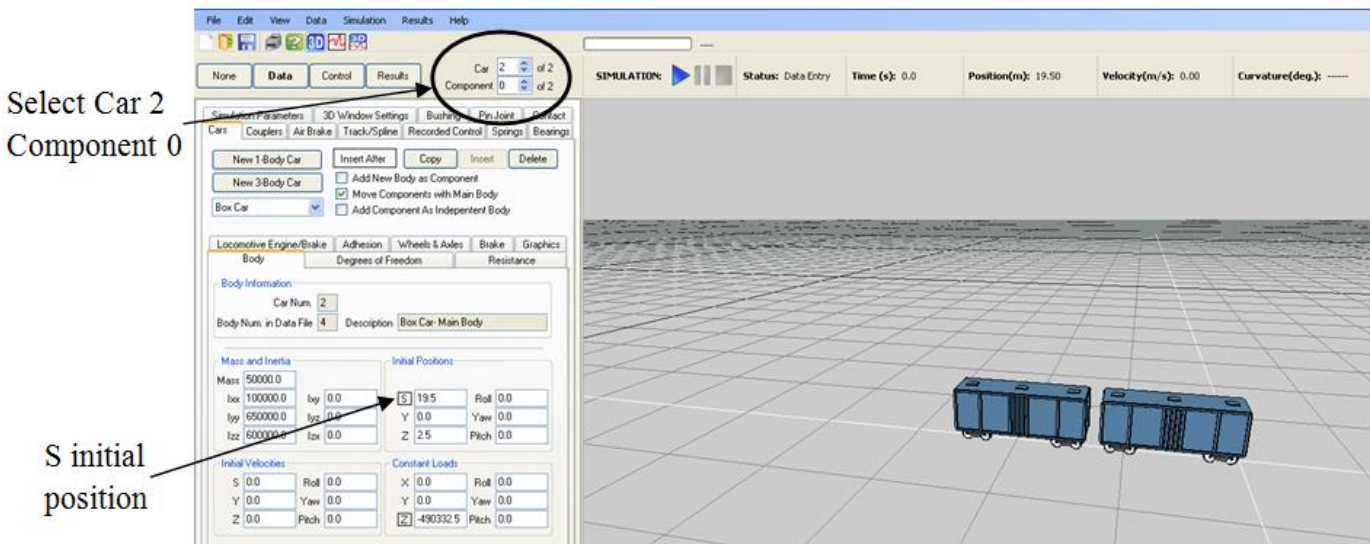
**Step 3:** To create the second vehicle, we need to make a few checks before we add it to the interface. First be sure that *Insert After* is displayed next to the *Copy* button, this will any newly created bodies after the presently selected body. Because we wish to add the next vehicle after the one we just created, be sure that you have Car 1/Component 2 selected in the Feature Selection Boxes (see above figure). Lastly, the only box in the *Cars* Tab that should be checked is *Move Components with Main Body*. Now click *New 3-Body Car* again to create the second Box Car. In the case that *Insert Before* was displayed rather than *Insert After*, the below error message will appear. This results because the new body cannot be added in between to existing components of a car. This error will also appear if the last component of the vehicle is not selected.





**Fig. 4.18** – ATTIF Error Warning

**Step 4:** Remember from the first example that when we added the second car that it is added in the default location (beginning at the origin), and thus cannot be seen until new initial positions are defined. To make this easier be sure you have the *Move Components with Main Body* box checked, as this will keep the bogies in their relative positions of the main body. Now select Component 0 of Car 2 from the Feature Selection Boxes and enter 19.5 for its S initial position. This should move the entire car (main body and 2 bogies) in front of the first car. The figure below displays what you should now have for your model.



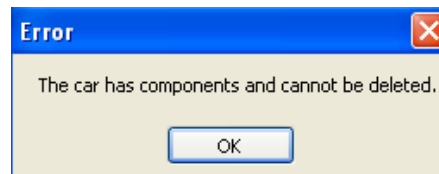
**Fig. 4.19** – Car 2 of Example #2

**Step 5:** For this step use what you have learned to create the next 13 vehicles listed in the following table. Remember to always have *Insert After* displayed and Component 2 selected of the most recent Car that you have created so that no errors will occur when you click *New 3-Body Car* to create the next vehicle in the consist (e.g. when creating the third car have Car 2/Component 2 selected). The vehicle will still be created at the default initial position, so have the *Move Components with Main Body* box checked so that you only have to enter a new initial position for the main body and not the bogies as well. Note that the lead bogie is typically +4.32m from the CG of the main body, and the rear bogie is -4.32m for any vehicle other than a locomotive ( $\pm 6.096$  for a locomotive).

Car #	Vehicle Type	S Initial Position
1	Box Car	6.0
2	Box Car	19.5
3	Box Car	33.0
4	Box Car	46.5
5	Locomotive	64.0
6	Hopper Car	81.5
7	Hopper Car	95.0
8	Hopper Car	108.5
9	Hopper Car	122.0
10	Locomotive	139.5
11	Tank Car	157.0
12	Tank Car	170.5
13	Tank Car	184.0
14	Tank Car	197.5
15	Locomotive	215.0

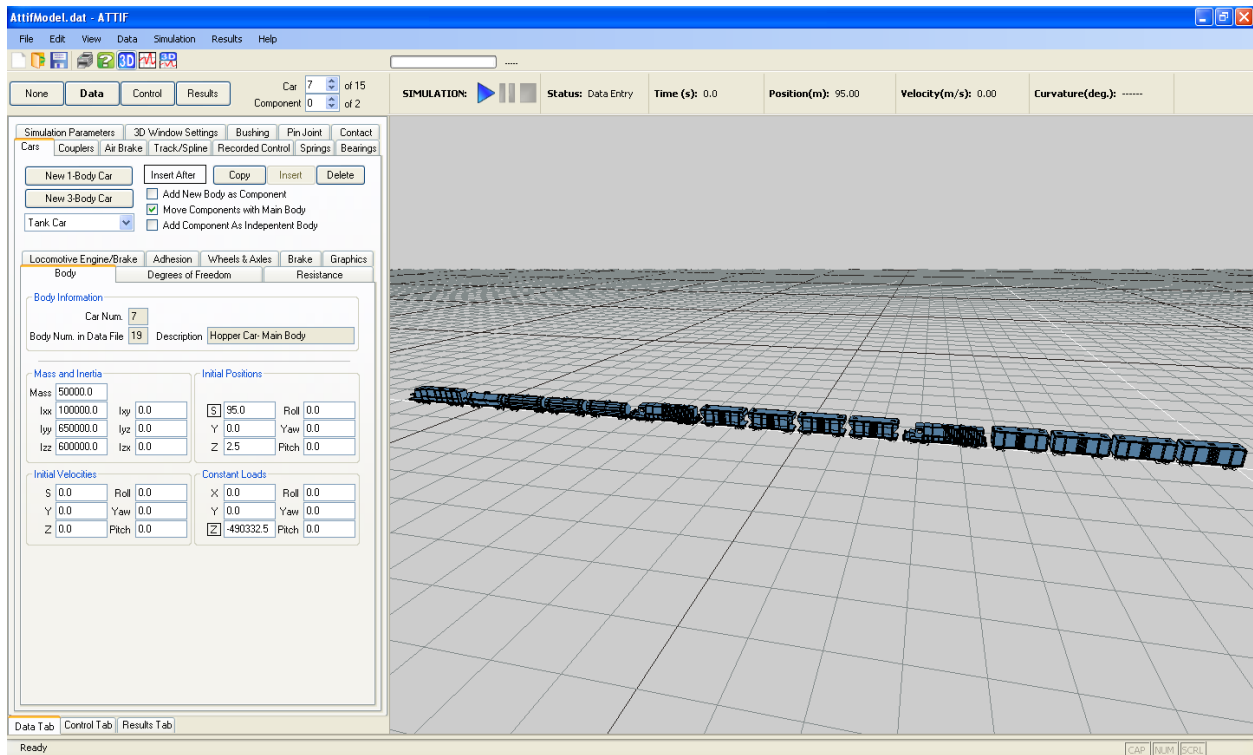
**Fig. 4.20** – Example #2 Vehicle S Initial Positions

**Step 6:** You may have had some trouble creating all of the Cars in the previous step. To delete a 3-Body Car, select Component 2 of the Car and click the *Delete* Button in the *Cars* Tab. This will remove the lead bogie of the car. Then select Component 1 and click *Delete* to remove the rear bogie. And again, select Component 0 and click *Delete* to remove the main body. In the case that you did not delete the two bogies before clicking the *Delete* button while having the main body selected, the following error message will appear.



**Fig. 4.21** – Component Error Message

At this point you should have all 15 Cars in there correct initial positions (1.5m spacing between each vehicle). The figure below shows the Graphics Window.



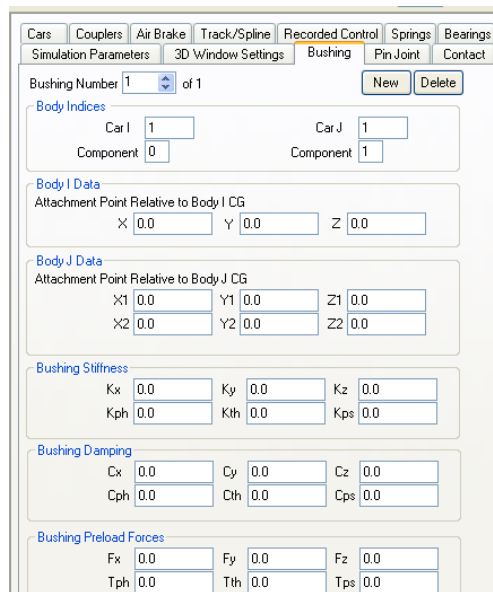
**Fig. 4.22** – Example #2 Consist

**Step 7:** As in the previous example, we need to attach each vehicle pair by creating couplers. We will again use simple couplers for this example. Only change the Car Numbers, Component Numbers, and X Attachment Point Relative to Body CG for each car. All of the other parameters will be kept at their default. The undeformed length will not need to be changed because its default value is 1.5m. Use what you learned in Example #1 and the table below to use the interface to create the 14 necessary simple couplers for this example.

Steps to remember when adding new couplers:				
1. Go to <i>Couplers</i> Tab/ <i>Simple Coupler</i> Sub-Tab and click <i>New</i>				
2. Enter rear Car # for Car I and front Car # for Car J				
3. Enter Component 0 for both Car I and J				
4. Adjust the attachment points of the coupler				
5. $\pm 6$ for standard cars, $\pm 10$ for locomotives				
Example #2 Couplers:				
Coupler #	Car I	Car J	Body I x attachment point	Body J x attachment point
1	1	2	6.0	-6.0
2	2	3	6.0	-6.0
3	3	4	6.0	-6.0
4	4	5	6.0	-10.0
5	5	6	10.0	-6.0
6	6	7	6.0	-6.0
7	7	8	6.0	-6.0
8	8	9	6.0	-6.0
9	9	10	6.0	-10.0
10	10	11	10.0	-6.0
11	11	12	6.0	-6.0
12	12	13	6.0	-6.0
13	13	14	6.0	-6.0
14	14	15	6.0	-10.0

**Fig. 4.23** – Coupler Attachment Data for Example #2

**Step 8:** Now that each vehicle is connected by a coupler, we must connect each car’s 3 components together. For this we will utilize bushing elements in the *Bushing* Tab of the interface. To keep this example simple, each standard car will have two bushings (one connecting the rear bogie to the main body, and one connecting the front bogie to the main body) and each locomotive will have four (two for the rear bogie, and two for the front bogie) for a total of 36 bushing elements for this example. The figure below shows the *Bushing* Tab.



**Fig. 4.24** – Bushing Sub-Tab

**Body Indices:** This section is used to enter the bodies that are connected by the bushing element.

**Body I Data:** The Attachment Points Relative to Body *I* CG can be entered here. Body *I* corresponds to the component number entered for Car *I*.

**Body J Data:** The Attachment Points Relative to Body *J* CG can be entered here. Body *J* corresponds to the component number entered for Car *J*. The second row of coordinates (X2, Y2, Z2) are used to create a line that the bushing's center is aligned with.

**Bushing Stiffness:**

- |        |                                    |
|--------|------------------------------------|
| 1. Kx  | Stiffness in the x-direction (N·m) |
| 2. Ky  | Stiffness in the y-direction (N·m) |
| 3. Kz  | Stiffness in the z-direction (N·m) |
| 4. Kph | Stiffness about the x-axis (N·m)   |
| 5. Kth | Stiffness about the y-axis (N·m)   |
| 6. Kps | Stiffness about the z-axis (N·m)   |

**Bushing Damping:**

- |        |                                    |
|--------|------------------------------------|
| 1. Cx  | Damping in the x-direction (N·s/m) |
| 2. Cy  | Damping in the y-direction (N·s/m) |
| 3. Cz  | Damping in the z-direction (N·s/m) |
| 4. Cph | Damping about the x-axis (N·s/m)   |
| 5. Cth | Damping about the y-axis (N·s/m)   |
| 6. Cps | Damping about the z-axis (N·s/m)   |

**Bushing Preload Forces:**

- |        |                              |
|--------|------------------------------|
| 1. Fx  | Force in the x-direction (N) |
| 2. Fy  | Force in the y-direction (N) |
| 3. Fz  | Force in the z-direction (N) |
| 4. Tph | Force about the x-axis (N)   |
| 5. Tth | Force about the y-axis (N)   |
| 6. Tps | Force about the z-axis (N)   |

To create a bushing, click the *New* button in the *Bushings* Tab. The information required to successfully create the 36 bushing elements in this example are tabulated below. They will all be fitted in the z-direction (vertical). The stiffness, damping, and preloads are the same for all bushings. Note that values may be entered using power multipliers (e.g. 10e6 may be entered into the data boxes for an equivalent entry of 10,000,000).

<u>Kx</u>	<u>Ky</u>	<u>Kz</u>	<u>Kph</u>	<u>Kth</u>	<u>Kps</u>
10e6	10e6	10e6	10e5	10e5	10e5
<u>Cx</u>	<u>Cy</u>	<u>Cz</u>	<u>Cph</u>	<u>Kth</u>	<u>Kps</u>
10e4	10e4	10e4	10e4	10e4	10e4
<u>Fx</u>	<u>Fy</u>	<u>Fz</u>	<u>Tph</u>	<u>Tth</u>	<u>Tps</u>
0.0	0.0	0.0	0.0	0.0	0.0

**Fig. 4.25** – Bushing Stiffness, Damping, and Force Data

Bushing #	Car /	Component	Car /	Component	X	Y	Z	X1	Y1	Z1	X2	Y2	Z2
1	1	0	1	1	-4.32	0.0	-2.0	0.0	0.0	0.0	0.0	0.0	0.1
2	1	0	1	2	4.32	0.0	-2.0	0.0	0.0	0.0	0.0	0.0	0.1
3	2	0	2	1	-4.32	0.0	-2.0	0.0	0.0	0.0	0.0	0.0	0.1
4	2	0	2	2	4.32	0.0	-2.0	0.0	0.0	0.0	0.0	0.0	0.1
5	3	0	3	1	-4.32	0.0	-2.0	0.0	0.0	0.0	0.0	0.0	0.1
6	3	0	3	2	4.32	0.0	-2.0	0.0	0.0	0.0	0.0	0.0	0.1
7	4	0	4	1	-4.32	0.0	-2.0	0.0	0.0	0.0	0.0	0.0	0.1
8	4	0	4	2	4.32	0.0	-2.0	0.0	0.0	0.0	0.0	0.0	0.1
9	5	0	5	1	-7.131	0.0	-2.0	0.0	0.0	0.0	0.0	0.0	0.1
10	5	0	5	2	-5.061	0.0	-2.0	0.0	0.0	0.0	0.0	0.0	0.1
11	5	0	5	1	5.061	0.0	-2.0	0.0	0.0	0.0	0.0	0.0	0.1
12	5	0	5	2	7.131	0.0	-2.0	0.0	0.0	0.0	0.0	0.0	0.1
13	6	0	6	1	-4.32	0.0	-2.0	0.0	0.0	0.0	0.0	0.0	0.1
14	6	0	6	2	4.32	0.0	-2.0	0.0	0.0	0.0	0.0	0.0	0.1
15	7	0	7	1	-4.32	0.0	-2.0	0.0	0.0	0.0	0.0	0.0	0.1
16	7	0	7	2	4.32	0.0	-2.0	0.0	0.0	0.0	0.0	0.0	0.1
17	8	0	8	1	-4.32	0.0	-2.0	0.0	0.0	0.0	0.0	0.0	0.1
18	8	0	8	2	4.32	0.0	-2.0	0.0	0.0	0.0	0.0	0.0	0.1
19	9	0	9	1	-4.32	0.0	-2.0	0.0	0.0	0.0	0.0	0.0	0.1
20	9	0	9	2	4.32	0.0	-2.0	0.0	0.0	0.0	0.0	0.0	0.1
21	10	0	10	1	-7.131	0.0	-2.0	0.0	0.0	0.0	0.0	0.0	0.1
22	10	0	10	2	-5.061	0.0	-2.0	0.0	0.0	0.0	0.0	0.0	0.1
23	10	0	10	1	5.061	0.0	-2.0	0.0	0.0	0.0	0.0	0.0	0.1
24	10	0	10	2	7.131	0.0	-2.0	0.0	0.0	0.0	0.0	0.0	0.1
25	11	0	11	1	-4.32	0.0	-2.0	0.0	0.0	0.0	0.0	0.0	0.1
26	11	0	11	2	4.32	0.0	-2.0	0.0	0.0	0.0	0.0	0.0	0.1
27	12	0	12	1	-4.32	0.0	-2.0	0.0	0.0	0.0	0.0	0.0	0.1
28	12	0	12	2	4.32	0.0	-2.0	0.0	0.0	0.0	0.0	0.0	0.1
29	13	0	13	1	-4.32	0.0	-2.0	0.0	0.0	0.0	0.0	0.0	0.1
30	13	0	13	2	4.32	0.0	-2.0	0.0	0.0	0.0	0.0	0.0	0.1
31	14	0	14	1	-4.32	0.0	-2.0	0.0	0.0	0.0	0.0	0.0	0.1
32	14	0	14	2	4.32	0.0	-2.0	0.0	0.0	0.0	0.0	0.0	0.1
33	15	0	15	1	-7.131	0.0	-2.0	0.0	0.0	0.0	0.0	0.0	0.1
34	15	0	15	2	-5.061	0.0	-2.0	0.0	0.0	0.0	0.0	0.0	0.1
35	15	0	15	1	5.061	0.0	-2.0	0.0	0.0	0.0	0.0	0.0	0.1
36	15	0	15	2	7.131	0.0	-2.0	0.0	0.0	0.0	0.0	0.0	0.1

**Fig. 4.26** – Bushing Attachment Data for all Example #2 Bushing Elements

**Step 9:** In the *Cars* Tab and *Body* Sub-Tab, set each component of each cars' *S* Initial Velocity to 1.0m/s. Use the Feature Selection Boxes to scroll through each of the three components of the car (0-2) and each of the fifteen cars. It is useful to set a small initial velocity for each body because the program's algorithms sometime encounter errors when divisors are equal to zero which can be a result of the velocity being zero. Fig. 4.27 shows the new *S* Initial Velocity for Car 1 Component 0.

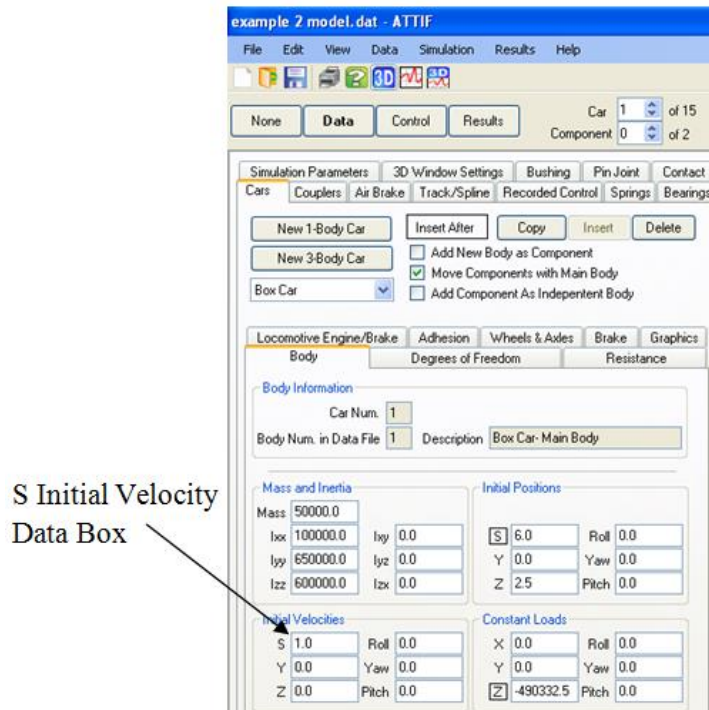


Fig. 4.27 – Body Data for Car 1 Component 0

**Step 10:** Now that the suspension and couplers are in place, the model is nearly complete. For this example we wish to include some acceleration and braking. To do this we will utilize Recorded Control which sets periods of tractive effort and dynamic braking of the locomotives in the consist. First check that Use Tractive Effort and Use Dynamic Braking are checked in the *Locomotive Engine/Braking* Sub-Tab of the *Cars* Tab for Cars 5,10, and 15 (the three locomotives). See the figure below of the *Locomotive Engine/Braking* Sub-Tab.

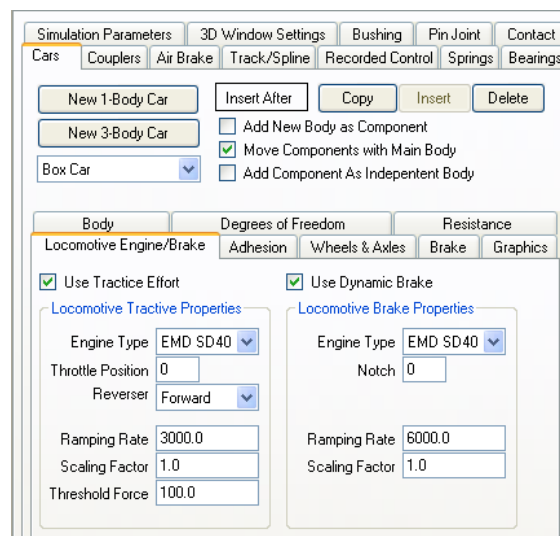
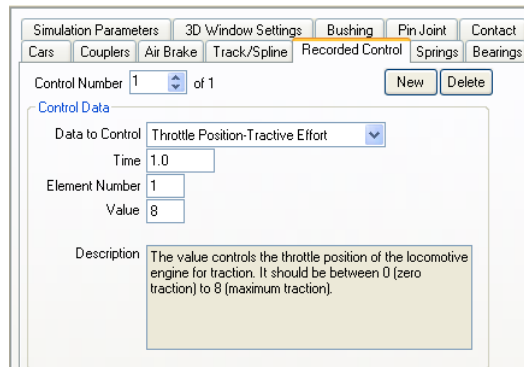


Fig. 4.28 – Locomotive Engine/Brake Sub-Tab

**Step 11:** To add recorded control, go to the *Recorded Control* Tab then click *New* to create the first control. Choose *Throttle Position – Tractive Effort* from the Data to Control Dropdown Menu, *Time 1.0*, *Element Number 1*, and *Value 8*. This will set the tractive effort of locomotive 1 (Car 5) to its maximum level (8) at 1.0s of the simulation. Fig. 4.29 below shows the *Recorded Control* Tab with the first control for this example.



**Fig. 4.29** – Recorded Control Tab

Add the controls in the following table to complete the Recorded Control for this model. Note that with this control the consist will begin accelerating at 1.0s until 240.0s when the tractive effort ceases, and then it will coast until 360.0s when full dynamic braking (256) is activated and the train will decelerate to a stop.

Control #	Data to Control	Time	Element Number	Value
1	Throttle Position - Tractive Effort	1.0	1	8
2	Throttle Position - Tractive Effort	1.0	2	8
3	Throttle Position - Tractive Effort	1.0	3	8
4	Throttle Position - Tractive Effort	240.0	1	0
5	Throttle Position - Tractive Effort	240.0	2	0
6	Throttle Position - Tractive Effort	240.0	3	0
7	Throttle Position - Dynamic Brake	360.0	1	256
8	Throttle Position - Dynamic Brake	360.0	2	256
9	Throttle Position - Dynamic Brake	360.0	3	256

**Fig. 4.30** – Recorded Control Data for Example #2

**Step 12:** We need to change the resistance model for the first and last car in the consist in the *Resistance* Sub-Tab of the *Cars* Tab. *Middle Car* is the default in the Car Location Dropdown Menu. But the lead locomotive (Car 15) and trailing box car (Car 1) are not in between two other railcars, so their aerodynamic models must be properly adjusted. Select *First Car* for Car 15 and *Last Car* for Car 1 from the Car Location Dropdown Menu.

**Step 13:** The train is now complete. Open and load a track (preferably a very long one since our consist will be running for few minutes).



**Step 14:** Check the *Simulation Parameters* Tab in the Data Entry Panel to be sure that everything there is how you would like it. This model contains many more elements than in our last example, so it is likely that the simulation may run very slow depending on the computing power of your computer. Adjust the *Number of Points to Skip* section appropriately (as a suggestion, start with 50).

**Step 15:** Select *Run* from the Simulation Dropdown Menu in the Menu Bar or click the dark blue triangle to begin running the simulation.

#### 4.3 Example #3: 15 Consist including one 7-Body Car with Wheel/Rail Contact

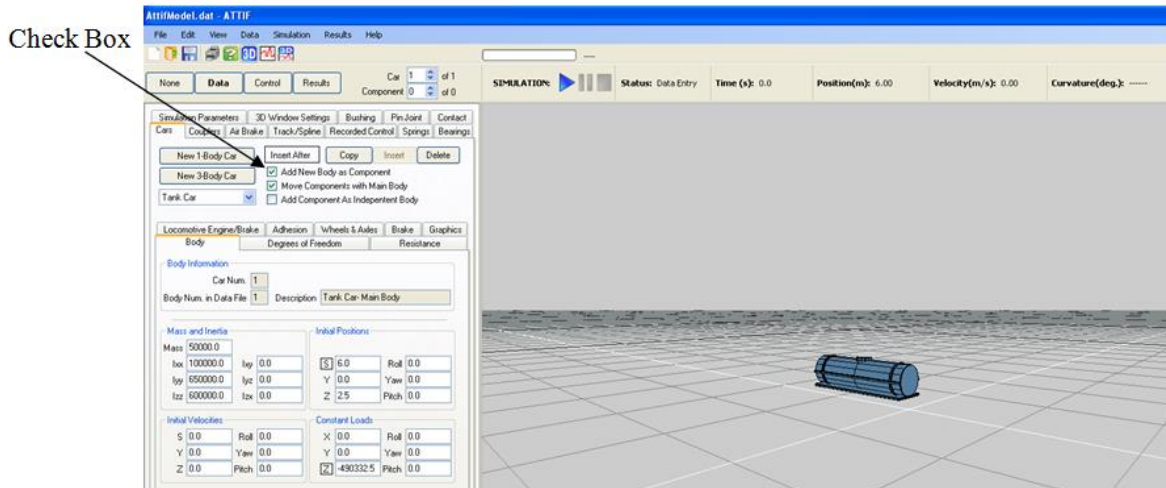
In this third example, wheel/rail contact will be added to a single detailed car within a 15-car consist. The idea is that the detailed contact model can be used to analyze railcars at different positions in the train while keeping the rest of the cars as simple as possible in order to reduce computational time. Please follow the series of steps below to become acquainted with this important feature.

**Step 1:** Open ATTIF and create a new file.

**Step 2:** Select *Tank Car* from the *Vehicle Type Dropdown* Menu and click *New 3-Body Car*. This car will be our detailed car, but first it needs some modification.

**Step 3:** Delete the two bogies (Components 1 and 2 of Car 1) from the tank car and assign the tank car main body (Component 0 of Car 1) to 95m Initial Position in the *S* direction.

**Step 4:** Now we need to add the detailed components of the two bogies we just deleted. Start by checking the *Add New Body as Component* box (see Fig. 4.31 below).



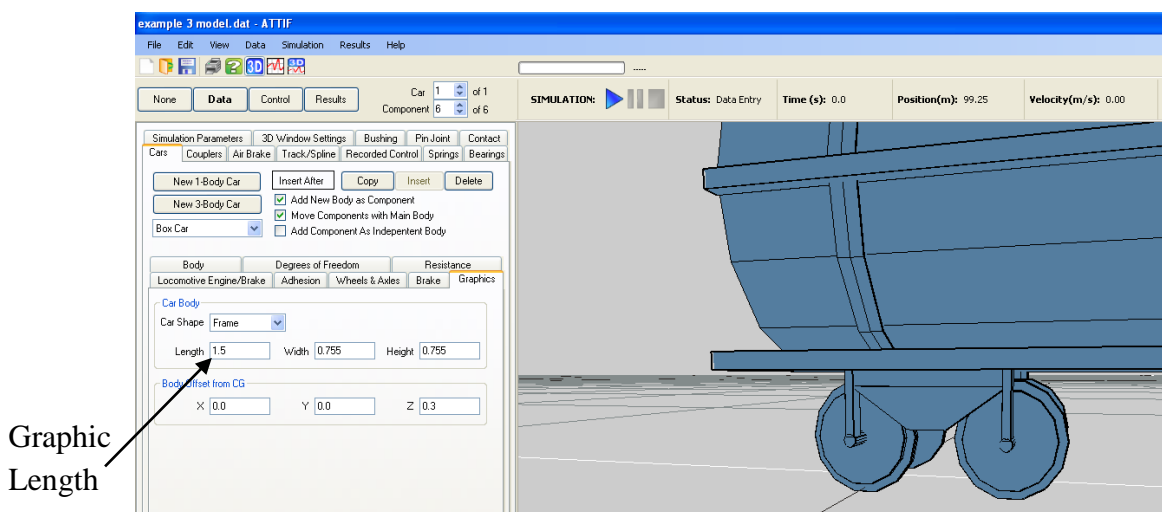
**Fig. 4.31** – Main Body Component of Car 1

**Step 5:** Select *Wheelset* from the *Vehicle Type Dropdown Menu* and click *New 1-Body Car*. This will add the first wheelset of the Detailed Car as Component 1. Set its *S* Initial Position to 90m.

**Step 6:** Repeat Step 5 three more times so you have a total of four wheelsets at 90, 91.5, 98.5, and 100m. The wheelsets should be Components 1-4.

**Step 7:** To add the frames to the model, select *Frame* from the *Vehicle Type Dropdown Menu* and click *New 1-Body Car*. Do this twice and place the first frame (Component 5) at 90.75m and the second (Component 6) at 99.25m.

**Step 8:** Once your frames are in place go to the *Graphics* Sub-Tab for each frame and adjust their lengths to 1.5m. The results of this step can be seen below.



**Fig. 4.32** – Detailed Car Component Graphics

**Step 9:** Our Detailed Car now has all of its components in the proper place. Un-check the *Add New Body as Component* box and select Car 1/Component 6 using the Feature Selection Boxes. Now create the fourteen other vehicles (all 1- Body) listed in the following table. Make sure that when you are adding each new vehicle that you have the previously created car selected before you click *New 1-Body Car* so that they do not become disordered.

Example #3 Consist		
Car #	Vehicle Type	S Initial Position
1	Box Car	6.0
2	Box Car	19.5
3	Box Car	33.0
4	Box Car	46.5
5	Locomotive	64.0
6	Hopper Car	81.5
7	Detailed Car	95.0
8	Hopper Car	108.5
9	Hopper Car	122.0
10	Locomotive	139.5
11	Tank Car	157.0
12	Tank Car	170.5
13	Tank Car	184.0
14	Tank Car	197.5
15	Locomotive	215.0

**Fig. 4.33** – Example #3 Car S-direction Initial Positions

**Step 10:** Add the simple couplers in the next table using the *Couplers* Tab. For coupler numbers 6 and 7, be sure to specify attachment of the coupler to component 0 for all cars. All other default parameters for the simple coupler may be used for this example.

Example #3 Couplers:				
Coupler #	Car I	Car J	Body I x attachment point	Body J x attachment point
1	2	3	6.0	-6.0
2	3	4	6.0	-6.0
3	4	5	6.0	-6.0
4	5	6	6.0	-10.0
5	6	7	10.0	-6.0
6	7	1	6.0	-6.0
7	1	8	6.0	-6.0
8	8	9	6.0	-6.0
9	9	10	6.0	-10.0
10	10	11	10.0	-6.0
11	11	12	6.0	-6.0
12	12	13	6.0	-6.0
13	13	14	6.0	-6.0
14	14	15	6.0	-10.0

**Fig. 4.34** – Coupler Attachment Point Data For Example #3

**Step 11:** Because the Detailed Car has seven individual components each must be connected with suspension elements. For this example we will use a total of 10 bushings and 16 springs. Carefully copy the information from the images below as you create each new element. Any small mistakes made here may result in the failure of your model to run.

Bodies	Couplers	Air Brake	Track/Spline	Recorded Control	Springs	Bearings
Simulation Parameters 3D Window Settings <b>Bushing</b> Pin Joint Contact						
Bushing Number 1 of 10 <span>New</span> <span>Delete</span>						
<b>Body Indices</b>						
Body I 1		Body J 1				
Component 0		Component 5				
<b>Body I Data</b>						
Attachment Point Relative to Body I CG						
X -4.25		Y 0.0		Z -2.2		
<b>Body J Data</b>						
Attachment Point Relative to Body J CG						
X1 0.0		Y1 0.0		Z1 0.0		
X2 0.0		Y2 0.0		Z2 1.0		
<b>Bushing Stiffness</b>						
Kx 5000000.0		Ky 5000000.0		Kz 5000000.0		
Kph 0.0		Kth 0.0		Kps 0.0		
<b>Bushing Damping</b>						
Cx 50000.0		Cy 50000.0		Cz 50000.0		
Cph 0.0		Cth 0.0		Cps 0.0		
<b>Bushing Preload Forces</b>						
Fx 0.0		Fy 0.0		Fz 0.0		
Tph 0.0		Tth 0.0		Tps 0.0		

Bushing 1 Data

Bodies	Couplers	Air Brake	Track/Spline	Recorded Control	Springs	Bearings
Simulation Parameters 3D Window Settings <b>Bushing</b> Pin Joint Contact						
Bushing Number 2 of 10 <span>New</span> <span>Delete</span>						
<b>Body Indices</b>						
Body I 1		Body J 1				
Component 0		Component 6				
<b>Body I Data</b>						
Attachment Point Relative to Body I CG						
X 4.25		Y 0.0		Z -2.2		
<b>Body J Data</b>						
Attachment Point Relative to Body J CG						
X1 0.0		Y1 0.0		Z1 0.0		
X2 0.0		Y2 0.0		Z2 1.0		
<b>Bushing Stiffness</b>						
Kx 5000000.0		Ky 5000000.0		Kz 5000000.0		
Kph 0.0		Kth 0.0		Kps 0.0		
<b>Bushing Damping</b>						
Cx 50000.0		Cy 50000.0		Cz 50000.0		
Cph 0.0		Cth 0.0		Cps 0.0		
<b>Bushing Preload Forces</b>						
Fx 0.0		Fy 0.0		Fz 0.0		
Tph 0.0		Tth 0.0		Tps 0.0		

Bushing 2 Data

Bodies	Couplers	Air Brake	Track/Spline	Recorded Control	Springs	Bearings
Simulation Parameters 3D Window Settings <b>Bushing</b> Pin Joint Contact						
Bushing Number 3 of 10 <span>New</span> <span>Delete</span>						
<b>Body Indices</b>						
Body I 1		Body J 1				
Component 1		Component 5				
<b>Body I Data</b>						
Attachment Point Relative to Body I CG						
X 0.0		Y 1.0287		Z 0.0		
<b>Body J Data</b>						
Attachment Point Relative to Body J CG						
X1 -0.75		Y1 1.0287		Z1 0.0		
X2 -0.75		Y2 1.1287		Z2 0.0		
<b>Bushing Stiffness</b>						
Kx 1000000.0		Ky 1000000.0		Kz 1000000.0		
Kph 0.0		Kth 0.0		Kps 0.0		
<b>Bushing Damping</b>						
Cx 50000.0		Cy 50000.0		Cz 50000.0		
Cph 0.0		Cth 0.0		Cps 0.0		
<b>Bushing Preload Forces</b>						
Fx 0.0		Fy 0.0		Fz 0.0		
Tph 0.0		Tth 0.0		Tps 0.0		

Bushing 3 Data

Bodies	Couplers	Air Brake	Track/Spline	Recorded Control	Springs	Bearings
Simulation Parameters 3D Window Settings <b>Bushing</b> Pin Joint Contact						
Bushing Number 4 of 10 <span>New</span> <span>Delete</span>						
<b>Body Indices</b>						
Body I 1		Body J 1				
Component 1		Component 5				
<b>Body I Data</b>						
Attachment Point Relative to Body I CG						
X 0.0		Y -1.0287		Z 0.0		
<b>Body J Data</b>						
Attachment Point Relative to Body J CG						
X1 -0.75		Y1 -1.0287		Z1 0.0		
X2 -0.75		Y2 -1.1287		Z2 0.0		
<b>Bushing Stiffness</b>						
Kx 1000000.0		Ky 1000000.0		Kz 1000000.0		
Kph 0.0		Kth 0.0		Kps 0.0		
<b>Bushing Damping</b>						
Cx 50000.0		Cy 50000.0		Cz 50000.0		
Cph 0.0		Cth 0.0		Cps 0.0		
<b>Bushing Preload Forces</b>						
Fx 0.0		Fy 0.0		Fz 0.0		
Tph 0.0		Tth 0.0		Tps 0.0		

Bushing 4 Data

Bodies	Couplers	Air Brake	Track/Spline	Recorded Control	Springs	Bearings
Simulation Parameters 3D Window Settings <b>Bushing</b> Pin Joint Contact						
Bushing Number 5 of 10 <span>New</span> <span>Delete</span>						
<b>Body Indices</b>						
Body I 1		Body J 1				
Component 2		Component 5				
<b>Body I Data</b>						
Attachment Point Relative to Body I CG						
X 0.0		Y -1.0287		Z 0.0		
<b>Body J Data</b>						
Attachment Point Relative to Body J CG						
X1 0.75		Y1 -1.0287		Z1 0.0		
X2 0.75		Y2 -1.1287		Z2 0.0		
<b>Bushing Stiffness</b>						
Kx 1000000.0		Ky 1000000.0		Kz 1000000.0		
Kph 0.0		Kth 0.0		Kps 0.0		
<b>Bushing Damping</b>						
Cx 50000.0		Cy 50000.0		Cz 50000.0		
Cph 0.0		Cth 0.0		Cps 0.0		
<b>Bushing Preload Forces</b>						
Fx 0.0		Fy 0.0		Fz 0.0		
Tph 0.0		Tth 0.0		Tps 0.0		

Bushing 5 Data

Bodies	Couplers	Air Brake	Track/Spline	Recorded Control	Springs	Bearings
Simulation Parameters 3D Window Settings <b>Bushing</b> Pin Joint Contact						
Bushing Number 6 of 10 <span>New</span> <span>Delete</span>						
<b>Body Indices</b>						
Body I 1		Body J 1				
Component 2		Component 5				
<b>Body I Data</b>						
Attachment Point Relative to Body I CG						
X 0.0		Y 1.0287		Z 0.0		
<b>Body J Data</b>						
Attachment Point Relative to Body J CG						
X1 0.75		Y1 1.0287		Z1 0.0		
X2 0.75		Y2 1.1287		Z2 0.0		
<b>Bushing Stiffness</b>						
Kx 1000000.0		Ky 1000000.0		Kz 1000000.0		
Kph 0.0		Kth 0.0		Kps 0.0		
<b>Bushing Damping</b>						
Cx 50000.0		Cy 50000.0		Cz 50000.0		
Cph 0.0		Cth 0.0		Cps 0.0		
<b>Bushing Preload Forces</b>						
Fx 0.0		Fy 0.0		Fz 0.0		
Tph 0.0		Tth 0.0		Tps 0.0		

Bushing 6 Data

Bodies	Couplers	Air Brake	Track/Spline	Recorded Control	Springs	Bearings
Simulation Parameters	3D Window Settings	Bushing	Pin Joint	Contact		

Bushing Number 7 of 10 New Delete

**Body Indices**  
 Body I 1 Body J 1  
 Component 3 Component 6

**Body I Data**  
 Attachment Point Relative to Body I CG  
 X 0.0 Y 1.0287 Z 0.0

**Body J Data**  
 Attachment Point Relative to Body J CG  
 X1 -0.75 Y1 1.0287 Z1 0.0  
 X2 -0.75 Y2 1.1287 Z2 0.0

**Bushing Stiffness**  
 Kx 1000000.0 Ky 1000000.0 Kz 1000000.0  
 Kph 0.0 Kth 0.0 Kps 0.0

**Bushing Damping**  
 Cx 50000.0 Cy 50000.0 Cz 50000.0  
 Cph 0.0 Cth 0.0 Cps 0.0

**Bushing Preload Forces**  
 Fx 0.0 Fy 0.0 Fz 0.0  
 Tph 0.0 Tth 0.0 Tps 0.0

Bushing 7 Data

Bodies	Couplers	Air Brake	Track/Spline	Recorded Control	Springs	Bearings
Simulation Parameters	3D Window Settings	Bushing	Pin Joint	Contact		

Bushing Number 8 of 10 New Delete

**Body Indices**  
 Body I 1 Body J 1  
 Component 3 Component 6

**Body I Data**  
 Attachment Point Relative to Body I CG  
 X 0.0 Y -1.0287 Z 0.0

**Body J Data**  
 Attachment Point Relative to Body J CG  
 X1 -0.75 Y1 -1.0287 Z1 0.0  
 X2 -0.75 Y2 -1.1287 Z2 0.0

**Bushing Stiffness**  
 Kx 1000000.0 Ky 1000000.0 Kz 1000000.0  
 Kph 0.0 Kth 0.0 Kps 0.0

**Bushing Damping**  
 Cx 50000.0 Cy 50000.0 Cz 50000.0  
 Cph 0.0 Cth 0.0 Cps 0.0

**Bushing Preload Forces**  
 Fx 0.0 Fy 0.0 Fz 0.0  
 Tph 0.0 Tth 0.0 Tps 0.0

Bushing 8 Data

Bodies	Couplers	Air Brake	Track/Spline	Recorded Control	Springs	Bearings
Simulation Parameters	3D Window Settings	Bushing	Pin Joint	Contact		

Bushing Number 9 of 10 New Delete

**Body Indices**  
 Body I 1 Body J 1  
 Component 4 Component 6

**Body I Data**  
 Attachment Point Relative to Body I CG  
 X 0.0 Y 1.0287 Z 0.0

**Body J Data**  
 Attachment Point Relative to Body J CG  
 X1 0.75 Y1 1.0287 Z1 0.0  
 X2 0.75 Y2 1.1287 Z2 0.0

**Bushing Stiffness**  
 Kx 1000000.0 Ky 1000000.0 Kz 1000000.0  
 Kph 0.0 Kth 0.0 Kps 0.0

**Bushing Damping**  
 Cx 50000.0 Cy 50000.0 Cz 50000.0  
 Cph 0.0 Cth 0.0 Cps 0.0

**Bushing Preload Forces**  
 Fx 0.0 Fy 0.0 Fz 0.0  
 Tph 0.0 Tth 0.0 Tps 0.0

Bushing 9 Data

Bodies	Couplers	Air Brake	Track/Spline	Recorded Control	Springs	Bearings
Simulation Parameters	3D Window Settings	Bushing	Pin Joint	Contact		

Bushing Number 10 of 10 New Delete

**Body Indices**  
 Body I 1 Body J 1  
 Component 4 Component 6

**Body I Data**  
 Attachment Point Relative to Body I CG  
 X 0.0 Y -1.0287 Z 0.0

**Body J Data**  
 Attachment Point Relative to Body J CG  
 X1 0.75 Y1 -1.0287 Z1 0.0  
 X2 0.75 Y2 -1.1287 Z2 0.0

**Bushing Stiffness**  
 Kx 1000000.0 Ky 1000000.0 Kz 1000000.0  
 Kph 0.0 Kth 0.0 Kps 0.0

**Bushing Damping**  
 Cx 50000.0 Cy 50000.0 Cz 50000.0  
 Cph 0.0 Cth 0.0 Cps 0.0

**Bushing Preload Forces**  
 Fx 0.0 Fy 0.0 Fz 0.0  
 Tph 0.0 Tth 0.0 Tps 0.0

Bushing 10 Data

The spring elements can be made using the information from the next table.

Spring #	Body I	Component	Body J	Component	Xi	Yi	Zi	Xi	Yi	Zi	Stiffness	Damping	Length	Force
1	1	0	1	5	-3.5	-0.9287	-2.2	0.75	-1.0287	0.0	10E3	10E5	0.1	0.0
2	1	0	1	5	-3.5	0.9287	-2.2	0.75	1.0287	0.0	10E3	10E5	0.1	0.0
3	1	0	1	5	-5.0	-0.9287	-2.2	-0.75	-1.0287	0.0	10E3	10E5	0.1	0.0
4	1	0	1	5	-5.0	0.9287	-2.2	-0.75	1.0287	0.0	10E3	10E5	0.1	0.0
5	1	0	1	6	5.0	-0.9287	-2.2	0.75	-1.0287	0.0	10E3	10E5	0.1	0.0
6	1	0	1	6	5.0	0.9287	-2.2	0.75	1.0287	0.0	10E3	10E5	0.1	0.0
7	1	0	1	6	3.5	-0.9287	-2.2	-0.75	-1.0287	0.0	10E3	10E5	0.1	0.0
8	1	0	1	6	3.5	0.9287	-2.2	-0.75	1.0287	0.0	10E3	10E5	0.1	0.0
9	1	0	1	6	5.0	1.0287	-2.2	0.75	1.0287	-0.1	10E5	10E5	0.1	0.0
10	1	0	1	6	5.0	-1.0287	-2.2	0.75	-1.0287	-0.1	10E5	10E5	0.1	0.0
11	1	0	1	6	3.5	1.0287	-2.2	-0.75	1.0287	-0.1	10E5	10E5	0.1	0.0
12	1	0	1	6	3.5	-1.0287	-2.2	-0.75	-1.0287	-0.1	10E5	10E5	0.1	0.0
13	1	0	1	5	-3.5	1.0287	-2.2	0.75	1.0287	-0.1	10E5	10E5	0.1	0.0
14	1	0	1	5	-3.5	-1.0287	-2.2	0.75	-1.0287	-0.1	10E5	10E5	0.1	0.0
15	1	0	1	5	-5.0	1.0287	-2.2	-0.75	1.0287	-0.1	10E5	10E5	0.1	0.0
16	1	0	1	5	-5.0	-1.0287	-2.2	-0.75	-1.0287	-0.1	10E5	10E5	0.1	0.0

**Fig. 4.35** – Example #3 Spring Element Data for Detailed Car

**Step 12:** For wheel/rail contact we will need to create a contact point for each wheel of the Detailed Car for a total of eight contacts. The *Contact* Tab in the Data Entry Panel will be utilized for this purpose. Copy the data from the Tab images for each contact point and read the tips below.

Some things to note when creating contact points:

- Each wheelset (components 1-4) will have two contact points (one for each wheel, right and left).
- The right rail is in the negative  $y$  direction from the  $s$ -axis and the left rail is in the positive direction.
- ICSPL, JCSPL, and ICTJP alternate from 1, 2, 2 respectively for the right rail to 3, 3, 4 respectively for the left rail.
- ICREP should start at 1 and increase by one for each new contact point.
- S1 (Wheel) and S2 (Rail) also alternate between right and left for each contact point.
- S1 (Rail) is the  $S$ -direction coordinate of the initial point of contact which is the same as the  $S$  initial position of each wheelset.
- E (Wheel) and E (Rail) are both 21E10.

Bodies	Couplers	Air Brake	Track/Spline	Recorded Control	Springs	Bearings
Simulation Parameters						
3D Window Settings		Bushing		Pin Joint		Contact
Contact Number 1 of 8 <span style="float:right">New Delete</span>						
Contact Body Indices			Body J			
Body I			Rail			
Body # 1						
Component 1						
Contact Parameters						
ICMOD Single Spline		JCMOD Single Spline				
ITWDC Other		TOL 0.003				
ICSPL 1		JCSPL 2				
ICREP 1		ICTJP 2				
Contact Profile						
Surface Parameters						
S1 (Wheel) 0.050310686		S2 (Wheel) 0.0				
S1 (Rail) 90.0		S2 (Rail) 0.054073351				
Coordinate of Wheel Profile Frame origin						
X 0.0		Y -0.735		Z 0.0		
Coordinate of Rail Profile Frame origin						
X 0.0		Y -0.755		Z 0.0		
Distance of Wheel Center From Center of Wheel Set						
D -0.6943						
Contact Creepage						
ICRV Creepage Force		Friction Coef. 0.5				
E (Wheel) 21000000000		E (Rail) 21000000000				
G (Wheel) 80000000000		G (Rail) 80000000000				
P (Wheel) 0.3		P (Rail) 0.3				
RR (Wheel) 0.0		RR (Rail) 0.0				
RT (Wheel) 0.0		RT (Rail) 0.0				
Flang Fric. Coef. 0.5		Psi 1.5708				

Contact #1 Data

Bodies	Couplers	Air Brake	Track/Spline	Recorded Control	Springs	Bearings
Simulation Parameters						
3D Window Settings		Bushing		Pin Joint		Contact
Contact Number 2 of 8 <span style="float:right">New Delete</span>						
Contact Body Indices			Body J			
Body I			Rail			
Body # 1						
Component 1						
Contact Parameters						
ICMOD Single Spline		JCMOD Single Spline				
ITWDC Other		TOL 0.003				
ICSPL 3		JCSPL 4				
ICREP 2		ICTJP 3				
Contact Profile						
Surface Parameters						
S1 (Wheel) 0.104566468		S2 (Wheel) 0.0				
S1 (Rail) 90.0		S2 (Rail) 0.047050111				
Coordinate of Wheel Profile Frame origin						
X 0.0		Y 0.735		Z 0.0		
Coordinate of Rail Profile Frame origin						
X 0.0		Y 0.755		Z 0.0		
Distance of Wheel Center From Center of Wheel Set						
D 0.6943						
Contact Creepage						
ICRV Creepage Force		Friction Coef. 0.5				
E (Wheel) 21000000000		E (Rail) 21000000000				
G (Wheel) 80000000000		G (Rail) 80000000000				
P (Wheel) 0.3		P (Rail) 0.3				
RR (Wheel) 0.0		RR (Rail) 0.0				
RT (Wheel) 0.0		RT (Rail) 0.0				
Flang Fric. Coef. 0.5		Psi 1.5708				

Contact #2 Data

Bodies	Couplers	Air Brake	Track/Spline	Recorded Control	Springs	Bearings
Simulation Parameters						
3D Window Settings		Bushing		Pin Joint		Contact
Contact Number 3 of 8 <span style="float:right">New Delete</span>						
Contact Body Indices			Body J			
Body I			Rail			
Body # 1						
Component 2						
Contact Parameters						
ICMOD Single Spline		JCMOD Single Spline				
ITWDC Other		TOL 0.003				
ICSPL 1		JCSPL 2				
ICREP 3		ICTJP 2				
Contact Profile						
Surface Parameters						
S1 (Wheel) 0.050310686		S2 (Wheel) 0.0				
S1 (Rail) 91.5		S2 (Rail) 0.054073351				
Coordinate of Wheel Profile Frame origin						
X 0.0		Y -0.735		Z 0.0		
Coordinate of Rail Profile Frame origin						
X 0.0		Y -0.755		Z 0.0		
Distance of Wheel Center From Center of Wheel Set						
D -0.6943						
Contact Creepage						
ICRV Creepage Force		Friction Coef. 0.5				
E (Wheel) 21000000000		E (Rail) 21000000000				
G (Wheel) 80000000000		G (Rail) 80000000000				
P (Wheel) 0.3		P (Rail) 0.3				
RR (Wheel) 0.0		RR (Rail) 0.0				
RT (Wheel) 0.0		RT (Rail) 0.0				
Flang Fric. Coef. 0.5		Psi 1.5708				

Contact #3 Data

Bodies	Couplers	Air Brake	Track/Spline	Recorded Control	Springs	Bearings
Simulation Parameters						
3D Window Settings		Bushing		Pin Joint		Contact
Contact Number 4 of 8 <span style="float:right">New Delete</span>						
Contact Body Indices			Body J			
Body I			Rail			
Body # 1						
Component 2						
Contact Parameters						
ICMOD Single Spline		JCMOD Single Spline				
ITWDC Other		TOL 0.003				
ICSPL 3		JCSPL 4				
ICREP 4		ICTJP 3				
Contact Profile						
Surface Parameters						
S1 (Wheel) 0.104566468		S2 (Wheel) 0.0				
S1 (Rail) 91.5		S2 (Rail) 0.047050111				
Coordinate of Wheel Profile Frame origin						
X 0.0		Y 0.735		Z 0.0		
Coordinate of Rail Profile Frame origin						
X 0.0		Y 0.755		Z 0.0		
Distance of Wheel Center From Center of Wheel Set						
D 0.6943						
Contact Creepage						
ICRV Creepage Force		Friction Coef. 0.5				
E (Wheel) 21000000000		E (Rail) 21000000000				
G (Wheel) 80000000000		G (Rail) 80000000000				
P (Wheel) 0.3		P (Rail) 0.3				
RR (Wheel) 0.0		RR (Rail) 0.0				
RT (Wheel) 0.0		RT (Rail) 0.0				
Flang Fric. Coef. 0.5		Psi 1.5708				

Contact #4 Data

Bodies	Couplers	Air Brake	Track/Spline	Recorded Control	Springs	Bearings
Simulation Parameters		3D Window Settings		Bushing	Pin Joint	Contact
Contact Number 5 of 8 <span>New</span> <span>Delete</span>						
<b>Contact Body Indices</b>						
Body I			Body J			
Body # 1			Rail			
Component 3						
<b>Contact Parameters</b>						
ICMOD Single Spline		JCMOD Single Spline				
ITWOC Other		TOL 0.003				
ICSPL 1		JCSPL 2				
ICREP 5		ICTJP 2				
<b>Contact Profile</b>						
Surface Parameters						
S1 (Wheel) 0.050310686		S2 (Wheel) 0.0				
S1 (Rail) 98.5		S2 (Rail) 0.054073351				
Coordinate of Wheel Profile Frame origin						
X 0.0		Y -0.735		Z 0.0		
Coordinate of Rail Profile Frame origin						
X 0.0		Y -0.755		Z 0.0		
Distance of Wheel Center From Center of Wheel Set						
D -0.6943						
<b>Contact Creepage</b>						
ICRV Creepage Force		Friction Coef. 0.5				
E (Wheel) 2100000000		E (Rail) 2100000000				
G (Wheel) 8000000000		G (Rail) 8000000000				
P (Wheel) 0.3		P (Rail) 0.3				
RR (Wheel) 0.0		RR (Rail) 0.0				
RT (Wheel) 0.0		RT (Rail) 0.0				
Flang Fric. Coef. 0.5		Psi 1.5708				

Contact #5 Data

Bodies	Couplers	Air Brake	Track/Spline	Recorded Control	Springs	Bearings
Simulation Parameters		3D Window Settings		Bushing	Pin Joint	Contact
Contact Number 6 of 8 <span>New</span> <span>Delete</span>						
<b>Contact Body Indices</b>						
Body I			Body J			
Body # 1			Rail			
Component 3						
<b>Contact Parameters</b>						
ICMOD Single Spline		JCMOD Single Spline				
ITWOC Other		TOL 0.003				
ICSPL 3		JCSPL 4				
ICREP 6		ICTJP 3				
<b>Contact Profile</b>						
Surface Parameters						
S1 (Wheel) 0.104566468		S2 (Wheel) 0.0				
S1 (Rail) 98.5		S2 (Rail) 0.047050111				
Coordinate of Wheel Profile Frame origin						
X 0.0		Y 0.735		Z 0.0		
Coordinate of Rail Profile Frame origin						
X 0.0		Y 0.755		Z 0.0		
Distance of Wheel Center From Center of Wheel Set						
D 0.6943						
<b>Contact Creepage</b>						
ICRV Creepage Force		Friction Coef. 0.5				
E (Wheel) 2100000000		E (Rail) 2100000000				
G (Wheel) 8000000000		G (Rail) 8000000000				
P (Wheel) 0.3		P (Rail) 0.3				
RR (Wheel) 0.0		RR (Rail) 0.0				
RT (Wheel) 0.0		RT (Rail) 0.0				
Flang Fric. Coef. 0.5		Psi 1.5708				

Contact #6 Data

Bodies	Couplers	Air Brake	Track/Spline	Recorded Control	Springs	Bearings
Simulation Parameters		3D Window Settings		Bushing	Pin Joint	Contact
Contact Number 7 of 8 <span>New</span> <span>Delete</span>						
<b>Contact Body Indices</b>						
Body I			Body J			
Body # 1			Rail			
Component 4						
<b>Contact Parameters</b>						
ICMOD Single Spline		JCMOD Single Spline				
ITWOC Other		TOL 0.003				
ICSPL 1		JCSPL 2				
ICREP 7		ICTJP 2				
<b>Contact Profile</b>						
Surface Parameters						
S1 (Wheel) 0.050310686		S2 (Wheel) 0.0				
S1 (Rail) 100.0		S2 (Rail) 0.054073351				
Coordinate of Wheel Profile Frame origin						
X 0.0		Y -0.735		Z 0.0		
Coordinate of Rail Profile Frame origin						
X 0.0		Y -0.755		Z 0.0		
Distance of Wheel Center From Center of Wheel Set						
D -0.6943						
<b>Contact Creepage</b>						
ICRV Creepage Force		Friction Coef. 0.5				
E (Wheel) 2100000000		E (Rail) 2100000000				
G (Wheel) 8000000000		G (Rail) 8000000000				
P (Wheel) 0.3		P (Rail) 0.3				
RR (Wheel) 0.0		RR (Rail) 0.0				
RT (Wheel) 0.0		RT (Rail) 0.0				
Flang Fric. Coef. 0.5		Psi 1.5708				

Contact #7 Data

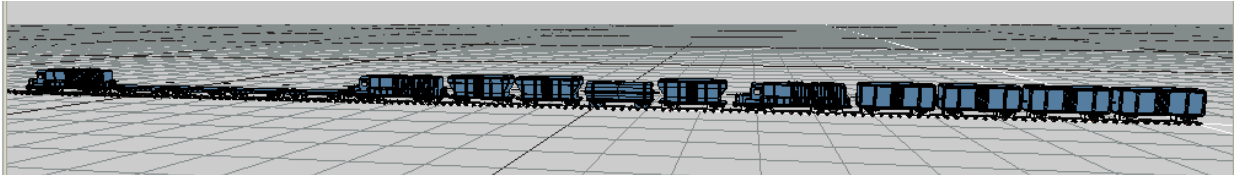
Bodies	Couplers	Air Brake	Track/Spline	Recorded Control	Springs	Bearings
Simulation Parameters		3D Window Settings		Bushing	Pin Joint	Contact
Contact Number 8 of 8 <span>New</span> <span>Delete</span>						
<b>Contact Body Indices</b>						
Body I			Body J			
Body # 1			Rail			
Component 4						
<b>Contact Parameters</b>						
ICMOD Single Spline		JCMOD Single Spline				
ITWOC Other		TOL 0.003				
ICSPL 3		JCSPL 4				
ICREP 8		ICTJP 3				
<b>Contact Profile</b>						
Surface Parameters						
S1 (Wheel) 0.104566468		S2 (Wheel) 0.0				
S1 (Rail) 100.0		S2 (Rail) 0.047050111				
Coordinate of Wheel Profile Frame origin						
X 0.0		Y 0.735		Z 0.0		
Coordinate of Rail Profile Frame origin						
X 0.0		Y 0.755		Z 0.0		
Distance of Wheel Center From Center of Wheel Set						
D 0.6943						
<b>Contact Creepage</b>						
ICRV Creepage Force		Friction Coef. 0.5				
E (Wheel) 2100000000		E (Rail) 2100000000				
G (Wheel) 8000000000		G (Rail) 8000000000				
P (Wheel) 0.3		P (Rail) 0.3				
RR (Wheel) 0.0		RR (Rail) 0.0				
RT (Wheel) 0.0		RT (Rail) 0.0				
Flang Fric. Coef. 0.5		Psi 1.5708				

Contact #8 Data



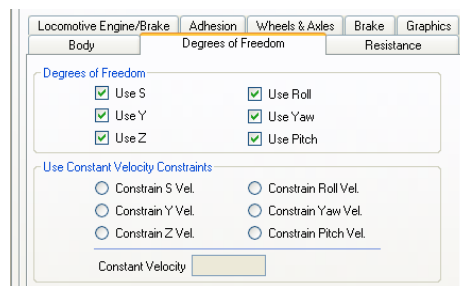
**Step 13:** Assign each railcar an *S* initial velocity of 16.976m/s. Do not forget to specify this velocity for each of the seven components of the Detailed Car (Car 1).

**Step 14:** Check the *Resistance* Sub-Tab for Car 2 and Car 15 as their positions should be assigned as *Last Car* and *First Car*, respectively, from the *Car Location Dropdown* Menu.



**Fig. 4.36** – Example #3 Consist Graphic

**Step 15:** Determine which degrees of freedom you would like for each of the Detailed Car's components. DOFs may be changed in the *Degrees of Freedom* Sub-Tab within the *Cars* Tab. This Sub-Tab can be seen in the image below.



**Fig. 4.37** – Degrees of Freedom Sub-Tab

**Step 16:** Open and Load an appropriate track file in the *Track/Spline* Tab, and enter 3 into the *Track Curve Number* data box.

**Step 17:** Make sure the *Spline Functions* check-box is checked then open the default spline file (ATIFSPL.dat). Enter 4 into the *Number of Spline Functions* data box.

**Step 18:** Save the file (Ctrl + S) and run the simulation (Ctrl + Shift + R).

# APPENDIX

## General Data File

```
AMS-Mode
0
[Needs to be zero]
=====
2-Vehicle ATTIF Model
[This block is irrelevant, but must include one line of text]
=====
3
Spatial-Analysis
[This block is irrelevant, but must include two lines of text]
=====
3
Number-of-the-System-Degrees-of-Freedom
[This block is irrelevant, but must include two lines of text]
=====
6      0      1      0      0      0      0      500
0
[DOF]          [NUM]
Initialization-Parameters
[DOF signifies whether the simulation is single degree of freedom per vehicle
(1 = longitudinal direction only) or it is using multiple degrees of freedom
(6 = all six are available, see marker 16). NUM indicates what numerical
integrator to use (0=Adams, 1=Runge-Kutta). The meaning of the remaining
integers is currently unknown.]
=====
6      2
[Marker] [NOE]
Number-of-Bodies
Masses-and-mass-moments-of-inertia-of-the-bodies
Vehicle_2
1      119295      306315      1632850      1536545      0      0
0
[body #]      [mass]      [Ixx]      [Iyy]      [Izz]
[Ixy][Ixz][Iyz]
Locomotive
2      166922      306315      1632850      1536545      0      0
0
Initial-coordinates
Vehicle_2
1      0      0      2.5      0      0      0
[body #]      [X]      [Y]      [Z]      [ $\phi$ ]      [ $\psi$ ]      [ $\theta$ ]
[ $\phi$  = rotation about X axis,  $\psi$  = rotation about Z axis,  $\theta$  = rotation about Y
axis]
Locomotive
2      13.5      0      2.5      0      0      0
Initial-velocities
Vehicle_2
1      0      0      0      0      0      0
[body #]      [dX]      [dY]      [dZ]      [d $\phi$ ]      [d $\psi$ ]      [d $\theta$ ]
Locomotive
2      0      0      0      0      0      0
```

Constant-forces-and-moments-acting-on-the-bodies

Vehicle\_2

1	0	0	-1170284	0	0	0
[body #]	[fX]	[fY]	[fZ]	[mX]	[mY]	[mZ]

Locomotive

2	0	0	-1637504	0	0	0
---	---	---	----------	---	---	---

[Marker is the marker number (i.e. the above block uses INMARK6 subroutine for reading this data). NOE is the number of elements listed in this block of data (i.e. data is being presented for 2 vehicles). Note that Marker and NOE are listed at the beginning of every data block. Although it is not necessary to have, the track can be set as body 1. If this is the case, it needs some arbitrary mass.]

=====  
11

1

Linear-Spring-Damper-Actuator-Elements

Coupler\_10\_9

1	1	2	0	0	0
[j]	[Body ibd]	[Body jbd]	[Not Used]	[Not Used]	[Not Used]
6	0	-1.624	-6	0	-1.624
[Ux-ibd]	[Uy-ibd]	[Uz-ibd]	[Ux-jbd]	[Uy-jbd]	[Uz-jbd]

1000000	10000	1.5	0
[Ks]	[Ca]	[Lo]	[Force]

[This simulates a spring-damper-force element. IBD and JBD refer to the connected vehicles - JBD is in front of IBD WRT the positive X direction. The  $U_i$  dimensions are from the vehicle CG to the element connection point.  $K_s$  is the elastic stiffness of the element.  $C_a$  is the damping of the element.  $L_o$  is the un-deformed vehicle separation distance. Force is the applied force.]

=====  
16

2

Generalized-Coordinate-Constraints

Constraint\_1

1	1	0	1	1	1	1
[j]	[body #]	[X]	[Y]	[Z]	[ $\phi$ ]	[ $\psi$ ]
1						
[ $\theta$ ]						

Constraint\_2

1	2	0	0	1	1	1
[j]	[body #]	[X]	[Y]	[Z]	[ $\phi$ ]	[ $\psi$ ]
1						

[These place positional constraints with respect to (WRT) the trajectory coordinate system. This block is to be used when DOF is specified as 6 in the Initialization Parameters data block. Note that 0=free and 1=constrained.]

=====  
23

1

Constant-Velocity-Constraints

Constraint\_1

1	2	1	2.78
[j]	[body #]	[Coordinate #]	[Velocity]

[This places velocity constraints WRT the trajectory coordinate system.]

=====  
92

2

Wheelset\_Parameters

Vehicle\_2

1	1	4
---	---	---

[j]	[body #]	[Number of Axles]				
0.755	0.4572	5.024	0.00	-2.04	[Axle 1]	
0.755	0.4572	3.296	0.00	-2.04	[Axle 2]	
0.755	0.4572	-3.296	0.00	-2.04	[Axle 3]	
0.755	0.4572	-5.024	0.00	-2.04	[Axle 4]	
0.00	0.00	0.00	0.00	0.00	[Axle 5]	
0.00	0.00	0.00	0.00	0.00	[Axle 6]	

[Width]	[Radius]	[Ux]	[Uy]	[Uz]	
Locomotive					
2	2	6			
0.755	0.4572	8.166	0.00	-2.04	
0.755	0.4572	6.096	0.00	-2.04	
0.755	0.4572	4.026	0.00	-2.04	
0.755	0.4572	-4.026	0.00	-2.04	
0.755	0.4572	-6.096	0.00	-2.04	
0.755	0.4572	-8.166	0.00	-2.04	

[This data locates up to six axles per vehicle. The width is the lateral distance from the axle center to the wheel/rail contact location. The radius is the vertical distance from the axle center to the wheel/rail contact location. The  $U_i$  dimensions are from the vehicle CG to the axle center.]

93 2

Vehicle-Characteristics-For-Resistance

Vehicle\_2

[j]	[body #]	[2= last car,1=first car,0=middle car,3=only one car]			
11.15	6.00	0.00	-0.25	[For the front face]	
[Area]	[Ux]	[Uy]	[Uz]		
11.15	-6.00	0.00	-0.25	[For the rear face]	
Locomotive					
2	2	1			
11.15	10.00	0.00	-0.25		
11.15	-10.00	0.00	-0.25		

[This data locates the front and rear faces of each vehicle for aerodynamic drag considerations. The area is the effective cross sectional area. The  $U_i$  dimensions are from the vehicle CG to the effective area center.]

94 1

Locomotive-Tractive-Effort

Locomotive

[j]	[Body #]	[Loco ID]	[Notch]	[Reverser]
3000	0.5	<del>100</del>		

[Ramp Rate] [scaling factor] ~~[(threshold or ramping rate)]~~

[Loco ID specifies which type of locomotive to use. Notch is the throttle position from 0-8. Reverser controls the direction, -1, 0, or 1. Ramp Rate is the most tractive effort (lb-force) to be increased per second.]

95 1

Locomotive-Dynamic-Braking

Locomotive

[j]	[Body #]	[Loco ID]	[Notch]
6000	0.5		32
[Ramp Rate]	[force fraction]		

[Loco ID specifies which type of locomotive to use. Notch is the dynamic brake position from 0-256 (simulates infinite control). Ramp Rate is the most braking effort (lb-force) to be increased per second.]

```
=====
96          2
Rail_Conditions
Vehicle_2
1           1           0           0
[j]         [Body #]    [Wet Rail] [Sanded Rail]
0.4         0.2         0.1
[Dry u]     [Wet u]     [Sand du]
```

```
Locomotive
2           2           0           0
0.4         0.2         0.1
```

[The Wet Rail and Sanded Rail flags set the rail condition (1=true, 0=false). Dry and Wet u values are coefficients of friction, Sand du is the change due to sand presence.]

```
=====
97          2
Air_Brake_System_Data
Consist
0           2           0
[j]         [ILC]       [E-Brake]
70.0        0.0         0.0         400.0         900.0         254.0
[OPR]       [Po]        [DPR]       [CSR1]       [CSR2]       [COMP CFM]
0.001625   0.003         0.00891    0.003        0.00891     0.00891
[BCP Area] [ARP Area] [BP Area]  [BVP Area]  [EVP Area]  [CVP Area]
560.0
```

```
[Air Temp]
Vehicle_2
1           1
[j]         [Body #]
0.04167    0.04167        83.33         0.579         1.447         0.5788
[Gap]       [DEFo]         [BC K]        [BC Area]     [AR Volume]   [BC Volume]
0.5         10.0           50.0
[COF]       [Rigging]     [BP Length]
```

```
Locomotive
2           2
0.04167    0.04167        83.33         0.579         1.447         0.5788
0.5         10.0           50.0
```

[This block specifies the air brake parameters for the #2 model (most recent). The following is the data for the consist: ILC is what body number controls the air brakes, E\_Brake controls emergency braking (1=on, 0=off), OPR is the nominal operating pressure (psi), Po is the initial system pressure, DPR is the amount to reduce the brake pipe (i.e. pressure reduction to apply the brakes), CSR1&2 are the control signal propagation rates for normal charging/braking and for emergency braking, COMP CFM is the locomotive air compressor capacity in CFM, the (6) area values for the nominal flow areas for the 1. brake cylinder feed pipe, 2. auxiliary reservoir feed pipe, 3. brake pipe, 4. normal braking vent pipe, 5. emergency braking vent pipe, and 6. the brake cylinder vent pipe, and the air temp refers to the nominal air temperature in the system (R).

The following is the data for each vehicle: Gap is the max gap between the brake pad and the wheel (ft), DEFo is the initial deformation of the brake cylinder spring, BC K is the brake cylinder spring stiffness, BC Area is the brake cylinder piston area, the (2) volumes are the dry volumes of the

auxiliary reservoir and the brake cylinder (ft<sup>3</sup>), COF is the coefficient of friction for the brake pad and wheel, Rigging is the leverage ratio for the linkage between the brake cylinder and the brake pad, and the BP Length is the effective length of the brake pipe.]

```

=====
98          1
Vehicle_Coupler_Elements
Coupler_2_1
  1          1          2          10          0
[j]          [Body ibd] [Body jbd]          [Element ID] [Failed]
6.00          0.00          -1.624          -6.00          0.00          -
1.624
[Ux-ibd]          [Uy-ibd]          [Uz-ibd]          [Ux-jbd]          [Uy-jbd]          [Uz-
jbd]
0.0254          1.50          239.70          5.90          0.00
[Slack]          [L0]          [Kc]          [Ka]          [Strength]
[This is for simulating realistic railroad vehicle connections.  IBD and JBD
refer to the connected vehicles - JBD is in front of IBD WRT the positive X
direction.  Element ID specifies the type of coupling element, 0, 1, 10, or
20.  Failed indicates if the vehicles are disconnected (1=true, 0=false).
The Ui dimensions are from the vehicle CG to the element connection point.
Slack is the inherent element slack per vehicle (used for Element ID = 1, 10,
and 20).  L0 is the un-deformed vehicle separation distance.  Kc refers to the
elastic stiffness (1x109) of the vehicle chassis and Kd refers to the
stiffness (1x109) of the drawbar (if used).  Strength specifies the ultimate
breaking strength (1x103) of the coupler knuckle (used for Element ID = 10 and
20).]
=====

```

```

=====
99          2
Recorded_Operational_Control
Control_1
  1          10          1          1          1
[j]          [Time]          [Code]          [Element #]          [Value]
Control_2
  2          20          1          1          2
[This is used for pre-programming the operation control points for a
simulation.  In the future, the graphical interface will record all of the
control changes that the user makes during a particular simulation.  These
control points will then be written to this block of data to allow for the
re-running of a simulation.  Time refers to the simulation time to make the
change.  Code=1 indicates that the throttle notch will be updated, Code=2
indicates that the dynamic brake notch will be updated, Code=3 indicates that
the coupler status will be updated.  Element # refers to which element in the
above data blocks to modify (i.e. for Code=1, a Element #=1 will change the
throttle setting for the first locomotive listed in the marker 94 data
block).  Value indicates what the new value will be.]
=====

```

```

=====
130          1
AIR_BRAKE_MODELS
Air_brake_1
  1          8
[j]          [NOW]
0.01          0.01          1000.00          0.70          137895.1          1.25          0.50          0.50
[Gap]          [L0]          [Kbc]          [Abc]          [ΔP]          [Va]          [Vbc]          [WP u]
0.46          60.00          0.30
[Radius]          [Inertia]          [WR u]
=====

```

[NOW specifies the number of braked wheels on each vehicle. Gap is the maximum gap between the wheel and the brake pad.  $L_0$  is the un-deformed length of the brake cylinder spring.  $K_{bc}$  is the spring stiffness of the brake cylinder.  $A_{bc}$  is the area of the brake cylinder piston.  $\Delta P$  is the brake pipe pressure reduction.  $V_i$  are the volumes of the auxiliary reservoir and of the brake cylinder.  $W P u$  is the coefficient of friction between the wheel and the brake pad. Radius and Inertia are properties of the wheel.  $W R u$  is the coefficient of friction between the wheel and the rail.]

```
=====
131          2
Vehicle_Brakes
Vehicle_2
  1          1          1
[j]          [Body #]    [Not Sure]
0.00         0.00       0.00         0.00
[Ux]         [Uy]        [Uz]         [Not Used]
```

```
Locomotive
  1          2          1
0.00         0.00       0.00         0.00
[The  $U_i$  dimensions are from the vehicle CG to the point of application.]
=====
```

```
  2          1
Adams-Integration-Method
  0          500         0.1
[T0]         [Tf]         [Step]
0.00001      0.0001     0.00001
[Rel]        [Abs]         [Not Used]
[ $T_0$  and  $T_f$  are the starting and ending simulation times. Step is the time step used to print results. Rel and Abs are the relative and absolute convergence tolerances.]
=====
```

```
  9          1
[This block will open the samscrvt.dat file and proceed to read the track data. The second number indicates which rail set(s) to use (i.e. 1 = use center curve data, 2 = use right rail data, and 3 = use left rail data.)]
Curved-Track
=====
```

```
 1000         0
[1000 specifies to stop reading the data file]
End-of-the-Data-File
```

[General Notes:

1. The above data file is an example for a 2-vehicle simulation. Note that some of the above markers should not be used with others (i.e. marker 98 and marker 11 both simulate vehicle connections).
2. Any text in this document that is red, italic, and surrounded by brackets [...] should be considered comments and not used in a real data file.
3. The term "j" is an internal counter that is not used by the subroutines, but that must be there when shown above.
4. All units are assumed to be in metric, unless stated otherwise]

## General Data File – Contact

AMS-Mode

0

*[Needs to be zero]*

=====

ATTIF-MODEL The suspended wheelset

*[This block is irrelevant, but must include one line of text]*

=====

3

Spatial-Analysis

*[This block is irrelevant, but must include two lines of text]*

=====

11

Number-of-the-System-Degrees-of-Freedom

*[This block is irrelevant, but must include two lines of text]*

=====

6

0

0

0

0

0

0

500

0

0.01

*[DOF]*

*[NUM]*

*[CDIS]*

Initialization-Parameters

*[DOF signifies whether the simulation is single degree of freedom per vehicle (1 = longitudinal direction only) or it is using multiple degrees of freedom (6 = all six are available, see marker 16). NUM indicates what numerical integrator to use (0=Adams, 1=Runge-Kutta). CDIS represents the allowable proximity distance between two contact points on each wheel. The meaning of the remaining integers is currently unknown.]*

=====

2

1

Adams-Integration-Method

0

10

0.001

*[T<sub>0</sub>]*

*[T<sub>f</sub>]*

*[Step]*

1E-06

1E-06

1E-06

*[Rel]*

*[Abs]*

*[Tol]*

*[T<sub>0</sub> and T<sub>f</sub> are the starting and ending simulation times. Step is the time step used to print results. Rel and Abs are the relative and absolute convergence tolerances. Tol is the tolerance used in Newton iteration in finding the surface parameters.]*

=====

6

3

*[Marker] [NOE]*

Number-of-Bodies

Masses-and-mass-moments-of-inertia-of-the-bodies

Rail

1

0

0

0

0

0

0

0

*[body #]*

*[mass]*

*[I<sub>xx</sub>]*

*[I<sub>yy</sub>]*

*[I<sub>zz</sub>]*

*[I<sub>xy</sub>] [I<sub>xz</sub>] [I<sub>yz</sub>]*

Wheelset

2

1568

656

168

656

0

0

0

Frame

3

10000

1799

1799

2450

0

0

0 Initial-coordinates

Rail

1

0

0

0

0

0

0

*[body #]*

*[X]*

*[Y]*

*[Z]*

*[φ]*

*[ψ]*

*[θ]*



[ $\phi$  = rotation about X axis,  $\psi$  = rotation about Z axis,  $\theta$  = rotation about Y axis]

```
Wheelset
 2          0          0          0.4566736441      0          0          0
Frame
 3          0          0          0.4566736441      0          0          0
Initial-velocities
Rail
 1          0          0          0          0          0          0
[body #]   [dX]          [dY]          [dZ]          [d $\phi$ ]      [d $\psi$ ]      [d $\theta$ ]
Wheelset
 2          15          1.1          0          0          0
32.85
Frame
 3          15          0          0          0          0          0
```

Constant-forces-and-moments-acting-on-the-bodies

```
Rail
 1          0          0          0          0          0          0
[body #]   [fX]          [fY]          [fZ]          [mX]          [mY]          [mZ]
Wheelset
 2          0          0          -38000      0          0          0
Frame
 3          0          0          0          0          0          0
```

[Marker is the marker number (i.e. the above block uses INMARK6 subroutine for reading this data). NOE is the number of elements listed in this block of data (i.e. data is being presented for 3 bodies). Note that Marker and NOE are listed at the beginning of every data block. Although it is not necessary to have, the track, as this example shows, can be set as body 1. If this is the case, it needs some arbitrary mass.]

```
=====
11          4
Linear-Spring-Damper-Actuator-Elements
Linear_Spring_1
 1          2          3          0          0          0
[j]        [Body ibd]   [Body jbd]   [Not Used]   [Not Used]   [Not Used]
 0          0.9          0          0.1          0.9          0
[Ux-ibd]   [Uy-ibd]          [Uz-ibd]     [Ux-jbd]     [Uy-jbd]     [Uz-
jbd]
13500      1000          0.1          0
[Ks]       [Cd]          [Lo]         [Force]
Linear_Spring_2
 2          2          3          0          0          0
 0          0.9          0          0          1          0
25000      0          0.1          0
Linear_Spring_3
 3          2          3          0          0          0
 0          -0.9          0          0.1          -0.9          0
13500      1000          0.1          0
Linear_Spring_4
 4          2          3          0          0          0
 0          -0.9          0          0          -1          0
25000      0          0.1          0
```

[This simulates a spring-damper-force element. IBD and JBD refer to the connected vehicles - JBD is in front of IBD WRT the positive X direction. The  $U_i$  dimensions are from the vehicle CG to the element connection point.  $K_s$  is the elastic stiffness of the element.  $C_a$  is the damping of the element.

$L_0$  is the un-deformed vehicle separation distance. Force is the applied force.]

```

=====
16          3
Generalized-Coordinate-Constraints
RailGround
 1          1          1          1          1          1          1
1
[j] [body #]      [S]          [Y]          [Z]          [φ]          [ψ]
[θ]
Wheelset
 2          2          0          0          0          0          0
0
Frame
 3          3          0          1          1          1          1
1

```

[These place positional constraints with respect to (WRT) the trajectory coordinate system. This block is to be used when DOF is specified as 6 in the Initialization Parameters data block. Note that 0=free and 1=constrained.]

```

=====
23          1
Constant-Velocity-Constraints
Constraint_1_For_Frame
 1          3          1          15
[j]      [body #] [Coordinate #] [Velocity]
[This places velocity constraints WRT the trajectory coordinate system.]
=====

```

```

=====
44          2
Elastic-Contact-Method-I
Contact_1
 1          2          1          6          8          1          2
1
[j]      [Body ibd] [Body jbd] [ICMOD]      [JCMOD]      [ICSPL]      [JCSPL]
[ICREP]
 5          0          2
[ITWOC] [Not Used] [ICTJP]
0.0183644657245024      0          0          0.0236440460975024
[S1W]      [S2W]          [S1R]          [S2R]
0.5          0.003
[FriCof] [Not Used]
0          -0.735      0          0          0          0
[RXW]      [RYW]      [RZW]      [Not Used] [Not Used] [Not Used]
0          -0.755      0          0          0          0
[RXR]      [RYR]      [RZR]      [Not Used] [Not Used] [Not Used]
0          0          0          0          0          -0.6943
[Not Used] [Not Used] [Not Used] [Not Used] [Not Used] [WCenter]
Contact_2
 2          2          1          6          8          3          4
2
 5          0          3
-0.0183644657245024      0          0          -0.0236440460975024
0.5          0.003
0          0.735      0          0          0          0
0          0.755      0          0          0          0
0          0          0          0          0          0.6943

```

```

NCREP          2
 1             1             1
[j]            [ICRV]        [ICRV]
210000000000  210000000000  800000000000
800000000000
[EW]          [ER]          [GW]          [GR]
0.3           0.3
[PW]          [PR]
0             0             0             0             1.5708          0.5
[Not Used][Not Used] [Not Used] [Not Used]          [Psi]
[FlangeFriCof]
2             1             1
210000000000  210000000000  800000000000
800000000000
0.3           0.3
0             0             0             0             1.5708          0.5
ENDOC         0

```

[End of this marker]

[This block specifies the parameters used for elastic contact. The following is the data for the contact: [j] is the number of contact. [Body ibd] and [Body jbd] are the two bodies having contact; usually the first one is wheelset and the later one is rail. [ICMOD] and [JCMOD] indicate the method that will be used to define the profile of Wheel/Rail respectively and for current version the Spline is the only choice. [ICSPL] and [JCSPL] specified the Spline function number that will be used by Wheel/Rail respectively. [ICREP] is flag used to define the creep force model. [ITWOC] is the method used to evaluate the second point of contact (5=Quasi-Conformal, other values means using one point contact). [ICTJP] specifies which rail space curve will be used to evaluate contact information (1=center line, 2=right rail, 3=left rail).

[S1W] and [S2W] are initial value of lateral and angular wheel surface parameters. [S1R] and [S2R] are initial value of longitudinal and lateral rail surface parameters. [FriCof] is the coefficient of friction of tread. [RXW], [RYW] and [RZW] are the X,Y,Z position of the origin of the surface coordinate system on the wheel WRT the body coordinate system. [RXR], [RYR] and [RZR] are the X,Y,Z position of the origin of the surface coordinate system on the rail WRT the body coordinate system. [Wcenter] is the lateral distance of the wheel center to the wheelset center of gravity.

The following is the data for the creepage: [j] is the number of creepage model. [ICRV] is the creep force model which the user can refer to in the [ICREP]. [EW/R], [GW/R] and [PW/R] are the elastic modulus, shear modulus and Poisson ratio of the Wheel/Rail respectively. [Psi] is the angle between the normal planes that contain the 1/RRW (principle rolling radius of the wheel) and 1/RRR (principle rolling radius of the rail). [FlangeFriCof] is the coefficient of friction of the flange contact.]

```

=====
3             4
Spline-Functions
C:\Sams2000\Applications\ATTIF2000\ATIFSPL.DAT
[This block specifies the directory of spline data used for the profiles of
wheel and rail.]
=====

```

```

9             3

```

*[This block will open the samscrvt.dat file and proceed to read the track data. The second number indicates which rail set(s) to use (i.e. 1 = use center curve data, 2 = use right rail data, and 3 = use left rail data.)]*  
Curved-Track

=====

```
1000      0  
[1000 specifies to stop reading the data file]  
End-of-the-Data-File
```

*[General Notes:*

- 1. The above data file is an example for a suspended wheelset elastic contact simulation.*
- 2. Any text in this document that is red, italic, and surrounded by brackets [...] should be considered comments and not used in a real data file.*
- 3. The term "j" is an internal counter that is not used by the subroutines, but that must be there when shown above.*
- 4. All units are assumed to be SI unit, unless stated otherwise]*