

MAXI PRO

RACING SEMI-AUTOMATIC SWING ARM TYRE CHANGER
DEMONTÉ-PNEUS SEMI-AUTOMATIQUE RACING AVEC BRAS ARTICULÉ

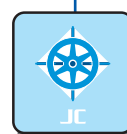

CE

Since 1976



MAXI PRO



STANDARD FEATURES - DONNEES TECHNIQUES

Rim clamping from outside <i>Blocage jante de l'extérieur</i>	10" - 24" *
Rim clamping from inside <i>Blocage jante de l'intérieur</i>	12" - 26" *
Max. tyre diameter <i>Diamètre maxi. roue</i>	1100 mm (43")
Max. tyre width <i>Largeur maxi. roue</i>	390 mm (15")
Bead breaker cylinder force at 10 Bar <i>Force vérin décolleur à 10 Bar</i>	30800 N
Operating pressure <i>Pression de service</i>	10 Bar (145 Psi)
Power supply <i>Alimentation</i>	220V - 1ph - Inverter (STND) 110V - 1ph (OPT)
Motor power <i>Puissance moteur</i>	0,75 kW (2 speed)
Rotation speed <i>Vitesse de rotation</i>	7 - 16 rpm
Pre-set tyre inflating pressure <i>Pression de gonflage maxi.</i>	3,5 Bar (50 Psi)
Net weight <i>Poids net</i>	340 kg

* By adjustable jaws

* Par griffes de blocage réglables

DIMENSIONS - DIMENSIONS

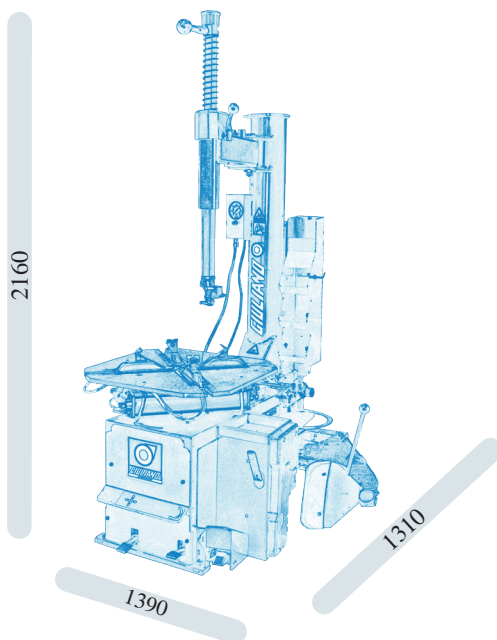

STANDARD ACCESSORIES – ACCESSOIRES STANDARD



For high volume tyre shops.

Pour les ateliers gérant des volumes élevés.

FUNCTIONS - CARACTERISTIQUES

Bead breaker double effect Cylinder Ø 200 mm
Vérin détalonneur de Ø 200 mm à double effet

Reinforced Chassis
Châssis renforcé

Tabletop thickness 14 mm w/adjust. jaws
Plateau centreur ayant une épaisseur de 14 mm avec griffes de blocage réglables

Fitting head designed for both standard and low profiled tyre applications
Tête de montage conçue pour les pneus standards ainsi que pour les pneus à profil rabaisé

Double rotation speed by pedal (220V - 1ph - Inverter)
Double vitesse de rotation par pédale (220V - 1ph - Inverter)

Tyre inflation by pedal (optional)
Dispositif de gonflage par pédale (en option)

Suitable for Help Maxi and Press Arm Maxi (optional)
Possibilité de montage du bras d'appoint Press Arm Maxi et Help Maxi (en option)

Suitable for Tubeless tyre bead seating system (optional)
Système de gonflage Tubeless GUN (en option)

Extra-high tower for extra wide tyres, swinging horizontal arm with Ø 41 mm operating arm
Bras vertical plus élevé pour pneus extra larges, bras horizontal pivotant avec bras porte outil de Ø 41 mm

"Easy Access" extractable pedal box for quick service
Pédalier amovible et facilement accessible pour les opérations d'entretien rapide



DISTRIBUTION RÉAL DUBOIS



Giuliano Industrial S.p.A: Via Guerrieri, 6 - 42015 CORREGGIO (RE) ITALY
Tel. +39 0522 731111 - Telefax +39 0522 633109 - E-mail: info@giuliano-automotive.com
Internet: www.giuliano-automotive.com