

# FIBER OPTICS IN ENG/SNG

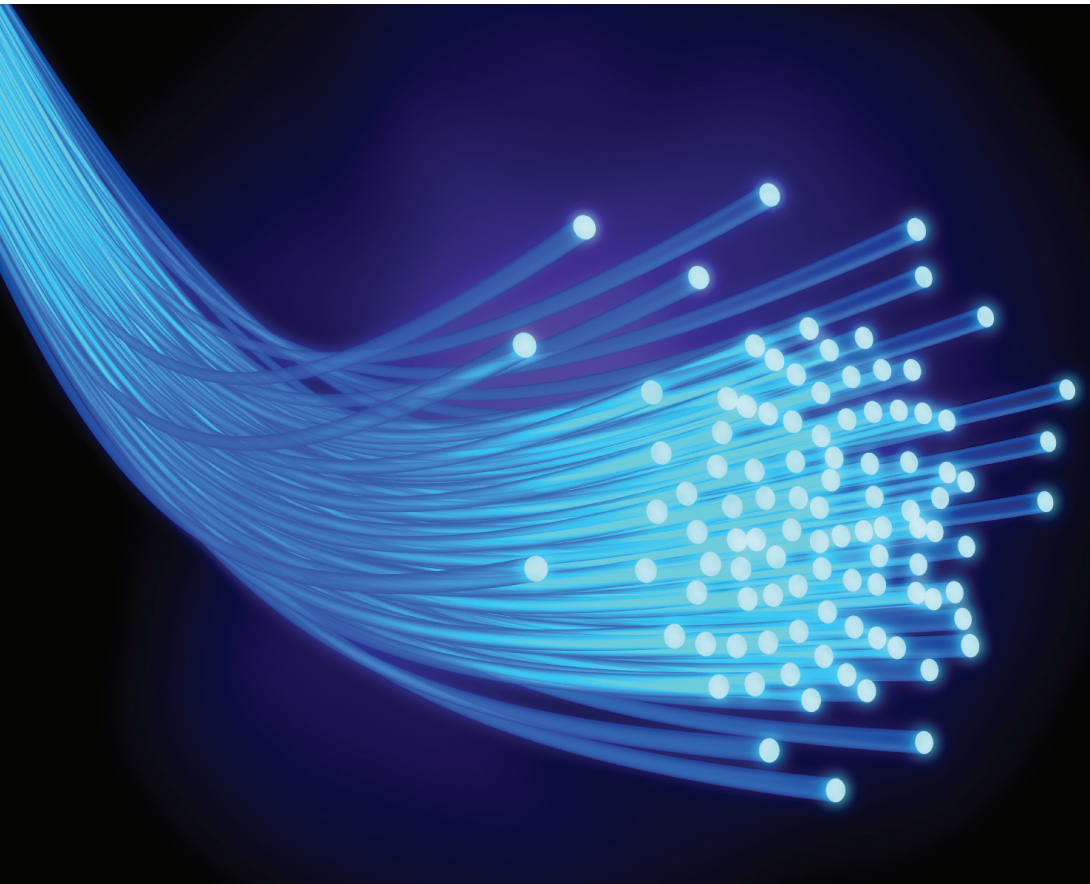

A Guide to Applications,  
System Integration &  
Field Deployment





*Telecast Fiber Systems developed this guide to assist non-engineering broadcast professionals in making critical decisions during the transition to 100% HDTV programming. Not since the transition to color nearly a half century ago has the television broadcast infrastructure experienced such a dramatic shift in technology. Because of the vastly increased bandwidth requirements of HDTV signals, fiber optic technology is certain to play an expanding role in program production at all levels – ENG and SNG included.*

## Introduction

This guide is written for broadcast professionals who are involved in electronic news gathering (ENG) or satellite news gathering (SNG) in any capacity. This includes executives and management at the network and station group level, as well as station managers, news directors, field producers and on-air reporters at the local station. Most engineering personnel will likely be familiar (or at least should be) with the basic technical content; however, this guide may be of value to them as a refresher, and as an update on new developments in fiber optic applications for broadcast.

The following material is divided into four parts.

- **The first part** introduces the basics of fiber optic technology at a level accessible to the non-technical broadcast news professional. It concludes with a summary comparison of fiber optic and copper-based systems. Because theoretical material may not be of interest to all readers, a summary of points relating directly to ENG/SNG is presented at the end of each topic. (“ENG/SNG Perspective”)
- **Part two** reviews the factors involved in transitioning to fiber optics: planning, components required, possible system configurations for basic applications, and alternative approaches to multi-camera systems.
- **Part three** deals with the practical aspects of system deployment, field maintenance and troubleshooting.
- **At the conclusion** is an Appendix which includes a glossary of terms and a comparison chart showing maximum distances allowed for fiber- and copper-based systems at various signal bandwidths.

The main text applies to fiber optic technology, and to generic information regarding systems for ENG/SNG from all manufacturers. Additional information in the sidebars (orange boxes) relates to application-specific solutions provided by Telecast Fiber Systems.

## Fiber Optic Technology Basics

### How Fiber Optic Systems Work

Fiber optic systems carry information between two points by using a light beam that passes through an extremely thin glass fiber strand. The primary purpose of any fiber optic system is to convert electrical signals into light signals, carry those signals over long distances, and then convert them back into electrical signals. Both digital and analog signals may be transmitted over a fiber optic system. Digital signals are carried by converting digital information into very rapid pulses of light. It is technically possible to carry analog signals by modulating the source in response to a varying electrical signal. However, as digital signals are much more robust and reliable, as a practical matter all analog signals are first converted to digital signals prior to optical transmission in all broadcast applications.

### ENG/SNG Perspective

In ENG/SNG applications, fiber optic systems are used to carry audio, video data and intercom signals between a camera location — or multiple camera locations — and the broadcast van during coverage of live news events. Fiber optic systems are preferred to copper cabling when bandwidth requirements are high, when camera locations are a considerable distance from the van, when working in harsh electromagnetic or RF environments, or with combinations of all three.

### Fiber Optic System Components

**The Transmitter** — A fiber optic transmitter converts an electrical signal into an optical signal and propagates the resulting signal along the fiber optic cable. In response to the electronic digital signal, the light source flashes on and off in rapid bursts, reproducing the

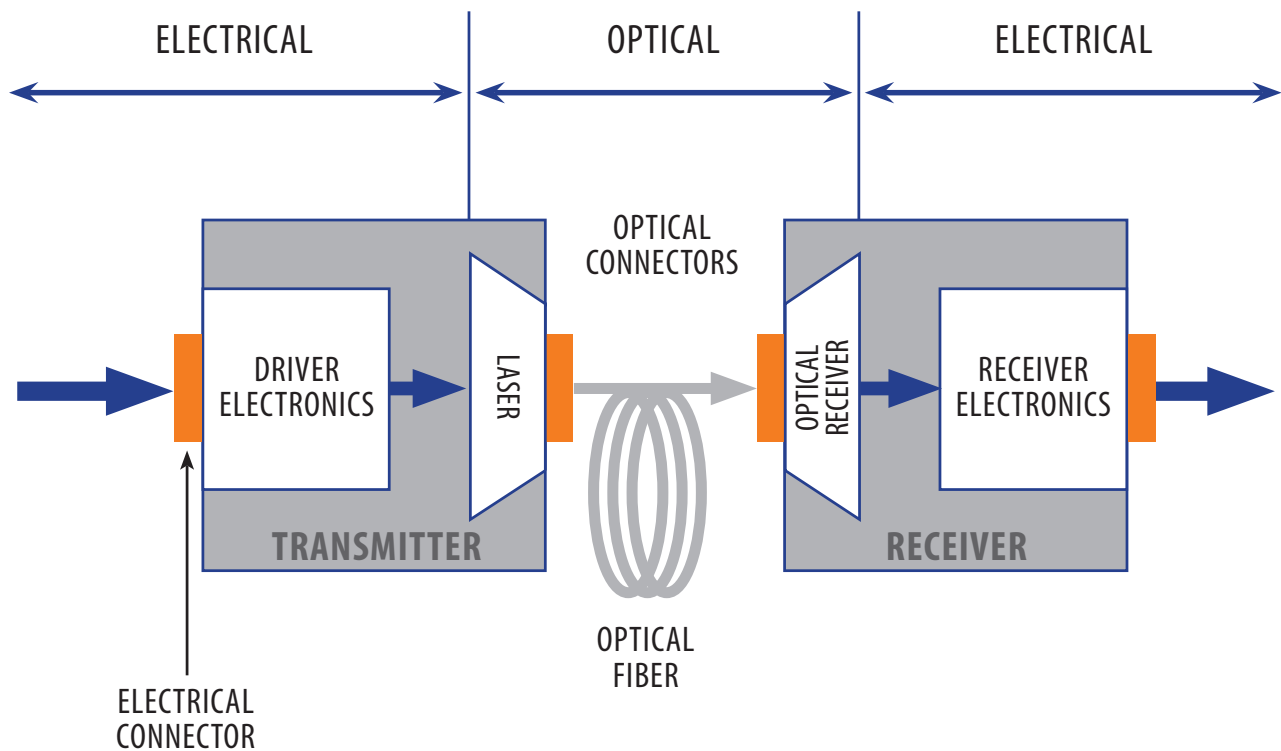

digital zeros and ones. Using a process called optical multiplexing (explained later), multiple digital signals can be transmitted simultaneously on the same strand of fiber optic cable. The light source can be either a light-emitting diode (LED) or a laser; however, nearly all modern broadcast systems now use laser light sources exclusively.

**The Cable** — A fiber optic cable carries the signal-modulated light beam over a strand of transparent fiber that is thinner than a human hair. Though some shorter cables for consumer applications (e.g. Toslink) use plastic fibers, broadcast-quality systems employ glass fibers exclusively as they can be made with higher purity and drawn much thinner — a tenth the diameter of a human hair! The inner transparent glass strand, called the core, is surrounded by a much thicker layer of a different material

called the cladding. Because the cladding material has a different refractive index than the core material, any light striking the cladding is reflected back into the core. As a result, the light propagates down the core of the fiber with very low losses.

A fiber optic cable may have a single core fiber or multiple core fibers (1, 2, 4, 6, 8, or 12). The core and cladding of each fiber is surrounded by a protective plastic buffer material, which is color coded to identify each core in multi-core cables.

The cables used in broadcast field production, called “tactical grade,” are identical to those used by the military in field operations. For strength, tactical grade cables surround the core fibers with extremely strong aramid (“Kevlar”) fibers, and the entire cable is sheathed in a thick polyurethane jacket. The glass fiber cores are surprisingly flexible, and will not break even when the cable is knotted or loosely bent in normal use — or even when run over by a truck!

### OPTICAL FIBER CROSS-SECTION

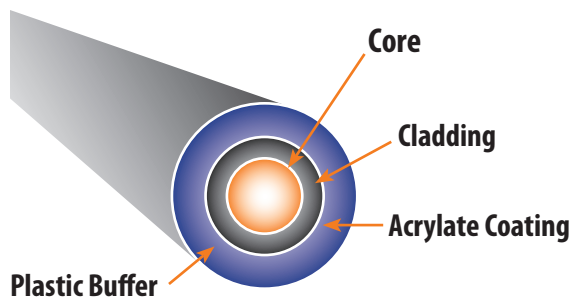

**The Receiver** — The receiver accepts the light beam from the cable, and demodulates the light-modulated signal back to an electrical signal. Note that basic fiber optic receivers and transmitters can be quite small. Matched transmitter/receiver pairs are available that are each only about three inches long, and can be powered by external DC power supplies or even via USB ports.

### “TAC-4” – 4 FIBER CABLE

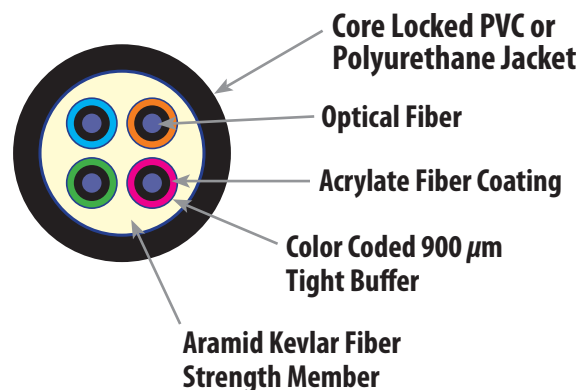

#### ENG/SNG Perspective

Although miniaturized transmitter/receiver pairs can prove handy problem-solvers in specific situations, in most ENG/SNG applications the preferred solution is a transceiver that combines both functions at each end of the fiber. These units accept the multiple audio, video and data signal used in remote production, apply multiplexing, and modulate all signals onto one or more fiber cores contained in a single fiber optic cable.



## Connectors

In fiber optic systems for broadcast, connectors are a critical element that must not be neglected or shortchanged. Because the fiber optic cores are so thin, the two connecting cables must be in precise alignment for the light beam to couple properly from one fiber to the next.

Connectors used to join fiber optic components fall into three broad groups. In one group are connectors designed for permanent indoor installation, such as the push-pull SC, where the

### INSTALLATION-TYPE SINGLE FIBER



connection stays in place for extended periods and environmental conditions

are highly controlled. In applications where disconnection and reconnection is more frequent, but environmental conditions are somewhat controlled (as inside a van), connectors such as the ST type are appropriate. For frequent connections in outdoor field conditions, a “ruggedized” expanded beam type is preferred.

### ENG/SNG Perspective

In field production applications, where devices must be repeatedly connected and disconnected under time pressure, and where contamination from dust and dirt is always a possibility, a different type of “ruggedized” connector is required. Ruggedized connector shells are cast metal or high-grade polymer, dustproof, and use precise locking mechanisms to securely align the fiber cores. Although some field connectors are the physical contact type, a more robust option is use of expanded beam technology. With this type of connector, the light beam is expanded about 2000 times using a relatively large lens (slightly larger than a pinhead), and is captured by a reversed matching lens on the mating connector. The expanded beams are large enough to pass the light beam around any small specs of dust

and dirt that may infiltrate the connector. The lenses are coated to prevent scratching.

### EXPANDED BEAM

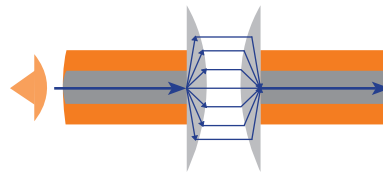

### TELECAST SOLUTION PROFILE:

## MX™ Expanded Beam Connector

The MX™ mini expanded beam optical connector is designed specifically for demanding field teleproduction applications. It provides the proven robustness of expanded beam technology, yet it is much smaller — the hermaphroditic plug is only 21 cm in diameter and 81 cm long — than the widely used PH type connector.

In the MX connector, a precision lens on one plug expands singlemode light beam diameter about 45 times before a matching complementary lens on the mating plug refocuses the light back into the fiber core. This dramatically reduces the negative effects of dust, debris and mechanical vibration. There is no physical contact between lenses to prevent scratching, and each connector includes an integral threaded dust cover.

The MX connector is available in two- and four-fiber versions using the same compact shell. Both jam-nut and flange-mount receptacles are offered.



## Single-Mode and Multimode Fiber

A “mode” refers to the mathematical description of the way light waves propagate through a medium, including the glass core of a fiber optic cable. If the fiber core is thick enough, light rays will enter at the core various angles, reflect off the cladding, and take multiple paths of varying lengths down the core. These multiple paths — or modes — result in different arrival times of the light rays. This in turn creates “modal dispersion” (analogous to distortion in electrical systems) which limits the signal bandwidth and distance capabilities of the thicker multimode fiber type.

Single-mode fiber is much thinner than multimode (9 micron compared to 50 or 62.5 micron), so the light rays essentially travel straight down the fiber strand without “bouncing around” inside the glass core. Because single mode fiber is not subject to modal dispersion, it can carry higher bandwidth signals over much greater distances than multimode fiber.

### ENG/SNG Perspective

Although multimode fiber optic systems are cost-effective and suitable for analog video production, they are not recommended for use with HD-SDI systems because of their limited bandwidth capacity. All future-oriented production systems, including those for ENG/SNG applications, should specify single-mode fiber exclusively, as bandwidth requirements will only increase. Therefore, all systems discussed here assume use of single-mode fiber. Note that, although it is physically possible to mix single mode and multimode cable in the same run (assuming they use the same connectors), this should never be attempted. The fiber cores will be misaligned, and the result will be extremely poor performance — if the system works at all.

### MULTIMODE FIBER

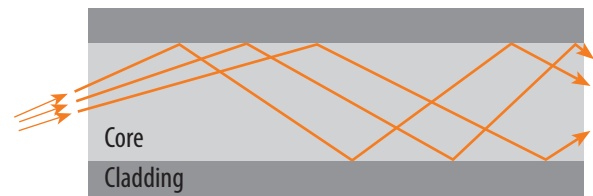

### SINGLE-MODE FIBER

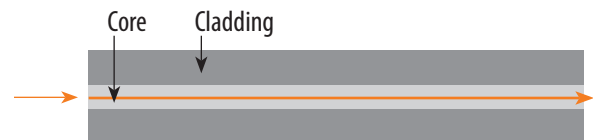

## Light Wavelengths for Fiber Optic Systems

Only certain wavelengths, or “colors,” of light are suited to fiber optic transmission. In today’s broadcast systems, the usable wavelengths are defined as “windows” of +/- 30 nanometers centered on the wavelengths of 1300 nanometers and 1550 nanometers. (A nanometer, abbreviated nm, is one billionth of a meter.) These are both relatively long wavelengths, in the near-infrared region, which makes them ideally suited to use with single-mode fiber. The “window” around the center wavelength allows the use of optical multiplexing, a feature of fiber optic systems which enables them to carry multiple signals over one fiber without interference or crosstalk.

### ENG/SNG Perspective

For field production applications, systems using the 1300 nm wavelength are generally preferred. The bandwidth and distance-carrying capabilities are more than adequate for nearly all SNG/ENG applications, and at 1300 nm the system is resistant to bending losses that might be encountered from inadvertent knots or forced kinks in the cable. The 1550 nm wavelength is somewhat less robust in terms of bending losses, but it can carry very high bandwidth signals over longer distances. A high-power laser transmitter can send a usable HD-SDI signal more than 30 km at the 1550 nm wavelength.

## Multiplexing

Multiplexing is the process through which multiple discrete signals are combined into a single signal for transmission, which can be over a single RF frequency, a copper wire, or a fiber optic cable. Signals may be multiplexed in both the electrical and optical domains. In the electrical domain, digitally-encoded signals may be combined using frequency division multiplexing (FDM) or time division multiplexing (TDM). In the optical domain, two signals may be combined using wavelength division multiplexing (WDM); up to sixteen combined coarse wavelength division multiplexing (CWDM). At the receiver end, the combined signals are de-multiplexed into the original, discrete audio, video, and auxiliary data signals.

### ELECTRONIC MULTIPLEXING

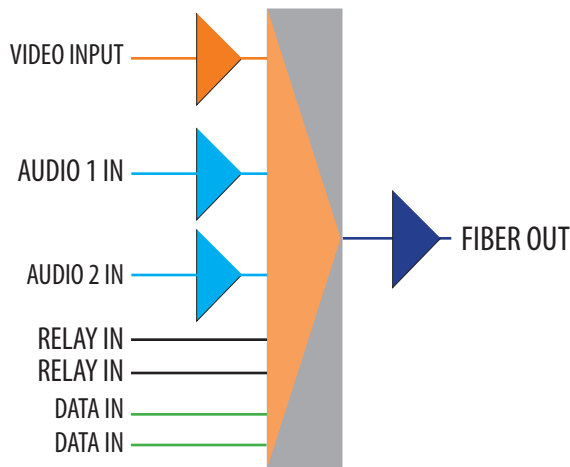

### WAVE DIVISION MULTIPLEXING

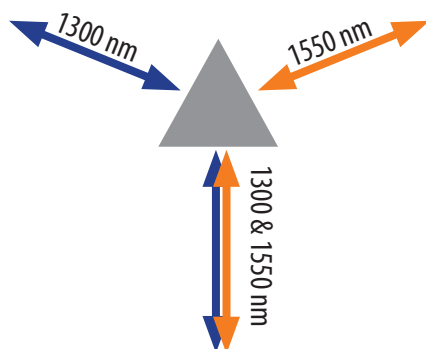

### ENG/SNG Perspective

Multiplexing is a key technology that makes fiber optic systems exceptionally useful in broadcast field production applications. By multiplexing signals into one or two light beams, a single lightweight fiber optic cable can carry more high-bandwidth signals over a longer distance than thick bundles of copper cables weighing many times as much. Most modern fiber optic systems for broadcast employ both electrical and optical multiplexing; in some cases, signals are first multiplexed electrically and then multiplexed again optically before fiber transmission.

## Fiber Optic versus Copper: A Comparison

Following is a brief summary of the major differences between copper-based electrical transmission and fiber optic transmission in typical remote broadcast applications.

**Bandwidth and Distance** — Fiber optic systems are capable of much higher bandwidth than copper-based systems. Using coarse wave division multiplexing (CWDM), one single-mode optical fiber can handle a total bandwidth of more than 70 Gigabits per second (Gbps) and carry it over several kilometers. Single-mode fiber optic systems used in broadcast applications can carry very high-bandwidth signals up to 5 km using a standard laser — more than sufficient for most ENG/SNG applications. Using an optional high-power DFB laser transmitter, effective distances can be extended up to 30 km.

Copper coaxial and triaxial cables can carry high bandwidth signals a short distance, and lower bandwidth signals a longer distance. Some types of high-grade copper coaxial cable are capable of carrying 3.0 Gbps (the equivalent of 1080p HD video) for distances up to 100 m; however, these extremely low-loss cables use a foam dielectric that is susceptible to crushing, making them suitable for studio installation but questionable for ENG/SNG



applications. As a practical matter, use of copper cables for HD-SDI bandwidth signals in even moderately hazardous field deployment is limited to distances of about 100 m.

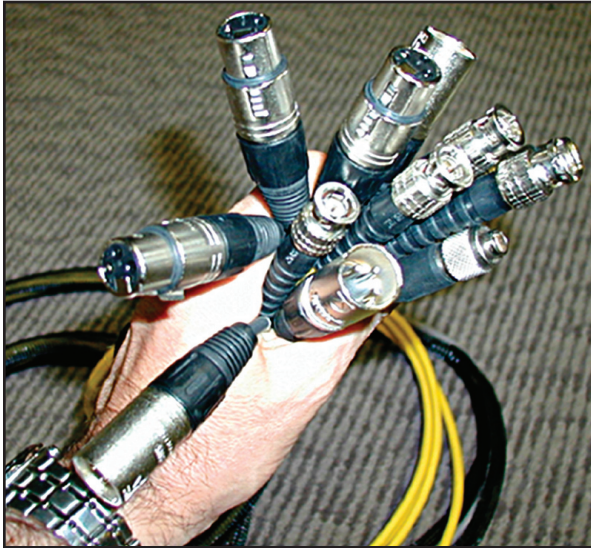

*Bundles and multiple connectors required for copper.*

#### **Multiple Signals (“Signal Agnostic”) —**

Multiple signals of any type — audio, video or data — can be multiplexed on to a single fiber optic cable. The only restriction is total bandwidth available, and in ENG/SNG applications this is rarely an issue with single-mode fiber. With copper-based systems, in contrast, the analog and digital video signals and auxiliary data streams often require use of different cables, each with its own unique connector.

**Bidirectional Communication** — A fiber optic system can transmit signals in both directions simultaneously with no bandwidth limitations. Copper systems can transmit in only one direction at a time over any given signal pair; digital networks can mimic bidirectional communication by rapidly switching between transmit and receive, but this effectively cuts bandwidth in half.

**Cable Weight and Bulk** — Fiber optic cables are extremely small and light compared to the required copper equivalents. A tactical grade

fiber optic cable is about ¼-inch in diameter and weighs about 10 pounds per thousand feet. A typical coaxial cable weighs about four times as much, and the equivalent amount of multiple bundled copper cables needed for an ENG/SNG camera application could weigh more than 20 times as much. Copper would require far bulkier cable reels and, when longer runs are required, more reels and intermediate connections. This equates to more space and weight in the TV truck/OB van or higher shipping costs when moving cable from job to job.

**EMI/RFI Noise and Ground Loops** — Fiber optic communication is inherently immune to all kinds of electromagnetic interference (EMI) and radio frequency interference (RFI). Also, because a fiber optic cable contains no electrical conductors, it cannot contribute to ground loops. All copper cables are susceptible to both EMI and RFI; this can be limited with cable shielding, but shielding adds to bulk and weight. Also, the cables’ metallic conductors and shields can contribute to ground loops.

**Environmental Conditions** — Fiber optic systems are generally immune to interruption by moisture or immersion in water, as there is no electrical current to “short out.” All electrical connections, in contrast, need to be fully moisture protected.

With fiber optic systems, greater attention must be paid to dust and dirt. In field applications, the use of PC (physical contact) connectors requires maintaining contact between the two fiber strands to prevent the intrusion of microscopic particles. Connectors that are regularly mated and unmated in the field are recommended to be of the expanded-beam type that allows light rays to pass around dust particles. Optical connectors of any type should be cleaned routinely.

Dry dust and dirt, in small amounts, rarely cause problems with electrical connections.

## Transitioning to Fiber Optic Systems in ENG/SNG

For many ENG/SNG operations, the integration of fiber optic systems into remote vehicles will take place in conjunction with the overall migration to HD production in all news and other locally produced programming. The timeline and extent of the changeover will vary with specific circumstances, market competition, or budgeting considerations. For example, one news operation may purchase a new fleet of vehicles that are ready-equipped for HD production over fiber. Another may equip one existing vehicle with a fiber optic system for current SD production and transition to HD-SDI at a later date. Yet another may opt for a portable “fly-pack” system that enables remotes over fiber independent of any specific news vehicle.

Regardless of the timeline, everybody involved in the HD transition — station or group management, news directors, and (to a lesser extent) news producers and reporters — should understand the role of fiber optics in ENG/SNG, and become familiar with how fiber optic technology functions in field operations.

### The Role of Fiber Optics in ENG/SNG

Fiber optic systems are used to replace the copper cables — often very large bundles of copper cables — that connect cameras to the news vehicle in live remotes. A single camera live remote often requires as many as seven discrete signals between the truck and camera position:

#### SINGLE CAMERA

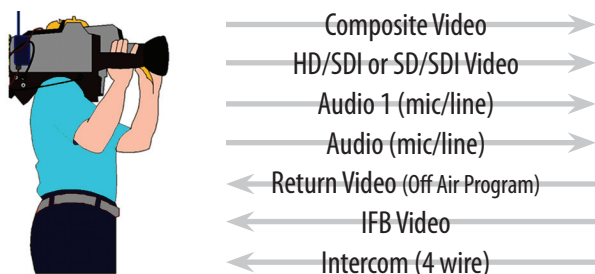

A multi-camera live remote production may require as many as six additional signals between the truck and the camera.

With a fiber optic system, all of the signals can be multiplexed onto one or more optical carriers and transmitted over a single, flexible, lightweight cable.

#### MULTI-CAMERA

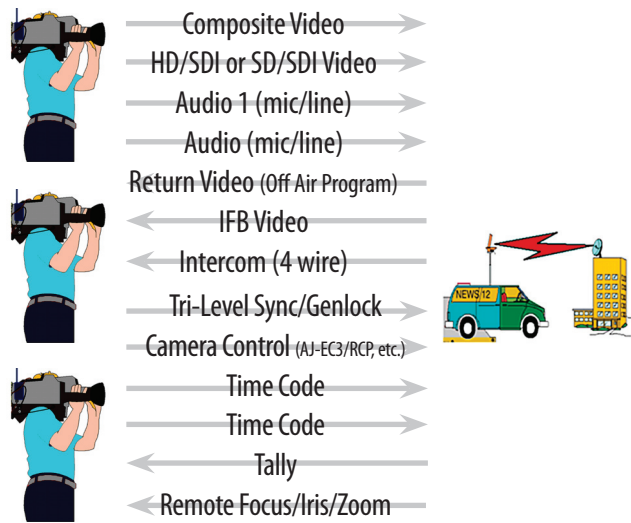

Before the current migration to HD production, this remarkable reduction in cable size and weight was the primary factor driving the adoption of fiber optic systems for ENG/SNG applications. Although copper cables can handle SD bandwidth over distances normally encountered in news remotes, the sheer size of the multiple cable reels required to ensure that “the competition can’t get closer” normally required extreme physical exertion and sometimes increasing news vehicle size. Since HD-SDI bandwidth requires thicker and heavier (and more expensive) low-loss copper cables to maintain signal reach, many news operations are moving to fiber systems rather than upgrading or replacing existing copper cabling.

## Fiber Optic System Elements and Options

**Cables** — Practically all fiber optic systems for broadcast applications will use one of two types of cable: tactical (or “mil-spec”) fiber optic cable or the more specialized SMPTE hybrid cable.

Tactical fiber optic cables are designed for repeated deployment and retrieval outdoors and under extreme environmental conditions. The cables are non-metallic, crush resistant, reinforced with aramid (“Kevlar”) strength fibers, and covered with a tough polyurethane jacket. Typical operating temperatures are -55°C (-67° F) to 85°C (185°F). Cables can be supplied with one to twelve fiber cores; however, with the high bandwidth offered by single-mode transmission, a four-core cable is sufficient for all typical ENG/SNG applications. Although cables with higher core counts are still relatively thin and lightweight, the connectors become much bulkier, and much more difficult to replace. A four-core cable strikes a balance, offering moderate costs with additional cores for multiple cameras or signal redundancy.

SMPTE hybrid is a specialized cable, defined

by the SMPTE 311M standard. It is designed specifically for direct connection between HD-SDI video cameras and the camera control unit (CCU). It comprises two single-mode optical fibers along with four copper conductors, a steel strength member, and shielding. The optical fibers carry the SDI video signal while two copper conductors are used for auxiliary signals and the other two for remote camera powering. The optical properties of the cable are the same as a two-core (duplex) single-mode cable. However, SMPTE fiber is bulkier and significantly heavier than tactical fiber, and it is less robust.

## Fiber Optic System Configurations for ENG/SNG Applications

Fiber optic systems for ENG/SNG can be implemented in two basic configurations: common-“throw-down” systems, or direct fiber-to-camera systems. One type — or both types — may be implemented by a news-gathering operation depending on a number of factors, including prior infrastructure investments, planned pace of HD-SDI transitioning, vehicle capacities

### MUSSEL SHELL FOR ENG – 3 CAMERAS

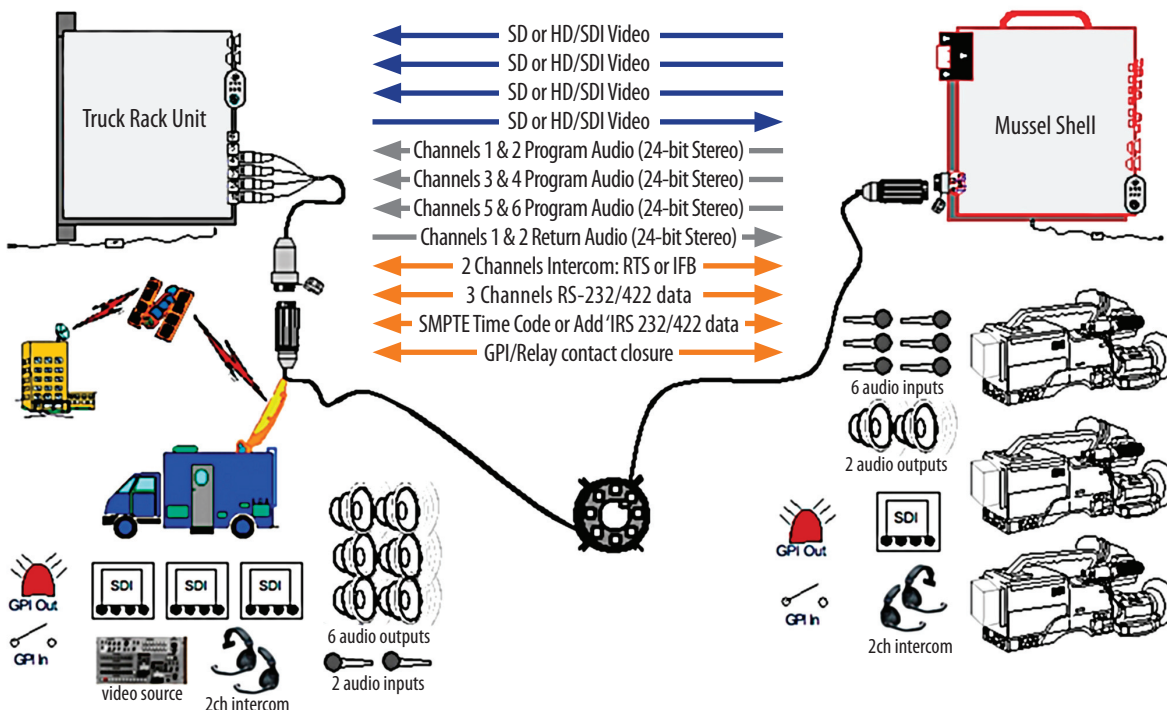



(including multi-camera capabilities), and typical news-gathering assignments.

**Common Point or “Throw-down” Systems —**

This type of system is employed to carry multiple audio, video and data signals between an ENG/SNG truck and a remote location. In extreme cases, such as some high-density urban environments or large-scale outdoor events, the remote camera location could be 3000 feet or more from the remote production truck.

The system comprises three basic components: the base station (mounted in the truck); the remote “throw-down” unit (normally enclosed in a rugged external housing); and the cable and cable reel.

The base station and “throw-down” units are modular in construction, allowing considerable flexibility in configuration of the system for various combinations of video, audio (including intercom) and data signals. The “throw-down” unit is placed close enough to the remote event site to allow connection of cameras and audio sources

using conventional copper cables. The electronics in the “throw-down” are powered by batteries, or from local AC line source.

The common-point system configuration is highly adaptable to news-gathering scenarios that require full multi-camera, live-switched coverage of major events such as courtroom trials, extended political events, or a continuing disaster. The fiber optic “throw-down” extends full multi-camera and multiple audio feed capabilities into places that otherwise might be beyond the reach of totally copper-based system, particularly if HD-SDI capability is required. It also serves as the connection point for a temporary “video village” location, offering monitoring and intercom capabilities for production personnel other than camera operators.

**Direct-to-Camera Systems —** With this type of system, the fiber optic connection extends from the ENG/SNG truck directly to the camera. For fast-breaking news events, particularly when only a single camera will be used, this

**TELECAST SOLUTION PROFILE:**

**Viper™ and Sidewinder™ Portable Fiber Optic Systems**

The Viper and Sidewinder provide flexible, highly modular “throwdown” solutions for ENG/SNG operations with frequent multi-camera remote assignments.

The system provides robust, two-way multi-signal connectivity between an ENG/SNG vehicle and a remote news site. Transmit and receive modules available for all video formats (including HD-SDI), analog and digital audio, intercom, tally, phone, data (RS232/422 and CCU), and Ethernet.

At the camera site, a portable Mussel Shell enclosure houses a UPS plus up to eight transmitter and receiver modules. The fiber connector is a hermaphroditic design with an expanded beam option.

Inside the news vehicle, the Viper enclosure houses the matching TX/RX modules. Protected, permanent connections use simple ST fiber connectors.

Telecast’s unique Sidewinder configuration provides another flexible option, with plug-in modules housed inside the reel hub. Three reel sizes are offered, holding 500 ft (152 m), 1,000 ft (305 m) or 2,000 ft (610 m) of four-core tactical fiber cable.



approach is the preferred option. Compared to the “throw-down” configuration, the direct-to-camera system uses fewer components and requires fewer in-the-field connections. It also eliminates the weight and bulk of copper cable bundles from the “throw-down” to the camera. Compared to all-copper systems, of course, it drastically reduces cable weight and bulk by eliminating copper from the camera all the way back to the truck.

Like the “throw-down” approach, an ENG/SNG direct-to-camera fiber optic system also comprises a vehicle-mounted base station and a cable reel. But instead of a mussel shell it uses a compact, lightweight transceiver that mounts directly on the camera. The most popular systems are designed for use with ENG camcorders, with the transceiver unit sandwiched between the camera body and the battery. (Use with a camcorder has a side benefit: it allows the option of recording “iso” shots for later use in edited stories.) The fiber optic transceiver can be left permanently in place, or attached by the camera operator while en

route to the news scene. When the news crew arrives on site, only two connections are required: between the truck and the fiber reel, and at the other end of the fiber to the camcorder. All the various signals — in both directions — are multiplexed and demultiplexed by the camera transceiver and base station.

In the case of a single-camera assignment with a news team of two (or even one), some of the camera control, intercom and tally signals may not be needed. However, the full complement of camera and auxiliary signals is made available through the transceiver and base station for use in more complex, live-switched multi-camera applications.

Live-switched multi-camera news coverage can be accomplished using one of three possible scenarios with direct-to-camera systems.

In the first scenario, each camcorder uses a separate fiber optic cable to connect directly to an ENG/SNG vehicle. This approach is normally required only in the case of widely separated camera locations at a single event, such as a parade or widely dispersed disaster site.

### THREE CAMERAS, THREE CABLES

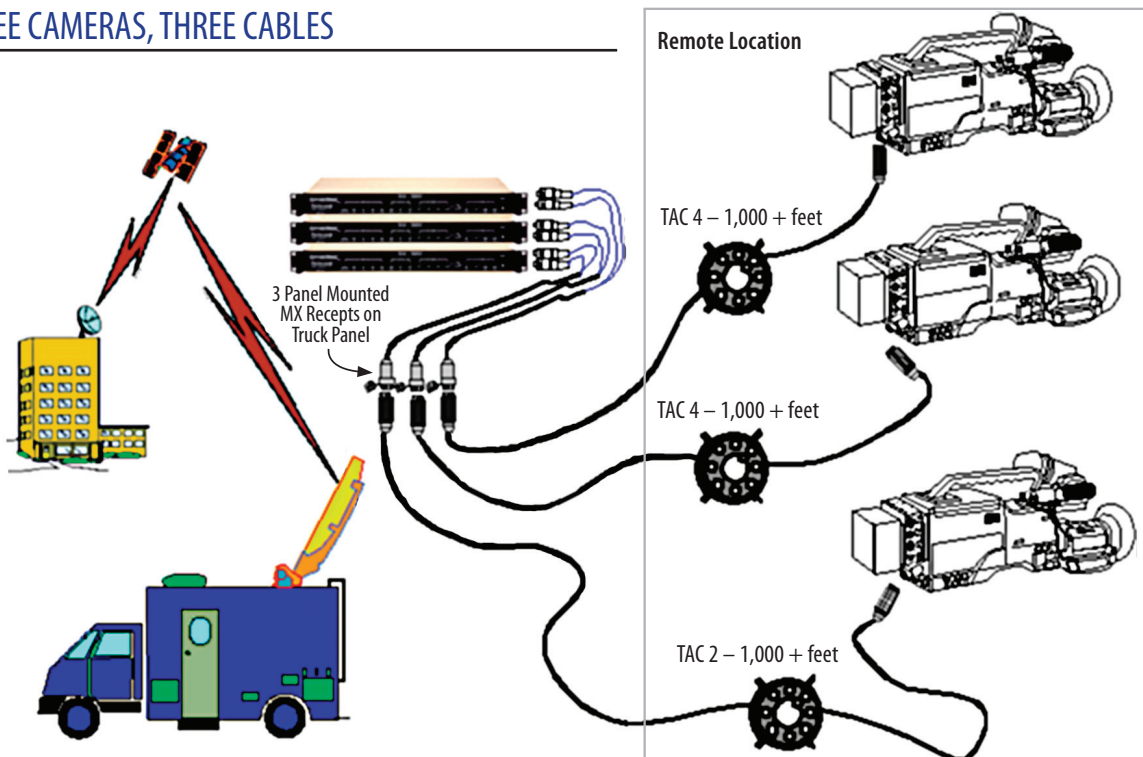



A second scenario is preferred whenever multiple camcorders are deployed in relative proximity to each other, such as in a courtroom or convention center. The shorter duplex fiber optic cables from each camcorder are optically connected to separate corresponding fibers in a longer, four- or six-core cable that connects the event location to the news vehicle.

The third alternative works for stations that have only smaller news vans, each equipped with only a single fiber-optic system base station. In this case, each camcorder operates as an independent source, feeding live signals to its respective news van. The live switching for the multi-camera news event is accomplished back at the studio.

### THREE CAMERAS TO ONE CABLE

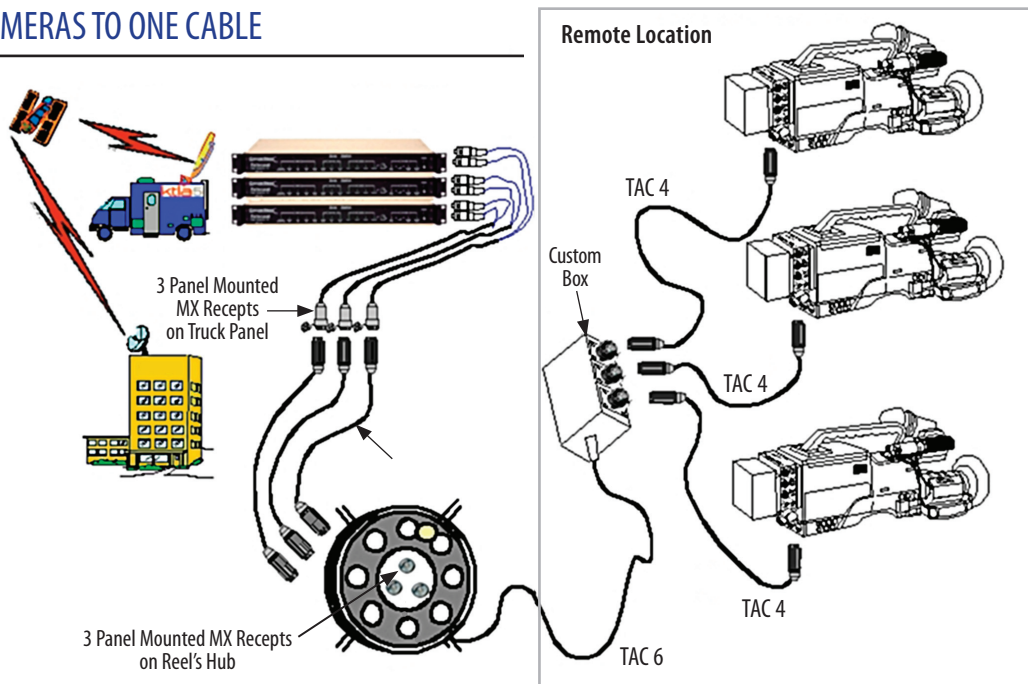

### THREE CAMERAS, THREE VEHICLES

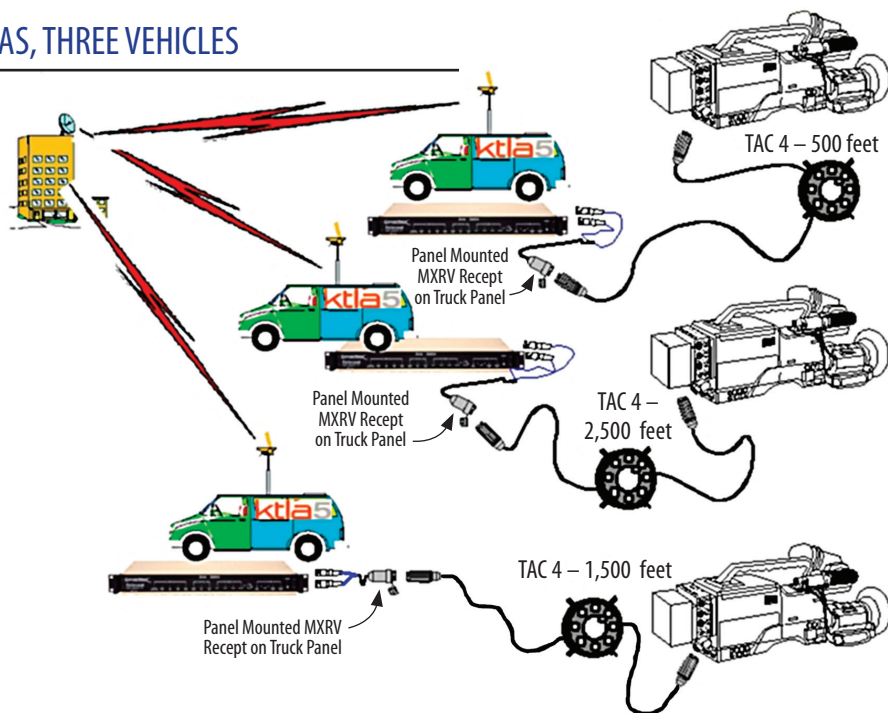

***A Side Note on Tactical versus SMPTE Fiber*** —

The underlying technology of direct-to-camera fiber systems for ENG/SNG is largely the same as that used for large-scale EFP/OB applications, notably major sporting events. In the sports applications, however, most camera positions are pre-determined, ample set-up time is allowed, and cable runs can be fully secured. (Often they are already permanently installed in the arena or stadium.) Also, the duration of sporting events generally precludes battery powering of most cameras.

SMPTE hybrid cable was developed primarily to function in this type of application: it supplies remote power, and the added bulk and weight of the cable's copper components are not critical as rapid deployment normally is not required.

Competitive ENG/SNG applications present a much different — and usually far more

demanding — set of circumstances. Cables must be deployed with extreme rapidity, as even a minute of delay allows a competitor to be “first on-air.” Cables must be lightweight, and require as few field connections as possible. Also, both cables and connectors must be robust, as often the cable pathway cannot be fully secured. The cable may be pulled, dragged, and driven over by vehicles. In contrast to sports, the vast majority of live news assignments involve only a few minutes of on-air time, with any follow-up reports usually separated by intervals of twenty minutes or more. Since batteries are easily sufficient for camera power, remote powering is normally not needed.

For these reasons, tactical fiber optic cable is preferred to SMPTE hybrid cable for nearly all ENG/SNG applications. The cable is lightweight and durable, and the connectors are simple and secure.

**TELECAST SOLUTION PROFILE:****CopperHead Camcorder-Mountable ENG/SNG Transceiver**

CopperHead is a fully integrated system that enables a field camcorder to do double duty as a live remote camera with full fiber optic connectivity and HD capability. The system simultaneously carries both digital (SDI or HD-SDI) and analog (NTSC or PAL) program video, as well as two-way camera control, audio, data, tally/call and intercom signals. In most applications, CopperHead replaces a heavy, ungainly bundle of multiple copper cables with a single, lightweight, and extremely durable fiber optic cable.

The lightweight (1.5 lb) camera unit sandwiches between the camcorder body and the battery using one of three popular battery mount options: Anton/Bauer®, PAG™ or V-mount. The unit connects to the camera with short cables that can be left in place; only a single fiber connection to the base station is required in the field. The connector is Telecast's hermaphroditic MX mini expanded beam. For extended duration shoots, a PowerPlus adapter replaces the battery and connects to a HDX power supply via SMPTE hybrid cable.

The 1U base station incorporates I/O connections for the fiber optic cable as well as all multiplexed video, audio and data signals. It is a transparent “plug and play” device, with no adjustments required in normal operation.





## Staying Competitive with Shrinking Trucks

In recent years, the rapid emergence of HD production has expanded bandwidth requirements. At the same time, the TV news industry has witnessed a significant downsizing of newsgathering vehicle fleets. With the two trends intersecting, many news organizations have found themselves literally “coming up short” in efforts to stay competitive.

Little more than a decade ago, a typical SNG truck was built on a chassis over 30 feet long. It weighed over 15,000 pounds, guzzled gasoline, and in most states you needed a commercial driver’s license to drive it. On the up side, by virtue of sheer size, such a vehicle usually had sufficient payload margins to carry as much as 2000 feet of copper audio and video cable.

Starting in the late 1990s, news operations started thinking smaller. ENG/DSNG hybrids built on the Ford E350 or Dodge Sprinter van platforms became the norm. In recent years, some operations have shifted to SUV platforms, such as the Chevrolet Suburban or Ford Expedition, for their auto uplinks. At a recent trade show, a prominent uplink manufacturer even showed a Mini-Cooper with a compact dish on the roof!

This change has resulted in a drastic reduction of cable-carrying capacity. After installing the required rack equipment and then adding two passengers, the payload margin of such vehicles can shrink to only a few hundred pounds — enough for perhaps 500’ of A/V and power cables plus minimal grip gear.

Of course, breaking news is not always conveniently located within 500 feet of available parking. In an intensely competitive business, no news organization wants to be stuck hundreds of feet away from the live action, while competitors move in right on top of it. And squeezing in additional cable reels can result in an overloaded vehicle, which can prove extremely dangerous when proceeding as quickly as (legally) possible to the breaking news site.

Consequently, to gain a competitive edge, many news organizations are equipping their new vans and SUVs with fiber optic capability. Because the fiber optic cables are dramatically smaller and lighter than copper multi-cable equivalents, a fiber-equipped news operation can report live “from where the action is” without sacrificing the lower operating costs and easier licensing requirements of smaller vehicles. In addition, these operations also have the benefit of full, uncompressed HD-SDI signal capability from camera to van.

## Field Operation, Maintenance and Troubleshooting

The integration of fiber optic transmission in to ENG/SNG operations will greatly extend the reach of live coverage, particularly if HD-SDI capability is implemented or planned. In most other respects, however, integration of fiber optic transmission should be seamless and transparent.

### Cable Deployment and Connection

Field deployment of fiber optic cables differs little from that of copper cables, with a few important exceptions.

First, reasonable care must be taken to insure that dust and dirt do not intrude into the fiber optic connections. In nearly all circumstances, this should not be a problem, as the types of connectors recommended for ENG/SNG are the expanded beam type or self-capping when not in use. However, when assignments are situated near events producing dense airborne particulates (fires, explosions), extra precautions should be observed whenever the connectors are exposed.

On the other hand, a far more common environmental condition — water — is of no concern with fiber optic systems. Fiber optic connectors may be exposed to heavy rain, and even be submerged in water, with no signal loss or degradation.

When deploying fiber optic cable, the field crew must also be aware that fiber optic cable does have a minimum bend radius. This is the degree, or “tightness,” that a cable can sustain before the light rays lose their ability to continue propagation in the core. In normal operation, this will not be a concern, as long as there is some slack in the cable: the inherent stiffness of the cable’s reinforcement fibers and outer jacket normally will keep the cable from bending too tightly when gently looped or tied in a loose knot. However, any knots should be avoided, as should the cable be snagged and

pulled tight, the minimum bend radius could be exceeded. By the same token, looping the cable around narrow, rigid objects should be avoided if there is a chance the cable will be inadvertently tensioned. Unless the cable is damaged — likely only if pulled across sharp objects or with extreme tension — the signal will be restored immediately when the bend is released and the radius again falls within tolerances.

#### *Side Note: Crush Resistance, Bend Radius and Tensioning*

Both tactical fiber optic cables and low-loss coaxial cables share some common characteristics when it comes to cable deployment precautions. To a greater or lesser extent — dependent on a number of factors — both are susceptible to signal degradation or loss if the cable is bent too tightly, or too many times within a short distance. Also, both are subject to signal interruption or damage if crushed, severely crimped, or subjected to extreme tension. However, the degree to which each type is subject to signal interruption or permanent damage varies considerably, primarily due to the dramatically different physical properties of the cables.

**Crush Resistance** — A coaxial cable has two conductors: a solid copper conductor in the center and an outer metallic shield. Separating the two at a constant distance is an insulating material called the dielectric. The nature of the dielectric material is critical in determining the amount of return loss (RL) exhibited by the cable. A higher RL will restrict the ability of the coaxial cable to carry high bandwidth signals over longer distances.

For a cable with the lowest possible RL losses, the ideal dielectric would be a total vacuum; the next best would be air. As both are impractical for field use, coaxial cables instead use an insulating material such as solid polyethylene or polyethylene foam. Since air is a much better dielectric than the solid plastic, a foam dielectric makes a good compromise. It reduces the amount of RL and allows construction



of cables that can carry high bandwidth signals such as HD-SDI a distance of several hundred feet.

Unfortunately, compared to cables with solid cores, these low-loss coaxial cables are less flexible and have much lower crush resistance. Tightly crimping the cable, dropping a heavy object on it, or running over it with a vehicle can permanently deform the foam dielectric. This changes the cable impedance and will permanently degrade the cable's distance/bandwidth performance.

A tactical fiber cable behaves differently, as the physical construction is markedly different. Everything inside the cable is a dense, solid material — glass fibers, aramid fibers, and plastic buffers. There is nothing that can be easily crushed or deformed. Consequently, it is possible to drive a vehicle over the cable, place heavy crates on it, and bend it under tension around sharp corners without permanently harming the cable. A severe impact on the cable may cause a momentary signal interruption due to a temporary polarization effect (called birefringence), but unless the internal fiber is severed, the cable will be restored to full performance within a fraction of a second.

**Bend radius** — Both low-loss coaxial and fiber optic cable can experience performance degradation or signal loss due to excessive bending. However, once again, different principles and standards are involved.

With coaxial cables, tight bends can temporarily deform the dielectric and change the relationship between the core conductor and the shield. This again increases the RL and degrades signal performance. A rule of thumb has been that coaxial cable should not be bent at less than 10x diameter, though many cables will perform well when bent at 3x-5x diameter. However, higher bandwidth signal bandwidth will lower the tolerance for excessive bending. A cable that functions well with a 3x bend for analog NTSC may indeed limit allowable bending to no more than 10x diameter to work reliably with HD-SDI.

With fiber optic cable, the situation is different. The bandwidth of the signal modulated onto the fiber is irrelevant. Instead, minimum bend radius is determined by the wavelength of the carrier light beam and the characteristics of the cable.

When using the 1300 nm wavelength (recommended for ENG/SNG), the 10x diameter is also a good rule of thumb for single-mode transmission. Newer, bend-insensitive tactical fibers now are coming on the market that may reduce this figure as well.

Regardless of cable type, the 1550 nm wavelength is less forgiving; however, the extreme long distance capabilities of this wavelength are normally less important than the added robustness of 1300 nm in ENG/SNG applications.

In typical field operations, a tactical fiber cable using 1300 nm will not experience interruption unless pulled tight at close to 180 degrees. At that point, light scatter from the core into the cladding can degrade or interrupt the signal. However, once the cable opens beyond the minimum radius, full signal performance is restored.

### FIBER OPTIC CABLE BEND RADIUS

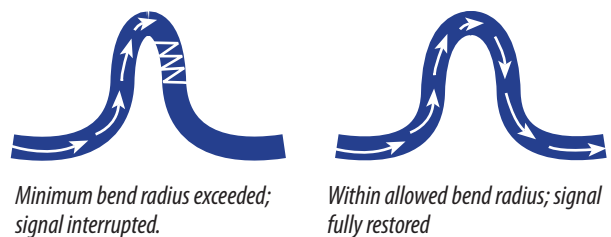

**Tensile strength** — When stretched to great extremes, both copper and fiber optic cables will separate, causing signal loss. However, copper does have some elasticity, whereas the glass cores of fiber optic cables are non-elastic. In typical field operations, the aramid strength fibers of tactical fiber cables will prevent breaks and maintain full signal integrity. Nevertheless, reasonable precautions should be taken to prevent fiber optic cables – and SMPTE hybrid cables



in particular – from being snagged by moving equipment or pulled taut over long distances.

**The Bottom Line** — The higher bandwidth requirements of HD-SDI production have shifted the balance between copper and fiber optic cables in field deployment applications. Even when cable deployments are within the range of coaxial cables (typically 100 –300 feet), the low-loss cable type required to carry HD-SDI will be inherently less flexible and more prone to permanent crush damage in comparison to tactical fiber. Though coaxial cables have a small technical advantage in minimum bend radius, with new-generation fiber optic cables operating at 1330 nm this difference is of little practical consequence in field operations.

### Optical Loss Budgeting

Optical loss budgeting is a simple mathematical calculation of the optical power loss — or “signal dimming” — caused by the light passing through connectors and long fiber optic cables. If a system’s optical loss budget is exceeded, the receiver may not be able to accurately demodulate the information carried by the light beam, resulting in signal degradation or loss.

Fortunately, optical loss budgeting is rarely a concern in ENG/SNG applications, as the maximum distances normally encountered are well within the capabilities of single-mode fiber systems — even when multiple intermediate connections are required.

To determine the optical loss budget of a fiber optic system, you first note the specified transmitter output power, referenced in dBm, with 0 dBm equal to 1 mW. A transmitter using a standard laser will typically have an output of -8 dBm to -6 dBm. An optional high-power laser may have an output of 0 dBm. The other critical figure in determining your optical loss budget is receiver sensitivity. This is the amount of power that is required to be present at the receiver input for operation according to full specification. Different sensitivity figures may apply to SD and HD signals, as

the higher bandwidth of HD requires greater signal definition. For example, the SD sensitivity may be specified as -30 dBm while HD sensitivity is given as -22 dBm.

The optical loss budget is the difference in dB between the transmitter output power and the receiver sensitivity. For example, for an HD signal in a system using a standard laser, the optical loss budget will be around 16 dB. (As the comparison is relative, using the same units, the “m” of dBm is dropped.)

The next step is to compute the total optical losses (attenuation) contributed by the cable and connectors. Single-mode fiber optic cable typically attenuates the signal less than 1 dB per km. A good field-terminated physical contact (PC) connector (as used at base station input) will have an insertion loss of 0.5 to 1.0 dB. Expanded beam connectors — the type preferred for field connect/disconnect — will have an insertion loss of 1.0 to 1.5 dB.

A typical fiber optic system for ENG/SNG will require one or two PC connectors and, at most, three or four more expanded beam connectors. This gives a total connector insertion loss of about 8 dB maximum. Theoretically, this would allow up to 8 km of fiber optic cable. However, it is always good idea to allow ample headroom in the fiber loss budget to allow for worst-case scenarios, such as small dust particles intruding into connectors. And even with extra headroom, the distance allowed usually far exceeds requirements of ENG/SNG operations.

### OPTICAL LOSS BUDGET: TYPICAL ENG/SNG

System optical loss limit: 15 dB

Component(s)	Loss per unit	Units	Subtotal
PC connectors	1.0 db	2	2.0 dB
MX connectors	1.5 db	3	4.5 dB
Single mode fiber	1.0 dB/km	1.5 km	1.5 dB
Minimum insertion loss total			8.0 dB
Optical “headroom” (15dB – 8.0dB)			7.0 dB

## Field Maintenance and Troubleshooting

**Cable inspection** — Regular inspection of the cable helps prevent any transmission degradation or loss due to cable malfunction. In particular, the cable should be examined to detect any evidence that the outer jacket and internal reinforcement fibers have been severed. A severely cut cable should be replaced, even if still functional, as inadvertent tensioning could damage the optical fibers.

**Cable testing** — Relatively inexpensive testing equipment allows quick field checks of fiber optic cables. The most basic check is to determine if the cable has optical continuity. Do NOT look into the cable when it is connected to the transmitter and might be in operation; this could result in eye damage. Small light sources with multiple connectors are available for “offline” checking of cable reels when disconnected from the transmitter. If a dedicated test light source is not available, a regular flashlight may be used instead.

If a light beam is present, the second step is to check the optical power. An optical power meter is calibrated to read each of the wavelength windows used in fiber optic transmission. The meter can be connected via a short jumper cable to the transmitter to confirm that the output power is at or near specification.

The meter can then be inserted at intermediate points to determine if the attenuation readings correspond to the calculated optical losses. As soon as a significant disparity is discovered, the likely source of trouble should be investigated. In most cases, an abnormally low signal will be caused by a misaligned, mismatched or dirty connector.

**Connector cleaning and repair** — The most important single requirement for field maintenance of fiber optic system is periodic and careful cleaning of connectors. Loose dust and dirt particles can be blown out using compressed air. Otherwise, any contact cleaning should use only lint-free optical wipes and 100% pure isopropyl alcohol. If mud gets into a field connector, it can be rinsed away carefully with clean water, taking extreme care not to “scrub” against the lenses of expanded beam connectors. The connector should be thoroughly dried before use, as small water droplets or residues could impair performance. If oil should get into a connector, it can be removed with most common cleaning solvents, again using the same precautions as with water cleaning.

Though possible in some circumstances, field repair of fiber optic connectors is generally difficult and not recommended. Repair techniques will vary considerably with connector type, and are therefore not covered here.

## Appendices

### Glossary

**Aramid** — An extremely strong synthetic fiber that woven into fiber optic cables to add tensile strength. A well-known trade name is Kevlar.

**Bandwidth** — In digital systems, bandwidth is the highest data rate a system can transmit without unacceptable losses. In digital TV applications, bandwidth is specified in Megabits per second (Mbps) or Gigabits per second (Gbps).

**Bend radius** — The smallest radius around which a coaxial or fiber optic cable can bend before excessive attenuation causes signal loss.

**Cladding** — A layer of glass or other transparent material with a lower refractive index than the core. The cladding confines light within the core and promotes propagation of light down an optical fiber.

**Coarse Wavelength Division Multiplexing (CWDM)** — A passive optical process by which multiple signals may be combined into one light beam for transmission over a fiber optic cable.

Coarse WDM (CDWM) – 4, 8 or 16 channels on one fiber

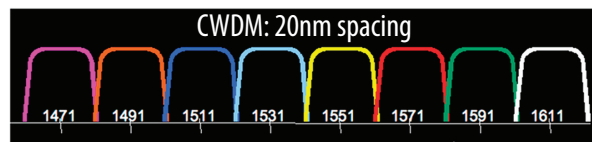

**Core** — The extremely thin glass fiber that serves as the light conducting part of a fiber optic strand. The core has a higher refraction index than the surrounding concentric cladding material.

**CWDM** — See Coarse Wavelength Division Multiplexing.

**DFB laser** — Distributed feedback laser, a high-output design that enables long distance transmission (up to 30 km) over single-mode fiber.

**Dielectric** — The insulating material used in coaxial cables to separate the core conductor from the shield and maintain the separation at a constant distance. Low-loss cables use a foam dielectric that is more susceptible to crushing than solid dielectrics.

**Expanded beam connector** — A design wherein the fiber core of each cable terminates in a small lens which expands the light beam so it can pass around any microscopic particles before capture by the opposing lens. Though expanded beam connectors are more robust than physical contact (PC) connectors, they do exhibit higher optical losses.

**HD-SDI (High Definition Serial Digital Interface)** — A standard for uncompressed transmission of digital HD video signals as defined by SMPTE 292M. HD-SDI requires minimum system bandwidth of 1.5 Gbps.

**Hermaphroditic connectors** — Connectors that can function as EITHER gender, allowing any cable with the same connector type to be connected at either end.

**Multimode fiber** — A fiber optic cable with a core strand of sufficient thickness for light rays to reflect off the cladding at multiple angles, allowing multiple paths (modes) of transmission through the fiber strand. Multiple modes cause modal dispersion, which limits bandwidth and effective transmission distance.

**Multiplexing** — A process by which two or more signals are combined into one signal. Electrical systems use Time Division Multiplexing (TDM) and Frequency Division Multiplexing (FDM). Optical systems for broadcast applications use Wave Division Multiplexing (WDM) and Coarse Wave Division Multiplexing (CWDM); many broadcast systems use electrical multiplexing prior to optical multiplexing.

**Optical loss budget** — The amount of optical loss (“light dimming”) from cable length and connectors that a fiber optic system can tolerate before it fails to meet operating specifications.

**Receiver** — The component in a fiber optic system that receives the light signal and converts it into an electrical signal. Many receiver units also incorporate signal de-multiplexing functions.

**Single-mode fiber** — A fiber optic cable with an extremely small core that allows light rays to only pass longitudinally, without reflecting off the cladding at multiple angles. Single mode fiber is not subject to modal dispersion, and therefore can transmit higher bandwidth signals over longer distances than multimode fiber.

**SMPTE hybrid cable** — A special type of cable, defined by SMPTE standard 311, which comprises two single-mode optical fibers and four copper electrical conductors. The cable carries video signals (HD-SDI capable) between a

camera and the associated camera control unit (CCU), and also supplies power to the camera.

**Transceiver** — A single hardware unit that incorporates the function of both a transmitter and a receiver.

**Transmitter** — A device that contains a light source, usually a laser, as well as electronic circuits for converting electrical signal to optical signals. Many transmitter units also incorporate signal multiplexing functions.

**Wavelength Division Multiplexing** — A technique by which multiple signals are propagated through a single fiber by transmitting them at different wavelengths.

**WDM** — Send 2 simultaneous channels on one fiber



**WDM** — See Wavelength Division Multiplexing.

## Distance and Bandwidth Comparison Chart

The following chart shows the distances for five methods of signal transmission: two coaxial cable, and three fiber optic. For purposes of simplicity, only one signal per cable is assumed; however, the fiber cables are capable of carrying multiples of each signal or other auxiliary signals, either multiplexed on one fiber or in a multi-core fiber cable.

Signal type	Composite NTSC	Component SDI	HD-SDI	1080p/50 1080p/60
Data rate	143 Mb/s	270 Mb/s	1.5 Gb/s	3.0 Gb/s
SMPTE standard	259M	259M	292M	424M
Coax 1	381 m	262 m	N/A	N/A
Coax 2	573 m	326 m	87 m	58 m
SM Fiber 1300 nm	5,000 m	5,000 m	5,000 m	5,000 m
SM Fiber 1550 nm DFB	30,000 m	30,000 m	30,000 m	30,000 m







Telecast-Fiber Systems, Inc.  
102 Grove Street , Worcester, MA 01605  
P: 508-754-4858 F: 508-752-1520  
[www.telecast-fiber.com](http://www.telecast-fiber.com)