

CO-OWNER INFORMATION BOOK

HIDDEN HARBOR CONDOMINIUM

**A RESIDENTIAL CONDOMINIUM
LOCATED IN THE TOWNSHIP OF WATERFORD
OAKLAND COUNTY, MICHIGAN**

UPDATED: January, 2023

**HIDDEN HARBOR CONDOMINIUM
TABLE OF CONTENTS**

**AMENDED AND RESTATED MASTER DEED
HIDDEN HARBOR CONDOMINIUM**

**AMENDED AND RESTATED CONDOMINIUM BYLAWS
HIDDEN HARBOR CONDOMINIUM**

**CONDOMINIUM SUBDIVISION PLAN
HIDDEN HARBOR CONDOMINIUM**

**ARTICLES OF INCORPORATION
HIDDEN HARBOR CONDOMINIUM ASSOCIATION**

**CERTIFICATE OF AMENDMENT TO THE
ARTICLES OF INCORPORATION
HIDDEN HARBOR CONDOMINIUM ASSOCIATION**

**AMENDED AND RESTATED
MASTER DEED
HIDDEN HARBOR CONDOMINIUM**

**AMENDED AND RESTATED MASTER DEED OF
HIDDEN HARBOR CONDOMINIUM**

TABLE OF CONTENTS

ARTICLE I	TITLE AND NATURE.....	2
Section 1.	Condominium Name and Subdivision Plan Number	2
Section 2.	Units and Co-owner Rights of Access to Common Elements	2
ARTICLE II	LEGAL DESCRIPTION.....	2
ARTICLE III	DEFINITIONS.....	2
Section 1.	General Description of Terms Used	2
Section 2.	Number and Gender of Words	4
ARTICLE IV	COMMON ELEMENTS.....	4
Section 1.	Common Elements.....	4
Section 2.	Responsibility for Unit and Common Elements.....	6
ARTICLE V	USE OF UNITS AND COMMON ELEMENTS	9
ARTICLE VI	UNIT DESCRIPTION AND PERCENTAGE OF VALUE.....	9
Section 1.	Unit Description	9
Section 2.	Calculation of Percentage of Value	9
ARTICLE VII	EASEMENTS.....	10
Section 1.	Easements for Encroachment, Utilities and Support	10
Section 2.	Association's Right to Grant Easements.....	10
Section 3.	Association's and Utility Companies' Easements for Maintenance, Repair and Replacement	10
ARTICLE VIII	AMENDMENTS	11
Section 1.	Association Amendments	11
Section 2.	Co-owner Approval	11
Section 3.	Mortgagee Consent	11
Section 4.	Modification of Units, Limited Common Elements and Percentage of Value	11
Section 5.	Amendments for Secondary Mortgage Market Purposes.....	12

RECEIVED
OAKLAND COUNTY
REGISTER OF DEEDS

2023 JAN 12 AM 11:06

005383 Liber 58373 Page 399 UCC #
1/13/2023 9:26:09 AM Receipt #000004291
\$21.00 Misc Recording
\$4.00 Remonumentation
\$5.00 Automation
\$0.0 Transfer Tax
PAID RECORDED - Oakland County, MI
Lisa Brown, Clerk/Register of Deeds

**AMENDED AND RESTATED MASTER DEED OF
HIDDEN HARBOR CONDOMINIUM
(ACT 59, PUBLIC ACTS OF 1978, AS AMENDED)
OAKLAND COUNTY CONDOMINIUM SUBDIVISION PLAN NO. 491**

This Amended and Restated Master Deed of Hidden Harbor Condominium (“Amended and Restated Master Deed”) is made and executed this 6th day of January, 2023, by Hidden Harbor Condominium Association, a Michigan nonprofit corporation (the “Association”), in accordance with the Michigan Condominium Act (being Act 59 of the Public Acts of 1978, as amended) (the “Condominium Act”).

The Association desires by recording this Amended and Restated Master Deed to reaffirm the establishment of the real property described in Article II of this Amended and Restated Master Deed, together with all the improvements now located upon or appurtenant to the real property, as a residential condominium project under the Condominium Act. The Master Deed for Hidden Harbor Condominium, recorded in Liber 9852, Page 771 et seq., the First Amendment recorded in Liber 10244, Page 782 et seq., the Second Amendment recorded in Liber 17192, Page 292 et seq., and the Third Amendment recorded in Liber 52068, Page 811 et seq., Oakland County Records, are superseded by this Amended and Restated Master Deed (except for the Condominium Subdivision Plan (defined in Article II below) attached to the original Master Deed as Exhibit B).

The Association, upon the recording of this Amended and Restated Master Deed, reaffirms the establishment of Hidden Harbor Condominium as a condominium under the Condominium Act and declares that Hidden Harbor Condominium shall be held, conveyed, hypothecated, encumbered, leased, rented, occupied, improved, or in any other manner utilized, subject to the Condominium Act, and to the covenants, conditions, restrictions, uses, limitations, and affirmative obligations set forth in this Amended and Restated Master Deed and Exhibits A and B applicable to this Amended and Restated Master Deed, all of which run with the real property described in Article II of this Amended and Restated Master Deed and are a burden and a benefit to the Association, its successors and assigns, and any persons acquiring or owning an interest in such real property, their grantees, successors, heirs, executors, administrators and assigns. In furtherance of the Condominium’s establishment, it is provided as follows:

499
ENV

13-04-429-000ENV

UK - AB

**ARTICLE I
TITLE AND NATURE**

Section 1. Condominium Name and Subdivision Plan Number. The Condominium is known as Hidden Harbor Condominium, Oakland County Condominium Subdivision Plan No. 491. The Condominium is established in accordance with the Condominium Act.

Section 2. Units and Co-owner Rights of Access to Common Elements. The Units, including the number, boundaries and dimensions of each Unit, are set forth in the Condominium Subdivision Plan. Each Unit is capable of individual utilization because it has access to a Common Element. Each Co-owner has an exclusive right to their Unit and has an undivided and inseparable right to share with the other Co-owners the Common Elements designated by this Amended and Restated Master Deed.

**ARTICLE II
LEGAL DESCRIPTION**

The land that comprises the Condominium covered by this Amended and Restated Master Deed, which is located in the Township of Waterford, Oakland County, Michigan, is particularly described as follows:

PART OF THE SOUTHWEST ¼ OF SECTION 3 AND PART OF THE SOUTHEAST ¼ OF SECTION 4, T.3N., R.9.E, WATERFORD TOWNSHIP, OAKLAND COUNTY, MICHIGAN, DESCRIBED AS COMMENCING AT THE MOST EASTERLY CORNER OF EAGLE LAKE HEIGHTS SUBDIVISION (L. 49, P. 44, O.C.R.) THENCE NORTH 48 DEGREES 10 M INUTES 20 SECONDS WEST ALONG THE NORTHEASTERLY LINE OF SAID SUBDIVISION 148.50 FEET TO THE POINT OF BEGINNING, THENCE NORTH 48 DEGREES 10 MINUTES 20 SECONDS WEST ALONG SAID SUBDIVISION LINE 394.30 FEET TO THE EAST-WEST ¼ LINE OF SAID SECTIONS 3 & 4, THENCE SOUTH 88 DEGREES 14 MINUTES 00 SECONDS EAST ALONG THE ¼ LINE 825.79 FEET, THENCE SOUTH 02 DEGREES 28 MINUTES 27 SECONDS WEST 199.12 FEET, THENCE SOUTH 66 DEGREES 50 MINUTES 38 SECONDS WEST 238.82 FEET, THENCE NORTH 89 DEGREES 01 MINUTES 40 SECONDS WEST 193.15 FEET, THENCE NORTH 61 DEGREES 25 MINUTES 00 SECONDS WEST 75.90 FEET, THENCE NORTH 70 DEGREES 11 MINUTES 00 SECONDS WEST 46.40 FEET TO THE POINT OF BEGINNING. CONTAINING 4.167 ACRES MORE OR LESS. SUBJECT TO EASEMENTS OF RECORD.

**ARTICLE III
DEFINITIONS**

Section 1. General Description of Terms Used. Certain terms are utilized not only in this Amended and Restated Master Deed and Exhibits A and B but are or may be used in various other instruments such as, by way of example and not limitation, the Articles of Incorporation

and rules and regulations of Hidden Harbor Condominium Association, and deeds, mortgages, liens, land contracts, easements and other instruments affecting the establishment or transfer of interests in Hidden Harbor Condominium. Wherever used in these documents or any other pertinent instruments, the terms set forth below are defined as follows:

A. The “Act” or “Condominium Act” means the Michigan Condominium Act, being Act 59 of the Public Acts of 1978, as amended. If any provision of this Amended and Restated Master Deed or its exhibits conflicts with any provision of the Condominium Act, or if any provision required by the Condominium Act is omitted, then the Condominium Act provisions are incorporated by reference and shall supersede and cancel any conflicting provision.

B. “Amended and Restated Bylaws” or “Bylaws” means Exhibit A attached to this Amended and Restated Master Deed, being the Bylaws setting forth the substantive rights and obligations of the Co-owners. The Amended and Restated Bylaws also constitute the Association's corporate bylaws under the Michigan Nonprofit Corporation Act.

C. “Amended and Restated Master Deed” means this document, and to which the Amended and Restated Bylaws are attached as Exhibit A, and the Condominium Subdivision Plan is made applicable as Exhibit B.

D. “Association” means Hidden Harbor Condominium Association, a nonprofit corporation organized under Michigan law of which all Co-owners are members. The Association shall administer, operate, manage and maintain the Condominium in accordance with all applicable laws and the Condominium Documents (defined below). Any action required of or permitted to the Association is exercisable by its Board of Directors unless specifically reserved to the Co-owners by the Condominium Documents or Michigan law.

E. “Common Elements” where used without modification means both the General and Limited Common Elements described in Article IV of this Amended and Restated Master Deed and does not refer to Units.

F. “Condominium” means Hidden Harbor Condominium as a Condominium established in conformity with the Condominium Act, and includes without limitation the land, buildings, structures and other improvements located on the property described in Article II of this Amended and Restated Master Deed and all easements, rights and appurtenances belonging to the Condominium.

G. “Condominium Documents” means and includes this Amended and Restated Master Deed, the Amended and Restated Bylaws, the Condominium Subdivision Plan, the Association's Articles of Incorporation, and the Association’s rules and regulations.

H. “Condominium Subdivision Plan” means the Condominium Subdivision Plan attached to the original Master Deed as Exhibit B, which is incorporated and made applicable by reference.

I. "Co-owner" means an individual, firm, corporation, limited liability company, partnership, association, trust or other legal entity or any combination of the foregoing who or which owns one or more Units. Both land contract vendees and vendors are considered Co-owners and are jointly and severally liable for all obligations and responsibilities of Co-owners under the Condominium Documents and the Condominium Act.

J. "Developer" refers to Eagle Venture Development Corporation, a Michigan corporation, which made and executed the original Master Deed.

K. "Electronic transmission" means transmission by any method authorized by the person receiving the transmission and not directly involving the physical transmission of paper, which creates a record that may be retrieved and retained and that may directly reproduce in paper through an automated process.

L. "Good standing" means a Co-owner who is current in all financial obligations owing to the Association and is not in default of any of the Condominium Document provisions.

M. "Person" means an individual, firm, corporation, limited liability company, partnership, association, trust, or other legal entity, or any combination of the foregoing.

N. "Unit" means a single Unit in Hidden Harbor Condominium, as described in Article VI of this Amended and Restated Master Deed and on the Condominium Subdivision Plan and shall have the same meaning as the term "Condominium Unit" as defined in the Condominium Act.

Section 2. Number and Gender of Words. Whenever any reference is made to one gender, the same shall include a reference to all genders where the same would be appropriate. Similarly, whenever a reference is made to the singular, a reference shall also be included to the plural where the same would be appropriate.

ARTICLE IV COMMON ELEMENTS

Section 1. Common Elements. The Common Elements are described in the Condominium Subdivision Plan and as follows:

A. General Common Elements. The General Common Elements are:

(1) Land. The land described in Article II of this Amended and Restated Master Deed, including paved and landscaped areas, all to the extent not designated as Limited Common Elements;

(2) Electrical. The electrical transmission system throughout the Condominium, including that contained within Unit walls, up to the point of connection with electrical outlets or fixtures within any Unit;

(3) Gas. The gas distribution system throughout the Condominium, including that contained within Unit walls, up to the point of connection with gas fixtures within any Unit;

(4) Telephone. The telephone system throughout the Condominium up to the point of connection with outlets within any Unit;

(5) Plumbing. The plumbing network throughout the Condominium, including that contained within Unit walls, up to the point of connection with plumbing fixtures within any Unit;

(6) Cable Television. The cable television system throughout the Condominium up to, but not including, connections to provide service to individual Units;

(7) Sanitary Sewer. The sanitary sewer system throughout the Condominium, including that contained within Unit walls, up to the point of connection with plumbing fixtures within any Unit;

(8) Storm Sewer. The storm sewer system throughout the Condominium;

(9) Construction. Foundations, supporting columns, Unit perimeter walls (including windows, doors and door-walls within the Unit perimeter walls), roofs, ceilings, floor construction between Unit levels, attics, developer-installed insulation, and chimneys;

(10) Maintenance Sheds. The maintenance sheds;

(11) Irrigation System. The irrigation system throughout the Condominium, including all lines, valves, timers, heads and related equipment;

(12) Entryway Signage and Improvements. The entryway signage and related improvements and landscaping; and

(13) Other. All other elements and improvements contained within or appurtenant to the Condominium, which are not designated as General or Limited Common Elements, which are not enclosed within the boundaries of a Unit and which are intended for common use or are necessary to the existence, upkeep and safety of the Condominium.

Some or all of the utility lines, systems (including mains and service leads) and equipment described above (“utility systems”) may be owned by the local public authority or by the company that is providing the pertinent service. Accordingly, the utility systems are General Common Elements only to the extent of the Co-owners' interest in the utility systems, if any.

Some or all of the utility systems service single buildings containing more than one Unit. Accordingly, and where necessary or applicable, there are easements for that Common Element through each Unit to enable the utility systems to appropriately serve each of the Units in the subject building.

B. Limited Common Elements. Limited Common Elements are subject to the exclusive use and enjoyment of the Co-owner of the Unit to which the Limited Common Elements serve. The Limited Common Elements follow:

(1) Stairs. The stairs are limited in use to the Co-owners of Units that gain access over the stairs as shown on the Condominium Subdivision Plan;

(2) Carports. Each carport is limited in use to the Co-owner of the Unit to which the carport is assigned as shown on the Condominium Subdivision Plan;

(3) Balconies. Each balcony is limited in use to the Co-owner of the Unit to which the balcony is appurtenant as shown on the Condominium Subdivision Plan;

(4) Heating and Air Conditioning. Each heating and air conditioning unit is limited in use to the Co-owners of the Units to which the heating or air conditioning unit is appurtenant as shown on the Condominium Subdivision Plan;

(5) Interior Surfaces. The interior surfaces of ceilings, floors and perimeter walls (including windows, doors and door-walls within the Unit perimeter walls) contained within a Unit are limited in use to the Co-owner of the Unit to which the interior surfaces are appurtenant; and

(6) Hot Water Heaters. The hot water heaters located in building 1 is limited in use to the Co-owners of the Units within building 1. The hot water heaters located in building 2 are limited in use to the Co-owner of the Unit to which the hot water heater is appurtenant.

Section 2. Responsibility for Unit and Common Elements. Subject to the Association's exclusive right and obligation to control and approve the exterior appearance and use of all Units and Common Elements as set out in this Amended and Restated Master Deed and in the Amended and Restated Bylaws, the respective responsibilities for the maintenance, decoration, repair and replacement of the Units and Common Elements are as follows:

A. Co-owner Responsibilities:

(1) Unit and Certain Common Elements. Except as provided in Section 2B below and subject to the Amended and Restated Bylaws, each Co-owner is responsible for maintenance, decoration, repair and replacement, including all associated costs, of a Unit, including all fixtures, improvements and personal property located within the Unit or elsewhere throughout the Condominium, the Limited Common Elements, and those General Common Elements described in this Section 2A(1). The following provisions add to and clarify, but do not limit, each Co-owner's decoration, maintenance, repair and replacement responsibilities under this Section 2A(1):

(a) Electrical. Electrical fixtures, outlets, switches, circuit breakers, breaker box and panels located within and serving the individual Unit;

- (b) Gas. Gas fixtures located within and serving the individual Unit;
- (c) Water. Plumbing fixtures located within and serving the Unit including rings, seals, washers, supply lines and shutoff valves located within the Unit and serving an individual plumbing fixture;
- (d) Drain Lines. Drain lines and traps located within the Unit and that serve only individual plumbing fixtures located within the Unit;
- (e) Telecommunications Systems. Cable, telephone and telecommunication systems from and including the junction or demarcation box;
- (f) Heating and Air-conditioning. Each heating and air-conditioning unit and related equipment and accessories;
- (g) Hot Water Heaters. The Co-owners of Units in building 1 are responsible for the hot water heaters located in building 1. The utility charges for the hot water heaters in building 1 shall be estimated and determined by the Board of Directors and paid through monthly assessments of the Co-owners in building 1. The Co-owners of Units in building 2 are responsible for hot water heater appurtenant to their Unit, including all utility charges;
- (h) Windows, Door-walls, Unit Entry Doors and Interior Doors. Windows, door-walls, Unit entry doors and interior doors, including, screens, frames, locks, hardware, storms and weather stripping; provided, the Association is responsible for the periodic exterior painting of the exterior of Unit entry doors in accordance with the Association's maintenance schedule;
- (i) Unit Interior Wall Construction. Unit interior wall construction;
- (j) Balcony. Balcony and all improvements located on or related to the balcony;
- (k) Appliances and other Equipment. Appliances and equipment within the Unit and supporting hardware and equipment including, but not limited to personal alarm systems, smoke and carbon monoxide detectors, garbage disposal, dishwasher, microwave, range, oven, refrigerator, vent fans, dryer venting within the Unit, and vent covers and filters;
- (l) Improvements and Decorations. Improvements and decorations to the Unit including, without limitation, tile, either floor or wall, paint, wallpaper, window treatments, carpeting or other floor covering, trim, cabinets, counters, sinks and related hardware;
- (m) Other. All other items not specifically enumerated above, but which are located within the boundaries of a Unit.

(2) Co-owner Additions, Modifications. Co-owner improvements, additions or modifications, even though approved by the Board of Directors, are not considered Common Elements in any case and, except as the Board determines otherwise in writing, are the complete responsibility of the Co-owner. Should the Association require access to any Common Elements which necessitates the moving or destruction of all or part of any addition or modification, all costs, damages and expenses involved in providing access and restoring the addition or modification shall be assessed to and collected from the responsible Co-owner in the manner provided in Article II of the Amended and Restated Bylaws. Co-owners shall not alter, replace, remove, paint, decorate or change the exterior of a Unit or any exterior appendage including, without limitation, any balcony, air conditioning units, windows and Unit entry doors, whether exclusively used by the Co-owner or otherwise, without first obtaining the Board's prior written consent pursuant to Article VI of the Amended and Restated Bylaws. All maintenance, repair and replacement shall be performed in compliance with all applicable municipal, State and federal codes and regulations.

(3) Irrigation Equipment. A Co-owner whose Unit contains common irrigation equipment shall not restrict the Association or its contractors or utility companies from entering into the Unit to maintain, repair or replace the equipment. To ensure there is reasonable accessibility to the equipment, Co-owners shall not convert the portion of the Unit containing the equipment to living area without prior written approval of the Board of Directors. The Association shall not be responsible for damage to floor tile, carpeting, paneling, wall coverings, walls or other improvements or property in the Unit or Limited Common Elements if these items are blocking access to the equipment.

(4) Co-owner Fault. Subject to Article VI, Section 14 of the Amended and Restated Bylaws, all costs for maintenance, decoration, repair and replacement of any Common Element caused by the act of any Co-owner, or family, guests, tenants or invitees of a Co-owner, shall be borne by the Co-owner. The Association may incur these costs and charge and collect them from the responsible Co-owner in the same manner as an assessment in accordance with Article II of the Amended and Restated Bylaws.

B. Association Responsibilities:

(1) Limited Common Elements. Except in cases of Co-owner fault, the Association is responsible for the maintenance, repair and replacement of the stairs described in Section 1B(1) and the carports described in Section 1B(2) above, and the Association shall pay the expenses as an expense of administration;

(2) General Common Elements. Subject to this Article and the Amended and Restated Bylaws, and except as otherwise assigned to the Co-owners in subsection 2A above, the Association shall maintain, repair, and replace all General Common Elements and the Association shall pay the expenses as an expense of administration.

(3) Unauthorized Repair. The Association shall not be obligated to reimburse any Co-owner for repairs made or contracted for by the Co-owner. Unless otherwise determined

by the Board of Directors, the Association shall only be responsible for payments to contractors for work authorized by the Board of Directors.

C. Utility Charges. Each Co-owner is responsible for paying all individually metered or sub-metered utility services that serve their Unit. The Association is responsible for paying all commonly metered utilities as an expense of administration.

D. Unusual Expenses. Any other unusual common expenses benefiting less than all Units, or any expenses incurred because of the conduct of less than all of those entitled to occupy the Condominium, or by their licensees or invitees, shall be specifically assessed against the Unit or Units involved in accordance with Section 69 of the Condominium Act.

ARTICLE V USE OF UNITS AND COMMON ELEMENTS

No Co-owner shall use their Unit or the Common Elements in any manner inconsistent with the purposes of the Condominium, the Condominium Documents, zoning and other ordinances and codes of the Township of Waterford, State and Federal laws and regulations, or in any manner which will interfere with or impair the rights of any other Co-owner in the use and enjoyment of their Unit or the Common Elements.

ARTICLE VI UNIT DESCRIPTION AND PERCENTAGE OF VALUE

Section 1. Unit Description. The Condominium consists of 24 Units, numbered 1 through 24. Each Unit is described in this Section with reference to the Condominium Subdivision Plan. Each Unit includes all that space contained within the interior finished unpainted walls and ceilings and from the finished subfloor, all as shown on the floor plans and sections in the Condominium Subdivision Plan and delineated with heavy outlines. Building elevations are shown in detail in architectural plans and specifications on file with the Township of Waterford.

Section 2. Calculation of Percentage of Value. The percentage of value assigned to each Unit is determinative of the proportionate share of each Co-owner in the common proceeds and common expenses of administration (subject to the assignment of costs and expenses as reflected in Article IV of this Amended and Restated Master Deed), the value of each Co-owner's vote at Association meetings, and the undivided interests of each Co-owner in the Common Elements. The total percentage value of the Condominium is one hundred percent (100%). The percentages of value are equal.

ARTICLE VII EASEMENTS

Section 1. Easements for Encroachment, Utilities and Support.

A. If any Unit or Common Element encroaches upon another Unit or Common Element, whether by deviation from the plans in the construction, repair, renovation, restoration, or replacement of any improvement, or by reason of the settling or shifting of any land or improvement, an easement for the encroachment shall exist, except to the extent limited by Section 40 of the Condominium Act.

B. There are easements to, through and over those portions of the land, structures, buildings, improvements and walls contained therein for the installation, maintenance and servicing of all utilities in the Condominium, including, but not limited to, lighting, heating, power, sewer, water and communications including telephone, cable television and internet lines.

C. Easements of support shall exist with respect to any Unit wall that supports a Common Element.

Section 2. Association's Right to Grant Easements. The Board of Directors may grant easements and licenses over or through any portion of any General Common Elements for utility, roadway, construction, safety purposes, or for any other purpose as may be beneficial to the Condominium.

Section 3. Association's and Utility Companies' Easements for Maintenance, Repair and Replacement. The Association and all public or private utilities shall have easements over, under, across and through the Condominium, including all Units and Common Elements, as may be necessary to fulfill any responsibilities of maintenance, repair, decoration, replacement or upkeep which they or any of them are required or permitted to perform under the Condominium Documents or by law, or to respond to any emergency or common need of the Condominium. It is a matter of concern that a Co-owner may fail to properly maintain their Unit or any Common Elements for which the Co-owner is responsible in a proper manner and in accordance with the standards set forth in the Condominium Documents. Therefore, if a Co-owner fails to properly and adequately maintain, decorate, repair, replace or otherwise keep in good condition and repair their Unit or any improvements or appurtenances located within the Unit or any Common Elements for which the Co-owner is responsible, the Association shall have the right (but not the obligation) and all necessary easements to take whatever actions it deems desirable to so maintain, decorate, repair or replace the Unit, its appurtenances or any of the Common Elements for which the Co-owner is responsible, all at the expense of the Co-owner of the Unit. The Association shall not be liable to any Co-owner or any other person in trespass or in any other form of action for the exercise of rights pursuant to this Section or any other provision of the Condominium Documents that grant easements, rights of entry or other means of access. Failure of the Association to take any action shall not be deemed a waiver of the Association's right to take any action at a future time. All costs incurred by the Association in performing any Co-owner-responsibilities as set forth in this Section shall be assessed against the Co-owner in

accordance with Article II of the Amended and Restated Bylaws and shall be immediately due and payable. Further, the lien for nonpayment shall attach as in all cases of regular assessments, and the assessments may be enforced using all means available to the Association under the Condominium Documents and by law for the collection of regular assessments including, without limitation, legal action, foreclosure of the lien securing payment and imposition of fines.

Section 4. Driveway Easement. The Condominium is subject to and benefits from an easement providing ingress and egress which is recorded in Liber 9770, Page 121 Oakland County Records.

**ARTICLE VIII
AMENDMENTS**

This Amended and Restated Master Deed, the Amended and Restated Bylaws and the Condominium Subdivision Plan may be amended as provided in the Condominium Act and in the following manner, and shall be effective upon recordation with the Oakland County Register of Deeds:

Section 1. Association Amendments. The Association acting through its Board of Directors may make and record with the County amendments to this Amended and Restated Master Deed, the Amended and Restated Bylaws or the Condominium Subdivision Plan without the consent of Co-owners or mortgagees if the amendment does not materially alter or change the rights of a Co-owner or mortgagee.

Section 2. Co-owner Approval. Except as otherwise provided in this Amended and Restated Master Deed and subject to Sections 3 and 4 below, the Association may make and record with the County amendments to this Amended and Restated Master Deed, the Amended and Restated Bylaws or the Condominium Subdivision Plan upon the affirmative vote of two-thirds (2/3rds) of the Co-owners in good standing as of the voting date, which shall be the date that the acceptance of votes ends unless otherwise established by the Board of Directors.

Section 3. Mortgagee Consent. Whenever a proposed amendment would materially alter or change the rights of mortgagees (as defined in Section 90a(9) of the Condominium Act), the amendment shall require the consent of not less than two-thirds (2/3rds) of all first mortgagees of record in accordance with Section 90 of the Condominium Act. A mortgagee shall have one vote for each first mortgage held. Mortgagee approval shall be solicited in accordance with Section 90a of the Condominium Act.

Section 4. Modification of Units, Limited Common Elements and Percentage of Value. Notwithstanding any other provision of this Article, the method or formula used to determine the percentages of value of Units, as described in Article VI of this Amended and Restated Master Deed, may not be modified without the consent of each affected Co-owner and mortgagee, except as permitted by the Condominium Act, as amended. A Co-owner's Unit dimensions or appurtenant Limited Common Elements may not be modified without the Co-owner's consent. The Condominium may be terminated only in accordance with Section 51 of the Condominium Act. Common Elements can be assigned and reassigned only in accordance

with Section 39 of the Condominium Act. Units may be consolidated and boundaries relocated as provided in Sections 47 and 48 of the Condominium Act.

Section 5. Amendments for Secondary Mortgage Market Purposes. The Association may amend this Amended and Restated Master Deed or the Amended and Restated Bylaws to facilitate mortgage loan financing for existing or prospective Co-owners and to enable the purchase or insurance of such mortgage loans by the Federal Home Loan Mortgage Corporation, the Federal National Mortgage Association, the Government National Mortgage Association, the Veterans Administration, the Department of Housing and Urban Development, Michigan State Housing Development Authority or by any other institutional participant in the secondary mortgage market which purchases or insures mortgages. The foregoing amendments may be made without the consent of Co-owners or mortgagees.

[SIGNATURE AND ACKNOWLEDGMENT ON FOLLOWING PAGE]

The Association has caused this Amended and Restated Master Deed to be executed the day and year first above written

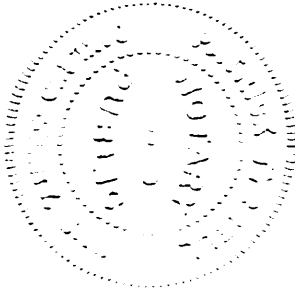

Hidden Harbor Condominium Association, a Michigan Nonprofit Corporation

By: Kelly M. Shier
Name: Kelly M. Shier
Title: Vice President

STATE OF MICHIGAN)
) SS:
COUNTY OF OAKLAND)

The foregoing instrument was acknowledged before me this 6th day of January, 2023 by Kelly M. Shier, the Vice President of Hidden Harbor Condominium Association, a Michigan Nonprofit Corporation, on behalf of the Corporation.

Patrick Tyrrell
_____, Notary Public
Oakland County, Michigan
Acting in Oakland County, Michigan
My Commission Expires: June 19th, 2026

Document drafted by and when recorded return to:
Evan M. Alexander, Esq.
Makower Abbate Guerra Wegner Vollmer PLLC
30140 Orchard Lake Rd.
Farmington Hills, MI 48334

PATRICK TYRRELL
NOTARY PUBLIC, STATE OF MI
COUNTY OF OAKLAND
MY COMMISSION EXPIRES Jun 19, 2026
ACTING IN COUNTY OF

Certifications attached to Amended and Restated Master Deed, follow

CERTIFICATION

STATE OF MICHIGAN)
) SS
COUNTY OF OAKLAND)

I, Robert Bakula, being first duly sworn, depose and state as follows:

1. I am the managing agent for Hidden Harbor Condominium Association, the corporation named in and which executed the Amended and Restated Master Deed and Amended and Restated Condominium Bylaws of Hidden Harbor Condominium.
2. The Amended and Restated Master Deed and Amended and Restated Condominium Bylaws of Hidden Harbor Condominium were submitted to all Co-owners of Units in Hidden Harbor Condominium for the purpose of voting on such documents. The Co-owners approved the documents by a vote of more than two-thirds of all Co-owners entitled to vote.



 Robert Bakula

Acknowledged, subscribed and sworn to before me
this 6 day of January, 2023.

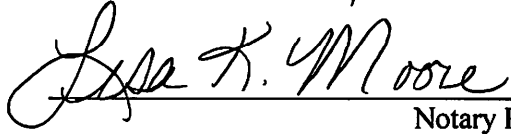

 Notary Public
County, Michigan

Acting in OAKLAND County
My Commission Expires: 8-28-2029

LISA K. MOORE
NOTARY PUBLIC, STATE OF MI
COUNTY OF OAKLAND
MY COMMISSION EXPIRES Aug 28, 2029
ACTING IN COUNTY OF OAKLAND

CERTIFICATION

STATE OF MICHIGAN)
) SS
COUNTY OF OAKLAND)

I, Evan M. Alexander, being first duly sworn, depose and state as follows:

1. I am the attorney for Hidden Harbor Condominium Association, the Corporation named in and which executed the attached Amended and Restated Master Deed and Amended and Restated Condominium Bylaws of Hidden Harbor Condominium.
2. I sent a copy of the attached Amended and Restated Master Deed and Amended and Restated Condominium Bylaws of Hidden Harbor Condominium and the ballot and notice required under Section 90A of the Michigan Condominium Act to all mortgagees of record of those Units qualified to vote, as listed in the records of the Oakland County Register of Deeds for the purpose of obtaining approval of said mortgagees to the Amended and Restated Master Deed and Amended and Restated Condominium Bylaws of Hidden Harbor Condominium.
3. Two-thirds (2/3^{rds}) of said mortgagees have consented to the attached Amended and Restated Master Deed and Amended and Restated Condominium Bylaws of Hidden Harbor Condominium in accordance with the provisions of Section 90A of the Michigan Condominium Act. Said consents will be maintained for a period of two years in Hidden Harbor Condominium Association records located in my office at 30140 Orchard Lake Rd., Farmington Hills, MI 48334.

Evan M. Alexander

Acknowledged, subscribed and sworn to before me this 11 day of January, 2023.

Daria Bilokopyta
Notary Public
Oakland County, Michigan
Acting in Oakland County
My Commission Expires: October 25, 2027

DARIA BILOKOPYTA
NOTARY PUBLIC, STATE OF MI
COUNTY OF OAKLAND
MY COMMISSION EXPIRES Oct 25, 2027
ACTING IN COUNTY OF Oakland

**AMENDED AND RESTATED
CONDOMINIUM BYLAWS
HIDDEN HARBOR CONDOMINIUM**

**AMENDED AND RESTATED BYLAWS
HIDDEN HARBOR CONDOMINIUM**

TABLE OF CONTENTS

ARTICLE I	ASSOCIATION OF CO-OWNERS.....	1
Section 1.	The Association	1
Section 2.	Purpose of Bylaws	1
ARTICLE II	ASSESSMENTS.....	1
Section 1.	Taxes and Assessments	1
Section 2.	Expenses and Receipts of Administration	1
Section 3.	Determination of Assessment.....	2
Section 4.	Payment of Assessments and Penalty for Default.....	3
Section 5.	Waiver of Use or Abandonment of Unit	3
Section 6.	Enforcement	4
Section 7.	Liability of Mortgagee	5
Section 8.	Assessment Status upon Sale of Unit.....	5
Section 9.	Construction Liens.....	6
ARTICLE III	ARBITRATION.....	6
Section 1.	Arbitration.....	6
Section 2.	Right to Judicial Action.....	6
Section 3.	Effect of Election to Arbitrate	6
Section 4.	Mediation	6
ARTICLE IV	INSURANCE.....	7
Section 1.	Extent of Coverage; Responsibility for Coverage.....	7
Section 2.	Association as Attorney-in-Fact.....	8
ARTICLE V	RECONSTRUCTION OR REPAIR IN CASE OF CASUALTY	8
Section 1.	Determination of Reconstruction or Repair.....	8
Section 2.	Co-owner Responsibility for Reconstruction or Repair.....	9
Section 3.	Association Responsibility for Reconstruction or Repair of Common Elements	9
Section 4.	Timing	10
Section 5.	Responsibility for Amounts within Insurance Deductible or Otherwise Uninsured..	10
Section 6.	Eminent Domain	10
Section 7.	Notification to Mortgagees and Guarantors.....	11
ARTICLE VI	RESTRICTIONS	11
Section 1.	Use of Unit	11
Section 2.	Leasing and Rental	12
Section 3.	Alterations and Modifications	15
Section 4.	Conduct on the Condominium.....	16

Section 5.	Animals within the Condominium	16
Section 6.	Use of Common Elements	17
Section 7.	Obstruction of and Storage on Common Elements	18
Section 8.	Vehicles upon the Condominium.....	18
Section 9.	Prohibition of Certain Items upon the Condominium	19
Section 10.	Signs	19
Section 11.	Rules and Regulations Consistent with Condominium Act	19
Section 12.	Association Access to Units and Common Elements	19
Section 13.	Landscaping and Decoration of Common Elements	20
Section 14.	Co-owner Maintenance of Unit and Common Elements.....	20
Section 15.	Application of Restrictions to the Association.....	21
Section 16.	Cost of Enforcing Documents	21
Section 17.	Approvals Revocable	21
	ARTICLE VII MORTGAGES	21
Section 1.	Notification of Mortgage	21
Section 2.	Notification to Mortgagee of Insurance Company	21
Section 3.	Notification to Mortgagees and Guarantors.....	21
	ARTICLE VIII MEMBERSHIP AND VOTING.....	22
Section 1.	Association Membership	22
Section 2.	Voting.....	22
Section 3.	Action without Meeting	23
	ARTICLE IX MEETINGS	23
Section 1.	Place of Meetings.....	23
Section 2.	Quorum.....	23
Section 3.	Annual Meetings	23
Section 4.	Special Meetings.....	23
Section 5.	Notice of Meetings.....	24
Section 6.	Remote Communication Attendance; Remote Communication Meetings.....	24
Section 7.	Adjournment for Lack of Quorum	24
Section 8.	Minutes.....	24
	ARTICLE X BOARD OF DIRECTORS.....	24
Section 1.	Qualification and Number of Directors	24
Section 2.	Term of Directors.....	25
Section 3.	Powers and Duties.....	25
Section 4.	Professional Management	26
Section 5.	Vacancies	26
Section 6.	Removal of Directors	26
Section 7.	First Meeting of New Board.....	27

Section 8.	Regular Meetings	27
Section 9.	Special Meetings.....	27
Section 10.	Quorum and Voting.....	27
Section 11.	Action without Meeting	27
Section 12.	Closing of Board of Director Meetings to Members; Privileged Minutes	27
Section 13.	Remote Communication Participation	28
Section 14.	Fidelity Bond/Crime/Employee Dishonesty Insurance	28
ARTICLE XI OFFICERS		28
Section 1.	Designation	28
Section 2.	Appointment.....	28
Section 3.	Removal	28
Section 4.	President	28
Section 5.	Vice President.....	28
Section 6.	Secretary	29
Section 7.	Treasurer	29
ARTICLE XII FINANCES, BOOKS AND RECORDS.....		29
Section 1.	Fiscal Year	29
Section 2.	Banking; Investment of Funds.....	29
Section 3.	Co-owner's Share of Funds	29
Section 4.	Association Records and Books; Audit or Review.....	29
ARTICLE XIII INDEMNIFICATION		30
Section 1.	Indemnification of Directors, Officers and Volunteers	30
Section 2.	Directors' and Officers' Insurance	30
ARTICLE XIV COMPLIANCE.....		30
Section 1.	Compliance with Condominium Documents.....	30
Section 2.	Amendment	31
Section 3.	Definitions.....	31
ARTICLE XV REMEDIES FOR DEFAULT.....		31
Section 1.	Default by a Co-owner.....	31
Section 2.	Association's Right to Abate	31
Section 3.	Assessment of Fines.....	32
Section 4.	Failure to Enforce Rights	32
Section 5.	Cumulative Rights	32
Section 6.	Rights of Co-owners.....	32
ARTICLE XVI FINES.....		32
Section 1.	General.....	32
Section 2.	Procedures	32
Section 3.	Fines	33

Section 4. Collection of Fines.....	33
ARTICLE XVII SEVERABILITY	34

EXHIBIT A

AMENDED AND RESTATED BYLAWS OF HIDDEN HARBOR CONDOMINIUM

ARTICLE I ASSOCIATION OF CO-OWNERS

Section 1. The Association. Hidden Harbor Condominium, a residential Condominium located in the Township of Waterford, Oakland County, Michigan, shall be administered by Hidden Harbor Condominium Association (the "Association"). The Association is a nonprofit corporation that has been organized under the applicable laws of the State of Michigan. The Association is responsible for the management, maintenance, operation and administration of the Common Elements, easements and affairs of the Condominium, subject to and in accordance with the Condominium Documents and the laws of the State of Michigan. All Co-owners and all persons using or entering upon the Condominium or acquiring any interest in any Unit or the Common Elements are subject to the provisions and terms set forth in the Condominium Documents.

Section 2. Purpose of Bylaws. These Bylaws are designated as both the Condominium Bylaws, relating to the way the Condominium and the common affairs of the Co-owners shall be administered, as required by the Condominium Act, and the Association or Corporate Bylaws, governing the Association's operation as a corporate entity, as required by the Michigan Nonprofit Corporation Act.

ARTICLE II ASSESSMENTS

Section 1. Taxes and Assessments. The Association shall be assessed as the person or entity in possession of any tangible personal property of the Condominium owned or possessed in common by the Co-owners, and personal property taxes based on such tangible personal property are expenses of administration. Special assessments levied by the government and real property taxes shall be assessed against the individual Units and not on the Common Elements or any other part of the Condominium. Special assessments levied by the government and real property taxes in any year in which the property existed as an established Condominium on the tax day shall be assessed against the individual Unit, notwithstanding any subsequent vacation of the Condominium. The government's levying of all property taxes and special assessments shall comply with Section 131 of the Condominium Act.

Section 2. Expenses and Receipts of Administration. All costs incurred by the Association in satisfaction of any liability arising within, caused by or in connection with the Common Elements or the administration of the Condominium shall be expenses of administration, and all sums received as proceeds of, or pursuant to, any policy of insurance carried by the Association securing the interests of the Co-owners against liabilities or losses arising within, caused by or connected with the Common Elements or the administration of the Condominium shall be receipts of administration, within the meaning of Section 54(4) of the Condominium Act, except as modified by the specific assignment of responsibilities for costs contained in Article IV of the Amended and Restated Master Deed.

Section 3. Determination of Assessment. Assessments shall be determined in accordance with the following provisions:

A. **Annual Budget.** The Board of Directors shall establish an annual budget in advance for each fiscal year and the budget shall project all expenses for the forthcoming year that may be required for the proper operation, management and maintenance of the Condominium, including a reasonable allowance for contingencies. Any adopted budget shall include an allocation to a reserve fund for repairs and replacement of those Common Elements that must be replaced on a periodic basis, in accordance with subsection D below. Upon the Board of Director's adoption of an annual budget, copies of the budget shall be delivered to each Co-owner and the annual assessment for the year shall be established based upon that budget, although the failure to deliver a copy of the budget to each Co-owner shall not affect or in any way diminish the liability of any Co-owner for any existing or future assessments. Failure or delay of the Board of Directors to prepare or adopt a budget for any fiscal year shall not constitute a waiver or release in any manner of a Co-owner's obligation to pay the allocable share of the common expenses whenever they shall be determined. In the absence of any annual budget or adjusted budget each Co-owner shall continue to pay each installment at the rate established for the previous fiscal year until notified of any change in the installment payment which shall not be due until at least ten (10) days after a new annual or adjusted budget is adopted. Co-owners shall have a ten (10) day grace period commencing with notice from the Board of Directors in which to submit their new or adjusted assessment payment.

B. **Additional Assessments.** The Board of Directors has the authority to increase the annual assessment or to levy additional assessments as it deems necessary, provided the same are only for the following: (i) to meet deficits incurred or anticipated because current assessments are insufficient to pay the costs of operation and maintenance; (ii) to provide repairs or replacements of existing Common Elements; (iii) to provide additions to the Common Elements at a total annual cost not exceeding 5% of the Association's annual operating budget; or (iv) for any emergencies. The authority to levy assessments under this subsection is solely for the Association's benefit and is not enforceable by any Association creditors or the Co-owners except the Association may voluntarily and conditionally assign the right to levy assessments to any lender relating to any voluntary loan transaction the Association enters into.

C. **Special Assessments.** Special assessments, in addition to those described in subsections A and B above, may be made by the Board of Directors from time to time if approved by the Co-owners as provided in this subsection, to meet other Association requirements, including, but not limited to: (i) assessments to provide additions to the Common Elements at a total cost exceeding 5% of the Association's annual operating budget; or (ii) assessments for any other appropriate purpose not elsewhere described. Special Assessments as provided for by this subsection shall not be levied without the prior approval of more than a majority of all Co-owners in good standing. The authority to levy assessments under this subsection is solely for the Association's benefit and is not enforceable by any Association creditors or the Co-owners except the Association may voluntarily and conditionally assign the right to levy assessments to any lender relating to any voluntary loan transaction the Association enters into.

D. **Reserve Fund.** The Board of Directors shall maintain a reserve fund for major repairs and replacements of Common Elements and emergency expenditures. The reserve fund shall be in the amount of not less than ten percent (10%) of the Association's annual budget (excluding that portion of

the budget allocated to the reserve fund itself). At least two (2) Directors must sign any checks or provide written authorization before any funds may be drawn from the reserve fund account. The Association may increase or decrease the reserve fund but may not reduce it below ten percent (10%) of the Association's annual budget. The reserve must be funded at least annually from the proceeds of the annual assessments set forth in subsection A of this Section; however, the reserve may be supplemented by additional assessments in accordance with subsection B above if the Board determines it. The minimum standard required by this subsection may prove to be inadequate. The Board of Directors shall annually consider the needs of the Condominium to determine if a greater amount should be set aside in reserve or if additional reserve funds should be established for any other purposes. The Board may adopt rules and regulations as it deems desirable from time to time with respect to type and manner of investment, funding of the reserves, disposition of reserves or any other matter concerning the reserve account(s). A Co-owner selling a Unit shall not be entitled to any refund whatsoever from the Association with respect to any reserve account or other Association asset.

Section 4. Payment of Assessments and Penalty for Default. All assessments levied against the Co-owners to cover expenses of administration shall be apportioned among and paid by the Co-owners equally without increase or decrease for the existence of any rights to the use of a Unit's Limited Common Elements. Annual assessments shall be payable by Co-owners in twelve (12) monthly installments or in installments as may be provided by the Board in its sole discretion, commencing with acceptance of a deed to or a land contract vendee's interest in a Unit, or with the acquisition of fee simple title to a Unit by any other means. Additional and Special Assessments shall be payable as stated in the notice announcing their levy. The payment of an assessment shall be in default if the assessment, or any part of the assessment, is not paid to the Association in full on or before the due date for the payment, which shall be the first (1st) day of each calendar month or any other date the Board may establish from time to time for any assessment. Assessments in default shall bear interest at 7% or the highest rate allowed by law, whichever is less, until paid in full. In addition, all assessments, or installments of assessments, that remain unpaid 10 days after the due date (based on the postmark date), shall incur a uniform late charge of \$25.00 per month to compensate the Association for administrative costs incurred because of the delinquency. Without the necessity of amending these Bylaws, the Board of Directors may from time to time revise the date that late charges accrue and the amount and frequency of uniform late charges, and the Board of Directors may levy additional late fees for special and additional assessments, all pursuant to Article VI, Section 11 of these Bylaws. Once there is a delinquency in the payment of any assessment installment lasting for more than two months, the Board of Directors may accelerate the remaining unpaid installments of the assessment so that all unpaid installments are immediately due and payable. Each Co-owner (whether one or more persons) shall be personally liable for the payment of all assessments (including, without limitation, late fees, administrative fees and costs of collection and enforcement of payment, including actual attorneys' fees) levied against their Unit while the Co-owner has an ownership interest in the Unit. Payments on installments of assessments in default shall be applied as follows: first, to costs of collection and enforcement of payment, including attorney's fees; second, to any interest charges, fines, administrative fees and late fees on the installments; and third, to installments in default in order of their due dates.

Section 5. Waiver of Use or Abandonment of Unit. Co-owners shall not be exempt from liability for their contribution toward the expenses of administration by waiver of the use or enjoyment of any of the Common Elements or by the abandonment of their Unit.

Section 6. Enforcement.

A. **Lien.** Sums assessed to a Co-owner that are unpaid including, without limitation, fines assessed to a Co-owner pursuant to Article XVI of these Bylaws, together with interest on these sums, collection charges including attorneys' fees, late charges, and advances made by the Association for taxes or other liens to protect its lien, constitute a lien upon the Unit or Units owned by the Co-owner at the time of the assessment before other liens except tax liens on the Unit in favor of any state or federal taxing authority and sums unpaid on the first mortgage of record, except that past due assessments which are evidenced by a recorded notice of lien have priority over a mortgage recorded subsequent to the recording of the notice and affidavit of lien. The lien upon each Unit owned by the Co-owner shall be in the amount assessed against the Unit, plus a proportionate share of the total of all other unpaid assessments attributable to Units no longer owned by the Co-owner but which became due while the Co-owner had title to the Units. The lien may be foreclosed by judicial action or by advertisement in the name of the Condominium on behalf of the other Co-owners as provided below.

B. **Remedies.** The Association may enforce collection of delinquent assessments by a suit at law for a money judgment or by foreclosure of the lien that secures payment of assessments, or both. A Co-owner may not withhold or escrow assessments, and may not assert in an answer, or set-off to a complaint brought by the Association for nonpayment of assessments, the fact the Association or its agents have not provided services or management to a Co-owner. Except as provided in Article X, Section 1, a Co-owner in default or that is otherwise not in good standing shall not be qualified to run for or function as an Association officer or Director, shall not be entitled to vote so long as they are not in good standing, and shall not be entitled to utilize any of the General Common Elements; provided, however, this provision shall not operate to deprive any Co-owner of ingress or egress to and from their Unit. The Association may also discontinue the furnishing of any services to a Co-owner in default. In a judicial foreclosure action, a receiver may be appointed to collect a reasonable rental for the Unit from the Co-owner or any persons claiming under them, and if the Unit is not occupied by the Co-owner, to lease the Unit and collect and apply the rents received. The Association may also assess fines for late payment or nonpayment of assessments in accordance with Article XVI of these Bylaws. All remedies shall be cumulative and not alternative.

C. **Foreclosure of Lien.** Each Co-owner, and every other person who from time to time has any interest in the Condominium, shall be deemed to have granted to the Association the unqualified right to elect to foreclose the lien securing payment of assessments, costs and expenses, either by judicial action or by advertisement. The provisions of Michigan law pertaining to foreclosure of mortgages by judicial action and by advertisement, and Section 108 of the Condominium Act, as the same may be amended from time to time, are incorporated by reference for the purposes of establishing the alternative procedures to be followed in lien foreclosure actions and the rights and obligation of the parties to such actions. Further, each Co-owner and every other person who from time to time has any interest in the Condominium, shall be deemed to have authorized and empowered the Association to sell or to cause to be sold the Unit (and improvements) with respect to which assessments are delinquent and to receive, hold and distribute the proceeds of the sale in accordance with the priorities established by applicable law. Each Co-owner acknowledges that at the time of acquiring title to such Unit they were notified of this Section 6 and that they voluntarily, intelligently and knowingly waived notice of any proceedings brought by the Association to foreclose by advertisement the lien for nonpayment of assessments and a hearing on the same prior to the sale of the subject Unit.

D. Notice of Action. Notwithstanding the above, a foreclosure proceeding shall not be commenced until a written notice of lien is recorded and served in accordance with this Section. The notice of lien shall set forth (i) the amount due to the Association exclusive of interest, costs, attorneys' fees and future assessments, (ii) the legal description of the subject Unit, and (iii) the name of the Co-owner of record. The notice of lien shall be recorded in the Oakland County Register of Deeds, but it need not have been recorded as of the date of mailing to the delinquent Co-owner. The notice of lien shall be mailed to the delinquent Co-owner by first class mail, postage prepaid, addressed to the Co-owner at their last known address at least ten (10) days in advance of commencing the foreclosure proceeding. If the delinquency is not cured within the ten (10) day period, the Association may take any remedial action as may be available to it under the Condominium Documents or Michigan law.

E. Expenses of Collection. All expenses incurred in collecting unpaid assessments, including interests, fines, costs, actual attorneys' fees (not limited to statutory fees and including attorneys' fees and costs related to appellate court proceedings or that are incidental to any bankruptcy proceedings filed by the delinquent Co-owner or probate or estate matters, including monitoring any payments made by the bankruptcy trustee or the probate court or estate to pay any delinquency, and/or attorneys' fees and costs incurred incidental to any State or Federal Court proceeding filed by the Co-owner) and advances for taxes or other liens or costs paid by the Association to protect its lien, shall be chargeable to the Co-owner in default and shall be secured by the lien on their Unit.

Section 7. Liability of Mortgagee. Notwithstanding any other provisions of the Condominium Documents, the holder of any first mortgage covering a Unit, or the first mortgage holder's successors and assigns, that obtains title to the Unit pursuant to the foreclosure remedies provided in the mortgage, shall take the property free of any claims for unpaid assessments or charges against the mortgaged Unit which become due prior to the acquisition of title to the Unit (the date of the foreclosure sale) by such person or entity, except for claims for a pro rata share of the assessments or charges resulting from a pro rata reallocation of the assessments or charges to all Units including the mortgaged Unit, and except for claims evidenced by a Notice of Lien recorded prior to the recording of the first mortgage.

Section 8. Assessment Status upon Sale of Unit. Upon the sale or conveyance of a Unit, any unpaid assessments, interest, late fees, fines, costs and attorneys' fees against the Unit shall be paid out of the net proceeds of the sale price or by the purchaser in preference over any other assessments or charges of whatever nature except (a) amounts due the State of Michigan or any subdivision of the State for taxes or special assessments due and unpaid and (b) payments due under first mortgages having priority to the unpaid assessments. A purchaser or grantee of a Unit is entitled to a written statement from the Association setting forth the amount of unpaid assessments, interest, late fees, fines, costs and attorneys' fees outstanding against the Unit and the purchaser is not liable for any unpaid assessments, interest, late fees, fines, costs and attorneys' fees in excess of the amount set forth in the written statement, nor shall the Unit be subject to any lien for any amounts in excess of the amount set forth in the written statement. The Board of Directors may charge a reasonable administrative fee for preparing this written statement, which may be assessed to the Unit and collected in the same manner as the collection of assessments under Article II of these Amended and Restated Bylaws. Any purchaser or grantee who fails to request a written statement from the Association at least five (5) days before the

conveyance shall be liable for any unpaid assessments against the Unit together with interest, late fees, fines, costs and attorneys' fees incurred in connection with the collection of the assessments.

Section 9. Construction Liens. Construction liens attaching to any portion of the Condominium are subject to the following limitations and Section 132 of the Condominium Act:

A. Except as otherwise provided, a construction lien for work performed upon a Unit or upon a Limited Common Element may attach only to the Unit upon which the work was performed.

B. A construction lien for work the Association authorizes may attach to each Unit only to the proportionate extent the Co-owner of the Unit is required to contribute to the expenses of administration as provided by the Condominium Documents.

C. A construction lien may not arise or attach to a Unit for work performed on the Common Elements not contracted for by the Association.

ARTICLE III ARBITRATION

Section 1. Arbitration. Disputes, claims, or grievances arising out of or relating to the interpretation or application of the Condominium Documents or arising out of disputes among or between Co-owners shall, upon the written consent of the parties to the disputes, claims or grievances and written notice to the Association, be submitted to arbitration. The parties to the arbitration shall accept the arbitrator's decision as final and binding. The Commercial Arbitration Rules of the American Arbitration Association as amended and in effect from time to time are applicable to any arbitration.

Section 2. Right to Judicial Action. In the absence of the election and written consent of the parties pursuant to Section 1 above, neither a Co-owner nor the Association is precluded from petitioning the courts to resolve any disputes, claims or grievances.

Section 3. Effect of Election to Arbitrate. Election by the parties to submit any dispute, claim or grievance to arbitration precludes the parties from litigating the dispute, claim or grievance in the courts.

Section 4. Mediation. Regardless of the other remedies available under these Bylaws or the Condominium Act, the parties to any dispute may agree to mediate any disputes. In instances involving a dispute between two or more Co-owners that has been presented to the Association by the Co-owners, the Association may compel the disputing Co-owners to first mediate the dispute before the Association considers any other action. All compelled mediation shall be conducted by qualified outside mediators at the expense of the disputing Co-owners. In all other instances, mediation is totally voluntary and upon agreement of the disputing parties.

ARTICLE IV INSURANCE

Section 1. Extent of Coverage; Responsibility for Coverage.

A. Association Responsibilities.

(1) Casualty. The Association shall insure all Common Elements against fire, vandalism, malicious mischief, and other perils covered by a special form cause of loss endorsement, in an amount equal to one hundred percent (100%) of the current replacement cost of the insurable improvements, excluding foundation and excavation costs, and with a maximum deductible amount no greater than 5% of the face amount of the policy, all as determined annually by the Board of Directors. Such coverage shall include interior walls within any Unit and the pipes, wires, conduits and ducts contained within the interior walls. The Association's policy shall include a "Guaranteed Replacement Cost Endorsement" or a "Replacement Cost Endorsement" and, if the policy includes a coinsurance clause, an "Agreed Amount Endorsement." The policy shall also include an "Inflation Guard Endorsement," if available, and a "Building Ordinance and Law Endorsement."

(2) Liability, Worker's Compensation, Fidelity Bond, Directors and Officer, and Other Required Coverage. The Association shall also carry (a) liability insurance with coverage in the minimum amount of one million dollars (\$1,000,000.00) for a single occurrence pertinent to the ownership, use, and maintenance of the Common Elements, (b) worker's compensation insurance, if applicable, (c) fidelity bond or equivalent employee dishonesty/crime coverage in the minimum amount of a sum equal to three months aggregate assessments on all Units plus reserve funds on hand, with such fidelity bond or equivalent employee dishonesty/crime insurance covering all Association officers, directors, and employees and all other persons, including any management agent, handling or responsible for any monies received by or payable to the Association (it being understood that if the management agent or others cannot be added to the Association's coverage, they shall be responsible for obtaining the same type and amount of coverage on their own before handling any Association funds), (d) Directors and Officers Liability coverage, and (e) any other insurance as the Board of Directors deems advisable.

(3) Optional Umbrella Insurance. The Association may purchase as an expense of administration an umbrella insurance policy that covers any risk the Association is required to cover but was not covered due to lapse or failure to procure.

(4) Benefited Parties. All insurance shall be purchased by the Association for the Association's benefit, the Co-owners, and their mortgagees, as their interests may appear.

(5) Insurance Records. All non-sensitive and non-confidential information in the Association's records regarding Common Element insurance coverage shall be made available to all Co-owners and mortgagees upon written request and reasonable notice during normal business hours.

(6) Cost of Insurance. All premiums for insurance purchased by the Association shall be expenses of administration.

(7) Proceeds of Association Insurance Policies. Proceeds of all Association insurance policies shall be received by the Association and distributed to the Association and, net any applicable costs, fees, assessments or other amounts owed to the Association, the Co-owners; provided, however, whenever repair or reconstruction of the Condominium is required as provided in Article V of these Bylaws, the proceeds of any insurance that the Association receives as a result of any loss requiring repair or reconstruction shall be applied for such repair or reconstruction.

B. Co-owner Responsibilities. The Association's coverage is not intended to be complete as to all matters, and Co-owners have an obligation to provide certain coverage as outlined in this Article. Co-owners should consult with their insurance advisors to determine what additional insurance they must obtain upon their Units and Common Elements at their own expense in addition to the coverage carried by the Association. Each Co-owner shall obtain (i) all risk insurance coverage for (a) the interior of their Unit including, without limitation, all light fixtures, plumbing fixtures, cabinets, countertops, equipment, trim, floor coverings, wall coverings, window shades, drapes, and all appliances, whether free-standing or built-in, (b) all improvements and betterments to the Unit or its Limited Common Elements, and (c) personal property located within a Unit or elsewhere in the Condominium, and (ii) insurance coverage for (a) personal liability and property damage for occurrences within a Unit or upon Limited Common Elements for which the Co-owner is assigned responsibility under Article IV of the Amended and Restated Master Deed, and (b) alternative living expense in event of fire or other casualty, and the Association has absolutely no responsibility for obtaining such coverage. Co-owners are also advised to obtain insurance covering any insurance deductible or uninsured amount the Co-owner may be required to pay under Article V, Section 5 or Article VI, Section 14 of these Bylaws.

C. Waiver of Subrogation; Cross-Liability Endorsements. The Association and all Co-owners shall use their best efforts to see that all property and liability insurance carried by the Association or any Co-owner contains appropriate provisions whereby the insurer waives its right of subrogation as to any claims against any Co-owner or the Association. The Association's liability insurance shall, where appropriate, contain cross-liability endorsements to cover liability of the Co-owners as a group to another Co-owner.

Section 2. Association as Attorney-in-Fact. Each Co-owner is deemed to appoint the Association as their true and lawful attorney-in-fact to act regarding all matters concerning any insurance carried by the Association. Without limiting the generality of the previous sentence, the Association has full power and authority to purchase and maintain insurance, to collect and remit premiums, to collect proceeds and to distribute the same to the Association, the Co-owners and respective mortgagees, as their interests may appear, but subject to the Condominium Documents, to execute releases of liability, and to execute all documents and to do all things on behalf of the Co-owner and the Condominium as necessary or convenient to the accomplishment of the foregoing.

ARTICLE V RECONSTRUCTION OR REPAIR IN CASE OF CASUALTY

Section 1. Determination of Reconstruction or Repair. If the damaged property is a Common Element or a Unit, the property shall be rebuilt or repaired if any Unit is tenantable, unless it is determined by the affirmative vote of eighty percent (80%) of the Co-owners that the entire Condominium shall be terminated, and two-thirds (2/3rds) of all mortgagees of record have consented to

such termination, which mortgagee consent shall be solicited in accordance with Section 90a of the Condominium Act.

Section 2. Co-owner Responsibility for Reconstruction or Repair. Subject to Article VI, Section 14, regardless of the cause or nature of any damage or deterioration, including, but not limited to, instances in which the damage is incidental to or caused by (a) a Common Element for which the Association is responsible under Article IV of the Amended and Restated Master Deed, (b) the maintenance, repair, or replacement of any Common Element, (c) the Co-owner's own actions or the Co-owner's failure to take appropriate preventive action, or (d) the malfunction of any appliance, equipment, or fixture located within or serving the Unit, each Co-owner is responsible for the cost of repair, reconstruction and replacement of all items the Co-owner is assigned repair and replacement responsibility under Article IV, Section 2 of the Amended and Restated Master Deed including, without limitation, windows, door-walls, interior doors, floor coverings, window treatments, interior walls, wall coverings, interior trim, furniture, electrical fixtures, outlets, switches, circuit breakers, breaker box and panels serving the Unit, plumbing fixtures, hot water heaters, air conditioning units, furnaces and all appliances, whether free-standing or built-in. If damage to the Common Elements or to the interior walls within a Co-owner's Unit or to pipes, wire, conduits, ducts or other Common Elements within the interior walls is covered by insurance held by the Association, then the reconstruction and repair of those insured items shall be the responsibility of the Association in accordance with Section 3 of this Article. If any interior portion of a Unit is covered by insurance held by the Association for the benefit of the Co-owner, and the Association's carrier is responsible for paying a claim under Article IV of these Amended and Restated Bylaws, the Co-owner is entitled to receive the benefits of the coverage less any applicable costs, fees, assessments or other amounts owed to the Association, but only in the absence of Co-owner coverage for those items and only after the Co-owner has paid a proportionate share of the deductible, and any proceeds distributed to the Co-owner shall be used solely for necessary repairs. If the damage is only to an item that is the Co-owner's responsibility to repair, replace and insure, it shall be the Co-owner's responsibility to promptly repair such damage in accordance with these provisions. If the damage involves items that are both the Co-owner's and the Association's responsibility to repair, replace and insure, then the Association is responsible for reconstruction or repair in accordance with Section 3 of this Article, although the responsibility for costs shall be allocated in accordance with this Section and Section 3.

Section 3. Association Responsibility for Reconstruction or Repair of Common Elements. Subject to the responsibility of the individual Co-owners as outlined in Section 2 above and other provisions of these Bylaws or the Amended and Restated Master Deed applicable to such situations, the Association shall be responsible for the reconstruction and repair of the Common Elements. Under no circumstances will the Association be responsible for incidental or consequential damages to a Unit, Limited Common Element, or any other property that is the responsibility of a Co-owner, or to the contents of any Unit or the personal property of a Co-owner or Unit occupant. Immediately after a casualty causing damage to property for which the Association has the responsibility of maintenance, repair, or reconstruction, the Association shall obtain reliable and detailed estimates of the cost to place the damaged property in a condition as good as that existing before the damage. If the proceeds of insurance are not sufficient to defray the estimated costs of reconstruction or repair required to be performed by the Association, or if at any time during such reconstruction or repair, or upon completion of such reconstruction or repair, the funds for the payment of the costs thereof are insufficient,

assessments shall be made against all Co-owners for the cost of reconstruction and repair in sufficient amounts to provide funds to pay the estimated or actual costs of repair.

Section 4. Timing. If damage to Common Elements or a Unit adversely affects the appearance of the Condominium or deprives others from utilizing the Common Elements, the party responsible for the repair and reconstruction shall promptly perform and diligently proceed with the repair or replacement of the damaged property.

Section 5. Responsibility for Amounts within Insurance Deductible or Otherwise Uninsured. Notwithstanding any other provision of the Condominium Documents, and except to the extent that a lack of insurance results from a breach of the Association's or other Co-owner's duty to insure, the responsibility for damage to any portion of the Condominium that is within the limits of any applicable insurance deductible, unless waived, and for any other uninsured amount, shall be borne by the responsible Co-owner if the damage results from (a) the Co-owner's or their families', guests', agents' or invitees' failure to observe or perform any requirement of the Condominium Documents, (b) the Co-owner's or their families', guests', agents' or invitees' damage to or misuse of the Common Elements, or (c) casualties and occurrences, whether or not resulting from Co-owner negligence, involving items or Common Elements which are the Co-owner's responsibility to maintain, repair, or replace.

Section 6. Eminent Domain. Section 133 of the Condominium Act (to the extent not inconsistent with the following) and the following provisions shall control upon any taking by eminent domain:

A. Common Elements Taken by Eminent Domain. If any portion of the Common Elements is taken by eminent domain, the award shall be allowed to the Co-owners in proportion to their respective undivided interests in the Common Elements. The Association, acting through its Board of Directors, may negotiate on behalf of all Co-owners for any taking of the Common Elements and any negotiated settlement approved by more than two-thirds (2/3) of the Co-owners shall be binding on all Co-owners.

B. Unit Taken by Eminent Domain. If a Unit is taken by eminent domain, the undivided interest in the Common Elements applying to the Unit shall apply to the remaining Units, being allocated to them in proportion to their respective undivided interests in the Common Elements. The court shall enter a decree reflecting the reallocation of the undivided interest in the Common Elements as well as for the Unit, and the award shall include just compensation to the Co-owner of the Unit taken for the undivided interest in the Common Elements as well as for the Condominium Unit.

C. Partial Taking of a Unit. If portions of a Unit are taken by eminent domain, the court shall determine the fair market value of the portions of the Unit not taken. The undivided interest of the Unit in the Common Elements shall be reduced in proportion to the diminution in the fair market value of the Unit resulting from the taking. The portions of undivided interest in the Common Elements divested from the Co-owners of the Unit shall be reallocated among the other Units in proportion to their respective undivided interests in the Common Elements. A Unit partially taken shall receive the reallocation in proportion to its undivided interest as reduced by the court under this subsection. The court shall enter a decree reflecting the reallocation of undivided interests produced, and the award shall include just compensation to the Co-owner of the Unit partially taken for that portion of the undivided

interest in the Common Elements divested from the Co-owner and not revested in the Co-owner pursuant to the following subsection, as well as for that portion of the Unit taken by eminent domain.

D. Impossibility of Use of Portion of Unit Not Taken by Eminent Domain. If the taking of a portion of a Unit makes it impractical to use the remaining portion of that Unit for a lawful purpose permitted by the Condominium Documents, then the entire undivided interest in the Common Elements applying to that Unit shall apply to the remaining Units, being allocated to them in proportion to their respective undivided interests in the Common Elements. The remaining portion of that Unit shall be a Common Element. The court shall enter an order reflecting the reallocation of undivided interests produced, and the award shall include just compensation to the Co-owner of the Unit for the Co-owner's undivided interest in the Common Elements and for the entire Unit.

E. Future Expenses of Administration Applying to Units Taken by Eminent Domain. Votes in the Association and liability for future expenses of administration applying to a Unit taken or partially taken by eminent domain shall apply to the remaining Units, being allocated to them in proportion to their relative voting strength in the Association. A Unit partially taken shall receive a reallocation as though the voting strength in the Association was reduced in proportion to the reduction in the undivided interests in the Common Elements.

F. Condominium Continuation after the taking by Eminent Domain. If the Condominium continues after a taking by eminent domain, then the remaining portion of the Condominium shall be resurveyed and the Amended and Restated Master Deed amended accordingly. The amendment may be executed by an Association officer authorized by the Board of Directors without the necessity of execution or specific approval by any Co-owner, but only with the prior written approval of holders of two-thirds (2/3rds) of all first mortgage liens on individual Units.

G. Condemnation or Eminent Domain Proceeding. If any Unit or the Common Elements or any portion of a Unit or the Common Elements is subject to condemnation or eminent domain proceedings or is otherwise sought to be acquired by a condemning authority, the Association shall promptly notify each institutional holder of a first mortgage lien on any Units.

Section 7. Notification to Mortgagees and Guarantors. Upon written request submitted to the Association, the Association shall give the holder of any first mortgage and any guarantors of the mortgage covering any Unit timely written notice of any condemnation or casualty loss that affects either a material portion of the Condominium or the Unit securing the mortgage.

ARTICLE VI RESTRICTIONS

Section 1. Use of Unit.

A. Single Family Use. No Unit shall be used for other than single-family residential purposes as defined by Township of Waterford Zoning Ordinances, and the Common Elements shall be used only for purposes consistent with such use. No Co-owner shall carry on any business enterprise or commercial activities anywhere on the Common Elements or within the Units, including without limitation for profit or nonprofit daycare, adult foster care, nursing facilities, transitional housing, group

homes and similar enterprises; provided, that Co-owners shall be allowed to have home offices in their Units so long as the use does not (1) involve additional pedestrian or vehicular traffic by customers, users or beneficiaries of the services being performed and/or congestion within the Condominium, (2) utilize or involve the presence of any employees within the Unit other than the Unit occupants, (3) disturb other Co-owners, (4) involve additional expense to the Association (such as utility charges and insurance), (5) violate any other provision or restriction contained in the Condominium Documents, (6) involve the storage of bulk goods for resale, and (7) constitute a violation of any ordinances or regulations of the Township of Waterford.

B. Occupancy Restrictions. The number of persons allowed to occupy or reside in any Unit shall be governed by the restrictions and regulations of the International Property Maintenance Code or other codes or ordinances that may be adopted by the Township of Waterford from time-to-time governing occupancy. The restrictions shall automatically change, without the necessity of an amendment to these Bylaws, upon the adoption of alternative regulations by the Township of Waterford, so that all Unit occupancy shall be in accordance with all Township of Waterford regulations.

Section 2. Leasing and Rental.

A. Right to Lease.

(1) In General. A Co-owner may only lease a Unit for the same purposes as set forth in Article VI, Section 1, and only if the Co-owner (a) complies with this Section 2, (b) has followed the disclosure procedures contained in subsection C below, and (c) obtained the Board of Director's prior written approval as more fully set forth in this Section 2.

(2) Restrictions on Leasing. Except for those Units under an approved lease as of the effective date of the Amended and Restated Master Deed, the Board of Directors shall not grant approval if (a) the leasing of the Unit would result in any one person or entity (including affiliates or commonly owned entities) leasing more than 1 Unit at any given time, or (b) the leasing of the Unit would cause the total number of leased Units to exceed 25%. Co-owners who were permitted to lease their Units as of the effective date of the Amended and Restated Master Deed are entitled to continue leasing their Units despite the foregoing limitations on the number of Units that may be rented, provided the Condominium Documents are followed and an approved lease is on file with the Association prior to the effective date of the Amended and Restated Master Deed. If there is a sale or transfer of ownership of a leased Unit, or if a leased Unit is no longer being leased, being prepared for lease, or being held out or otherwise marketed for lease, all automatic rights to lease that Unit shall terminate and no further leasing of the Unit shall take place without first obtaining the Board's written approval in compliance with these provisions.

(3) Minimum Term; Compliance with Condominium Documents. Subject to subsections (1) and (2), no Co-owner shall lease less than an entire Unit, and all leases shall (i) be for an initial term of no less than one (1) year, (ii) require the lessee to comply with the Condominium Documents, and (iii) provide that failure to comply with the Condominium Documents constitutes a default under the lease.

(4) Transient Tenancies Prohibited. No Co-owner shall accommodate transient tenants or occupants. For purposes of this Section, “transient tenant or occupant” refers to a non-Co-owner occupying a Unit for less than one (1) year and who has paid consideration for the occupancy. No Co-owner shall allow their tenant to sublease the Unit.

(5) Incorporation of Condominium Document Provisions. The terms of all leases, occupancy agreements and occupancy arrangements shall incorporate, or be deemed to incorporate, all the Condominium Document provisions. The Association may require the use of a standard lease addendum to ensure compliance with the requirements of this Section.

B. Exception to 25% Leasing Limitation. Notwithstanding the provisions contained in subsection A above or anything to the contrary contained in the Condominium Documents, the Association recognizes that circumstances may arise beyond a Co-owner's control that may justify an exception to allow the temporary leasing of a single Unit, regardless of the 25% rental limitation. Therefore, under the following circumstances, but only for so long as the circumstances exist, and only so long as the Co-owner has occupied the Unit for the immediately preceding six (6) months and the leasing of the Unit will not result in that Co-owner or any related person or entity leasing more than 1 Unit, the Board may allow a Co-owner to lease their Unit even though 25% or more of the Units may already be leased:

(1) Relocation to Nursing Home. A Co-owner must relocate to a nursing home or similar facility for a period likely to exceed six (6) months;

(2) Relocation for Medical or Employment Purposes. A Co-owner must relocate for medical purposes (treatment, rehabilitation, or recuperation) or employment purposes for a period likely to exceed six (6) months;

(3) Mortgage Liens Exceed Unit Fair Market Value. A Co-owner or the estate of a Co-owner must rent a Unit due to an inability to sell the Unit without incurring a financial loss because of mortgage liens recorded against the Unit exceeding the fair market value of the Unit; or

(4) Similar Extenuating Circumstances. Any similar extenuating situation approved by the Board of Directors.

C. Procedures for Leasing. The leasing of Units shall conform to the following additional provisions:

(1) Disclosure. A Co-owner desiring to rent or lease a Unit, shall disclose that fact in writing to the Association at least ten (10) days before presenting a lease form to a potential lessee, and shall at the same time supply the Association with a copy of the exact lease form for its review for its compliance with the Condominium Documents. Each Co-owner shall, promptly following the execution of any approved lease of a Unit, forward a true copy of the fully executed lease to the Association. If no lease form is to be used, then the Co-owner shall supply the Association with the name and address of the potential lessee or other occupants, along with the amount and due dates of any rental or compensation payable to the Co-owner, and the term of the proposed occupancy arrangement. Co-

owners who do not live in their Unit must keep the Association informed of their current correct address and phone number.

(2) Administrative Fee. The Board of Directors may charge reasonable administrative fees for reviewing, approving and monitoring lease transactions in accordance with this Section as the Board may establish. Any administrative fees shall be assessed to and collected from the leasing Co-owner in the same manner as the collection of assessments under Article II of these Amended and Restated Bylaws.

(3) Compliance with Condominium Documents. Tenants or non-Co-owner occupants shall comply with the Condominium Documents.

(4) Default by Tenant or Non-Co-owner Occupant. If the Board determines that a tenant or non-Co-owner occupant failed to comply with the Condominium Documents, the Association shall take the following action:

(a) Notification. The Association shall notify the Co-owner by certified mail advising of the alleged violation.

(b) Time to Cure. The Co-owner has fifteen (15) days after receipt of the notice to investigate and correct the alleged tenant or non-Co-owner occupant breach or advise the Association that a violation has not occurred.

(c) Remedies. If after fifteen (15) days the Association believes the alleged breach is not cured or may be repeated, it may institute on its behalf or derivatively by the Co-owners on behalf of the Association an action for eviction against the tenant or non-Co-owner occupant for breach of the Condominium Documents. The relief set forth in this Section may be by summary proceeding, although the Association may pursue relief in any Court having jurisdiction and whether by summary proceeding or otherwise. The Association may hold the tenant, the non-Co-owner occupant and the Co-owner liable for any damages caused by the Co-owner, tenant or non-Co-owner occupants. The Co-owner shall be responsible for reimbursing the Association for all costs incurred because of a tenant's or non-Co-owner occupant's failure to comply with the Condominium Documents, including the pre-litigation costs and actual attorneys' fees incurred in obtaining their compliance with the Condominium Documents.

(5) Notice to Pay Rent Directly to Association. When a Co-owner is in arrears to the Association for assessments, the Association may give written notice of the arrearage to the Co-owner's tenant or non-Co-owner occupant. The tenant or non-Co-owner occupant, after receiving the notice, shall deduct from their rental payments to the Co-owner the arrearage and future assessments as they fall due and shall pay them to the Association. The deductions shall not be a breach of the rental agreement or lease by the tenant or non-Co-owner occupant. If the tenant or non-Co-owner occupant, after being so notified, fails or refuses to remit rent to the Association that is otherwise due the Co-owner, then the Association may (1) prohibit the tenant from utilizing any of the General Common Elements, (2) issue a statutory Notice to Quit for non-payment of rent, and enforce that notice by summary proceedings, and/or (3) initiate proceedings pursuant to Section 112(4)(b) of the Condominium Act.

D. Lender Exception. Notwithstanding anything to the contrary and except for the prohibition on transient tenancies, first mortgage lenders or first mortgagee guarantors in possession of a Unit following a default of a first mortgage, foreclosure, or deed or other arrangement in lieu of foreclosure shall not be subject to the restrictions contained in Section 2A above and which relate to the term of any lease or rental agreement.

E. Department of Veterans Affairs Exception. To the extent that any provision set forth in the Condominium Documents regarding leasing is inconsistent with the requirements of guaranteed or direct loan programs of the United States Department of Veterans Affairs, as set forth in chapter 37 of title 38, United States Code, or part 36 of title 38, Code of Federal Regulations (“DVA Financing”), the provision shall not apply to any Unit that is:

- (1) Encumbered by DVA Financing; or
- (2) Owned by the Department of Veterans Affairs.

F. Rent Loss Insurance Coverage. Those Co-owners that rent their Unit are advised to obtain insurance coverage for reimbursement of rental income that may be lost while the Unit is being repaired, rebuilt or is otherwise not capable of being occupied. The Association shall have no responsibility for obtaining coverage and Co-owners shall have no claim against the Association for lost rental income.

Section 3. Alterations and Modifications.

A. Approvals Required. No Co-owner may commence or make alterations in exterior appearance, make structural modifications to any Unit including interior walls through or in which there exist easements for support or utilities or make changes in the appearance or use of any of the Common Elements, including but not limited to, exterior painting, or the installation, alteration or replacement of windows, doors, door-walls, lights, awnings, shutters, or other exterior attachments or modifications, until plans and specifications acceptable to the Board showing the nature, kind, shape, height, materials, color scheme, location and approximate cost have first been submitted to and approved in writing by the Board. A copy of the plans and specifications, as finally approved, must be delivered to the Board. The Board has the right to refuse to approve any plans or specifications that are not suitable or desirable in its opinion for aesthetic or any other reasons. In passing upon the plans and specifications it has the right to take into consideration the suitability of the proposed structure, improvement or modification, the area upon which it is proposed to be constructed, and the degree of harmony with the entire Condominium. Neither the Association nor the Board shall have any liability for the approval or disapproval of any proposed installation, alteration or replacement. If the Board approves any modification or alteration application, any approval is subject to a recordable, written undertaking by the Co-owner acknowledging that installation, maintenance, repair, replacement and insuring of all the improvements are to be at the Co-owner's sole expense. The Board has the right to require a Co-owner to complete the installation of any approved improvements or modifications by a date certain. Any modifications or alterations that a Co-owner performs pursuant to this Section shall, if applicable, be performed by licensed and insured contractors and in accordance with all applicable governmental regulations and ordinances, including the requirement that proper permits be applied for and issued by appropriate governmental agencies.

B. Improvements or Modifications to Facilitate Access to or Movement within a Unit. The provisions contained in subsection A are subject to the applicable Condominium Act provisions governing improvements or modifications if the purpose of the improvement or modification is to facilitate access to or movement within the Unit for persons with disabilities under the circumstances provided for in the Condominium Act at MCL 559.147a, as may be amended from time to time.

C. Sound Conditioning. A Co-owner shall not damage, attach anything to, or alter walls between Units to compromise sound conditioning.

D. Installation of Antennas/Satellite Dishes. The installation of antennas, direct broadcast satellites and other technologies regulated by the Federal Communications Commission shall be in accordance with the Association's rules and regulations, which shall be construed so as not to violate applicable FCC regulations.

Section 4. Conduct on the Condominium. No harmful, improper or unlawful activity, including without limitation speeding or other vehicular infractions, shall be engaged in on or upon the Common Elements or any Unit, nor shall anything be done which may be or become an annoyance or a nuisance to the Co-owners, nor shall any unreasonably noisy activity be carried upon the Common Elements or any Unit. There shall not be maintained any device or thing of any sort whose normal activities or existence is in any way harmful, noisy, dangerous, unsightly, unpleasant or of a nature as may diminish or destroy the reasonable enjoyment of other Units. No Co-owner shall do or permit anything to be done or keep or permit to be kept on their Unit or on the Common Elements anything that will increase the rate of insurance on the Condominium without the Board's written approval and each Co-owner shall pay to the Association the increased cost of insurance premiums resulting from any such activity or the maintenance of any such condition. All applicable municipal codes and ordinances must be followed.

Section 5. Animals within the Condominium.

A. Number and Type. No more than 1 household pet shall be kept, maintained or allowed within any Unit. As used in this Section, "household pet" means a dog or cat. The term "animal" or "household pet" shall not include small animals, fish or birds that are constantly caged or in a tank. Reptiles and exotic pets (i.e., rare or unusual animals or animals generally thought of as wild and not typically kept as a household pet) are prohibited.

B. Restrictions Applicable to Animals; Responsibilities of Co-owners.

(1) The Board of Directors may require that Co-owners register their animals with the Association before the animal may be maintained on or within the Condominium.

(2) No animals may be kept or bred for any commercial purpose.

(3) No animal may be permitted to be housed outside of a Unit, in a pen or otherwise, nor shall animals be tied or restrained unattended outside or be allowed to be loose upon the Common Elements. All animals shall be leashed when outdoors with the leash being held and controlled by a

responsible person and otherwise in accordance with any Township of Waterford Ordinances that may apply.

(4) Each Co-owner shall be responsible for the immediate collection and disposition of all fecal matter deposited by any animal maintained by the Co-owner or their occupants, anywhere in the Condominium.

(5) Any animal permitted to be kept in the Condominium shall have such care and restraint as not to be obnoxious because of noise, odor or unsanitary conditions. No savage or dangerous animal of any type shall be kept on the Condominium. No animal that creates noise and can be heard on any frequent or continuing basis shall be kept in any Unit or on the Common Elements.

(6) Any Co-owner who causes or permits any animal to be brought, maintained or kept on the Condominium shall indemnify and hold harmless the Association for any loss, damage or liability, including attorneys' fees and costs, that the Association may sustain because of the presence of the animal on the Condominium, whether the animal is permitted or not. The Association may assess and collect from the responsible Co-owner all losses and damages in the manner provided in Article II of these Amended and Restated Bylaws.

(7) The Association may charge Co-owners maintaining animals a reasonable additional assessment to be collected in the manner provided in Article II if the Board determines the assessment necessary to defray the maintenance costs to the Association of accommodating animals within the Condominium.

(8) All animals kept in accordance with this Section shall be licensed by the municipal agency having jurisdiction, and proof of the animal's shots shall be provided to the Association upon request.

C. Association Remedies. The Association may, after notice and hearing and without liability, remove or cause to be removed any animal from the Condominium that the Board determines to be in violation of the restrictions imposed by this Section or by any applicable Association rules and regulations. The Board may adopt additional rules and regulations with respect to animals.

Section 6. Use of Common Elements.

A. Storage; Handling of Refuse. Co-owners and other users of the Condominium shall not use the Common Elements for storage of supplies, materials, personal property or trash or refuse of any kind, except as provided in the Condominium Documents. Trash shall be stored and handled in accordance with all applicable Association rules and regulations and Township of Waterford ordinances and Co-owners shall be responsible for the collection and proper disposal of trash (or the Association's costs collecting and disposing of the trash) dispersed about the Common Elements, regardless of the reason.

B. Unightly Conditions. No unsightly condition shall be maintained on or in any balcony, and only furniture and equipment consistent with ordinary balcony use shall be permitted to remain on these areas. The Common Elements shall not be used for the drying or airing of clothing or other fabrics.

In general, no activity shall be carried on nor condition maintained that detracts from or is detrimental to the Condominium's appearance.

C. General. The Common Elements and Units shall only be used for purposes for which they are reasonably and obviously intended. All municipal ordinances pertaining to the use of the Common Elements must be followed.

Section 7. Obstruction of and Storage on Common Elements. Except as otherwise expressly permitted in the Condominium Documents, the Common Elements, including, without limitation, roads and sidewalks, shall not be obstructed in any way. Except as otherwise expressly permitted in the Condominium Documents, no bicycles, toys, strollers, sports equipment or other personal property may be left unattended on the Common Elements; provided, however, that furniture and equipment consistent with ordinary balcony use may be placed on these areas.

Section 8. Vehicles upon the Condominium.

A. Permitted Vehicles in General. Except as otherwise provided in this Section or in the Association's rules and regulations, only currently licensed automobiles, motorcycles (if not objectionable due to excessive noise or irresponsible operation), non-commercial pickup trucks, SUVs, and passenger vans, which are used as an occupant's primary means of transportation and not for any commercial purposes and which do not exceed 21 feet in overall length, may be parked in the Condominium. Except as otherwise provided in this Section, no house trailers, commercial vehicles (as defined in subsection C below), boat trailers, watercraft, boats, motor homes, camping vehicles, camping trailers, trailers, snowmobiles, snowmobile trailers, recreational vehicles, off-road vehicles or all-terrain vehicles shall be parked or stored in the Condominium.

B. Temporary Presence. The Board of Directors has the discretion to issue rules and regulations permitting the temporary presence of recreational/leisure vehicles within the Condominium for purposes such as loading and unloading. The Association shall not be responsible for any damages, costs, or other liability arising from any failure to approve the parking of or to designate a parking area for such vehicles.

C. Commercial Vehicles. Commercial vehicles shall not be parked in or about the Condominium (except as above provided) unless parked in an area specifically designated for such vehicles or trucks by the Board, or while making deliveries or pickups in the normal course of business. For purposes of this Section, commercial vehicles shall include vehicles or trucks with a curb weight of more than 12,000 pounds, overall length in excess of 21 feet, or with more than two axles, vehicles with commercial license plates, vehicles with any commercial markings or advertising appearing on the exterior, vehicles not designed or intended for personal transportation, or any vehicle either modified or equipped with attachments, equipment or implements of a commercial trade, including, but not limited to, ladder or material racks, snow blades, tanks, spreaders, storage bins or containers, vises, commercial towing equipment or similar items. For purposes of this Section, passenger vans, SUVs and pickup trucks, used for primary transportation and not for commercial purposes shall not be considered commercial vehicles provided they do not meet the definition of a commercial vehicle contained in this Section. The Association shall not be responsible for any damages, costs, or other liability arising from any failure to approve the parking of such vehicles or to designate an area for parking such vehicles.

D. Standing Vehicles, Repairs. Nonoperational vehicles or vehicles with expired license plates shall not be parked on the Condominium without the Board's written approval. Nonemergency maintenance or repair of vehicles is not permitted on the Condominium without the Board's written approval.

E. Parking Restrictions. No person shall park a vehicle in violation of the Association's rules and regulations or in designated fire lanes. The Board of Directors may require that Unit occupants register their vehicles with the Association before the vehicle may be maintained on or within the Condominium.

F. Association Rights. Subject to Section 252k or Section 252l of the Michigan Vehicle Code (MCL §257.252k and MCL §257.252l), the Board may cause vehicles parked or stored in violation of this Section, or of any applicable Association rules and regulations, to be stickered and towed from the Condominium, and the cost of the removal may be assessed to, and collected from, the Co-owner responsible for the presence of the vehicle in the manner provided in Article II of these Amended and Restated Bylaws. The Co-owner shall be responsible for costs incurred in having a towing company respond, even if the vehicle is moved and properly parked before the towing contractor arrives at the Condominium. The Board may establish rules and regulations governing the parking and use of vehicles in the Condominium.

Section 9. Prohibition of Certain Items upon the Condominium. Except as otherwise set forth in the Association's rules and regulations as are published from time to time or as otherwise approved by the Board in writing, no Co-owner shall use, or permit any occupant, agent, employee, invitee, guest or family member to use any drones, firearms, air rifles, pellet guns, BB guns, bows and arrows, fireworks, slingshots or other similar projectiles or devices anywhere on the Condominium, nor shall any Co-owner use or permit to be brought onto the Condominium any unusually volatile liquids or materials deemed to be hazardous to life, limb, or property.

Section 10. Signs. Except for a U.S. flag no larger than 3' x 5' that is located in a Board-approved area, no flags, notices, advertisements, pennants or signs, including "for sale" and "open house" signs, shall be displayed which are visible from the exterior of a Unit without the Board's written permission, unless in conformance with the Association's rules and regulations.

Section 11. Rules and Regulations Consistent with Condominium Act. The Board may make and amend from time-to-time reasonable rules and regulations consistent with the Condominium Act, the Amended and Restated Master Deed, and these Bylaws, concerning the use of the Common Elements or the rights and responsibilities of the Co-owners and the Association with respect to the Condominium or the manner of the Association's or Condominium's operation. The Association shall furnish to all Co-owners all regulations and any amendments to the regulations, which shall become effective as stated in the regulation. Any regulation or amendment may be revoked at any time by the affirmative vote of more than fifty percent (50%) of all Co-owners in good standing.

Section 12. Association Access to Units and Common Elements. The Association or its authorized agents shall have access to each Unit and any Common Elements from time to time, during reasonable working hours, upon notice to the Co-owner, as may be necessary for the maintenance, repair

or replacement of any of the Common Elements. The Association or its agents shall also have access to each Unit and the Common Elements without notice as may be necessary to make emergency repairs to prevent damage to the Common Elements or to another Unit. Each Co-owner shall provide the Association means of access to their Unit and any Common Elements during all periods of absence and if the Co-owner fails to provide means of access, the Association may gain access in any manner as may be reasonable under the circumstances, including removing any obstructions or materials that restrict access, and shall not be liable to the Co-owner for any damage to their Unit or any Common Elements caused in gaining access, or for repairing, replacing or reinstalling any removed obstructions or materials in gaining access. No Co-owner shall in any way restrict access to any plumbing, water line, water line valves, water meters, sprinkler system valves or any other element that must be accessible to service the Common Elements or any element which affects an Association responsibility in any way. Should access to any facilities of any sort be required, the Association may remove any coverings or attachments of any nature that restrict access and will have no responsibility for repairing, replacing or reinstalling any materials, whether or not installation has been approved in accordance with the Condominium Documents, that are damaged in the course of gaining access, nor shall the Association be responsible for monetary damages of any sort arising out of actions taken to gain necessary access.

Section 13. Landscaping and Decoration of Common Elements. No Co-owner shall perform any landscaping or plant any trees, shrubs or flowers or place any ornamental materials, including but not limited to statuary, bird feeders, exterior lighting, rocks or boulders, fencing, holiday decorations or other decorative items upon the General or Limited Common Elements unless in conformance with the Association's rules and regulations on landscaping and decorations as are published from time to time or is otherwise approved by the Board in writing. Any Co-owner-installed landscaping shall be the Co-owner's responsibility to maintain unless the Board specifies otherwise in writing. If the Co-owner fails to adequately maintain the landscaping to the Association's satisfaction, the Association has the right to perform the maintenance and assess and collect from the Co-owner the cost in the manner provided in Article II of these Bylaws. The Co-owner shall also be liable for any damages to the Common Elements arising from the performance, planting or continued maintenance of the landscaping.

Section 14. Co-owner Maintenance of Unit and Common Elements.

A. **Maintain in Good, Safe, Clean and Sanitary Condition.** Each Co-owner shall maintain their Unit and any Common Elements for which they have maintenance responsibility in a good, safe, clean and sanitary condition. All Units must have operational smoke detectors and carbon monoxide detectors installed. Co-owners shall implement reasonable precautionary maintenance and winterization measures with respect to any vacant Unit, including arranging for regular inspections during the times when the Unit is vacant, as the Board of Directors from time to time may require.

B. **Damage.** Each Co-owner shall use due care to avoid damaging any of the Common Elements, including, but not limited to, the telephone, water, gas, plumbing, electrical, cable TV or other utility conduits and systems and any other Common Elements in any Unit which serve or which may affect any other Unit. Each Co-owner shall be responsible for damages or costs to the Association resulting from damage to or misuse of the Co-owner's Unit or any of the Common Elements by them, or their family, guests, agents or invitees, or by casualties and occurrences, whether or not resulting from Co-owner negligence, involving items or Common Elements that are the Co-owner's responsibility to maintain, repair and replace, unless the damages or costs are covered by primary insurance carried by

the Association, in which case there shall be no responsibility unless reimbursement to the Association is excluded by virtue of a deductible provision, in which case the responsible Co-owner shall bear the expense to the extent of the deductible amount. Each Co-owner shall indemnify the Association against all damages and costs, and any damages or costs to the Association, including actual attorneys' fees, may be assessed to the Co-owner and against the Co-owner's Unit, and shall be (1) secured by the lien on the Co-owner's Unit, (2) immediately be due and payable, and (3) collected in the manner provided in Article II of these Bylaws.

C. Reporting. Co-owners have the responsibility to report to the Association any Common Element which has been damaged or which is otherwise in need of maintenance, repair or replacement as soon as it is discovered.

Section 15. Application of Restrictions to the Association. None of the restrictions contained in this Article VI or elsewhere in the Condominium Documents shall apply to the Association's activities in furtherance of its powers and purposes set forth in the Condominium Documents or the Condominium Act.

Section 16. Cost of Enforcing Documents. All costs, damages, fines, expenses and actual attorneys' fees incurred or levied by the Association in enforcing the Condominium Documents against a Co-owner or their licensees or invitees, including without limitation the restrictions set forth in this Article VI, may be assessed to, secured by the lien on the Unit and collected from the responsible Co-owner or Co-owners in the manner provided in Article II of these Bylaws. This includes actual costs and legal fees incurred by the Association in investigating and seeking legal advice concerning violations and actual costs and legal fees incurred in court proceedings and responding to and defending actions relating to violations in small claims court, or any other court of competent jurisdiction.

Section 17. Approvals Revocable. Any approval granted by the Board is in the nature of a license. If a Co-owner is not in compliance with the conditions of any Board approval, the Board may revoke the approval upon thirty (30) days written notice.

ARTICLE VII MORTGAGES

Section 1. Notification of Mortgage. Any Co-owner who mortgages their Unit shall notify the Association of the name and address of the mortgagee, and the Association shall maintain the information in a book entitled "Mortgages of Units."

Section 2. Notification to Mortgagee of Insurance Company. Upon written request submitted to the Association, the Association shall notify a mortgagee appearing in the Mortgages of Units book of the name of each company insuring the Common Elements against fire and perils covered by extended coverage, and vandalism and malicious mischief and the amounts of coverage.

Section 3. Notification to Mortgagees and Guarantors. Upon written request submitted to the Association, any institutional holder of any mortgage or any guarantors of the mortgage covering any Unit is entitled to receive timely written notice of (i) any proposed action that requires the consent of a specified percentage of mortgagees, whether contained in the Amended and Restated Master Deed

or these Bylaws, (ii) any delinquency in the payment of assessments or other charges by a Co-owner that is not cured within sixty (60) days, and (iii) any lapse, cancellation or material modification of any insurance policy maintained by the Association.

ARTICLE VIII MEMBERSHIP AND VOTING

Section 1. Association Membership. Each Co-owner is a member of the Association and no other person is entitled to membership.

Section 2. Voting.

A. Voting Rights. Except as limited in these Bylaws, each Co-owner is entitled to one vote for each Unit owned, provided the Co-owner is in good standing. Voting shall be by number. In the case of any Unit owned by more than one Co-owner, the voting rights associated with that Unit may be exercised only as a single vote. The vote of each Co-owner may be cast only by the individual representative designated by the Co-owner in the notice required in subsection C below or by a proxy given by the individual representative.

B. Evidence of Ownership for Voting Purposes. No Co-owner is entitled to vote at any Association meeting until they have presented evidence of ownership of a Unit to the Association by way of a recorded Deed, recorded Land Contract or recorded Memorandum of Land Contract.

C. Designation of Voting Representative. Each Co-owner shall file a written notice with the Association designating the individual representative who shall vote at Association meetings and receive all notices and other Association communications on behalf of the Co-owner. The notice shall state the name and address of the individual representative designated, the number or numbers of the Unit or Units owned by the Co-owner, and the name and address of each person that is the Co-owner. The Co-owner shall sign and date the notice. The Co-owner may change the individual representative designated at any time by filing a new notice in the manner provided in this subsection. At any Association meeting or where action is taken without a meeting in accordance with these Amended and Restated Bylaws, the chairperson of the meeting or the Board may waive the filing of the written notice as a prerequisite to voting.

D. Voting Method. Votes may be cast in person, by proxy, in writing signed by the designated voting representative, or by any other means allowed by the voting procedures adopted by the Board of Directors for a given vote. The Board of Directors may permit the casting of votes by mail, personal delivery, electronic transmission, or by other Board-approved means. Any proxies, written votes or ballots or other votes cast by permitted means must be filed with the Association's Secretary or the Association's management agent at or before the appointed time of the Association meeting or voting deadline if no meeting is held.

E. Majority. Unless otherwise provided, any action that could be authorized at an Association meeting or by written vote or ballot shall be authorized by the vote of a simple majority of those Co-owners in good standing.

Section 3. Action without Meeting. Any action that may be taken at an Association meeting (except for electing or removing Directors) may be taken without a meeting by written vote or ballot of the Co-owners. Written votes or ballots shall be solicited in the same manner as provided in these Bylaws for the giving of notice of Association meetings. All solicitations shall specify: (1) the proposed action; (2) that the Co-owner can vote for or against any proposed action; (3) the percentage of approvals necessary to approve the action; and (4) the time by which written votes or ballots must be received to be counted. Approval by written vote or ballot shall be constituted by receipt, within the time specified in the written vote or ballot, of a number of approvals that equals or exceeds the number of votes that would be required for approval if the action were taken at a meeting. Only the Board of Directors may initiate an action under this Section.

ARTICLE IX MEETINGS

Section 1. Place of Meetings. Association meetings shall be held at any suitable place convenient to the Co-owners as the Board may designate. Association meetings shall be guided by Roberts Rules of Order or some other generally recognized manual of parliamentary procedure when not otherwise in conflict with the Articles of Incorporation, the Amended and Restated Master Deed or the laws of the State of Michigan. Co-owners must be in good standing to speak at Association meetings or to address the Board or Co-owners at any Association meetings. Any person in violation of this provision or the rules of order governing the meeting may be removed from the meeting, without any liability to the Association or its Board of Directors.

Section 2. Quorum. The presence in person or by proxy of 35% of the Co-owners in good standing constitutes a quorum for holding an Association meeting. The written vote or ballot of any person furnished at or prior to any Association meeting at which meeting the person is not otherwise present in person or by proxy, or by the date as is established for voting in cases where no meeting is held, shall be counted in determining the presence of a quorum with respect to the question upon which the vote is cast. Any Co-owner who participates by remote communication in an Association meeting, as provided in Article IX, Section 6 below, shall also be counted in determining the necessary quorum.

Section 3. Annual Meetings. The Association shall hold its annual meeting in the month of March each succeeding year at a date, time and place as the Board of Directors determines. The Board may change the date of the annual meeting in any given year, provided that at least one meeting is held in each calendar year. At the annual meeting, there shall be elected by ballot or acclamation of the Co-owners a Board of Directors in accordance with the requirements of Article X of these Bylaws. The Co-owners may also transact at annual meetings any other Association business as may properly come before them.

Section 4. Special Meetings. The President shall call a special meeting of the Co-owners as directed by Board resolution. The President shall also call a special meeting upon a petition presented to the Association's Secretary that is signed by one third (1/3rd) of those Co-owners in good standing. Notice of any special meeting shall state the time, place and purpose of the meeting. No business shall be transacted at a special meeting except as stated in the notice.

Section 5. Notice of Meetings. The Secretary or other Board authorized person shall serve each Co-owner a notice of each annual or special meeting, stating the purpose as well as the time and place where it is to be held, at least ten (10) days, but not more than sixty (60) days, prior to the meeting. Notice of Association meetings shall be mailed to the representative of each Co-owner at the address shown in the notice required to be filed with the Association pursuant to Article VIII, Section 2C of these Bylaws or to the address of the Co-owner's Unit or, in lieu of the foregoing, notice may be given by electronic transmission, or notice may be hand delivered to a Unit if the Unit address is designated as the voting representative's address or the Co-owner is a resident of the Unit. Any Co-owner may, by written waiver of notice signed by the Co-owner, waive the notice, and the waiver when filed in the Association's records shall be deemed due notice.

Section 6. Remote Communication Attendance; Remote Communication Meetings. Co-owners may participate in Association meetings by a conference telephone or by other means of remote communication through which all persons participating in the meeting may hear each other, if the Board determines to permit the participation and (a) the means of remote communication permitted are included in the notice of the meeting or (b) if notice is waived or not required. All participants shall be advised of the means of remote communication in use and the names of the participants in the meeting shall be disclosed to all participants. Co-owners participating in a meeting by means of remote communication are considered present in person and may vote at the meeting if all of the following are met: (a) the Association implements reasonable measures to verify that each person considered present and permitted to vote at the meeting by means of remote communication is a Co-owner or proxy holder; (b) the Association implements reasonable measures to provide each Co-owner and proxy holder a reasonable opportunity to participate in the meeting and to vote on matters submitted to the Co-owners, including an opportunity to read or hear the proceedings of the meeting substantially concurrently with the proceedings; and (c) if any Co-owner or proxy holder votes or takes other action at the meeting by means of remote communication, the Association maintains a record of the vote or other action. A Co-owner may be present and vote at an adjourned Association meeting by means of remote communication if they were permitted to be present and vote by the means of remote communication in the original meetings notice given. The Board may hold an Association meeting conducted solely by means of remote communication.

Section 7. Adjournment for Lack of Quorum. If any meeting of Co-owners cannot be held because a quorum is not in attendance, the Co-owners who are present may adjourn the meeting to a time not less than forty-eight (48) hours from the time the original meeting was called.

Section 8. Minutes. The Association shall keep minutes or a similar record of the proceedings of all Association meetings and, when signed by the President or Secretary, shall be presumed truthfully to evidence the matters set forth therein. A recitation in the minutes of any meeting that notice of the meeting was properly given shall be prima facie evidence that the notice was given.

ARTICLE X BOARD OF DIRECTORS

Section 1. Qualification and Number of Directors. The Board of Directors shall govern the Association's affairs. The Board shall consist of five (5) members. All Directors must be Co-owners, trustees of trusts owning Units or officers, directors, members or employees of business entities owning

Units. No two Co-owners of the same Unit may serve on the Board of Directors at the same time. Any Director who is delinquent in any financial obligation owed to the Association, including late fees, shall pay in full the amount due within sixty (60) days of the delinquency. During the period of delinquency, the Director is not permitted to vote on any delinquency matter, including any delinquency matter pertaining to that Director. If the Director does not comply within the delinquency cure period, and notwithstanding Section 6 below, the Director shall be deemed removed from the Board of Directors for the remainder of the Director's term and the vacancy shall be filled in accordance with Section 5 below. Directors shall serve without compensation.

Section 2. Term of Directors. At the first annual meeting following adoption of these Amended and Restated Bylaws, all Directors shall stand for election as a single slate. The three Directors receiving the highest number of votes shall be elected for a term of two years. The two Directors receiving the next highest number of votes shall be elected for a term of one-year. In each year thereafter, either two or three Directors shall be elected for two-year terms depending on how many directorships expire that year. All Directors shall hold office until their successors have been elected and hold their first meeting.

Section 3. Powers and Duties. The Board of Directors has all powers and duties necessary for the administration of the Association's affairs and may do all acts and things as are not prohibited by the Condominium Documents or required to be exercised and done by the Co-owners. In addition to the foregoing general powers and duties imposed by these Bylaws, or any further powers and duties which may be imposed by law or the Articles of Incorporation, the Board of Directors has the following powers and duties:

A. **Management and Administration.** To manage and administer the affairs of and maintenance of the Condominium and the Common Elements, all to the extent set forth in the Condominium Documents.

B. **Collecting Assessments.** To collect assessments from the Co-owners and to use the proceeds for the Association's purposes.

C. **Insurance.** To carry insurance and collect and allocate the proceeds in the manner set forth in Article IV.

D. **Rebuild Improvements.** To rebuild improvements after casualty in the manner set forth in Article V.

E. **Contract and Employ Persons.** To contract for and employ persons, firms, corporations or other agents to assist in the management, operation, maintenance and administration of the Condominium.

F. **Real or Personal Property.** To acquire, maintain and improve, and to buy, operate, manage, sell, convey, assign, mortgage or lease any real or personal property (including any Unit and any easements, rights-of-way and licenses) on the Association's behalf in furtherance of any Association purposes.

G. Borrow Money. To borrow money and issue evidence of indebtedness in furtherance of any and all of the purposes of the Association's business, and to secure the same by mortgage, pledge, or other lien on property owned by the Association.

H. Assign Right to Future Income. To assign its right to future income, including the right to receive Co-owner assessment payments.

I. Rules and Regulations. To make rules and regulations in accordance with Article VI, Section 11 of these Bylaws.

J. Committees. To establish committees as it deems necessary, convenient or desirable and to appoint persons to the committees for implementing the administration of the Condominium and to delegate to the committees, or any specific Association Officers or Directors, any functions or responsibilities which are not by law or the Condominium Documents required to be performed by the Board.

K. Enforce Documents. To enforce the Condominium Documents.

L. Administrator. To do anything required of or permitted to the Association as administrator of the Condominium under the Condominium Documents.

M. General. In general, to enter any kind of activity, to make and perform any contract and to exercise all powers necessary, incidental or convenient to the administration, management, repair, replacement and operation of the Condominium and the Association.

Section 4. Professional Management. The Board of Directors may employ for the Association a professional management agent at reasonable compensation established by the Board to perform those duties and services as the Board shall authorize, including, but not limited to, the duties listed in this Article. The Board may delegate to the management agent any other duties or powers which are not by law or by the Condominium Documents required to be performed by or have the approval of the Co-owners. The Board shall not be authorized to enter into any contract with a professional management agent in which the maximum term is greater than three (3) years, or which is not terminable by the Association upon ninety (90) days' written notice to the other party.

Section 5. Vacancies. Vacancies in the Board of Directors caused by any reason other than the removal of a Director by Co-owner vote shall be filled by majority vote of the remaining Directors even though they may constitute less than a quorum. Each person so appointed shall be a Director until a successor is elected at the Association's next annual meeting.

Section 6. Removal of Directors. At any annual or special Association meeting duly called and held, any one or more of the Directors may be removed with or without cause by the affirmative vote of more than 50% of all Co-owners in good standing, and a successor may then and there be elected to fill the vacancy created, with the successor Director serving until the end of the term of the Director who they replaced. The quorum requirement for filling any vacancy shall be the normal 35% of the Co-owners in good standing. Any Director whose removal has been proposed by the Co-owners shall have an opportunity to be heard at the meeting.

Section 7. First Meeting of New Board. The first meeting of a newly elected Board shall be held within ten (10) days of election at a place and time as shall be fixed by the Directors at the meeting at which the Directors were elected. No notice shall be necessary to the newly elected Directors to legally constitute such meeting, provided a majority of the entire Board is present at such a meeting.

Section 8. Regular Meetings. Regular Board of Directors meetings may be held at times and places as shall be determined from time-to-time by a majority of the Directors. At least two (2) meetings shall be held during each fiscal year. Notice of regular Board meetings shall be given to each Director personally, or by mail, telephone or electronic transmission at least ten (10) days prior to the date of the meeting, unless waived by the Director.

Section 9. Special Meetings. Special meetings of the Board of Directors may be called by the president upon five (5) days' notice to each Director. Notice of special Board meetings shall be given to each Director personally, or by mail, telephone or electronic transmission. The notice shall state the time, place and purpose of the meeting. Special meetings of the Board of Directors shall be called by the president, secretary or other appropriate officer in like manner and on like notice on the written request of two Directors.

Section 10. Quorum and Voting. The presence of a majority of the Directors at a meeting constitutes a quorum for the transaction of business, and the acts of the majority of the Directors present at a meeting at which there is a quorum shall be the acts of the Board of Directors. A Director will be considered present and may vote on matters before the Board by remote communication, electronically or by any other method giving the remainder of the Board sufficient notice of the absent Director's vote and position on any given matter. If at any Board meeting there is less than a quorum present, the majority of those present may adjourn the meeting. At any such adjourned meeting where quorum is present, any business that might have been transacted at the meeting as originally called may be transacted without further notice.

Section 11. Action without Meeting. Any action permitted to be taken by the Board of Directors at a meeting of the Board shall be valid in the absence of a meeting if consented to in writing, including by electronic transmission, by a majority of the Board of Directors; provided, that all Board members must first be provided with notice personally, by mail, telephone or electronic transmission, of the proposed action before any action is approved. Further, the presiding Association officer, in exceptional cases requiring immediate action, may poll all Directors by phone for a vote, and provided the action is consented to by the requisite number of Directors, the vote constitutes valid action by the Board. The results of any vote along with the issue voted upon pursuant to this Section shall be noted in the minutes of the next Board meeting to take place.

Section 12. Closing of Board of Director Meetings to Members; Privileged Minutes. The Board of Directors, in its discretion, may close a portion or all of any meeting of the Board of Directors to the Co-owners or may permit Co-owners to attend a portion or all of any meeting of the Board of Directors. Any Co-owner has the right to inspect, and make copies of, the minutes of Board meetings; provided, however, and subject to any Association rules and regulations, that no Co-owner is entitled to review or copy any Board meeting minutes to the extent the minutes reference any matter for which the disclosure would impair the rights of another, any privileged communications between the Board of

Directors and counsel for the Association, or any other matter to which a privilege against disclosure pertains under Michigan Statute, common law, the Michigan Rules of Evidence, or the Michigan Court Rules.

Section 13. Remote Communication Participation. Board members may participate in any meeting by means of conference telephone or other means of remote communication through which all persons participating in the meeting can communicate with the other participants. Participation in a meeting by these means constitutes presence in person at the meeting.

Section 14. Fidelity Bond/Crime/Employee Dishonesty Insurance. The Board of Directors shall obtain fidelity bond or equivalent employee dishonesty/crime coverage in the minimum amount of a sum equal to three months aggregate assessments on all Units plus reserve funds on hand. The fidelity bond or equivalent employee dishonesty/crime insurance covering all officers, directors, and employees of the Association and all other persons, including any management agent, handling or responsible for any monies received by or payable to the Association (it being understood that if the management agent or others cannot be added to the Association's coverage, they shall be responsible for obtaining the same type and amount of coverage on their own before handling any Association funds). The premiums for the foregoing shall be expenses of administration.

ARTICLE XI OFFICERS

Section 1. Designation. The principal Association officers are a president, vice president, secretary and treasurer. The Directors may appoint other officers as may be necessary. Any two offices except that of president and vice president may be held by one person. The President must be a member of the Board of Directors. Officers shall serve without compensation.

Section 2. Appointment. The Board of Directors shall appoint the Association's officers annually and all officers shall hold office at the Board's pleasure.

Section 3. Removal. The Board of Directors may remove any officer either with or without cause, and the successor to the removed officer may be elected at any regular Board meeting or at any special Board meeting called for such purpose.

Section 4. President. The president shall be the Association's chief executive officer and shall preside at all Association and Board meetings. The president has all the general powers and duties which are usually vested in the office of the president of a nonprofit corporation including, but not limited to, the power to appoint committees from among the Co-owners from time to time in the president's reasonable discretion to assist in the conduct of the Association's affairs.

Section 5. Vice President. The vice president shall take the place of the president and perform the president's duties whenever the president is absent or unable to act. If neither the president nor the vice president can act, the Board of Directors shall appoint some other Board member to so do on an interim basis. The vice president also shall perform those other duties as shall from time to time be imposed by the Board of Directors.

Section 6. Secretary. The secretary shall keep the minutes of all Board and Association meetings, be responsible for maintaining a record of the minutes and of any books and other records as the Board of Directors may direct and shall in general perform all duties incident to the office of the secretary. The Board may delegate the duties of the secretary to a management agent.

Section 7. Treasurer. The treasurer is responsible for keeping full and accurate accounts of all receipts and disbursements in the Association's books. The treasurer also shall be responsible for depositing all money and other valuable Association papers, in the name of and to the Association's credit, in depositories the Board may designate from time to time. The Board may delegate the duties of the treasurer to a management agent.

ARTICLE XII FINANCES, BOOKS AND RECORDS

Section 1. Fiscal Year. The Association's fiscal year shall be an annual period commencing on a date as the Board may initially determine. The commencement date of the Association's fiscal year is subject to change by the Board of Directors for accounting reasons or other good cause.

Section 2. Banking; Investment of Funds. Association funds shall be deposited in a bank, credit union, or other depository as the Board may designate and shall be withdrawn only upon the check or order of such officers, employees or agents as are designated by Board resolution from time to time. Association funds shall only be held in accounts that are fully insured or backed by the full faith and credit of the United States Government. The Association may only invest in certificates or instruments that are fully insured or backed by the full faith and credit of the United States Government.

Section 3. Co-owner's Share of Funds. A Co-owner's share in the Association's funds and assets cannot be assigned, pledged or transferred in any manner except as a Unit appurtenance.

Section 4. Association Records and Books; Audit or Review.

A. **Association Records and Books.** The Association shall maintain current copies of the Condominium Documents. The Association shall also keep detailed books of account showing all expenditures and receipts of administration, which shall specify the maintenance and repair expenses of the Common Elements and any other expenses incurred by or on the Association's behalf and the Co-owners. The Association's books shall be maintained in accordance with Section 57 of the Condominium Act. Subject to any Association rules and regulations, the books, records, contracts, and financial statements concerning the administration and operation of the Condominium shall be open for inspection by the Co-owners and their mortgagees during reasonable working hours and at mutually convenient times. The Association shall prepare and distribute to each Co-owner at least one (1) time a year a financial statement, the contents of which shall be defined by the Board and which may be distributed by electronic transmission, provided that any Co-owner may receive a written financial statement upon written request. Any institutional holder of a first mortgage lien on any Unit is entitled to receive a copy of the annual financial statement within ninety (90) days following the end of the Association's fiscal year if requested in writing.

B. Audit or Review. The Association shall have its books, records and financial statements independently audited or reviewed on an annual basis by a certified public accountant, as defined in Section 720 of the occupational code (MCL 339.720); provided, however, that the Association may opt out of a certified audit or review on an annual basis by an affirmative vote of a majority of the Co-owners in good standing. Any audit or review shall be performed in accordance with the statements on auditing standards or the statements on standards for accounting and review services, respectively, of the American Institute of Certified Public Accountants.

ARTICLE XIII INDEMNIFICATION

Section 1. Indemnification of Directors, Officers and Volunteers. The Association shall indemnify every Director, officer and volunteer of the Association against all expenses and liabilities, including reasonable attorney fees and amounts paid in settlement incurred by or imposed upon the Director, officer or volunteer in connection with any threatened, pending or completed action, suit or proceeding, whether civil, criminal, administrative or investigative and whether formal or informal, to which the Director, officer or volunteer may be a party or in which they may become by reason of their being or having been a Director, officer or volunteer of the Association, whether or not they are a Director, officer or volunteer at the time the expenses are incurred, so long as the person acted in good faith and in a manner they reasonably believed to be in or not opposed to the Association's best interests and, with respect to any criminal action or proceeding, had reasonable cause to believe that their conduct was lawful; provided, however, that the Association shall not indemnify any person with respect to any claim, issue, or matter as to which the person has been finally adjudged to be liable for gross negligence or willful and wanton misconduct in the performance of his duty to the Association unless and only to the extent that a court shall determine upon application that, despite the adjudication of liability but in view of all the circumstances of the case, the person is fairly and reasonably entitled to indemnification for those expenses as the court shall deem proper. The foregoing right of indemnification shall be in addition to and not exclusive of all other rights to which the Director or officer may be entitled. The Board of Directors shall notify all Co-owners of payment of any indemnification that it has approved at least ten (10) days before payment is made. The indemnification rights of this Article shall be construed to be consistent with those contained in the Association's Articles of Incorporation.

Section 2. Directors' and Officers' Insurance. The Association shall provide liability insurance for every Director and every officer of the Association for the same purposes provided above in Section 1 and in amounts as may reasonably insure against potential liability arising out of the performance of their respective duties. No Director or officer shall collect for the same expense or liability under Section 1 above and under this Section 2; however, to the extent the liability insurance provided to a Director or officer is inadequate to pay any expenses or liabilities otherwise properly indemnifiable under the terms of this Article, a Director or officer shall be reimbursed or indemnified only for the excess amounts under Section 1 above or other applicable statutory indemnification.

ARTICLE XIV COMPLIANCE

Section 1. Compliance with Condominium Documents. The Association and all present or future Co-owners, tenants, future tenants, or any other persons acquiring an interest in or using the

Condominium in any manner are subject to and shall comply with the Condominium Act and the Condominium Documents. If the Amended and Restated Master Deed, these Bylaws, or Articles of Incorporation conflict with any Statute, the Statute shall govern. If any provision of these Bylaws conflicts with any provision of the Amended and Restated Master Deed, the Amended and Restated Master Deed shall govern.

Section 2. Amendment. These Bylaws may be amended in accordance with the Condominium Act and Article VIII of the Amended and Restated Master Deed.

Section 3. Definitions. All terms used in these Amended and Restated Bylaws have the same meaning as set forth in the Amended and Restated Master Deed, or as set forth in the Condominium Act.

ARTICLE XV REMEDIES FOR DEFAULT

Section 1. Default by a Co-owner. Any Co-owner default shall entitle the Association or another Co-owner or Co-owners to the following relief:

A. Remedies for Default by a Co-owner to Comply with the Documents. Failure to comply with the Condominium Documents shall be grounds for relief, which may include without intending to limit the same, an action to recover sums due for damages, injunctive relief, foreclosure of lien or any combination of the foregoing, and such relief may be sought by the Association, or, if appropriate, by an aggrieved Co-owner or Co-owners.

B. Costs Recoverable from Co-owner. A Co-owner's, non-Co-owner occupant's or guest's failure to comply with the Condominium Documents shall entitle the Association to recover from such Co-owner or non-Co-owner resident or guest the pre-litigation costs and actual attorneys' fees incurred in obtaining their compliance with the Condominium Documents, including actual costs and legal fees incurred by the Association in investigating and seeking legal advice concerning violations and actual costs and legal fees incurred in any court proceedings. In addition, in any proceeding arising because of an alleged default by any Co-owner, or in cases where the Association must defend an action brought by any Co-owner(s) or non-Co-owner residents or guests, including proceedings in the appellate courts, and regardless if the claim is original or brought as a defense, a counterclaim, cross claim or otherwise, the Association, if successful, is entitled to recover from such Co-owner or non-Co-owner resident or guest pre-litigation costs, the costs of the proceeding and actual attorney's fees (not limited to statutory fees), incurred in defense of any claim or obtaining compliance or relief, but in no event shall any Co-owner be entitled to recover such attorney's fees or costs against the Association. The Association, if successful, shall also be entitled to recoup the costs and attorneys' fees incurred in defending any claim, counterclaim or other matter. All costs and attorneys' fees that the Association is entitled to recover or recoup from any Co-owner or their licensees or invitees under this Section may be assessed to the Co-owner and against the Co-owner's Unit, secured by the lien on the Co-owner's Unit, and collected in the manner provided in Article II of these Bylaws.

Section 2. Association's Right to Abate. The violation of the Condominium Documents shall give the Association or its authorized agents the right, in addition to the rights set forth above, to enter

upon the Common Elements or into any Unit where reasonably necessary, and summarily remove and abate, at the expense of the Co-owner in violation, any structure, thing or condition existing or maintained contrary to the Condominium Documents. The Association has no liability to any Co-owner arising out of its exercise of its removal and abatement power.

Section 3. Assessment of Fines. The violation of any provision of the Condominium Documents by any Co-owner or their licensees or invitees shall be grounds for assessment by the Association, acting through its Board of Directors, of monetary fines for the violation in accordance with Article XVI of these Bylaws.

Section 4. Failure to Enforce Rights. The failure of the Association or of any Co-owner to enforce any right, provision, covenant or condition that may be granted by the Condominium Documents shall not constitute a waiver of the right of the Association or of any Co-owner to enforce the right, provisions, covenant or condition in the future.

Section 5. Cumulative Rights. All rights, remedies and privileges granted to the Association or any Co-owner or Co-owners pursuant to any terms, provisions, covenants or conditions of the Condominium Documents shall be deemed to be cumulative and the exercise of any one or more shall not be deemed to constitute an election of remedies, nor shall it preclude the party thus exercising the same from exercising other and additional rights, remedies or privileges as may be available to the party at law or in equity.

Section 6. Rights of Co-owners. A Co-owner may maintain an action against the Association to compel enforcement of the Condominium Documents and may maintain an action for injunctive relief or damages against any other Co-owner for noncompliance with the Condominium Documents. Even if successful, Co-owners may not recover attorneys' fees from the Association, but may recover fees as may be ordered by a court from another Co-owner if successful in obtaining compliance with the Condominium Documents.

ARTICLE XVI FINES

Section 1. General. The violation by any Co-owner, occupant or guest of any provision of the Condominium Documents including any adopted rules and regulations shall be grounds for assessment by the Association, acting through its Board of Directors, of monetary fines against the involved Co-owner. The Co-owner shall be deemed responsible for the violation whether it occurs as a result of their personal actions or the actions of their family, guests, tenants or any other person admitted through the Co-owner to the Condominium.

Section 2. Procedures. Prior to imposing any fine, the Board will adhere to the following procedures:

A. Notice. Notice of the violation, including the Condominium Document provision violated, together with a description of the factual nature of the alleged offense set forth with reasonable specificity as will place the Co-owner on notice as to the violation, shall be sent by first class mail, postage prepaid, electronic transmission, or personally delivered to the representative of the Co-owner

at the address as shown in the notice required to be filed with the Association pursuant to Article VIII, Section 2C of these Bylaws.

B. Hearing and Decision. The offending Co-owner shall be provided a scheduled hearing before the Board at which the Co-owner may offer evidence in defense of the alleged violation. Except as the Board otherwise determines, the hearing before the Board shall be at its next scheduled meeting, but in no event shall the Co-owner be required to appear less than 7 days from the date of the notice. Upon appearance by the Co-owner before the Board and presentation of evidence of defense, or if the Co-owner fails to appear at the scheduled hearing, the Board shall, by majority vote of a quorum of the Board, decide whether a violation has occurred. The Board's decision is final.

Section 3. Fines. Upon violation of the Condominium Documents and upon the decision of the Board as recited above, the following fines may be levied:

FIRST VIOLATION	No fine will be levied unless the Board determines the nature of the violation is such as to be best deterred if a fine is imposed for a first violation
SECOND VIOLATION	\$25.00 Fine
THIRD VIOLATION	\$50.00 Fine
FOURTH VIOLATION AND ALL SUBSEQUENT VIOLATIONS	\$100.00 Fine

The Board of Directors may make changes in fine amounts or adopt alternative fines pursuant to Article VI, Section 11 of these Bylaws and without the necessity of amending these Bylaws. For purposes of this Section, the number of the violation (i.e., first, second etc.) is determined with respect to the number of times that a Co-owner violates the same provision of the Condominium Documents, as long as that Co-owner may be an owner of a Unit or occupant of the Condominium and is not based upon time or violations of entirely different provisions. In the case of continuing violations, a new violation will be deemed to occur each successive week during which a violation continues or in intervals as may be set forth in the Association's rules and regulations; however, no hearings other than the first hearing shall be required for successive violations if a violation has been found to exist. Nothing in this Article shall be construed as to prevent the Association from pursuing any other remedy under the Condominium Documents or the Condominium Act for the violations, or from combining a fine with any other remedy or requirement to redress any violation.

Section 4. Collection of Fines. The fines levied pursuant to this Article shall be (a) assessed to the Co-owner and against the Co-owner's Unit, (b) secured by the lien on the Co-owner's Unit, (c) immediately be due and payable, and (d) collected in the manner provided in Article II and Article XV of these Bylaws.

ARTICLE XVII
SEVERABILITY

If any term, provision, or covenant of these Bylaws or the Condominium Documents is held to be partially or wholly invalid or unenforceable for any reason, the holding shall not affect, alter, modify or impair in any manner any other term, provision or covenant of any documents or the remaining portion of any term, provision or covenant that is held to be partially invalid or unenforceable.

**CONDOMINIUM SUBDIVISION PLAN
HIDDEN HARBOR CONDOMINIUM**

OAKLAND COUNTY CONDOMINIUM
 SUBDIVISION PLAN NO. 491
 EXHIBIT B TO THE MASTER DEED OF
 HIDDEN HARBOR CONDOMINIUM
 WATERFORD TOWNSHIP, OAKLAND COUNTY, MICHIGAN

ATTENTION* COUNTY REGISTRAR OF DEEDS
 THE CONDOMINIUM SUBDIVISION PLAN NUMBER MUST
 BE CORRECTLY RECORDED IN THE COUNTY REGISTER
 NUMBER HAS BEEN ASSIGNED TO THIS PROJECT. IT
 MUST BE PROPERLY SHOWN IN THE TITLE ON THIS
 SHEET AND IN THE SURVEYOR'S CERTIFICATE ON
 SHEET TWO.

SURVEYOR
 BASNEY & SMITH, INC.
 15126 BEECH DALY
 REDFORD, MICHIGAN
 48239

DEVELOPER
 EAGLE VENTURE DEVELOPMENT CORPORATION
 4050 WEST MAPLE ROAD
 SUITE 103 BIRMINGHAM, MICHIGAN
 48010

INDEX

	TITLE	PAGE
1	SURVEY PLAN	
2	SITE PLAN	
3	FIRST FLOOR PLAN BUILDING NO. 1	
4	SECOND FLOOR PLAN BUILDING NO. 1	
5	FIRST FLOOR PLAN BUILDING NO. 2	
6	SECOND FLOOR PLAN BUILDING NO. 2	
7	SECTION PLAN BUILDINGS 1 & 2	
8		

LEGAL DESCRIPTION
 PART OF THE SOUTHWEST 1/4 OF SECTION 3 AND PART OF THE
 SOUTHEAST 1/4 OF SECTION 4, T. 3 N., R. 9 E., WATERFORD
 TOWNSHIP, OAKLAND COUNTY, MICHIGAN, DESCRIBED AS COMMENCING
 AT THE MOST EASTERLY CORNER OF EAGLE LAKE HEIGHTS SUBDIVISION
 (L. 49, P. 44, O.C.R.), THENCE NORTH 48 DEGREES 10 MINUTES 20
 SECONDS WEST ALONG THE NORTHEASTERLY LINE OF SAID SUBDIVISION
 148.50 FEET TO THE POINT OF BEGINNING, THENCE NORTH 48 DEGREES 10
 MINUTES 20 SECONDS WEST ALONG SAID SUBDIVISION LINE 394.30
 FEET TO THE EAST-WEST 1/4 CORNER OF SAID SECTIONS 3 & 4, THENCE
 SOUTH 89 DEGREES 02 MINUTES 27 SECONDS WEST 824.79 FEET,
 THENCE SOUTH 02 DEGREES 28 MINUTES 27 SECONDS
 WEST 189.12 FEET, THENCE SOUTH 66 DEGREES 50 MINUTES
 38 SECONDS WEST 238.82 FEET, THENCE NORTH 89 DEGREES
 01 MINUTES 40 SECONDS WEST 193.15 FEET, THENCE NORTH
 61 DEGREES 25 MINUTES 00 SECONDS WEST 75.90 FEET, THENCE
 NORTH 70 DEGREES 11 MINUTES 00 SECONDS WEST 46.40 FEET
 TO THE POINT OF BEGINNING, CONTAINING 4.167 ACRES MORE
 OR LESS, SUBJECT TO EASEMENTS OF RECORD.

HIDDEN HARBOR CONDOMINIUM
 TITLE PAGE

BASNEY & SMITH, INC. 15126 BEECH DALY REDFORD, MICHIGAN 48239 SURVEYOR	
DATE	DATE
FILED	FILED
RECORDED	INDEXED
SCALE	SHEET
1:100	1

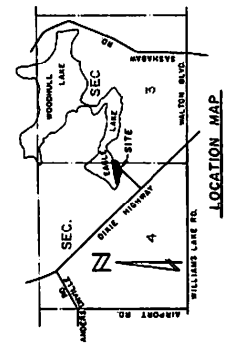
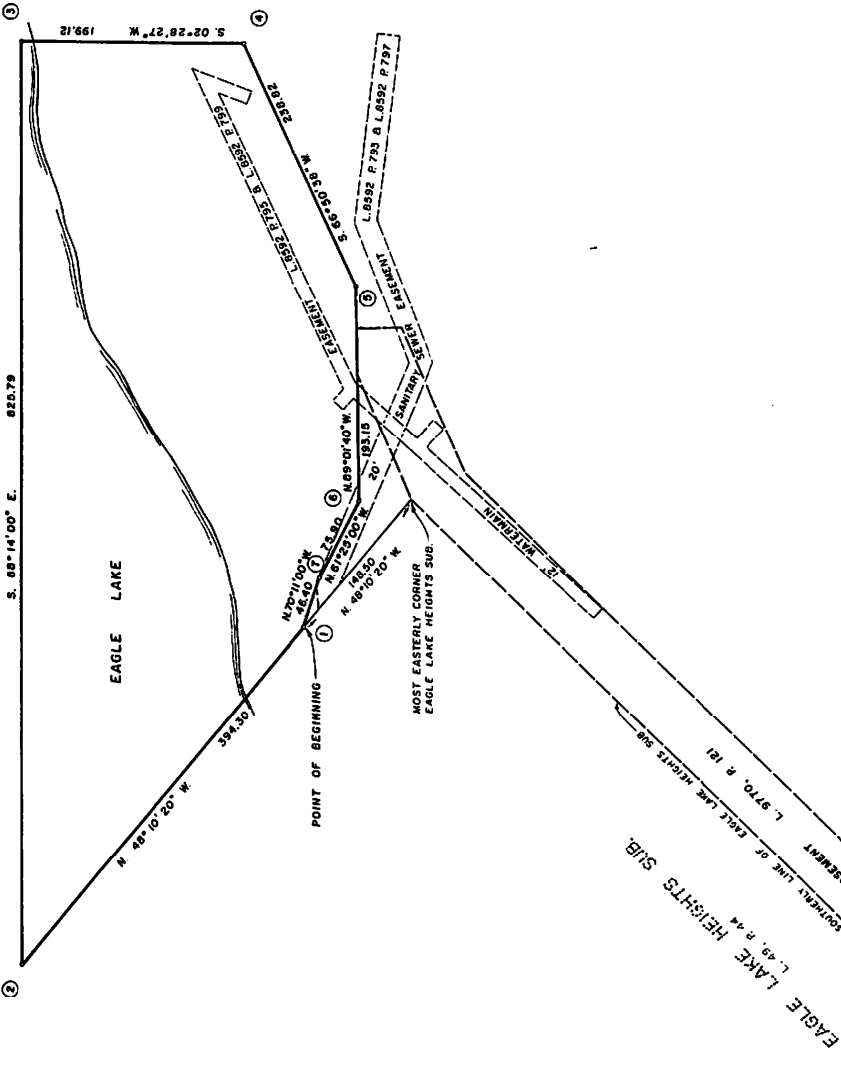

COORDINATES	NORTH	EAST
1	5099.03	4885.34
2	5361.99	4595.53
3	5336.56	5420.94
4	5137.63	5412.35
5	5043.71	5192.77
6	4946.59	4895.65
7	5063.30	4933.00

SURVEYOR'S CERTIFICATE
 I, WILLIAM L. ROSKELLY, REGISTERED LAND SURVEYOR OF THE STATE OF MICHIGAN, HEREBY CERTIFY THAT THE SUBDIVISION PLAN KNOWN AS HIDDEN HARBOR CONDOMINIUM SUBDIVISION PLAN IS SHOWN ON THE ACCOMPANYING DRAWINGS, THESE ARE NO EXISTING ENCROACHMENTS UPON THE LANDS AND PROPERTY HERE DESCRIBED THAT THE REQUIRED MONUMENTS AND IRON MARKERS HAVE BEEN LOCATED IN THE GROUND AS REQUIRED BY RULES PROMULGATED UNDER SECTION 142 OF THE PUBLIC ACTS OF 1978, THAT THE MONUMENTS AND IRON MARKERS ARE PROMULGATED UNDER SECTION 142 OF ACT NUMBER 99 OF PUBLIC ACTS OF 1978.

DATE: Nov. 3, 1987
 WILLIAM L. ROSKELLY
 REGISTERED LAND SURVEYOR
 No. 10705
 BASNEY & SMITH, INC.
 13226 BEECH DAILY ROAD
 REDFORD, MICHIGAN 48239

**HIDDEN HARBOR CONDOMINIUM
 SURVEY PLAN**

BASNEY & SMITH, INC. REGISTERED LAND SURVEYORS 13226 BEECH DAILY ROAD REDFORD, MICHIGAN 48239	
DATE	NOV 3 1987
PROJECT	HIDDEN HARBOR CONDOMINIUM
SCALE	1" = 50'
SHEET	2

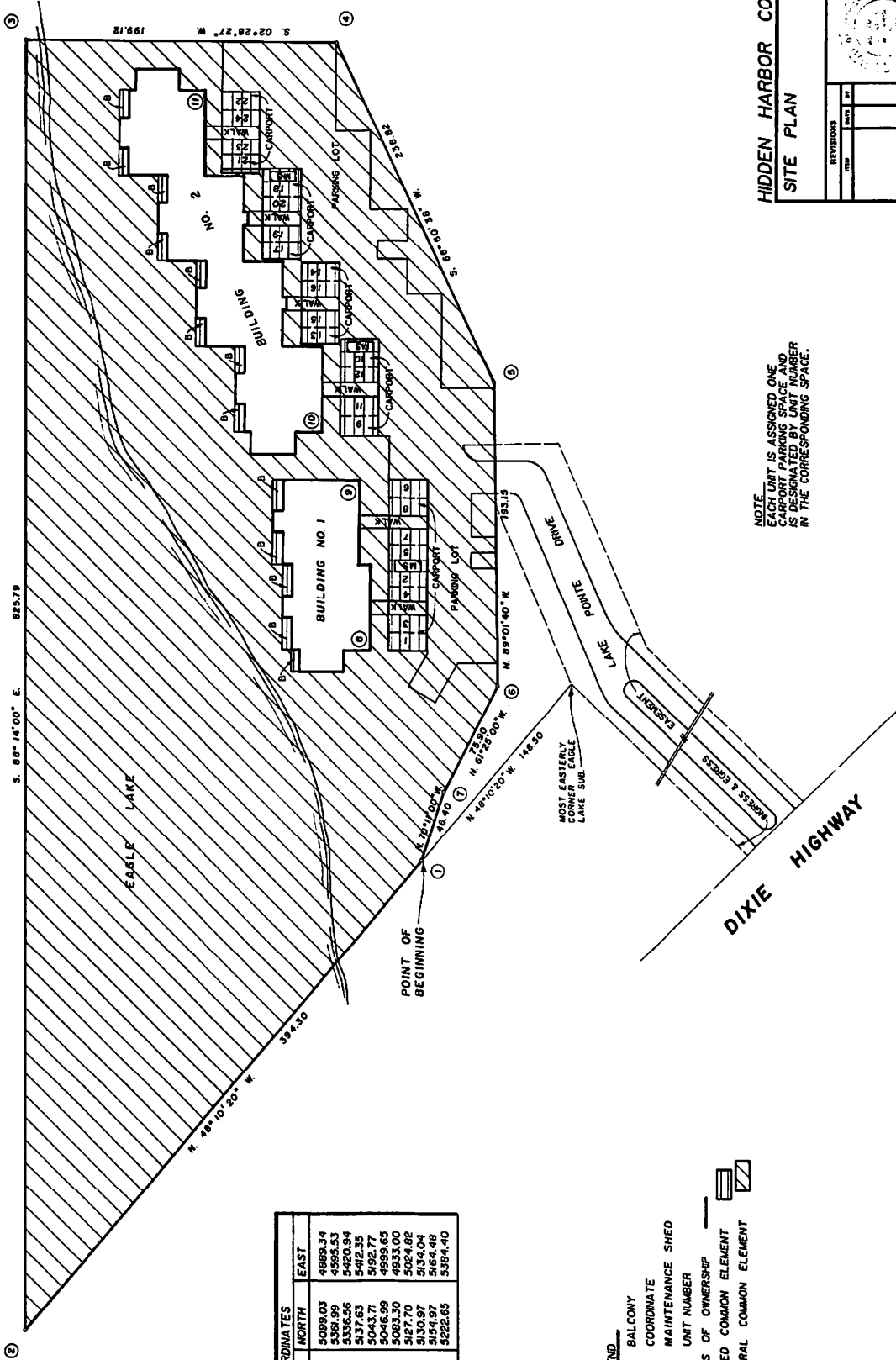
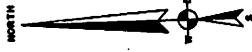

COORDINATES	NORTH	EAST
1	5099.03	4868.34
2	5361.99	4595.53
3	5336.56	5420.94
4	5137.63	5412.35
5	5043.71	5192.77
6	5046.99	4959.65
7	5171.70	4924.82
8	5137.70	5134.04
9	5130.97	5164.48
10	5154.97	5164.48
11	5222.65	5384.40

- LEGEND**
- B BALCONY
 - ⊙ COORDINATE
 - MS MAINTENANCE SHED
 - O UNIT NUMBER
 - LIMITS OF OWNERSHIP
 - LIMITED COMMON ELEMENT
 - GENERAL COMMON ELEMENT

**HIDDEN HARBOR CONDOMINIUM
SITE PLAN**

REVISIONS

NO.	DATE	BY	DESCRIPTION

BASNEY & SMITH, INC.
 ARCHITECTS
 1100 W. 10TH AVENUE, SUITE 100
 DENVER, COLORADO 80202
 PHONE: 333-1111
 FAX: 333-1110

DRAWN: J.C.B. DATE: 3-14-87
 CHECKED: [Signature] DATE: 3-11-87
 SCALE: 1" = 30'

HEET 3 OF 3

NOTE
 EACH UNIT IS ASSIGNED ONE
 CARPORT PARKING SPACE AND
 IS DESIGNATED BY UNIT NUMBER
 IN THE CORRESPONDING SPACE.

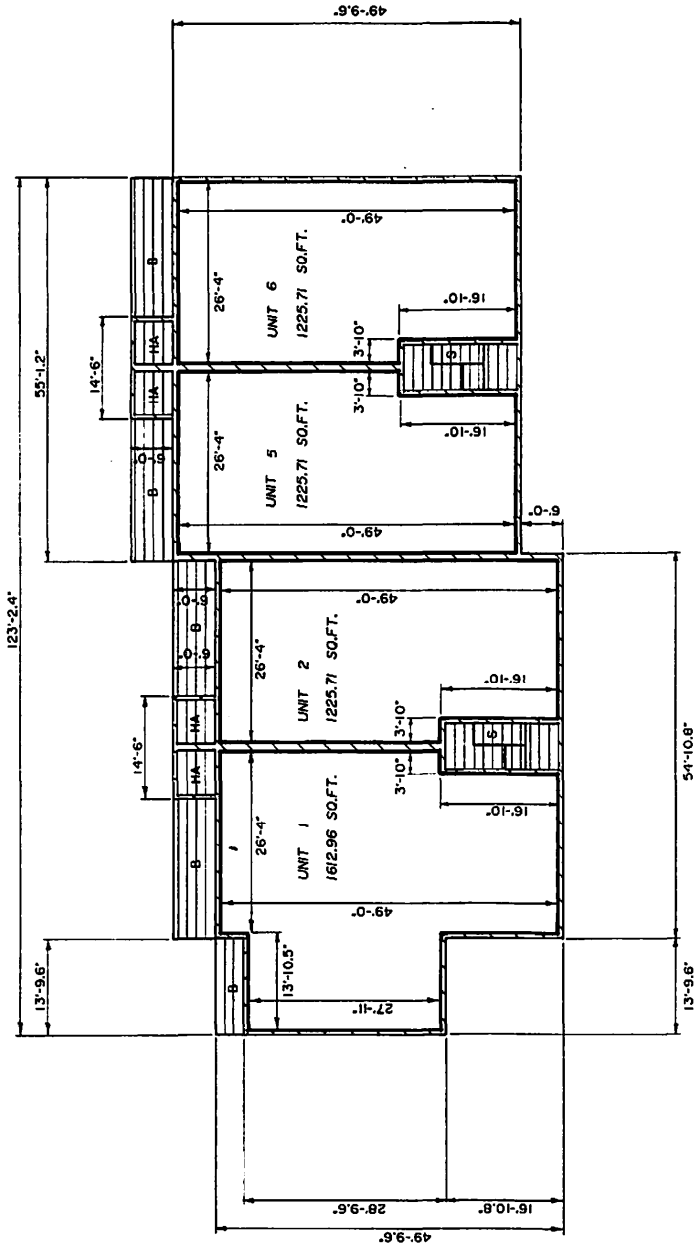

BUILDING NO. 1
FIRST FLOOR PLAN

- LEGEND**
- B BALCONY
 - HA HEATING & AIR CONDITIONING
 - S STAIRS
 - LIMITS OF OWNERSHIP
 - LIMITED COMMON ELEMENT
 - GENERAL COMMON ELEMENT

HIDDEN HARBOR CONDOMINIUM
FIRST FLOOR PLAN
BUILDING NO. 1

NO.	DATE	BY

BASNEY & SMITH, INC. REGISTERED ARCHITECTS 1000 WEST 10TH AVENUE DENVER, CO 80202	
OWNER	DATE
DESIGNED BY	DATE
CHECKED BY	DATE
SCALE	SHEET
1/8" = 1'-0"	4

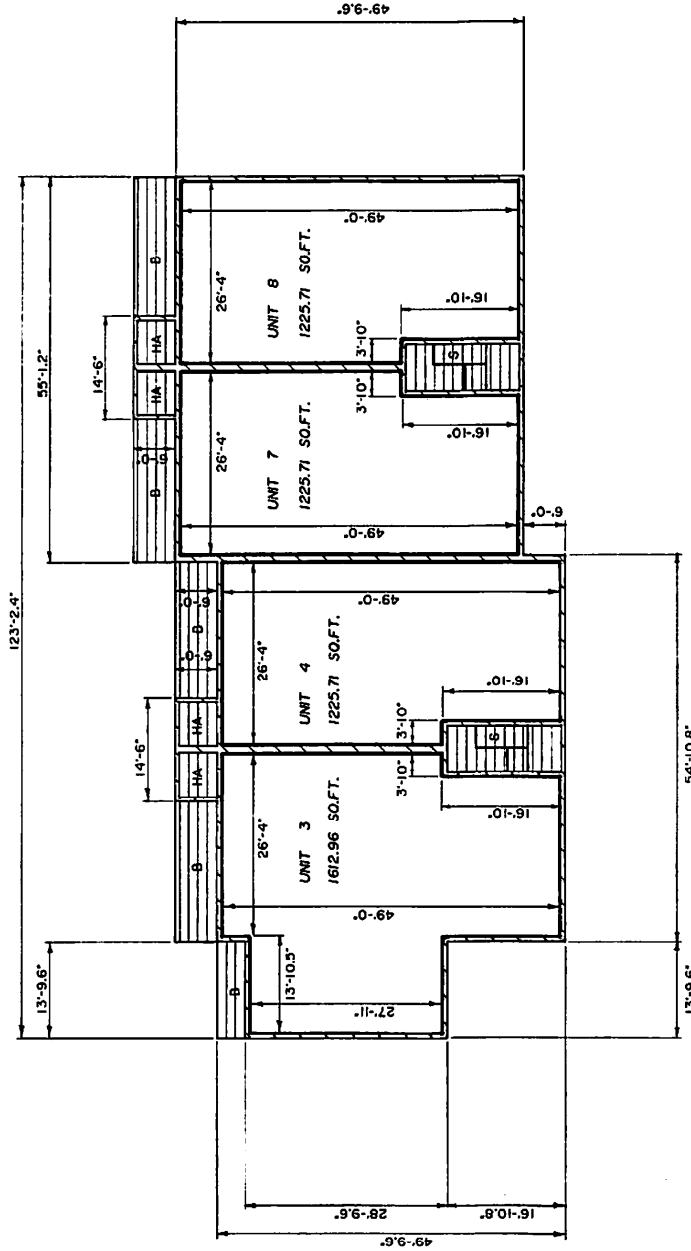

BUILDING NO. 1
SECOND FLOOR PLAN

- LEGEND**
- B BALCONY
 - HA HEATING & AIR CONDITIONER
 - S STAIRS
 - LIMITS OF OWNERSHIP
 - LIMITED COMMON ELEMENT
 - GENERAL COMMON ELEMENT

HIDDEN HARBOR CONDOMINIUM
SECOND FLOOR PLAN
BUILDING NO. 1

REVISIONS		DATE	BY

DRAWN: JCL		DATE: 11.15.87
CHECKED: [Signature]		JOB NO: 87-11-50
SCALE: 1/8" = 1'		SHEET: 5

BUILDING NO. 2
FIRST FLOOR PLAN

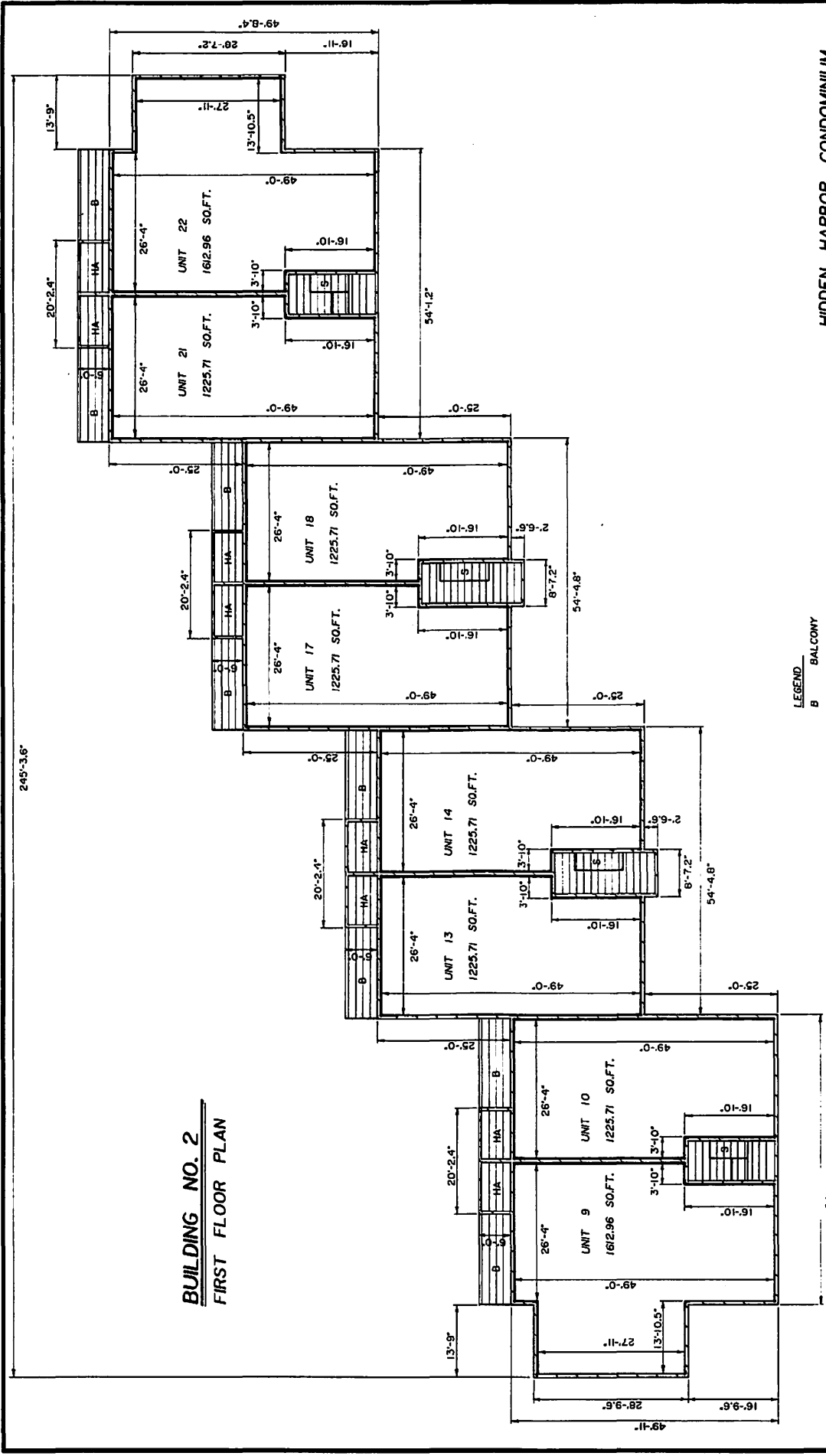

- LEGEND**
- B BALCONY
 - HA HEATING & AIR CONDITIONER
 - S STAIRS
 - LIMITS OF OWNERSHIP
 - LIMITED COMMON ELEMENT
 - GENERAL COMMON ELEMENT

HIDDEN HARBOR CONDOMINIUM
FIRST FLOOR PLAN
BUILDING NO. 2

DESIGNED BY	DATE
CHECKED BY	DATE
SCALE	1/8" = 1'
SHEET 6	

BUILDING NO. 2
SECOND FLOOR PLAN

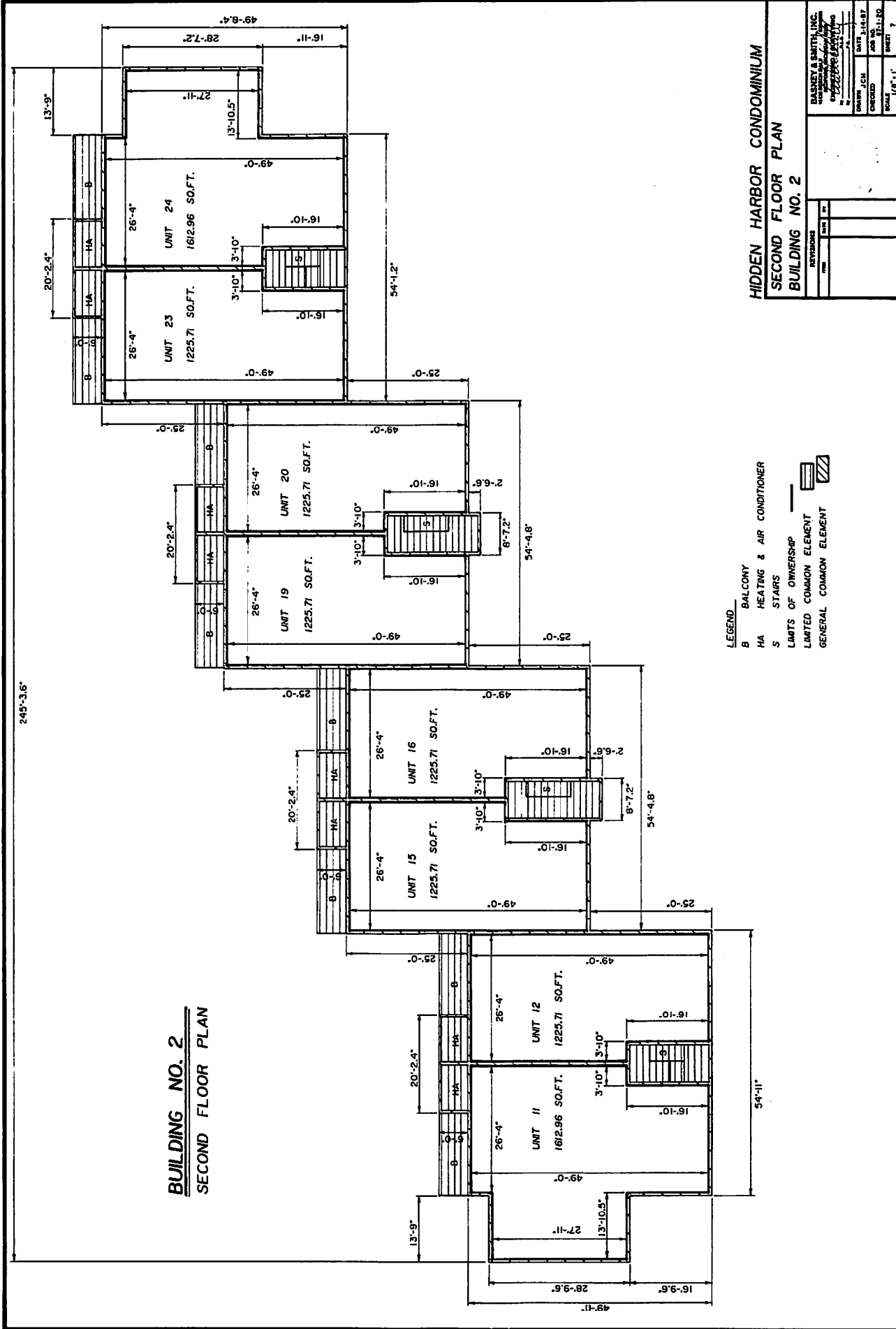

- LEGEND**
- B BALCONY
 - HA HEATING & AIR CONDITIONER
 - S STAIRS
 - LIMITS OF OWNERSHIP
 - LIMITED COMMON ELEMENT
 - GENERAL COMMON ELEMENT

HIDDEN HARBOR CONDOMINIUM
SECOND FLOOR PLAN
BUILDING NO. 2

REV.	DATE	BY	CHK.

DESIGNED BY	BARNEY & SMITH, INC.
CHECKED BY	JCL
DATE	3-14-87
JOB NO.	11-20
SCALE	1/8" = 1'
SHEET	2

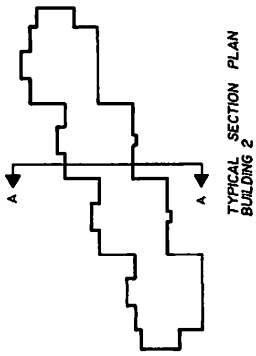

TYPICAL SECTION PLAN
BUILDING 2

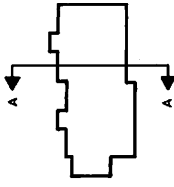

TYPICAL SECTION PLAN
BUILDING 1

LEGEND
 OWNERSHIP
 LIMITED COMMON ELEMENT
 GENERAL COMMON ELEMENT

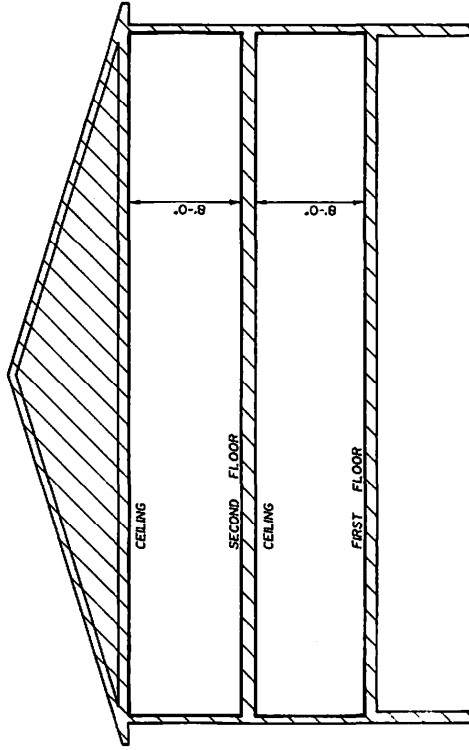

SECTION A-A
BUILDINGS 1 & 2

HIDDEN HARBOR CONDOMINIUM

SECTION PLAN
BUILDINGS 1&2

REVISIONS		DATE	
NO.	DATE	BY	CHKD.

BASNEY & SMITH, INC. REGISTERED PROFESSIONAL ENGINEERS 1100 WEST 10TH AVENUE DENVER, COLORADO 80202	
OWNER	
DESIGNED BY	
CHECKED BY	
SCALE	1/4" = 1'-0"
SHEET	8

**ARTICLES OF INCORPORATION
HIDDEN HARBOR CONDOMINIUM
ASSOCIATION**

APR 02 1987
MICHIGAN DEPARTMENT OF COMMERCE

759-503

ARTICLES OF INCORPORATION

APR 06 1987

MICHIGAN NON-PROFIT CORPORATION

Administrator
MICHIGAN DEPARTMENT OF COMMERCE
Corporation & Securities Bureau

Pursuant to the provisions of Act 162, Public Acts of 1982, the undersigned execute the following Articles:

ARTICLE I

The name of the corporation is Harbor Condominium Association.

ARTICLE II

The purposes for which the corporation is organized are:

- (a) To manage and administer the affairs of and to maintain Harbor Condominium, (the "Condominium");
- (b) To levy and collect assessments against and from the co-owner members of the corporation and to use the proceeds thereof for the purposes of the corporation;
- (c) To carry insurance and to collect and allocate the proceeds thereof;
- (d) To rebuild improvements after casualty;
- (e) To contract for and employ persons, firms, or corporations to assist in management, operation, maintenance, and administration of the Condominium;
- (f) To make and enforce reasonable regulations concerning the use and enjoyment of the Condominium;
- (g) To own, maintain and improve, and to buy, sell, convey, assign, mortgage, or lease (as Landlord or Tenant) any real and personal property, including, but not limited to, any unit in the Condominium or any other real property, whether or not contiguous to the Condominium, for the purpose of providing benefit to the members of the corporation and in furtherance of any of the purposes of the corporation;
- (h) To borrow money and issue evidence of indebtedness in furtherance of any or all of the objects of its business; to secure the same by mortgage, pledge or other lien;
- (i) To enforce the provisions of the Master Deed and Bylaws of the Condominium and of these Articles of Incorporation and such Bylaws and Rules and Regulations of the corporation as may hereafter be adopted;
- (j) To do anything required of or permitted to its as administrator of the Condominium by the Condominium Master Deed or Bylaws or by the Michigan Condominium Act;

113



(k) In general, to enter into any kind of activity; to make and perform any contract and to exercise all powers necessary, incidental or convenient to the administration, management, maintenance, repair, replacement and operation of the Condominium and to the accomplishment of any of the purposes thereof.

ARTICLE III

The corporation is organized upon a nonstock basis.

The assets of the corporation are:

Real Property:	None
Personal Property:	None

The corporation is to be financed under the following general plan:

Assessment of Members owning units in the Condominium.

The corporation is organized on a membership basis.

ARTICLE IV

The address of the registered office is:

4050 West Maple Road
Suite 103
Birmingham, Michigan 48010

The mailing address of the registered office is the same as above.

The name of the first resident agent at the registered office is:

Robert Rubin

ARTICLE V

The names and business addresses of all the incorporators are:

Robert Rubin
4050 West Maple Road
Suite 103
Birmingham, Michigan 48010

Robert Davis
4050 West Maple Road
Suite 103
Birmingham, Michigan 48010

Ruth J. Emerling
4050 West Maple Road
Suite 103
Birmingham, Michigan 48010

The above persons comprise the corporation's first board of directors.

ARTICLE VI

The term of the corporate existence is perpetual.

ARTICLE VII

The qualifications of members, the manner of their admission to the corporation, the termination of membership, and voting by the members shall be as follows:

(a) Each co-owner (including the Developer named in the Condominium Master Deed) of a unit in the Condominium shall be a member of the corporation, and no other person or entity shall be entitled to membership.

(b) Membership in the corporation shall be established by the acquisition of fee simple to a unit in the Condominium and by recording with the Register of Deeds in the County where the Condominium is located a deed or other instrument establishing a change of record title to such unit and the furnishing of evidence of same satisfactory to the corporation (except that the Developer of the Condominium shall become a member immediately upon establishment of the Condominium), the new co-owner thereby becoming a member of the corporation, and the membership of the prior co-owner thereby being terminated. Land contract vendees of units shall be members if the land contract instrument expressly conveys the vendor's interest as a member of the corporation in which event the vendor's membership shall terminate as to the unit sold.

(c) The share of a member in the funds and assets of the corporation cannot be assigned, pledged, encumbered or transferred in any manner except as an appurtenance to the member's unit in the Condominium.

(d) Voting by members shall be in accordance with the provisions of the bylaws of this corporation.

ARTICLE VIII

These Articles of Incorporation may only be amended by unanimous consent of all members.

We, the incorporators, sign our names this 11th day of March, 1987.



ROBERT RUBIN



ROBERT DAVIS



RUTH J. EMERLING

590-979

**CERTIFICATE OF AMENDMENT TO
ARTICLES OF INCORPORATION
HIDDEN HARBOR CONDOMINIUM
ASSOCIATION**

MICHIGAN DEPARTMENT OF LICENSING AND REGULATORY AFFAIRS
FILING ENDORSEMENT

This is to Certify that the CERTIFICATE OF AMENDMENT TO THE ARTICLES OF
INCORPORATION

for

HIDDEN HARBOR CONDOMINIUM ASSOCIATION

ID Number: 800843016

received by electronic transmission on January 16, 2023 **, is hereby endorsed.**

Filed on January 19, 2023 **, by the Administrator.**

The document is effective on the date filed, unless a subsequent effective date within 90 days after received date is stated in the document.



In testimony whereof, I have hereunto set my hand and affixed the Seal of the Department, in the City of Lansing, this 19th day of January, 2023.

Linda Clegg

Linda Clegg, Director

Corporations, Securities & Commercial Licensing Bureau

LARA Corporations
Online Filing System
Department of Licensing and Regulatory Affairs

Form Revision Date 07/2016

CERTIFICATE OF AMENDMENT TO THE ARTICLES OF INCORPORATION
For use by **DOMESTIC NONPROFIT CORPORATION**

Pursuant to the provisions of Act 162, Public Acts of 1982, the undersigned corporation executes the following Certificate:

The identification number assigned by the Bureau is:

800843016

The name of the corporation is:

HIDDEN HARBOR CONDOMINIUM
ASSOCIATION

The Articles of Incorporation is hereby amended to read as follows:

Article III

The Corporation is formed upon basis.

If formed on a stock basis, the total number of shares the corporation has authority to issue is

The corporation is to be financed under the following general plan:

The Corporation is formed on a basis.

Use the space below for additional Articles or for continuation of previous Articles. Please identify any Article being continued or added.

ARTICLE VIII IS DELETED IN ITS ENTIRETY AND NEW ARTICLES VIII, IX, X, XI AND XII ARE ADDED AS FOLLOWS:

ARTICLE VIII
AMENDMENTS

THESE ARTICLES MAY BE AMENDED BY THE AFFIRMATIVE VOTE OF A MAJORITY OF ALL OF THE MEMBERS OF THE CORPORATION ENTITLED TO VOTE.

ARTICLE IX
CLAIMS AGAINST DIRECTORS AND VOLUNTEER OFFICERS; ASSUMPTION OF VOLUNTEER LIABILITY BY THE CORPORATION

1. CLAIMS AGAINST DIRECTORS AND VOLUNTEER OFFICERS. UNDER ALL CIRCUMSTANCES EXCEPT THOSE LISTED IMMEDIATELY BELOW, NO DIRECTOR OR VOLUNTEER OFFICER SHALL HAVE LIABILITY TO THE CORPORATION, ITS SHAREHOLDERS, OR MEMBERS FOR MONEY DAMAGES FOR ANY ACTION TAKEN OR FAILURE TO TAKE ANY ACTION AS A DIRECTOR OR VOLUNTEER OFFICER. THIS PROVISION CANNOT ELIMINATE LIABILITY FOR:

(A) THE AMOUNT OF A FINANCIAL BENEFIT RECEIVED BY A DIRECTOR OR VOLUNTEER OFFICER TO WHICH HE OR SHE IS NOT ENTITLED;

(B) INTENTIONAL INFLICTION OF HARM ON THE CORPORATION, ITS SHAREHOLDERS, OR MEMBERS;

(C) A VIOLATION OF SECTION 551;

(D) AN INTENTIONAL CRIMINAL ACT;

(E) A LIABILITY IMPOSED UNDER SECTION 497(A).

2. ASSUMPTION OF VOLUNTEER LIABILITY. THE CORPORATION SHALL ASSUME, PAY FOR, AND UNDERTAKE ALL OBLIGATIONS AND LIABILITY FOR ANY AND ALL ACTS OR OMISSIONS OF ITS VOLUNTEER DIRECTORS AND VOLUNTEER OFFICERS IF ALL OF THE FOLLOWING ARE MET:

(A) THE VOLUNTEER WAS ACTING OR REASONABLY BELIEVED HE OR SHE WAS ACTING WITHIN THE SCOPE OF HIS OR HER AUTHORITY.

(B) THE VOLUNTEER WAS ACTING IN GOOD FAITH.

(C) THE VOLUNTEER'S CONDUCT DID NOT AMOUNT TO GROSS NEGLIGENCE OR WILLFUL AND WANTON MISCONDUCT.

(D) THE VOLUNTEER'S CONDUCT WAS NOT AN INTENTIONAL TORT.

(E) THE VOLUNTEER'S CONDUCT WAS NOT A TORT ARISING OUT OF THE OWNERSHIP, MAINTENANCE, OR USE OF A MOTOR VEHICLE FOR WHICH TORT LIABILITY MAY BE IMPOSED AS PROVIDED IN SECTION 3135 OF THE INSURANCE CODE OF 1956, ACT NO. 218 OF THE PUBLIC ACTS OF 1956, BEING SECTION 500.3135 OF THE MICHIGAN COMPILED LAWS.

ARTICLE X
INDEMNIFICATION

IN ADDITION TO THE PROVISIONS OF ARTICLE IX, THE CORPORATION MAY INDEMNIFY ITS DIRECTORS, OFFICERS, VOLUNTEERS, INDIVIDUALS, OR PERSONS IN THE FOLLOWING MANNER:

1. INDIVIDUALS. THE CORPORATION SHALL INDEMNIFY EVERY DIRECTOR, OFFICER AND VOLUNTEER OF THE CORPORATION AGAINST ALL EXPENSES AND LIABILITIES, INCLUDING REASONABLE ATTORNEY FEES AND AMOUNTS PAID IN SETTLEMENT INCURRED BY OR IMPOSED UPON THE DIRECTOR, OFFICER OR VOLUNTEER IN CONNECTION WITH ANY THREATENED, PENDING OR COMPLETED ACTION, SUIT OR PROCEEDING, WHETHER CIVIL, CRIMINAL, ADMINISTRATIVE, OR INVESTIGATIVE AND WHETHER FORMAL OR INFORMAL, TO WHICH THE DIRECTOR, OFFICER OR VOLUNTEER MAY BE A PARTY OR IN WHICH THEY MAY BECOME BY REASON OF THEIR BEING OR HAVING BEEN A DIRECTOR, OFFICER OR VOLUNTEER OF THE CORPORATION, WHETHER OR NOT THEY ARE A DIRECTOR, OFFICER OR VOLUNTEER AT THE TIME SUCH EXPENSES ARE INCURRED, IF THE PERSON ACTED IN GOOD FAITH AND IN A MANNER WHICH THEY REASONABLY BELIEVED TO BE IN OR NOT OPPOSED TO THE BEST INTERESTS OF THE CORPORATION AND, WITH RESPECT TO ANY CRIMINAL ACTION OR PROCEEDING, HAD REASONABLE CAUSE TO BELIEVE THAT THEIR CONDUCT WAS LAWFUL; PROVIDED, HOWEVER, THAT NO INDEMNIFICATION SHALL BE MADE IN RESPECT TO ANY CLAIM, ISSUE, OR MATTER AS TO WHICH SUCH PERSON SHALL HAVE BEEN FINALLY ADJUDGED TO BE LIABLE FOR GROSS NEGLIGENCE OR WILLFUL MISCONDUCT IN THE PERFORMANCE OF HIS DUTY TO THE CORPORATION UNLESS AND ONLY TO THE EXTENT THAT A COURT SHALL DETERMINE UPON APPLICATION THAT, DESPITE THE ADJUDICATION OF LIABILITY BUT IN VIEW OF ALL THE CIRCUMSTANCES OF THE CASE, SUCH PERSON IS FAIRLY AND REASONABLY ENTITLED TO INDEMNIFICATION FOR SUCH EXPENSES AS THE COURT SHALL DEEM PROPER.
2. EXPENSES. TO THE EXTENT THAT A DIRECTOR, OFFICER, OR VOLUNTEER HAS BEEN SUCCESSFUL ON THE MERITS OR OTHERWISE IN DEFENSE OF ANY ACTION, SUIT, OR PROCEEDING REFERRED TO IN SECTION 1, OR IN DEFENSE OF ANY CLAIM, ISSUE, OR MATTER THEREIN, AND INDEMNIFICATION IS GRANTED, THEY SHALL BE INDEMNIFIED AGAINST EXPENSES (INCLUDING ATTORNEYS' FEES) ACTUALLY AND REASONABLY INCURRED BY HIM IN CONNECTION THEREWITH AND IN ANY ACTION, SUIT OR PROCEEDING BROUGHT TO ENFORCE THE INDEMNIFICATION PROVIDED FOR HEREIN.
3. DETERMINATION OF RIGHT TO INDEMNIFICATION. EXCEPT IN A SITUATION GOVERNED BY SECTION 2, ANY INDEMNIFICATION UNDER SECTION 1 (UNLESS ORDERED BY A COURT) SHALL BE MADE BY THE CORPORATION ONLY AS AUTHORIZED IN THE SPECIFIC CASE UPON DETERMINATION THAT INDEMNIFICATION OF THE DIRECTOR, OFFICER, OR VOLUNTEER IS PROPER IN THE CIRCUMSTANCES BECAUSE THEY HAVE MET THE APPLICABLE STANDARD OF CONDUCT SET FORTH IN SECTION 1. SUCH DETERMINATION SHALL BE MADE (A) BY A MAJORITY VOTE OF DIRECTORS ACTING AT A MEETING AT WHICH A QUORUM CONSISTING OF DIRECTORS WHO WERE NOT PARTIES TO SUCH ACTION, SUIT, OR PROCEEDING IS PRESENT, OR (B) IF SUCH A QUORUM IS NOT OBTAINABLE (OR EVEN IF OBTAINABLE), AND A MAJORITY OF DISINTERESTED DIRECTORS SO DIRECTS, BY INDEPENDENT LEGAL COUNSEL (COMPENSATED BY THE CORPORATION), IN A WRITTEN OPINION, OR (C) IF SUCH A QUORUM IS NOT OBTAINABLE, THEN BY A MAJORITY VOTE OF A COMMITTEE OF DIRECTORS WHO ARE NOT PARTIES TO THE ACTION (SUCH COMMITTEE SHALL CONSIST OF NOT LESS THAN TWO (2) DISINTERESTED DIRECTORS), OR (D) BY THE SHAREHOLDERS OR MEMBERS.
4. ADVANCE PAYMENT OF EXPENSES. EXPENSES OF EACH PERSON INDEMNIFIED HEREUNDER INCURRED IN DEFENDING A CIVIL, CRIMINAL, ADMINISTRATIVE, OR INVESTIGATIVE ACTION, SUIT, OR PROCEEDING (INCLUDING ALL APPEALS), OR THREAT THEREOF, MAY BE PAID BY THE CORPORATION IN ADVANCE OF THE FINAL DISPOSITION OF SUCH ACTION, SUIT, OR PROCEEDING AS AUTHORIZED BY THE BOARD OF DIRECTORS, WHETHER A DISINTERESTED QUORUM EXISTS OR NOT, UPON RECEIPT OF AN UNDERTAKING BY OR ON BEHALF OF THE DIRECTOR, OFFICER, OR VOLUNTEER TO REPAY SUCH AMOUNT UNLESS IT SHALL ULTIMATELY BE DETERMINED THAT HE IS ENTITLED TO BE INDEMNIFIED BY THE CORPORATION. THE UNDERTAKING SHALL BE BY UNLIMITED GENERAL OBLIGATION OF THE PERSON ON WHOSE BEHALF ADVANCES ARE MADE, BUT NEED NOT BE SECURED.
5. RIGHTS NOT EXCLUSIVE. THE INDEMNIFICATION OR ADVANCEMENT OF EXPENSES PROVIDED BY THIS ARTICLE SHALL NOT BE DEEMED EXCLUSIVE OF ANY OTHER RIGHTS TO WHICH THOSE SEEKING INDEMNIFICATION OR ADVANCEMENT OF EXPENSES MAY BE ENTITLED AS A MATTER OF LAW OR UNDER THESE ARTICLES OF INCORPORATION, THE CONDOMINIUM DOCUMENTS, OR ANY CONTRACTUAL AGREEMENT. HOWEVER, THE TOTAL AMOUNT OF EXPENSES FOR INDEMNIFICATION FROM ALL SOURCES COMBINED SHALL NOT EXCEED THE AMOUNT OF ACTUAL EXPENSES INCURRED BY THE PERSON SEEKING INDEMNIFICATION OR ADVANCEMENT OF EXPENSES. THE INDEMNIFICATION PROVIDED FOR IN THIS ARTICLE SHALL CONTINUE AS TO A PERSON WHO HAS CEASED TO BE A DIRECTOR, OFFICER, OR VOLUNTEER AND SHALL INURE TO THE BENEFIT OF THE HEIRS, EXECUTORS, AND ADMINISTRATORS OF SUCH A PERSON.
6. DIRECTORS AND OFFICERS LIABILITY INSURANCE. THE CORPORATION MAY PURCHASE AND MAINTAIN INSURANCE ON BEHALF OF ANY PERSON WHO IS OR WAS A DIRECTOR, OFFICER, OR VOLUNTEER OF THE CORPORATION, OR IS OR WAS SERVING AT THE REQUEST OF THE CORPORATION AS AN UNPAID, VOLUNTEER DIRECTOR, VOLUNTEER OFFICER, OR VOLUNTEER OF ANOTHER CORPORATION (WHETHER NONPROFIT OR FOR PROFIT), PARTNERSHIP, JOINT VENTURE, TRUST, OR OTHER ENTERPRISE AGAINST ANY LIABILITY ASSERTED AGAINST HIM AND INCURRED BY HIM IN ANY SUCH CAPACITY OR ARISING OUT OF HIS STATUS AS SUCH, WHETHER OR NOT THE CORPORATION WOULD HAVE THE POWER TO INDEMNIFY HIM AGAINST SUCH LIABILITY UNDER THE PROVISIONS OF THIS ARTICLE OR OF THE MICHIGAN NONPROFIT CORPORATION ACT.

TO THE EXTENT THAT ANY PROVISION OF THIS ARTICLE CONFLICTS WITH THE PROVISIONS OF ARTICLE IX, THE PROVISIONS OF ARTICLE

IX SHALL CONTROL.

ARTICLE XI
ACTION WITHOUT MEETING

ANY ACTION THAT MAY BE TAKEN AT A CORPORATION MEETING (EXCEPT FOR THE ELECTION OR REMOVAL OF DIRECTORS) MAY BE TAKEN WITHOUT A MEETING BY WRITTEN VOTE OR BALLOT OF THE MEMBERS. WRITTEN VOTES OR BALLOTS SHALL BE SOLICITED IN THE SAME MANNER AS PROVIDED IN THE CORPORATION'S BYLAWS FOR THE GIVING OF NOTICE OF CORPORATION MEETINGS. SUCH SOLICITATIONS SHALL SPECIFY: (1) THE PROPOSED ACTION; (2) THAT THE MEMBER CAN VOTE FOR OR AGAINST ANY SUCH PROPOSED ACTION; (3) THE PERCENTAGE OF APPROVALS NECESSARY TO APPROVE THE ACTION; AND (4) THE TIME BY WHICH WRITTEN VOTES MUST BE RECEIVED TO BE COUNTED. APPROVAL BY WRITTEN VOTE OR BALLOT SHALL BE CONSTITUTED BY RECEIPT, WITHIN THE TIME SPECIFIED IN THE WRITTEN VOTE OR BALLOT, OF A NUMBER OF APPROVALS THAT EQUALS OR EXCEEDS THE NUMBER OF VOTES THAT WOULD BE REQUIRED FOR APPROVAL IF THE ACTION WERE TAKEN AT A MEETING. ONLY THE BOARD OF DIRECTORS MAY INITIATE AN ACTION UNDER THIS SECTION.

ARTICLE XII
REMOVAL OF DIRECTORS

AT ANY ANNUAL OR SPECIAL MEETING OF THE CORPORATION DULY CALLED AND HELD, ANY ONE OR MORE OF THE DIRECTORS MAY BE REMOVED WITH OR WITHOUT CAUSE BY THE AFFIRMATIVE VOTE OF MORE THAN 50% OF ALL MEMBERS AND A SUCCESSOR MAY THEN AND THERE BE ELECTED TO FILL ANY VACANCY CREATED. THE QUORUM REQUIRED TO ELECT ANY SUCCESSOR OF A REMOVED DIRECTOR SHALL BE THE NORMAL QUORUM REQUIREMENT SET FORTH IN THE BYLAWS. ANY DIRECTOR WHOSE REMOVAL HAD BEEN PROPOSED SHALL BE GIVEN AN OPPORTUNITY TO BE HEARD AT THE MEETING.

2. The foregoing amendment to the Articles of Incorporation was duly adopted on: 09/30/2022 by the

members or shareholders at a meeting in accordance with Section 611(3) of the Act.

This document must be signed by an authorized officer or agent:

Signed this 16th Day of January, 2023 by:

Signature	Title	Title if "Other" was selected
Evan M. Alexander	Authorized Agent	

By selecting ACCEPT, I hereby acknowledge that this electronic document is being signed in accordance with the Act. I further certify that to the best of my knowledge the information provided is true, accurate, and in compliance with the Act.

Decline Accept