



AXLE Operation & Service MANUAL

A  Company

Table of Contents

Safety Notice	3
New Axle Setup	4
Maintenance Schedule	4
Axle Identification	5
Loading And Application	6-7
Trailer Electrical	8-9
2,000 lb - 8,000 lb	10-17
Brakes	10
Electrical	11
Hubs, Drums and Bearings	12
Posi-Lube Lubrication Procedure	13
Suspension Systems	13
Suspensions Torque Requirements	14
Wheel and Tire Safety	15
Replacement Parts	16
Troubleshooting Guide Brakes	17
10,000 lb - 16,000 lb	18-30
Electric Brakes	18-19
Disc Brakes	19-20
Hubs & Drums	20
Bearings	21-22
Lubrication	22
Suspension	23
Equalizer Replacement	24
Wheels & Tires	24
Torque Requirements	24
Storage and Infrequent Use	25
Parts Lists	26-27
Troubleshooting	28-30
Warranty	31
Sales & Service	32

Safety Notice

Providing safe dependable operation of your axle(s) and related components is important. This manual provides basic procedures for service and repair using established industry standards and techniques. There are many variations in procedures to repair and maintain your axle(s) and its related parts; however, it is not possible to provide you with all the details for various service procedures. Refer to your trailer manufacturers' owners manual for any specific warnings and procedures that may relate to the safety and maintenance of your trailer. If these procedures are not clear to you or if you are unsure of how to proceed you should contact a trailer repair facility who has a trained axle repair technician for advice or repair.



**THIS SYMBOL WARNS OF
POSSIBLE PERSONAL INJURY**

New Axle Setup

Lug Nut Torque	Re-torque lug nuts on new trailers at 2.5, 50 miles. See pages 20 and 21 for torque requirements and techniques.
Brake Adjustment	All 8K, 10K, 12K, and 16K brakes are self adjusting. the brakes will automatically adjust as needed regardless of direction of travel.
Tire Pressure	See tire manufacturer's recommendations.
Brake Synchronization	Refer to Brake Controller manufacturer's recommendations.

Maintenance Schedule

Lug nuts should be checked periodically after initial setup period.

Before Each Use

- Test that brakes are functional
- Check battery charge and switch operation of breakaway systems.
- Check that tire inflation meets tire manufacturers recommendations..

3 Months or 3,000 Miles

- Wheels should be checked for cracks, dents, or other distortions.

6 Months or 6,000 Miles

- Brake magnets should be checked for wear and current draw.
- Brake controller should be checked for correct modulation and amperage.
- Suspension parts such as the springs, equalizers, hangers, and fasteners should be checked for bending, loosening, and excessive wear.

12 Months or 12,000 Miles

- Brake linings should be checked for wear and contamination.
- Brake cylinders (hydraulic) should be checked for fluid leaks or sticking.
- Brake lines (hydraulic) should be checked for cracks, leaks, or kinks.
- Wiring should be checked for bare spots, fraying, etc.
- Drums should be checked for abnormal scoring and excessive wear.
- Wheel bearings and races should be checked for corrosion and wear.
- Seals should be checked for leakage.
- Springs should be checked for wear and loss of arch.
- Welds should be inspected on hangers.

Axle Identification

Rockwell American offers many different combinations and capacities of axles. In order to identify your axles you will need to locate the axle identification label on your axle beam. The labels will appear similar to the one below.

Standard Label



The standard axle label can be found on most axle assemblies and beams. With this information your axle can easily be identified by any of our distribution locations or technical support. Basic specifications can be determined by the three line short description.

Serial Label

In addition to a standard label, DOT requires that all axles rated at 10,000 lbs and above have a serialized identification label on them. Below are two styles of serial labels.

The newer style is a 3x2 adhesive tag.

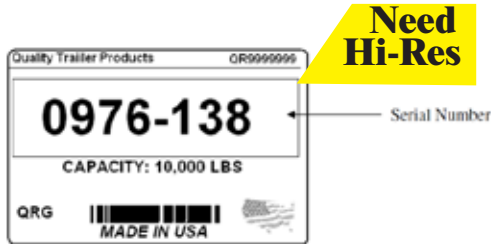

The second, older style is a 3x1 metal plate that is riveted onto the axle.



Serial number information will be required for all warranties.

Loading and Application

GAWR vs. GVWR

An easy way to determine the carrying capacity of your axles is to locate the Vehicle Identification. Number tag on your trailer. It would appear similar to the one below.



Often the VIN tag will list each axle's rated capacity separate. The capacity will be listed as the GAWR (Gross Axle Weight Rating). The total capacity of the trailer will be listed as the Gross Vehicle Weight Rating (GVWR). Often this will include the "tongue weight" and therefore cannot be relied upon to determine the axle capacity.

Levelness & Distribution

It is important when towing the trailer that several factors are taken into account. The first is the levelness of the trailer. The trailer should be level to the ground. If the hitch is too high or too low one axle will be given more of the load and the overall center of gravity will be changed. Failure to properly level the trailer can result in anything from poor braking performance, pre-mature tire wear, to decreased bearing life.

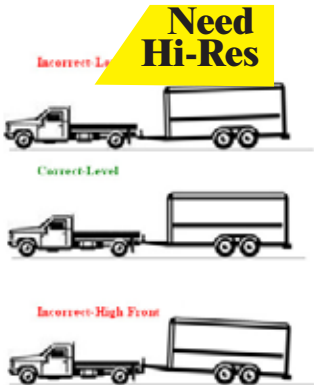

The distribution of the load on the trailer is also a factor. If one axle carries a load higher than its rated GAWR, that axle will be more likely to suffer from tire wear and bearing problems. It cannot be assumed that if the load is less than the GVWR that an axle will not be overloaded.

Note:

When loading the trailer it is important that the weight being placed on the axle does not exceed that axle's rated capacity. This is important on rear loading trailers where the back axle may briefly carry the entire load.

Example:

A tandem trailer with two 10,000 lb rated axles being loaded with a 12,000 lb piece of machinery may exceed the rating of the rear axle.

Torsion axles

Torsion axles have independent suspensions. The loading of the trailer as well as the road conditions can be factors in the lifespan of the axle and its components. Severely uneven terrain such as those found in mining, oil fields, and exploration sites can cause severe shock loads and overload situations capable of bending the axle's spindle, and causing bearing failure. It is important for the life of the axle that the load be evenly distributed and that all tires maintain contact with the ground while the trailer is loaded.

Weigh in

The best way to verify that a given load is properly distributed as well as ensure that the GAWR has not been exceeded is to weigh the trailer at a truck scale. Position 1, below, shows how to determine the combined axle load.

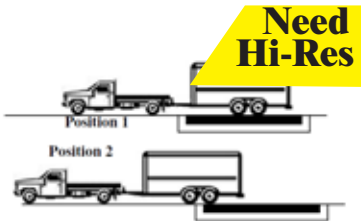

This Position 2 shows how to determine the load on each axle. The rear axle's load will be provided on the weigh slip for Position 2. The front axle's can be determined by subtracting the combined load from the rear axle load.

Front Axle = Axle Weight (Position 1) – Axle Weight (Position 2)

Rear Axle = Axle Weight (Position 2)

This method can be slightly modified to determine the distribution and weight on triple axle assemblies. As shown below.

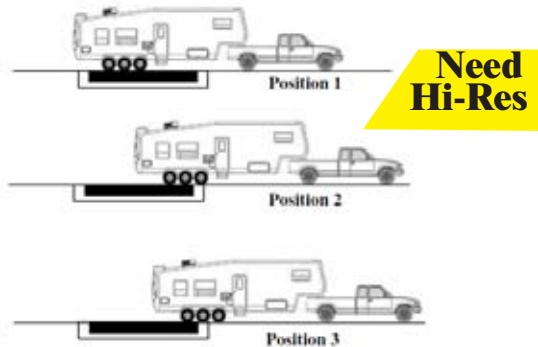

Front Axle = Axle Weight (Position 1) – Axle Weight (Position 2)

Mid Axle = Axle Weight (Position 2) – Axle Weight (Position 3)

Rear Axle = Axle Weight (Position 3)

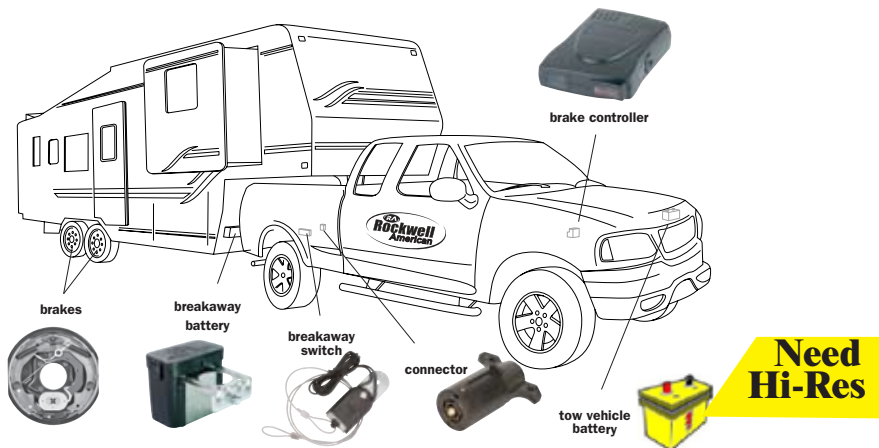

If equipped with electric brakes, the diagrams below will be helpful in determining the type of connector installed on the trailer as well as a schematic of the pin connections. Detailed schematic is shown on page 9.

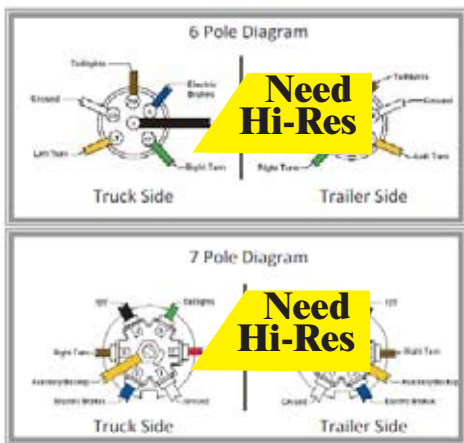

These diagrams represent the most common configurations found on trailers with electric brakes. 4 and 5 way trailer connections are not normally used on trailers with electric brakes. These configurations do not have a dedicated brake wire. Wiring gage is also important when using a trailer with electrical brakes. Use of the improper gage of wire can result in decreased brake performance.

NUMBER OF BRAKES	WIRE LENGTH TRAILER HITCH TO AXLE	MINIMUM WIRE SIZE
2	All Lengths	12 AWG
4	Less Than 30 Feet	12 AWG
4	30 - 50 Feet	10 AWG
6	Less Than 30 Feet	10 AWG
6	30 - 50 Feet	8 AWG

Refer to Brake Controller manual provided by the installer for procedure and operation of the controller.

Need Hi-Res

Brake Synchronization

It is important to ensure that the trailer brakes are properly synchronized to the tow vehicle brakes. This is necessary for the brakes to operate as designed as well as prevent pre-mature wear of the brake components.

Wiring Schematic 7 Way

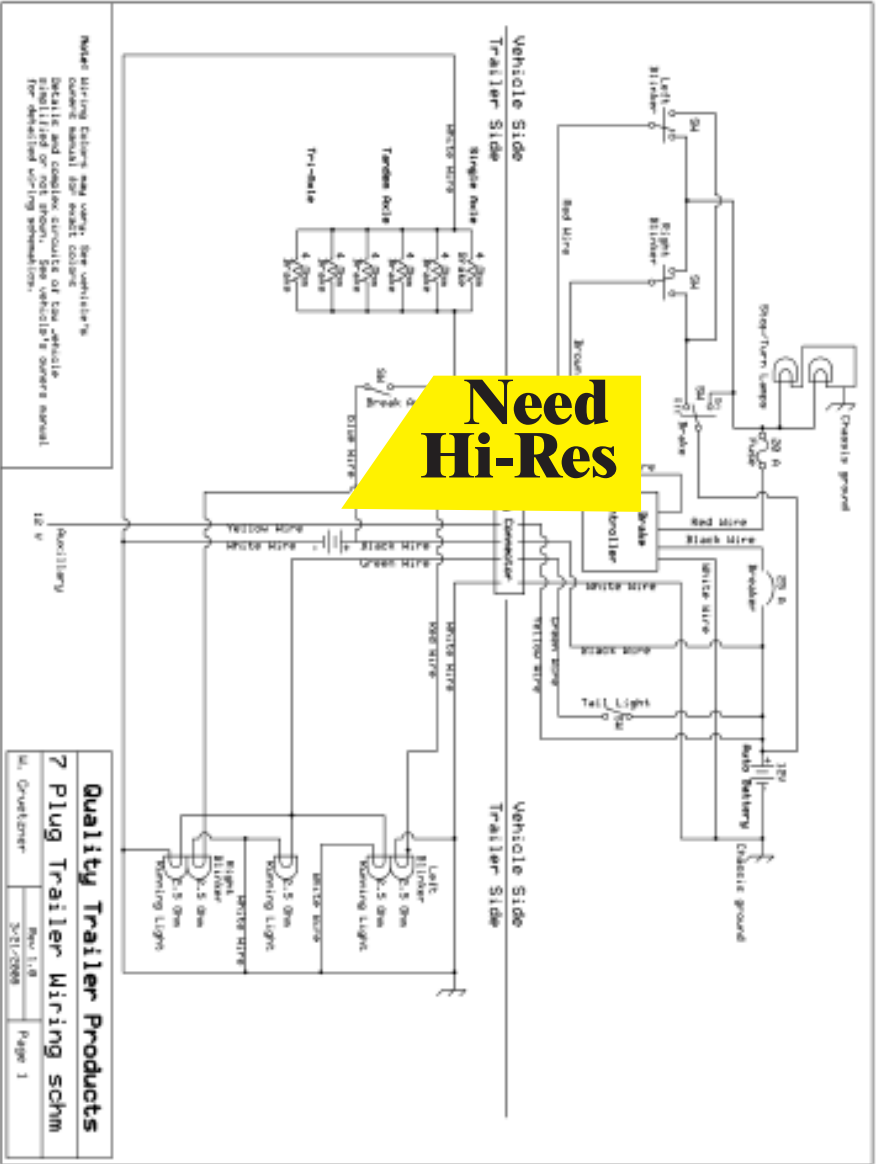

2,000 lb to 8,000 lb Axle Capacity

Brakes

Your trailers electric brakes are actuated by an electric magnet which is modified by an electrical impulse from the brake controller. The trailer brakes will apply smoothly and in sync with the truck brakes if all the brake components are installed and connected properly. The brakes are activated with the electrical impulse from the controller to the magnets which, when in contact with the armature plate, will apply the pressure to the primary shoe and will engage the shoe. As brake pressure (applied by the driver) is increased the electrical flow to the magnets increases the pressure between the brakes and drums to meet the braking requirements of the driver. Electric brakes have been used on a variety of trailers for many years and offer many benefits to the driver. Please refer to the brake controller information provided by the installer of your towing vehicle for procedure and operation of the controller.

DOUBLE CHECK!

- Make sure your controller is installed according to the mfg's recommendations.
- Make sure that the proper brake controller adjustments have been made to correctly engage the tow vehicle brakes and the trailer brakes to work together to providing safe and comfortable braking.
- Make sure that the brakes have been properly seated by applying the brakes repeatedly and lightly about 20 to 25 times at a low speed (under 25 miles per hour) to begin the "seating in" of the brake to the brake drum components. Do this in a safe and low traffic area for everyone's safety.

Below is a view of the 10" and 12" brakes used on your trailers axle(s), depending on your trailer and manufacturer's specifications.

Right Hand 10"
Electric Brake
Self Adjusting



Left Hand 12"
Electric Brake
Self Adjusting



Electric Brake Maintenance

Your trailer brakes should be adjusted between 250 to 300 miles after all of the brake components have seated. Since driving conditions and areas vary you should re-check brakes adjustments at a minimum of 3,000 miles. Self adjusting brakes will auto adjust to required condition.

Manual Adjustment Procedure

(with self adjusting brakes will auto adjust to required)

1. Make sure your trailer is on a level surface and is free of any potentially dangerous items.
2. Jack up the trailer and secure with jack stands. Make sure you are using the trailer manufacturer's procedure for jacking and safely supporting the trailer until the tire and wheel are off of the ground.
3. Find the adjusting hole cover and remove it from the backing plate.
4. Use a brake adjusting tool to adjust the star wheel (of the adjuster) and expand the brakes until the brake shoes are sufficiently expanded so that the tire and wheel will not easily rotate.
5. Now move the star wheel in the opposite direction until you can feel a little resistance from the brake and replace the hole cover.
6. Carefully lower the tire to the ground.
7. Repeat this procedure for all wheels making sure to adjust all brakes at the same time.

Electrical

Voltage Measurement Procedure

To measure voltage, connect the voltmeter to both magnet wire leads while the towing vehicle is connected and the engine is running to insure accurate readings. The voltage should begin at 0 as the controller is increased slowly to approximately 12 volts. If the controller does not produce this voltage control refer to your brake controller trouble shooting and information manual. The lower reading will provide smoother braking while the higher may produce sharp or severe braking.

Amperage Measurement Procedure

Amperage is the electrical current flowing in the brake system while the magnets are energized. Make sure of your ammeter's rating to prevent damage to the meter. An easy place to check the amperage is at the output wire from the brake controller to the brakes. Disconnect this (blue) wire and put the ammeter in series into this line. Individual amperage draw can be measured at the magnet by inserting the ammeter in the line of the magnet you wish to check. Disconnect one of the wire leads from the magnet and attach the ammeter between the two wires. Reconnect the wires when completed. Please refer to the following chart.

BRAKE SIZE	AMPS TO MAGNET	2 BRAKES	4 BRAKES	6 BRAKES
7 x 1-1/4	2.5	5.0	10.0	15.0
10 x 2-1/4	3.0	6.0	12.0	18.0
12 x 2	3.0	6.0	12.0	18.0
12 x 3-1/2	3.0	6.0	12.0	18.0

There are several possible reasons that may cause voltage variations. Listed below are the most probable.

- Poor electrical connections.
- Open circuits
- Broken wires or incorrect wire size.
- Brake controller malfunction.
- Electrical problems can also be caused by bare wires, defective controllers or shorts in the magnet coil.

Locating the source of a short circuit should be done by checking individual sections. Should you find the amperage reading drops to zero after disconnecting the trailer, then the short is in the trailer. If the amperage is high after all of the magnets are disconnected, the short is somewhere in the trailer wiring.

Please note that the majority of electrical brake complaints can be traced to the controller. Refer to your brake controller manual to insure it is correctly adjusted and that the connections are in compliance with the manufacturer's specifications.

Hubs, Drums And Bearings

Rockwell American bearing configuration uses industry standards for bearing sets (bearings & cones) and hubs. This standard of using tapered roller bearings helps to reduce the axial end play provided at assembly and is essential to performance of the bearings life. The bearings are packed with lithium base grease. Your axles may be equipped with the Rockwell American Posi-lube system which allows for lubricating the hubs at a 3/16" nipple grease fitting. This option allows grease to flow through specially machined axle spindles, which have been drilled to allow the grease to be passed from the fitting to the inner bearing and back out through the outer bearing.

Brake Drum Inspection

The brake drum surface should be inspected for scoring or excessive wear. If the wear is greater than .020" oversized it should be resurfaced. If the drum has worn out of round by more than .015" it should be re-machined.

If wear or scoring is more than .090" the hub and drum assembly will have to be replaced. The armature surface (which contacts the magnet) needs to be inspected for uneven wear or scoring. Drums can be resurfaced removing no more than .030" and should be to 120 micro inch finish. In the event you need to turn the drums or resurface the armature it is recommended that you replace the magnets at the same time.

Special notes

- Make sure the inside of the hub cavity is carefully cleaned and free of any contamination following turning and before reassembly.

Hub Inspection Removal, Replacement And Adjustments

A. Removal of Hub

1. Remove wheel and grease cap
2. Remove cotter pin
3. Unscrew the spindle nut counter clockwise
4. Remove spindle washer
5. Remove hub from spindle

B. Seal Inspection and Replacement

1. Seals should be replaced each time the hub is removed.
2. Pry the seal out of the hub with a screwdriver.
3. Tap new seal into place.

C. Bearing Maintenance, Adjustments, and Replacement

1. Inspect for corrosion and wear. If any rust or wear exists on the bearing then remove and replace.
2. If bearings are found to be in good condition, then cleaning and repacking the grease is all that is needed.

(Note: Do not spin bearings with compressed air.)

3. Hand pack each bearing individually using a premium lithium base wheel bearing grease.
4. Reinstall the hub, reversing the procedure above using the bearing adjustment procedures below.
5. If you have the Posi-Lube system refer to the "Posi-Lube Lubrication Procedure".

D. Bearing Adjustment

1. Feel and Drag Method

Tighten slotted nut until hub drags slightly when rotated. (Rotating the hub while tightening the nut seats the bearing.) Loosen the slotted nut 1/6 turn (1 hex) to align nut slot with the cotter pin hole. Wheel should turn freely. Insert new cotter pin through nut and spindle. If necessary loosen, never tighten, nut to align slot with the hole in the spindle. Bend one leg of cotter pin over the end of the spindle and the other leg over the nut. Tap legs slightly to set. Cotter pin must be tight.

2. Torque Wrench Method

Make sure nut is loose. Tighten nut with torque wrench to an initial torque of 50 ft. lbs. Loosen nut from initial torque and finger tighten. Insert new cotter pin through nut and spindle. If necessary loosen, never tighten, nut to align slot with the hole in the spindle. Bend one leg of cotter pin over the end of the spindle and the other leg over the nut. Tap legs slightly to set. Cotter pin must be tight.

Posi-Lube Lubrication Procedure

1. Remove the rubber cap at end of the grease cap.
2. Using a standard grease gun place the tip onto the grease fitting at the end of the spindle.
3. Pump the grease into the fitting as you continue pressure you will notice the old grease coming out at the cap. When you begin to see the new grease, remove the gun and clean off any excess and replace the rubber cap.

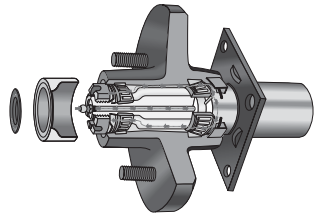

Quality Suspension Systems

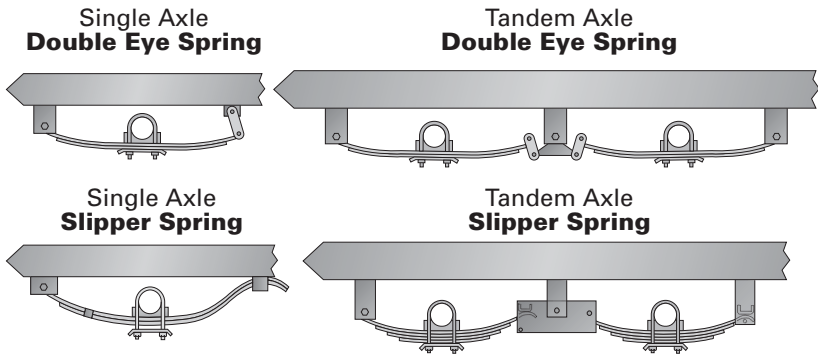

We also provide your suspension systems as well as the axle assemblies. These components are designed to perform a number of tasks to provide your trailer with the best and smoothest towing possible. The above drawings offer a view of single and tandem axle assemblies in both the double eye and slipper spring versions. Your axle undercarriage may be equipped with double eye leaf springs or slipper leaf springs depending on the manufacturer's specification. Double eye leaf springs have eyes at both ends of the spring and have special bushings to protect them from wear. They do not need lubricating. Slipper leaf springs have an eye at only one end which is also fitted with a special bushing to protect them from wear. The trailing end of the spring is designed to slide against the rear hangers. Either of these suspensions will provide you with comfortable trouble free towing, but as with any mechanical parts, they should be inspected periodically, depending on usage, at recommended intervals of 6 months or 5,000 miles whichever comes first. Should you find excessive wear in the hanger components you should have them replaced by a qualified technician. Should you find excess wear, in any of the attaching parts, bolts, nuts, bushings, broken or worn out springs, you should replace them and torque attaching bolts to the following standards as shown below.



MAKE SURE THE TRAILER IS RAISED AND SUPPORTED ACCORDING TO THE MANUFACTURERS REQUIREMENTS BEFORE BEGINNING ANY REPAIRS OF THE TRAILER.

Suspension Torque Requirements

U-BOLT	TORQUE
3/8"	30-50 ft. lbs.
7/16"	45-70 ft. lbs.
1/2"	45-70 ft. lbs.
9/16"	60-85 ft. lbs.
Shackle Bolt	Torque
7/16"	45-70 ft. lbs.
9/16"	not torqued; snug fit to allow parts to move easily. The lock nut is used to position parts.



IF THE ABOVE MAINTENANCE PROCEDURES ARE NOT APPLIED, THERE COULD BE SERIOUS DAMAGE TO THE COMPONENTS POSSIBLY RESULTING IN PHYSICAL INJURY AND OR DAMAGE TO PROPERTY.

To perform undercarriage modifications please carefully follow the recommendations as follows:

1. Raise and support the trailer until it is clear of the ground.
2. When the trailer is securely supported place a block under the axle close to the end which will be repaired. You need to secure only the axle tube in order to remove and replace the part you want to replace. If your trailer has two axles you will need to support both axle tubes.
3. Disassemble the attaching parts (u-bolts, nuts, and the links).
4. Remove the eye bolts and the springs and place them clear of your working area.
5. If needed remove the spring bushings and replace with new ones.
6. Use the reverse order to reinstall your components.

Special note: The fittings that attach the springs to the chassis mounts are designed specially to be wear resistant and should not be lubricated.

The Equalizer Torsion Axle

Your trailer may be equipped with our Equalizer axle(s). The Trailer manufacturer specifies their use according to individual engineering requirements. Each spindle is attached to a trailing arm which rocks up and down during road shock. This movement is transferred to a steel inner bar within the axle beam. Rubber cords then absorb the shock from the twisting inner bar.

EQUALIZER

The Benefits

Superior Performance

The independent action provides greater control and stability which makes towing the trailer much easier. Wheel vibration is absorbed by the rubber cords.



Wheel And Tire Safety

Your trailer manufacturer has specified the wheels and tires to be used. It is very important that you do not make any changes that may alter the recommended size or load capacities. Any deviations, however slight or unnoticeable, may cause damage or be dangerous to operate.

Tightening Procedure

1. After mounting a wheel over the studs, start all lug nuts by hand to prevent cross threading.
2. After all the lug nuts have been snugged, tighten the nuts to the recommended torques using the sequence and progressive values provided below. Re-torque after first 50 miles of use, and periodically recheck the torque.

Torque Requirements

It is a necessary procedure to periodically check the torque levels of your wheel lug nuts. They must be maintained at the appropriate torque recommendations to prevent loose wheels, potentially broken studs and to prevent the wheel from separating from the axle.

Tire Pressure

Tire pressure should be checked frequently, and inflated to the tire manufacturer's recommendations.

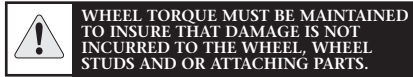

Required Wheel Torques (Ft – Lbs)

	1ST SETTING	2ND SETTING	FINAL SETTING
8-12-13" Wheel	20 — 25	35 — 40	50 — 75
14-15-16" Wheel 1/2" studs	20 — 25	50 — 60	90 — 120
16" Wheel 9/16" studs	20 — 25	70 — 80	130 — 150

Bolt Tightening Sequence

4 Hole Pattern

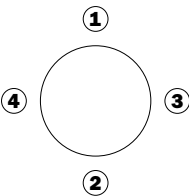

5 Hole Pattern

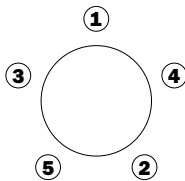

6 Hole Pattern

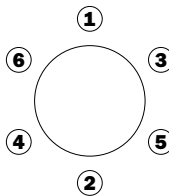

8 Hole Pattern

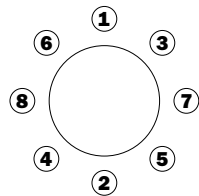

Replacement Parts

Magnet Replacement Kits

BRAKE SIZE	MAGNET KIT NUMBER	WIRE COLOR	BRAKE MTG. NUT TORQUE (FT-LBS)
7 x 1 1/4	K71-57	White	45-70
10 x 2 1/4	PPBM10E	Green	45-70
12 x 2	PPBM12E	White	25-50
12 x 3 1/2	4738-23	Orange	60-90

Brake Shoe Replacement Kits

BRAKE SIZE	SINGLE KIT (1 BRAKE)
7 x 1 1/4	K71-45
10 x 2 1/4	PPDSL10E
12 x 2	PPBSL12E
12 x 3 1/2	right side 4737-3, left side 4737-4

Bearing Replacement Cups & Cones

BRAKE SIZE	HUB	CUP	CONE
7 x 1 1/4	4 or 5 Bolt	L-44610 Inner and Outer	L-44649 Inner and Outer
10 x 2 1/4	5 or 6 Bolt	L-68111 Inner and L-44610 Outer	L-68149 Inner and L-44649 Outer
12 x 2	6 Bolt	25520 Inner and 15245 Outer	25580 Inner and 15123 Outer
12 x 2	8 Bolt	25520 Inner and 14276 Outer	25580 Inner and 14125A Outer
12 x 3 1/2	8 Bolt	25520 Inner and 02420 Outer	25580 Inner and 02475 Outer

Seal Replacement

BRAKE SIZE	HUB	SEAL
7 x 1 1/4"	4 or 5 Bolt	12192TB
10 x 2 1/4"	5 or 6 Bolt	171255TB
12 x 2"	6 or 8 Bolt	22333TBN
12 x 3 1/2"	8 Bolt	22333TBN Grease 370219A Oil

Troubleshooting Guide For Electric Brakes

<p>Dragging Brakes</p>	<ul style="list-style-type: none"> • Check for defective controller. • Check for corroded brake assembly. • Check for weak or broken brake shoe return springs. • Check for worn or damaged lever arm between magnet and brake shoes. • Check for improper controller installation.
<p>Noisy Brakes</p>	<ul style="list-style-type: none"> • Check brake adjustment. • Check for worn brake shoes. • Check for contaminated brake linings. • Check for weak or broken brake shoe return springs. • Check for bent backing plate. • Check wheel bearing adjustment. • Check for worn or damaged wheel bearings. • Check for worn or damaged magnets.
<p>Inoperative Breakaway System</p>	<ul style="list-style-type: none"> • Check for dead or weak 12-volt battery, on trailer. • Check all wiring and connections. • Check breakaway switch. • If only one brake is operating, check other magnets.
<p>No Brakes</p>	<ul style="list-style-type: none"> • Check for defective circuit breaker. • Check for open or shorted circuit. • Check for properly wired system including a good ground between towing vehicle and trailer. • Check brake adjustment. • Check for worn or defective magnet(s). • Check for a damaged or worn connector between towing vehicle/trailer. • Check that controller is installed correctly and functioning correctly.
<p>Intermittent or Surging Brakes</p>	<ul style="list-style-type: none"> • Check for out-of-round brake drums. • Check for properly wired system, including a good ground between towing vehicle and trailer. • Check for defective magnet or wiring. • Check for loose/worn wheel bearings.
<p>Ineffective or Weak Brakes</p>	<ul style="list-style-type: none"> • Ensure trailer is not overloaded. • Check for loose or corroded connections. • Check for properly wired system. • Check for a shorted circuit. • Check for worn or defective magnet. • Check brake adjustment. • Check for bent backing plate flange. • Check for contaminated brake linings. • Check brake system wiring. • Check for worn, damaged brake linings. • Check for weak or broken brake shoe return springs. • Check for worn brake drums. • Check that correct controller is installed. • Check for improper controller installation.
<p>Grabbing or Locking Brakes</p>	<ul style="list-style-type: none"> • Check for contaminated brake linings. • Check for weak or broken brake shoe return springs. • Check for rust on armature plate or brake drum. • Check for improper controller installation.

10,000 lb to 16,000 lb Axle Capacity

Electric Brakes

If equipped, your trailer's electric brakes are actuated by an electromagnet which is controlled by the electrical impulses from the brake controller. The trailer brakes will apply smoothly and slightly ahead of the truck brakes if all the brake components are installed and connected properly.

Theory of Operation

When electrical current is sent to the magnets the activated magnet will contact the rotating armature surface of the brake drum. This contact moves the actuating arm against the cam above the anchor pin. This forces the primary shoe to engage. Pressure from the primary shoe will be transmitted through the adjuster linkage and engages the secondary shoe. As brake pressure (applied by the driver) is increased, the electrical flow to the magnets increase the pressure between the brake linings and drum. As the linings wear the brake will automatically adjust to the proper setting.

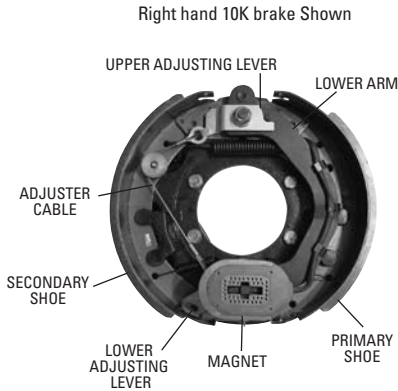

Brake Specifications

BRAKE	PRI. LINING CODE	SEC. LINING	AMPERAGE
12.25 x 3.5	GG	GG	3.2 - 3.5
12.25 x 5	GG	GG	3.5 - 3.5

The GG lining code used on your brakes provides both a static and dynamic coefficient of friction of 0.5. This friction is 20% higher than the common FF linings therefore your brakes will provide superior stopping power, but also generate more heat. The amperages listed above are measured at 12 volts DC. Your amperage may be measured by using the formula:

$$\text{Amperage} \cong \frac{\text{Voltage (at magnet)}}{4}$$

Both outside temperature and use can affect the amperage. Under constant load the amperage will decrease slightly. This is not uncommon and it should return to normal after cooling.

Brake Installation

All electric brakes should be installed using Grade 8 bolts. The OEM bolt torque specifications are shown on page 24.

Note: When installing brakes the magnet wire should always be to the rear of the axle. Once the brake is bolted to the axle the wires should be connected using approved electric connectors. There is no polarity so either wire can be connected to the ground wire.

Brake Shoe Inspection

Periodic inspections of the brake shoes should be done to check for wear. This preventative check will help to prevent further damage to the brake system. When working with brake shoes wear appropriate breathing protection to avoid inhaling the brake dust.

- A normal wear pattern is for the rear pad to be slightly more worn than the front pad. Additionally the brake should appear to have more wear near the middle of the shoes.
- Some heat cracking in the pad is normal, and is not a cause for concern. If the brake shoes are glazed in appearance, they may be roughed up by using a wire brush and rough grit sand paper.
- Brake shoes should be replaced if:
 - The pads are oily or soaked in grease
 - Less than 1/16th" of lining remaining.
 - The shoe (metal portion) itself appears to be bent or worn.
 - The linings should be inspected for any evidence of separation from the shoe backing.
 - There are deep gouges or grooves cut into the pad material.
- Brake shoes should always be replaced in pairs. This will help ensure that the braking system is uniform. After a shoe replacement repeat the burnish process as indicated on page 20.

REPLACEMENT SHOE KITS

Brake Size	Shoe Kit Part Number
12.25 x 3.5	4738 - 2 (Left) /3 (Right)
12.25 x 5	4741 - 2 (Left) /3 (Right)

Magnet Inspection

Periodic inspections of the brake magnet should be done to check for abnormal wear or damage. This preventative check will help to prevent further damage to the brake system. A straight edge will aid in this inspection. If any of the coils are visible replacement of the magnet is required. In addition to the visual inspection it is recommended to check the current draw of the magnets as well. Amperage ranges are listed on page 11.

REPLACEMENT MAGNET KITS

Brake Size	Magnet Kit
12.25 x 3.5	4738 - 23
12.25 x 5	4738 - 23

Disc Brakes

If equipped with electric over hydraulic disc brakes, your brakes are actuated by hydraulic fluid line pressure provided by the hydraulic actuating unit. This unit is controlled by the electrical impulses from the brake controller. The trailer brakes will apply smoothly and slightly ahead of the truck brakes if all the brake components are installed and connected properly.

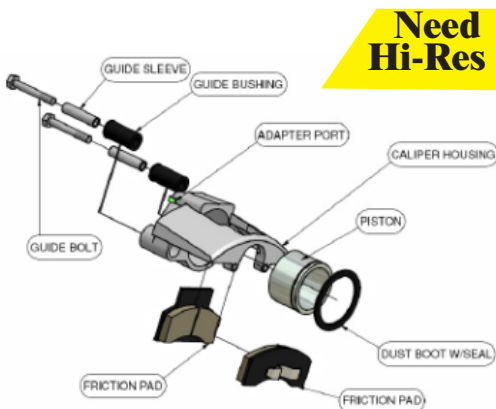

Theory of Operation

Rockwell American axles with disc brakes utilize a floating caliper design. When the actuating unit provides pressure to the piston, the piston forces the inner friction pad against the rotor (rotor not shown for clarity). As the pressure builds the caliper will slide along the guide bolts and cause the outer friction pad to also contact the rotor. This clamping pressure forces the rotor to stop turning. It is important that the actuating unit and brake controller be rated for the disc brake application.

Make sure your controller is installed according to the manufacturer’s recommendations

- Make sure that the proper brake controller adjustments have been made to correctly engage the tow vehicle brakes and the trailer brakes to work together providing safe and comfortable braking.
- Make sure the trailer brakes are grounded properly to the tow vehicle.



Brake Setup and Use

Burnishing - Burnishing is necessary to ensure proper seating and wear in of the brake components. Burnishing is accomplished by applying the trailer brakes to reduce the vehicle speed by 20 mph 20-30 times. For example: reduce speed from 40 mph to 20 mph. Allow ample time between burnish snubs to allow brake to cool and prevent glazing. This should be done in a low traffic area for safety.

Adjustment - the OEM electric brakes standard on our 10,000 lb capacity and above axles are self adjusting. If the adjuster is not functioning as desired, adjusting the brakes manually is an option. This can be done by turning the star on the brake adjuster.

1. Lift trailer and secure on jack stands.
Please follow the trailer manufacturer’s guidelines on lifting locations.
2. Remove the rubber plugs behind the adjuster wheel.
3. Using a flat headed screw driver press the lower adjuster lever outward so that it will not prevent adjustment.
4. Using a brake spoon or screwdriver adjust the brakes so that they expand and the wheel no longer spins.
5. Adjust the brakes inward so that a slight drag is present.
6. Repeat on remaining wheels and lower trailer.



Hubs & Drums

Drum Identification

Axle hubs are generally broken down into categories based on axle capacity and hub pilot. There are two different hubs available on 10,000lb and 12000 lb axles.

AVAILABLE HUBS

CAPACITY	AVAILABLE WHEEL PILOTS	BOLT CIRCLE
10K	4.75"	8 on 6.5"
10K	4.88"	8 on 6.5"
12K	4.75"	8 on 6.5"
12K	4.88"	8 on 6.5"

AVAILABLE HUBS

CAPACITY	AVAILABLE WHEEL PILOTS	BOLT CIRCLE
16K	221mm	8 on 275mm
16K	6.50"	10 on 8.75"



An additional two combinations are solely available on 16,000 lb capacity axles. Since each of these hubs has a different profile, they are not interchangeable on the axle. You cannot convert from one bolt pattern to the other.

Drum Inspection

Periodic drum inspection should be done to check for wear. The 2 surfaces that are to be checked are the brake shoe contact area and the drum armature surface. These surfaces should be checked for uneven/excessive wear and abnormal scoring or gouging. For the shoe contact area, if any drum is worn more than 0.020" oversized or 0.015" out of round, the drum should be resurfaced. If the drum has worn to a diameter of more than 12.340" or after resurfacing would be more than 12.340" the drum would need to be replaced. The armature surface needs to be resurfaced if it is worn unevenly, do not remove more than 0.030" from this surface. After resurfacing the surface finish should be no more than 120 micro inches. If the armature surface is refinished the magnets must also be replaced to prevent further damage. On 10k axles the armature surface is separate from the drum and can be replaced.

- Inspect and clean hub cavity to ensure all metal shavings have been removed.

Bearings

Rockwell American uses industry standard tapered roller bearings in our axles. The use of tapered roller bearings, as opposed to ball bearings, helps reduce axial endplay and is essential to good performance and long bearing life.

Bearing Maintenance

Axle bearings should be checked periodically to extend bearing life. This will also help catch major problems before they happen. In order to check the bearings the hub/drum must be removed. Simply injecting more grease or oil into the axle will not prevent all problems.



Hub Removal

1. Lift trailer and secure on jack stands. Please follow the trailer manufacturer's guidelines on lifting locations.
2. After lifting and securing the trailer, remove the wheels.
3. Remove the plastic oil cap using the appropriate socket, or wrench.
4. Remove the cotter pin.
5. Remove the spindle nut using a 2 1/4" socket (10,000 lb axles) or a 2 1/2" socket (12,000 lb- 16,000 lb axles).
6. Remove spindle washer
7. Using a hub puller, remove the hub from the axle. (The seal may make removal difficult otherwise) The seal may separate.

Seal Removal & Installation

The seal must be replaced after each removal to prevent failure.

1. Pry the seal out of the hub using a screwdriver. Take care to avoid scratching the sealing surface of the hub or the inner bearing.
2. If the inner rubber portion of the seal remains on the spindle pry off using pliers. Take care not to scratch or damage the spindle. Crocus cloth may be used to polish spindle if necessary.
3. Tap the seal into place using a wood block or seal installation tool.
4. DO NOT use sealant on seal surfaces.

Bearing Inspection

Cleaning the bearings thoroughly will make inspection easier. Use a lint free cloth to dry.

1. Inspect inner ring for wear, corrosion, or excessive heat.
2. Inspect individual rollers, by rolling in hand, for pitting, spalling, or corrosion. Do not spin using compressed air
3. Check cage for cracks or other damage.
4. If any of the above damage is found then replace bearing and corresponding race.

Race (bearing cup) Removal & Installation

It is important that bearings and races be replaced in pairs to avoid pre-mature failure.

1. Place the hub on a flat surface with the race to be removed facing downward.
2. Using a soft brass punch, tap around the top surface of the race until the race is dislodged, taking care not to damage other surfaces.
3. Clean hub thoroughly to ensure that no metallic flakes or lint is left inside the hub.
4. Install the new race by tapping in with a soft brass punch. Verify that the race is seated fully in the hub.

Bearing Inspection

1. Inspect raceway for wear, corrosion, or excessive heat.
2. If any damage is found replace the race and corresponding bearing.

Bearing Installation & Adjustment

Once the components have been replaced the following procedures must be done to complete installation. If your hubs are grease packed, repack prior to installation. See below “Grease Packing Bearings”.

1. Install hub onto axle once inner bearing and seals have been installed. Take care not to damage the inner seal on the spindle threads
2. Install the outer bearing by sliding it over the spindle.
3. Install the spindle washer.
4. Start the spindle nut by hand
5. Tighten the spindle nut using a 2 1/4” socket (10,000 lb axles) or a 2 1/2” socket (12,000 lb-16,000 lb axles).
6. Using a torque wrench torque the spindle nut to 100 ft-lbs.
7. Back the spindle nut off 1/4 of a turn and align the cotter pin hole with the spindle nut.
8. Insert the cotter pin and bend one leg of cotter pin over the end at the spindle and the other leg over the nut. Tap legs slightly to set.
9. Tighten the plastic oil cap to 20 to 30 ft-lbs.
10. Refill with oil (if equipped).
11. Re-install wheels per instructions on page 24.

Lubrication

Rockwell American offers two types of bearing lubrication on these assemblies. In addition to checking during bearing inspection and replacement it is important to routinely check the lubrication in your hubs

Oil

If equipped with oil bath hubs (clear caps) the oil level should reach the fill line on the cap after the trailer has been stationary and the oil has pooled. Overfilling the hub does not provide extra protection. Oil may be added by removing the rubber plug located in end of cap. It is recommended that only high quality non-synthetic SAE 80-90w gear oil be used to refill oil bath axles. The OEM oil is red in color to aid in visibility. See page 25 for oil specifications and recommended sources.

Grease

If equipped with greased hubs (blue caps) the condition of the grease should be checked to ensure proper bearing life. It is recommended that only high quality NLGI 2 grease be used to repack bearings. See page 25 for grease specifications and recommended sources.

Grease Packing Bearings

Hand pack each bearing or use a bearing packing tool. To pack by hand do as follows:

1. Place grease into the palm of your hand.
2. Press and work grease in between the individual rollers. This is done more easily by forcing through at the widest side of the bearing.
3. Repeat for each roller taking care to rotate the bearing as this is being done. The entire bearing should be full of grease.
4. Liberally coat the race (bearing cup) with grease.

Suspensions

With most axles of these capacities Quality also provides the suspension system as well as the axle. These components are designed to perform a number of tasks and to provide your trailer with the best and smoothest towing possible. Not all types of suspension are available on all axles.

Air Ride Axles & Other Types.

Please refer to the trailer manufacturer for details.

Slipper Springs

The most common type of undercarriage is the slipper spring configuration. These axles are installed in single, tandem, spread, or triple configurations. Slipper springs have an eye only at one end which contains a rubber bushing to aid in wear. The trailing end of the spring is designed to slide against the rear hanger.

Torsion Equalizer Axles

Your trailer may be equipped with our Equalizer axles. These axles rely on a rubber suspension with superior dampening characteristics to provide a smooth reliable ride. They are designed to meet nineteen individual customer requirements. This is a self contained system and should not be modified. These axles should be bolted to the frame using the brackets. Secondary attaching brackets are provided per customer request.

Inspection & Replacement

It is important to periodically check the suspension components of the slipper spring axles to ensure that they are not worn. Any components with excessive wear or damage should be replaced.

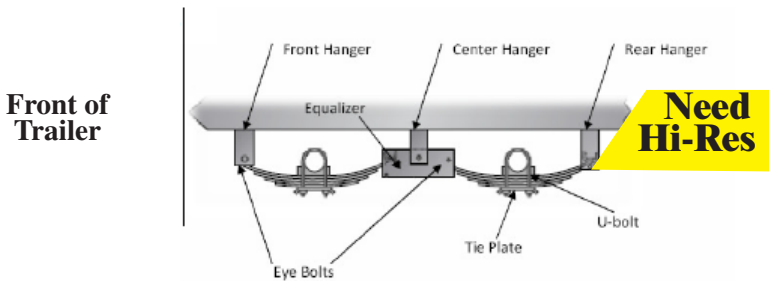

To remove the springs or any spring component please refer to the instructions below.



1. Once the trailer is properly lifted and secured place a jack stand or block under the axles near the ends to be repaired. These rests are only to support the axles and suspension and will remove the load from them. They do not support the trailer.
2. Remove the u-bolt nuts and disassemble the u-bolts and tie plates from the axle.
3. Remove the eye bolts from the spring and slide the spring out.
4. If only the eye bushings are to be replaced use either a c-clamp or vice to press the worn bushing out.
5. Installation of the new bushing is the reverse of removal.
6. Installation of the spring is the reverse of removal. See torque specification on page 24 for component requirements.

Equalizer Replacement

To remove the equalizer bar or any equalizer bar component please refer to the instructions below.



FAILURE TO PROPERLY LIFT AND SECURE TRAILER AND SUSPENSION MAY CAUSE PERSONAL INJURY OR DEATH.

1. Once the trailer is properly lifted and secured place a jack stand or block under the axles near the ends to be repaired. These rests are only to support the axles and suspension and will remove the load from them. They do not support the trailer.
2. Remove the spring eye bolts and equalizer bolts.
3. Remove the equalizer bar.
4. If only replacing the equalizer bushings use either a c-clamp or vice to press the worn bushings out.
5. Installation of the new bushing is the reverse of removal.
6. Installation of the equalizer is the reverse of removal. The equalizer bolt utilizes a lock nut which should be replaced. See torque specification below for component requirements.

Wheels & Tires

Torque values on lug nuts are required and adhering to the proper torque values and schedule is of the utmost importance. Also of extreme importance is the selection of the proper wheel mounting pilot diameter on hub piloted wheels.

1. Mount wheels
2. Start all nuts by hand to prevent cross threading and other damage.
3. After all lug nuts have been “snugged”, tighten the nuts to the recommended torques using patterns shown below. Take note to select the proper mounting type.
4. Nuts should be tightened in stages of 20% of final torque, 50%, and 100%.
5. Check and re-torque nuts after 25 miles and 50 miles, and then periodically.



FAILURE TO PROPERLY TORQUE LUG NUTS CAN RESULT IN PERSONAL INJURY OR DEATH.



FAILURE TO SELECT PROPER WHEEL PILOT CAN RESULT IN PERSONAL INJURY OR DEATH.

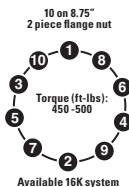
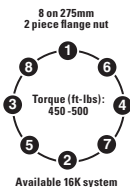
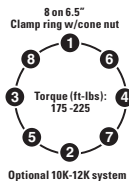
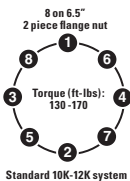

Torque Requirements

ITEM	SIZE	TORQUE (FT-LBS)
U-bolt - 10K	5/8" - 11	90-110
U-bolt - 12K & 16K	3/4" - 10	130 - 170
Spring Eye Bolt	3/4" - 16	0-1/16" End Play
Equalizer Eye Bolt	1" - 8	0-1/16" End Play
Equalizer Bolt - 10K	1 1/8" - 7	0-1/16" End Play
Equalizer Bolt - 12K & 16K	3 3/4" - 8	20 - 30
Plastic Cap	3 3/4" - 8	20 - 30
Torsion Mounting Bolts	1/2" - 13	90 - 110
Brake Nuts	1/2" - 20	90 - 110
Lug Nuts	10K	120 - 170 lbs.
Lug Nuts	12K	130 - 170 lbs.
Lug Nuts	16 K	450 - 500 lbs.

Storage & Infrequent Use

Prolonged or even short term storage can affect multiple wear items on the trailer. The most common items affected are seals, bearings, and tires. Oil bath axles need to be moved in order allow the oil to fully lubricate the bearings. It is highly recommended that the hubs be rolled at least once every two weeks to prevent oil pooling and oxidation on the bearings.

Storage Preparation

1. Follow the trailer manufacturer's guidelines for lifting and supporting the trailer in order to remove the load from the trailer tires. Do not place supports on axle beams.
2. If axle has been immersed in water, remove the hubs clean and lubricate bearings and re-install.

After Storage

1. Inspect the suspension system, for worn bushings and loose bolts.
2. Remove drums and check for wear and remove any oxidation with emery cloth.
3. Inspect brake assembly for cracked linings, worn magnets, free movement of parts, and oxidation. Clean and replace as necessary.
4. Remove seal and inspect bearings and races.
5. Replace seal and complete re-assembly of drum
6. Mount and torque wheels per specifications. See page 24.

Oil & Grease Specifications

GREASE

SPECIFICATION	CHARACTERISTIC
NLGI Grade Number	2
NLGI Certified, ASTM D 4950	GC-LB
Dropping Point (ASTM D 2265)	500° F
Color	Blue/Red
Thickener	Lithium Complex
Viscosity Index	80
Additives	EP/Anti-wear, Rust and Oxidation Inhibited

COMMON SOURCES

CITGO	Lithium Complex Grease, EP No. 2
Mystik Oil Company, Inc.	JT-6 HI-TEMP Grease No. 2
Exxon Mobil	Mobil 1 Synthetic Grease
Conoco Phillips	Multiplex Red No. 2
Pennzoil	Premium Wheel Bearing Grease 707L Red
Valvoline (Ashland, Inc.)	Multi-Purpose Grease GM (General Motors)

OIL

SPECIFICATION	CHARACTERISTIC
SAE Grade Number	90
Flash Point, ASTM D 92	400° F
Color	Red/Amber
Viscosity Index, ASTM D 2270	115
API Service Classification	GL-4

COMMON SOURCES

CITGO	CITGEAR Standard XD
H&B Industries	HB-1160 Starfilm EP Gear Lube
Mystik Oil Company, Inc.	Mystik Power Lubricants
Mystik Oil Company, Inc.	GEARPLUS SAE 80w-90 GL-4
Shell	Spirax GX

Note: DO NOT mix synthetic and non-synthetic oils.

PARTS LIST

A	U-BOLT	UB95BP
B	SPRING	8131
C	LOCK WASHER	58LW
D	U-BOLT PLATE	10625BZPN
E	HEX NUT	58HN
F	OIL CAP PLUG	RP-200
G	CAP	12011 (OIL) 120G (GREASE)
H	O-RING	V75340
I	OIL CAP ASSEMBLY	12011-1
J	COTTER PIN	CP-3
K	SPINDLE NUT	4797
L	SPINDLE WASHER	4798
M	OUTER BEARING	25580
N	DRUM	99865-1P (4.88) 99865-1P475 (4.75)
O	WHEEL STUD	4738-28
P	LOCK NUT	14LN
Q	ARMATURE BOLT	FL14201
R	ARMATURE PLATE	10KARM
S	DRUM ASSEMBLY	99865-1PA (4.88) 99865-1P475A (4.75)
T	INNER BEARING	28580
U	OIL SEAL	CR27438 (OIL) OB27377 (GREASE)
V	BRAKE ASSEMBLY	4738-L/R
W	BRAKE NUT	12LN
X	LUG NUT	568216

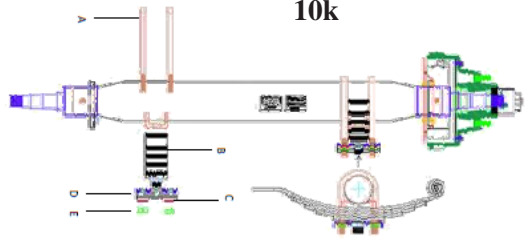

10k

**Need
Hi-Res**

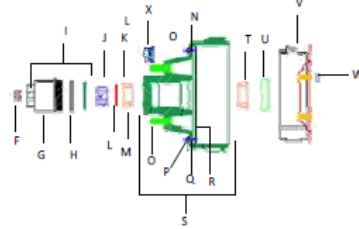

12k

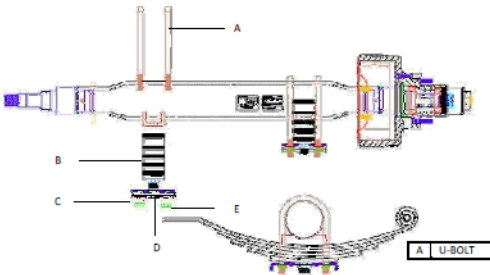

**Need
Hi-Res**

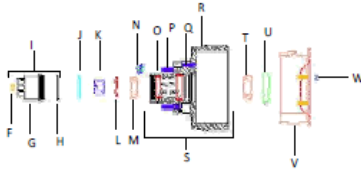

A	U-Bolt	4361-60
B	SPRING	8132
C	LOCK WASHER	34LW
D	U-BOLT PLATE	121625BPN
E	HEX NUT	34HN
F	OIL CAP PLUG	RP-200
G	CAP	12011 (OIL) 1201G (GREASE)
H	O-RING	V75340
I	OIL CAP ASSEMBLY	12011-1
J	COTTER PIN	CP-3
K	SPINDLE NUT	47127
L	SPINDLE WASHER	47128
M	OUTER BEARING	JM205149
N	LUG NUT	568216
O	HUB	812865-1
P	WHEEL STUD	4738-28
Q	ATTACHING BOLT	1215BOLT
R	DRUM	912865-1-DRUM
S	DRUM ASSEMBLY	912865-1 (4.88) 912865-1475 (4.75)
T	INNER BEARING	39590
U	OIL SEAL	CR31281 (OIL/GREASE) OB3145059 (OIL/GREASE)
V	BRAKE ASSEMBLY	4741-L/R
W	BRAKE NUT	12LN

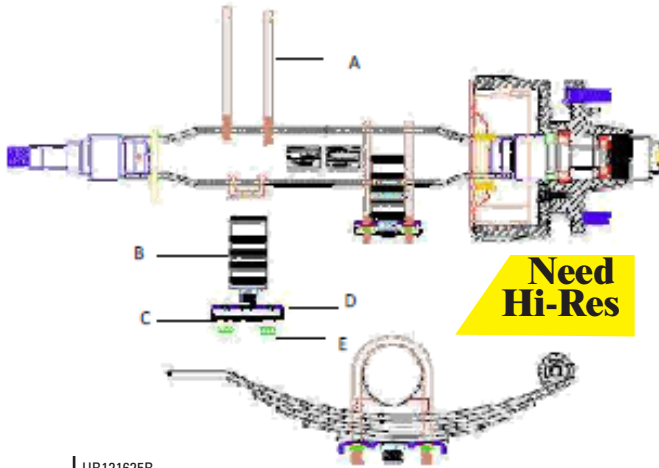

A	U-BOLT	UB121625B
B	SPRING	093182-14
C	LOCK WASHER	34LW
D	U-BOLT PLATE	121625B
E	HEX NUT	34HN
F	OIL CAP PLUG	RP-200
G	CAP	12011 (OIL)
H	O-RING	V75340
I	OIL CAP ASSEMBLY	12011-1
J	COTTER PIN	CP-3
K	SPINDLE NUT	47127
L	SPINDLE WASHER	47128
M	OUTER BEARING	JM205149
N	LUG NUT	09065114
O	STUD RING	4741-10
P	WHEEL STUD	4741-34
Q	HUB	816108-1
R	DRUM	916108-1-DRUM
S	ATTACHING BOLT	1215BOLT
T	DRUM ASSEMBLY	916108-1
U	INNER BEARING	39590
V	SEAL	CR31281 (OIL)
W	BRAKE	4741-L/R
X	BRAKE NUT	12LN

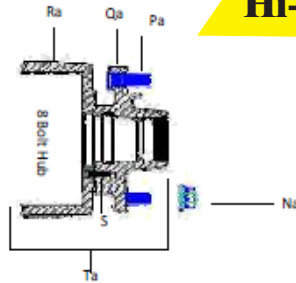
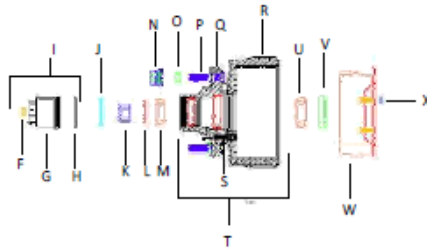

Na	LUG NUT	WN333
Pa	WHEEL STUD	4741-30
Qa	HUB	816810-1
Ra	DRUM	912865-1-DRUM
Ta	DRUM ASSEMBLY	916810-1

Troubleshooting

New trailers are those with less than 250 miles on them or less than 2 weeks old.

NOTE: Some Integrated Brake Controllers Do Not Work On All Braking Systems. Please See Vehicle Owner's Manual For Guidance.

BRAKING

Brakes On New Trailer Seem To Be Inoperative Or Weak _____

- Brakes may still be in the burnish phase if the trailer has less than 250 miles on it. Monitor braking to see if it improves with use.
- Check brake controller and trailer electrical connections for proper setup as well as for open and short circuits.
- Trailer may be overloaded. Check weight or loaded trailer. See page 6 - 7.
- Insufficient current draw by the magnet. Check electrical connections.
- Brake may need to be re-adjusted. See page 20.
- Possible lining contamination. Check brake shoes for contamination

Check magnet for grease or oil. Clean as needed.

Brakes On New Trailer Seem To Drag _____

- Check brake controller, breakaway switch, and trailer electrical connections for proper setup.
- Brake may need to be re-adjusted. See page 20.
- Brake assembly may be mounted improperly.
- Bearings may be too loose. Check bearing adjustment. See page 22.
- Drums may be out of round. Check drum run-out. See page 20.
- Brake lining may have become detached.
- Brake components or other debris may be loose or lodged in drum.

Brakes On Used Trailer Seem To Drag _____

- Check brake controller, breakaway switch, and trailer electrical connections for proper setup.
- Brake may need to be re-adjusted. See page 20.
- Possible lining contamination. Check brake shoes for contamination.
- Brake assembly may be mounted improperly.
- Brake components or other debris may be loose or lodged in drum.
- Brake lining may have become detached.
- Spindle may be bent.
- Check for excessive brake dust in drum. Brake may need to be re-adjusted. See page 31.
- Brake may be seized. If trailer has been not been used recently. Please see section on storage, page 25.
- Check brake linings for wear pattern. See page 19.
- Check that brake components move freely. Lubricate as needed.
- Drums may be out of round. Check drum run-out. See page 20.

Brakes On New Trailer Squeal _____

- If in a humid environment some squeal may be normal.
- Check for excessive brake dust in drum. Brake may need to be re-adjusted. See page 20.
- Brake may be seized; this most often occurs if trailer is several months post manufacture when purchased. Please see section on storage, page 25.
- Check brake linings for wear pattern. See page 19.
- If accompanied by dragging see Troubleshooting - Brakes on new trailer seem to drag.

Brakes On Used Trailer Squeal _____

- If in a humid environment some squeal may be normal.
- Check for excessive brake dust in drum. Brake may need to be re-adjusted. See page 20.
- If trailer has been stored for longer than 3 months please see section on storage, page 25.
- If accompanied by dragging see Troubleshooting, Brakes on used trailer seem to drag.
- Brake shoe may be bent.
- Spindle may be bent.
- Check that brake components move freely. Lubricate as needed.

Brakes On Trailer Seem To Be Warm/Hot _____

Brakes operate in temperature ranges in excess of 400°F. 130°F may cause burns. It is common for new trailer brakes to have 90°F temperature difference between them. Monitor this to see if it goes away.

- Verify that the source of the heat is the drum and not the hub portion of the hub/drum assembly. The drum should be hotter than the hub near the grease/oil cap.
- If this is accompanied by dragging/squealing see previous sections.
- Check brake controller, breakaway switch, and trailer electrical connections for proper setup.

Brakes On New Trailer Lock Up _____

- Check brake controller, breakaway switch, and trailer electrical connections for proper setup.
- Does the trailer have to roll back to release? Brake may be under-adjusted and will need to be re-adjusted. See page 20.
- Brake components or other debris may be loose or lodged in drum.
- Axle and/or brake assembly may be installed incorrectly.
- Possible lining contamination. Check brake shoes for contamination.
- Brake lining may have become detached.
- Bearings may be too loose. Check bearing adjustment. See page 22.
- Drums may be out of round. Check drum run-out. See page 20.

Brakes On Used Trailer Lock Up _____

- Check brake controller, breakaway switch, and trailer electrical connections for proper setup.
- Brake components or other debris may be loose or lodged in drum.
- Axle and/or brake assembly may be installed incorrectly.
- Possible lining contamination. Check brake shoes for contamination.
- Brake lining may have become detached.
- Does the trailer have to roll back to release? Brake May be under-adjusted and will need to be re-adjusted. See page 20.
- Spindle may be bent.
- Brake shoe may be bent, Check shoe lining for wear pattern. See page 19.
- Drums may be out of round. Check drum run-out. See page 20.

Brakes On Trailer Are Intermittent _____

- Check brake controller and trailer electrical connections for proper setup as well as for open and short circuits
- Check for broken wires near pinch points and replace.
- Brake may need to be adjusted. See page 14.

Brakes On Trailer Surge _____

- Possible lining contamination. Check brake shoes for contamination. Check magnet for grease or oil. Clean as needed.
- Drum may be out of round. Check drum run-out. See page 20.
- Check brake controller and trailer electrical connections for proper setup.

Hubs & Bearings

Excessive Vibration When Towing

- Check tires for bulges, flat spots, etc. to rule out faulty tire or out of balance wheel.
- Often vibrations from out of round hubs peak around 50 miles per hour. If this happens check drum for visual distortions.
- Check bearing endplay. Tire tilt should be no more than .005" per inch of tire diameter. End play should be no more than .010".
- Often this is due to a broken suspension component, if none of the above applies. Check u-bolts, bushings, springs, etc.

Excessive Heat From Hub/Drum

Often the source is from the brake assembly. See Brakes on trailer seem to be warm/hot in the Braking section above.

- Spindle nut may be too tight, adjust as needed. See page 22.
- Lack or wrong type of grease/oil.
- Check that lubricant is dark in color. Pale colored grease may be contaminated with water.

Dust Caps Fall Off

- Improper installation. Replace.
- If problem is persistent hub may be defective. Replace hub.

Persistent Seal Leaks

- Improper selection of or bad installation of seal. See page 21.
- Damaged hub housing.
- Damaged spindle. Spindle finish should be below 100 micro inches.

Suspension

Rubber Bushings Wear Pre-Maturely

- Overloaded trailer. See page 6 - 7.
- Bolts holding bushings on are tightened improperly. Verify that bolts are torqued properly. See page 24.
- Hangers are welded on crooked and/or other axle mounting defect. Verify that hangers are welded onto trailer properly and springs are straight.
- Bushing housing is worn and causes bushings to be loose. Verify that holes for bushings meet manufacturer's requirements.

Cracked Bushing Housing

- Overloaded trailer. See page 6 - 7.
- Direct metal to metal contact with no lubricant. Replace components and follow maintenance schedule.

Failed Leaf Spring

- Loose U-bolts. Spring will fail at the center pin between the u-bolts. See torque requirements on page 24.
- Corrosion. Failure locations vary. This is most common in marine applications.
- Fatigue Failure. Shorter leaves will break first.
- Fatigue Failure. Leaf spring has started to flatten out. Replace springs.
- Material flaw. Only determinable by testing.

Failed Torsion Suspension

- Heat applied to axle tube or attaching brackets.
- Overloaded trailer. See page 6 - 7.
- Mixed start angles on tandem axle setup.
- Severe corrosion on axle beam caused by using non-galvanized axle in corrosion prone environments.
- Material Flaw. Only determinable by testing.

Warranty

Rockwell American Limited Warranty

Quality Trailer Products- extends to the original purchaser only, a limited warranty on each Rockwell American axle assembly against defects in material or workmanship for a period of two (2) years from the date of purchase. A warranty period of five (5) years is extended to Equalizer Torsion Axle Suspensions exclusive of wear items (hubs, brakes, bearings, and seals).

To obtain warranty service, please call (800) 334-6355 and provide the following information:

- a. Name and mailing address of purchaser.
- b. Proof of date of purchase.
- c. Name of manufacturer of unit under which the axle was mounted.
- d. Year and serial number of the trailer and axle.
- e. Name and address of dealer whom from the unit was purchased.

1. This Warranty Does Not Extend To:

- a. The connection of brake wiring to the trailer wiring or trailer wiring to the towing vehicle wiring.
- b. The attachment of the axles to the frame.
- c. Hub imbalance or any damage caused thereby.
- d. Parts not supplied by Quality Trailer Products.
- e. Any damage whatsoever if caused by or related to any alteration to the axle.
- f. Use of axle assembly on unit other than that to which it was originally mounted.
- g. Normal wear including hubs, brakes, bearings, or seals.

2. This Warranty Does Not Cover Defects Caused By:

- a. Improper installation.
- b. Damage (not resulting from defect or malfunction) while in the possession of the customer.
- c. Unreasonable use (including failure to provide reasonable and necessary maintenance)

3. Repair or replacement under this warranty is the exclusive remedy of the customer. Quality Trailer Products shall not be liable for any incidental or consequential damages, including towing fees, hotel bills, telephone calls and meals for breach of any express or implied warranty on the axle

4. Some states do not allow the exclusion or limitations of incidental or consequential damages, so the above limitation or exclusion may not apply to you. This warranty gives you specific legal rights and you may have other rights which vary from state to state.



Sales & Service

Replacement parts for Rockwell American axles can be ordered directly from Quality Trailer Products by calling (877) 787-2453 or by visiting any of our 19 Direct Distribution Centers nationwide.

QUALITY TRAILER PRODUCTS SELLING LOCATIONS

ALABAMA

960 Old Grants Mill Rd
Irondale, AL 35210
Phone: (205) 951-2006
Phone: (800) 874-4292
Fax: (800) 655-2944
birmingham@qtrailer.com

FLORIDA

3804 Sydney Rd.
Plant City, FL 33566
Phone: (800) 289-2953
Phone: (813) 659-2948
Fax: (813) 659-9847
plantcity@qtrailer.com

INDIANA

1304 Wohlerst Street
Angola, IN 46703
Phone 260-665-3748
Phone 877-730-3748
Fax 877-730-3748
angola@qtrailer.com

MISSOURI

519 Duck Road
Grandview, MO 64030
Phone: (866) 724-9950
Fax: (866) 724-9956
kansascity@qtrailer.com

MINNESOTA

208 7th Street SW Box 235
Freeport MN 56331
Phone: (320) 836-2550
Phone (888) 325-1485
Fax (320) 836-9550
freeport@qtrailer.com

OKLAHOMA

1801 Ray Davis Blvd.
Seminole, Oklahoma 74868
Phone: (866)724-9950
FAX: (866)724-9956
seminole@qtrailer.com

PENNSYLVANIA

170 Commerce Dr
New Holland, PA 17557
Phone: (717) 354-7070
Phone: (800) 497-0986
Fax: (717) 354-7076
newholland@qtrailer.com

SOUTH CAROLINA

Hwy 76 (Palmetto Indust. Park)
Timmonsville, SC 29161
Phone: (843) 346-4827
Phone: (800) 238-3903
Fax: (813) 659-9847
Fax: (800) 207-4770
florence@qtrailer.com

TEXAS

604 W. Main Street
Azle, TX. 76020
Phone: (817) 444-1341
Phone: (800) 242-4882
Fax: (817) 444-4849
Fax: (800) 889-1435
azle@qtrailer.com

TEXAS

609 East 16th
Mt. Pleasant, Texas 75455
Phone: (903) 572-7932
Phone: (800) 635-1354
Fax: (903) 572-7268
Fax (800) 301-7943
mtpleasant@qtrailer.com

TEXAS

1334 S. General McMullen Dr.
San Antonio, Texas 78237
Phone: (210) 431-0166
Phone: (800) 854-8058
Fax: (210) 431-0188
Fax: (800) 343-1895
sanantonio@qtrailer.com

Dial 877-QTRAILER (877-787-2453) to reach your nearest Quality Branch

CENTURY WHEEL & RIM

ARIZONA

2930 W. Osborn Road
Phoenix, AZ 85017
Phone: (602) 271-0031
Phone: (888) 999-8233
Fax: (602) 271-0148
phoenix@qtrailer.com

CALIFORNIA

2888 South Orange Avenue
Fresno, CA 93725
Phone: (559) 237-7467
Phone: (800) 742-6203
Fax: (559) 237-1913
fresno@qtrailer.com

CALIFORNIA

1330 East Locust Street
Ontario, CA. 91761
Phone: (909) 930-5047
Phone: (800) 624-1715
Fax: (909) 947-7015
ontario@qtrailer.com

CALIFORNIA

3701 Parkway Place
W. Sacramento, CA 95691
Phone: (916) 371-6792
Phone: (800) 321-6362
Fax: (916) 371-0228
sacramento@qtrailer.com

COLORADO

14600 E. 35th Place Unit F
Aurora, CO 80011
Phone: (303) 307-4700
Phone: (800) 307-5944
Fax: (303) 307-4774
aurora@qtrailer.com

OREGON

27180 S.W. 95th Ave. Suite 3320
Wilsonville, OR 97070
Phone: (503) 682-0510
Phone: (800) 914-9116
Fax: (503) 682-0520
wilsonville@qtrailer.com