





















Guarding the Skies
Above Our Cities

75 mm Anti-Aircraft Gun

SKYSWEEPER

134 Parts with Combat Crew of 5

SUPERBLY DETAILED
"HIGH IMPACT" PLASTIC KIT

Exclusive New Design Insures
POSITIVE ASSEMBLY and
"NO SHOW" Cementing

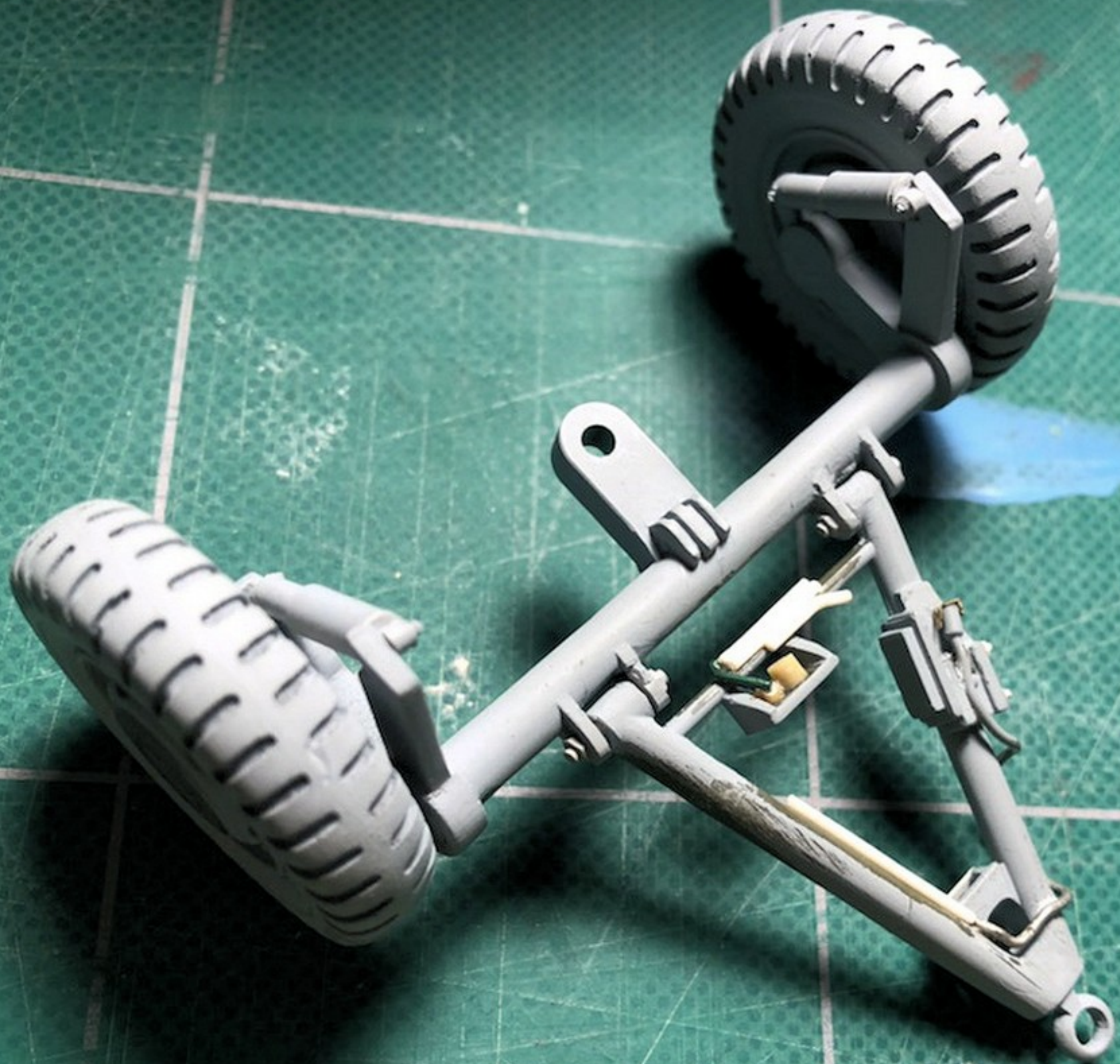
SCALE
 $\frac{3}{8}$ in. = 1 ft.

A FULLY
OPERATING MODEL

Accurately scaled from
U.S. ARMY ORDNANCE
BLUEPRINTS

RENWAL
MINEOLA, N.Y.

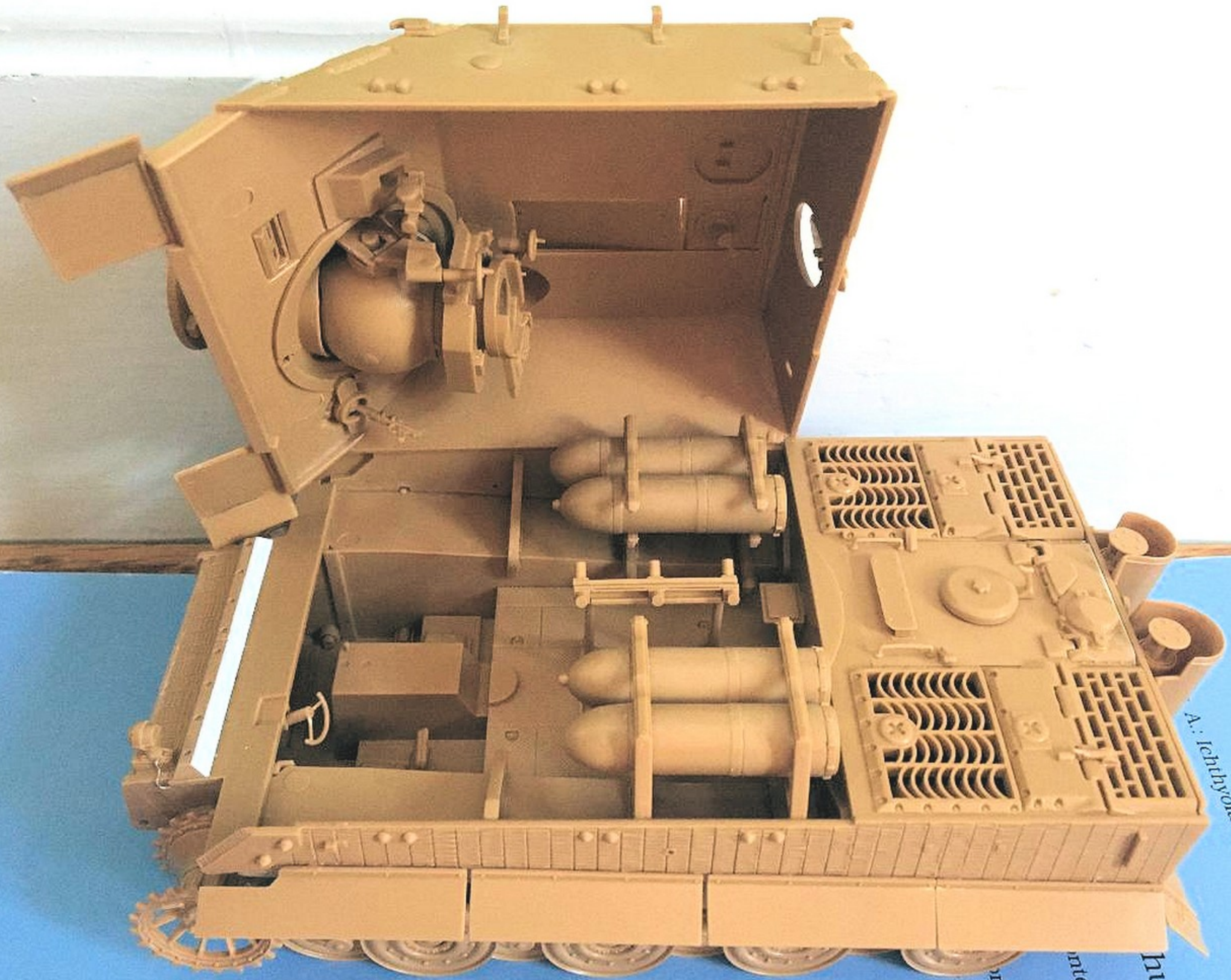








...verfahren aus dem
... sind eing
... indicators 0
... dien: Eine
... digkeitstf

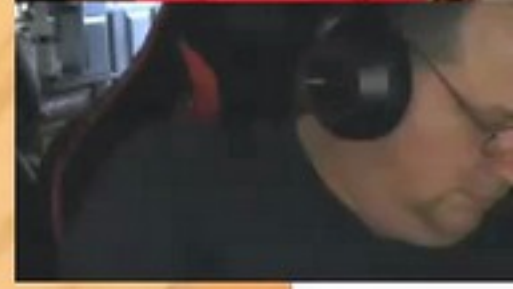
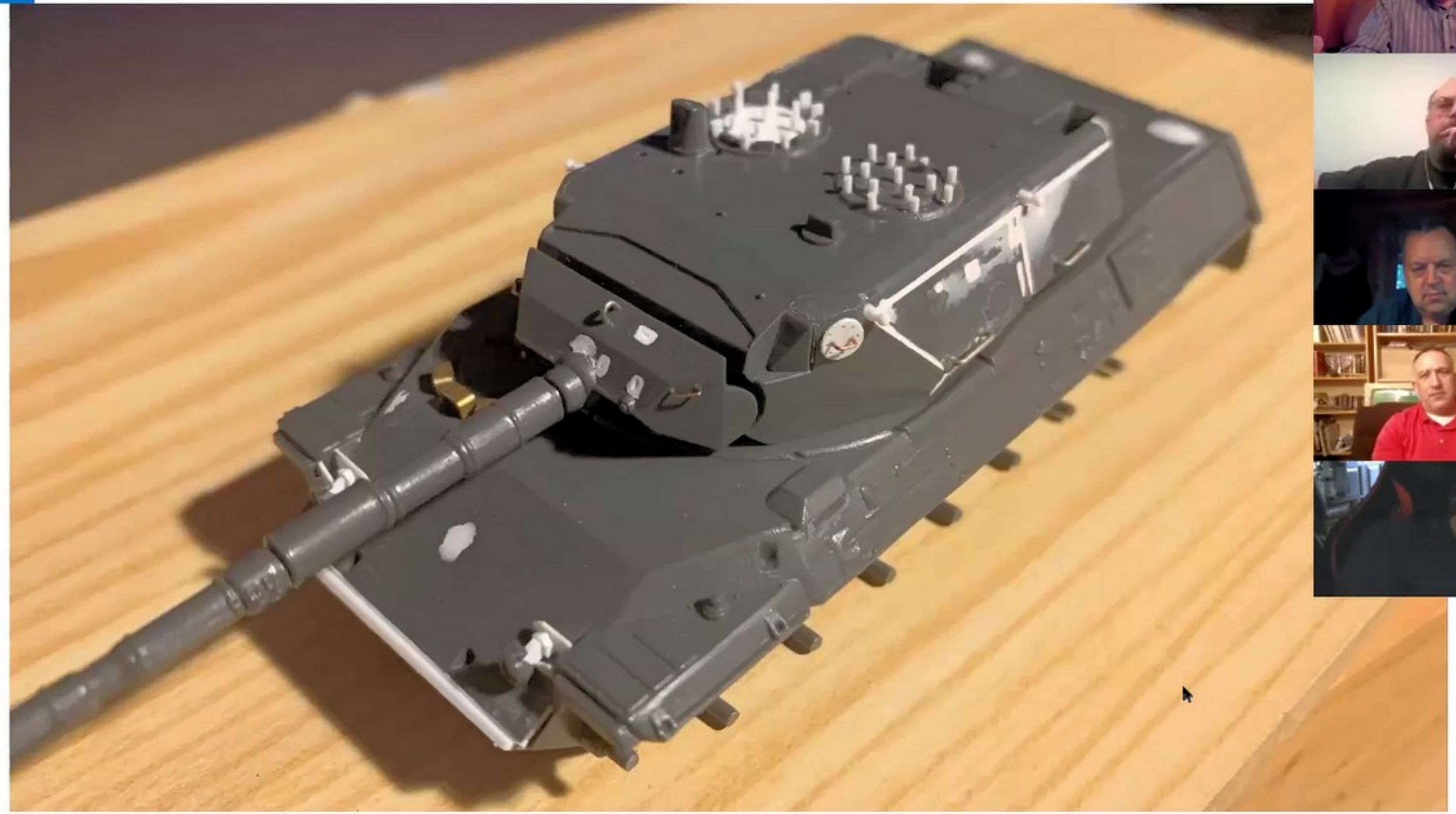


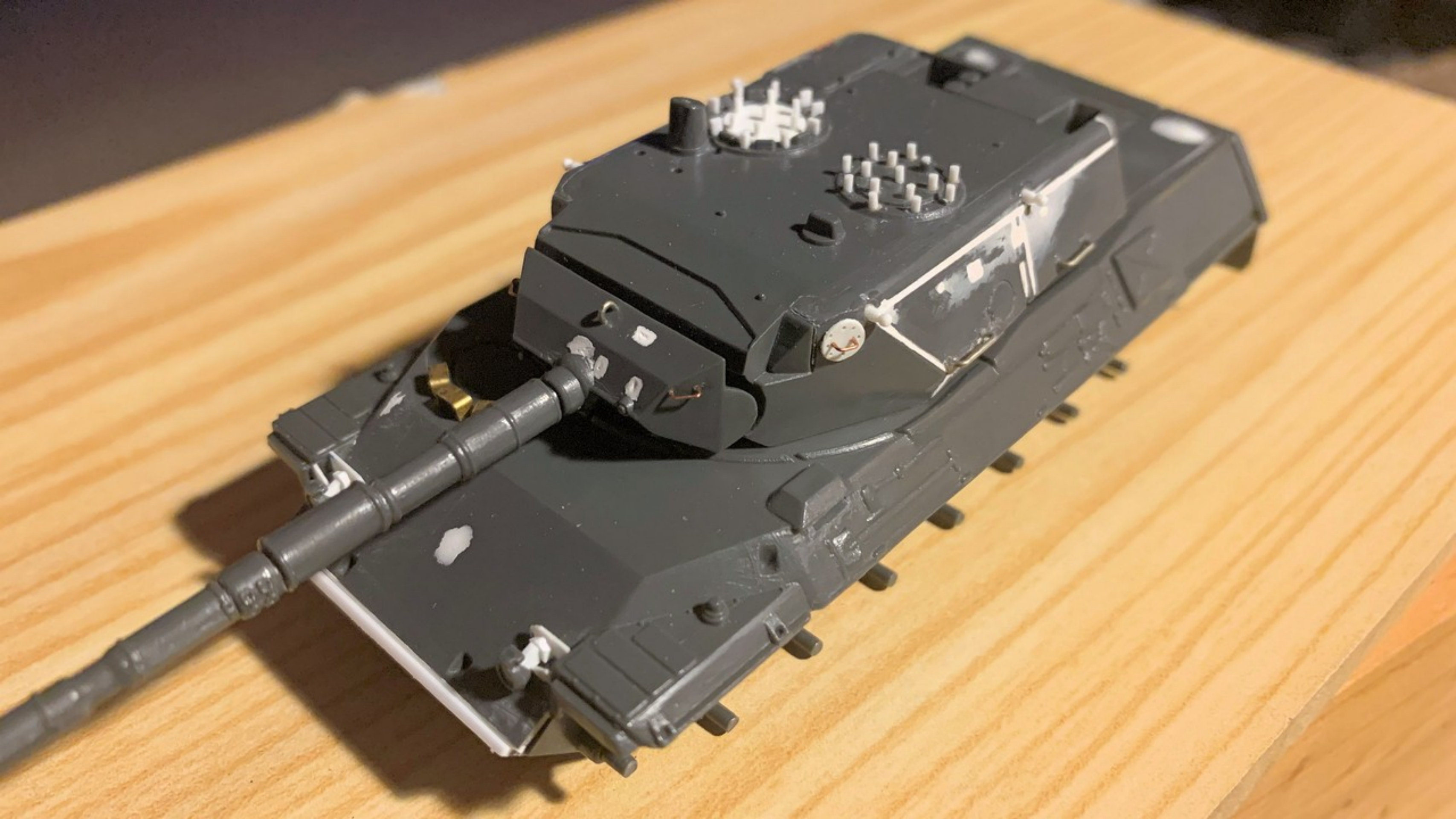
See all photos

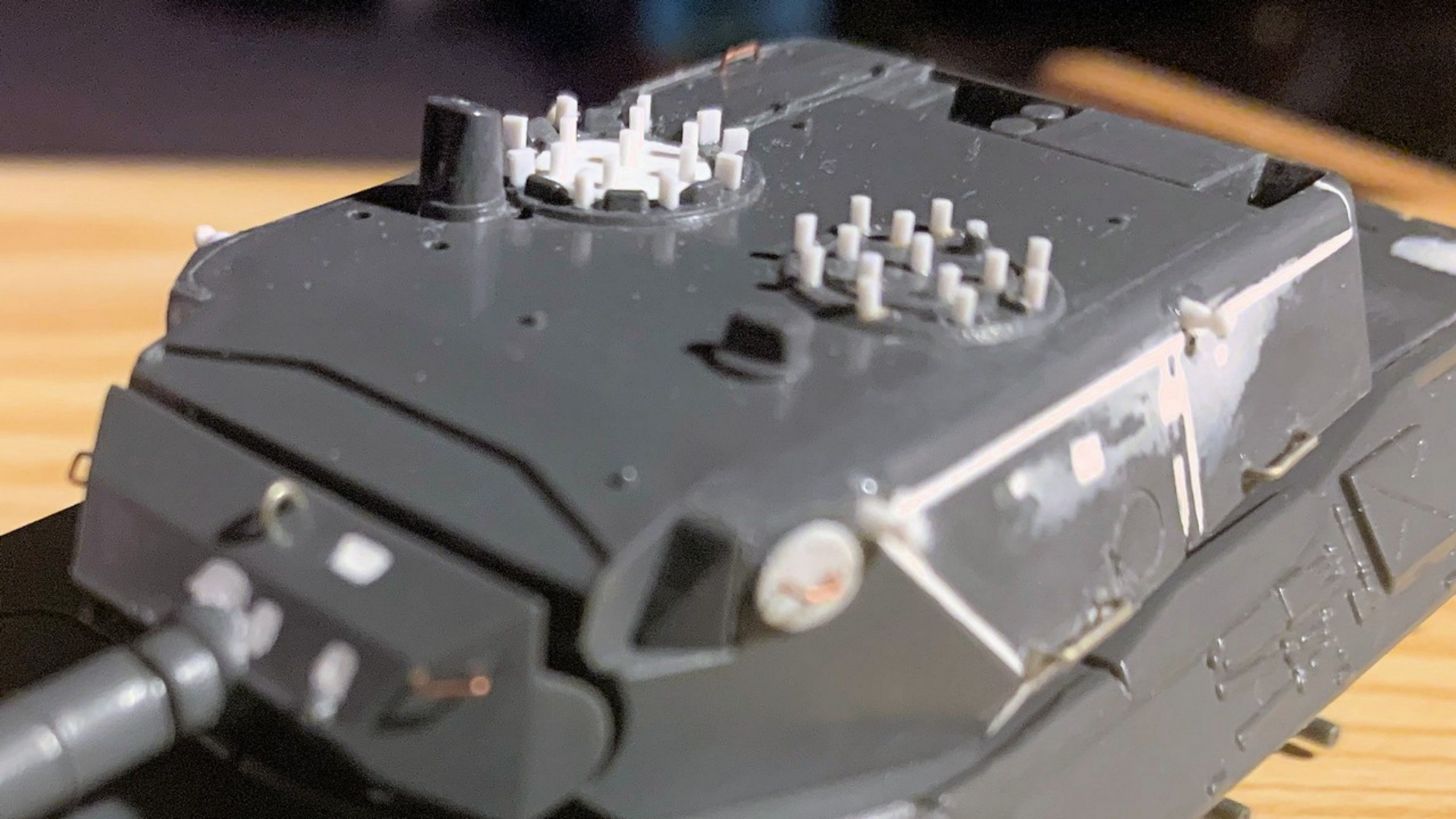
Add to

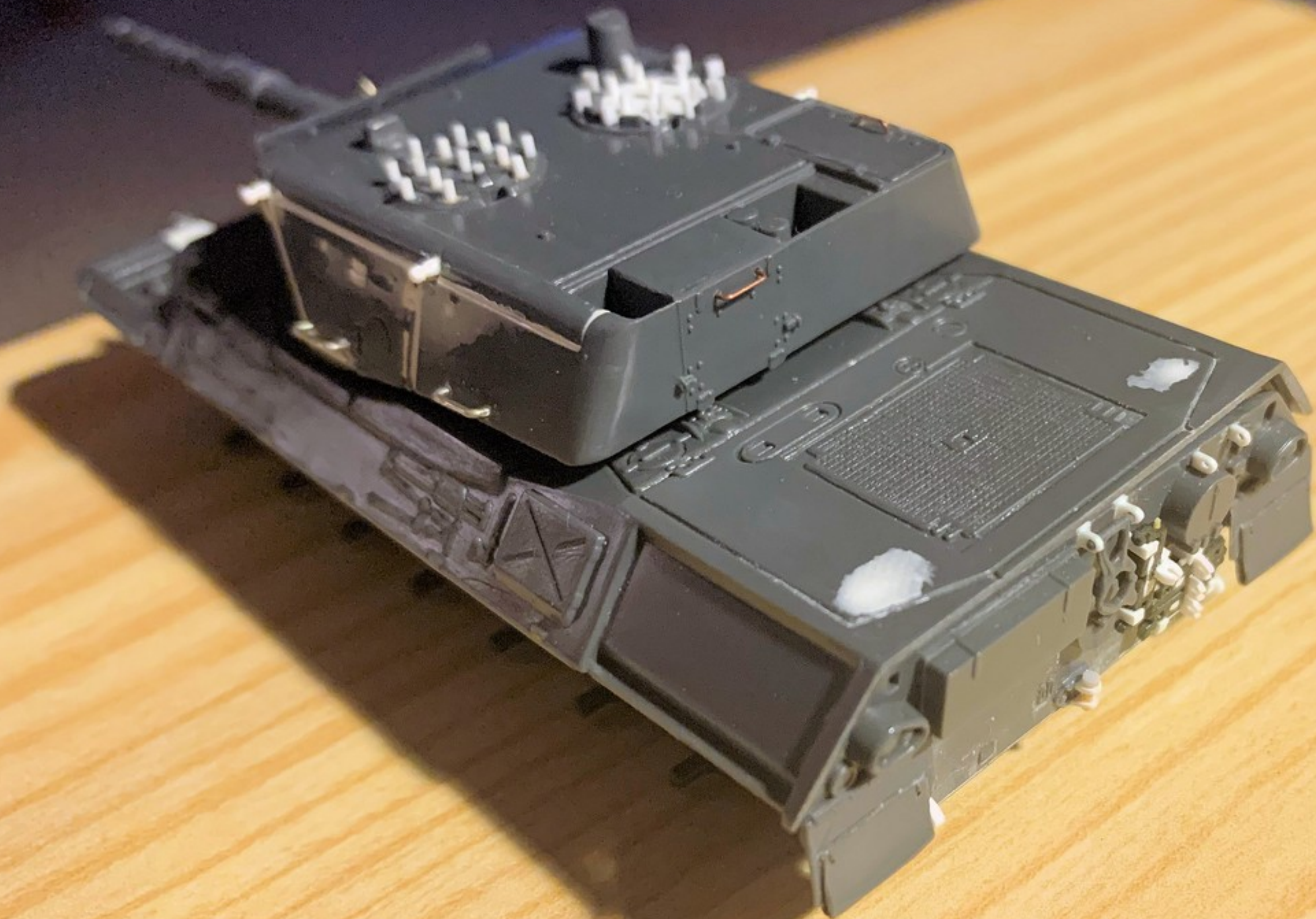


Edit & Cr

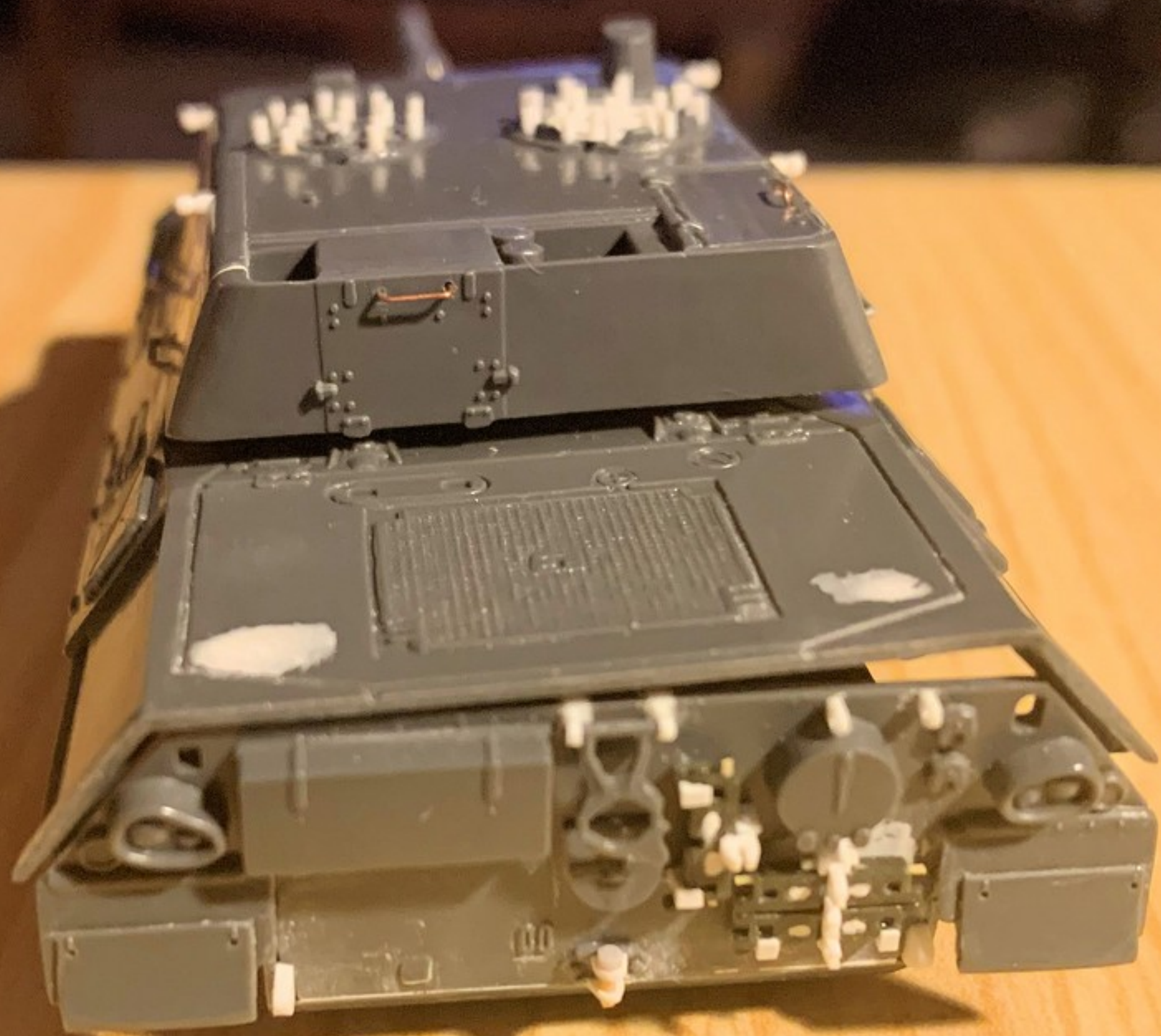


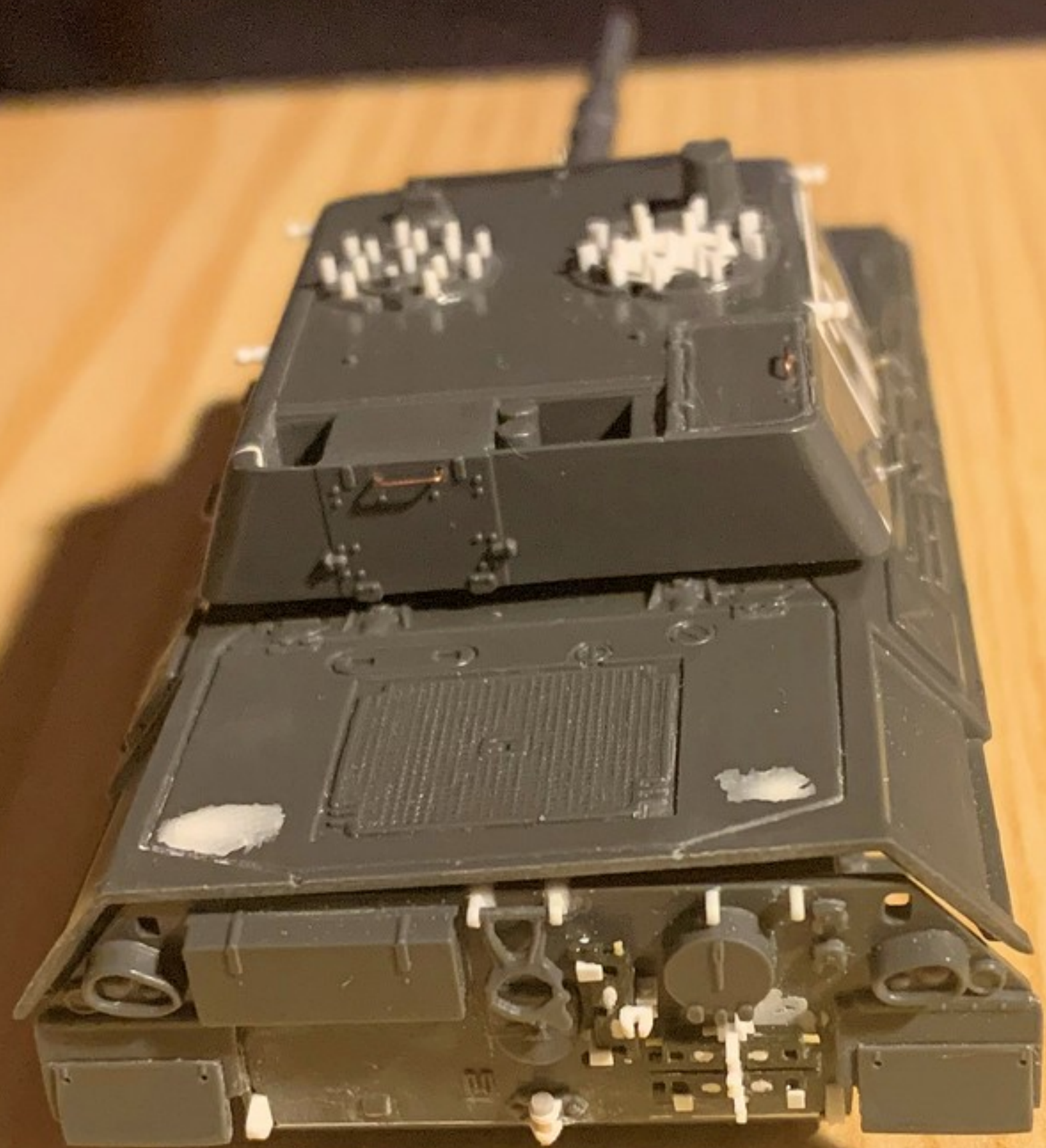












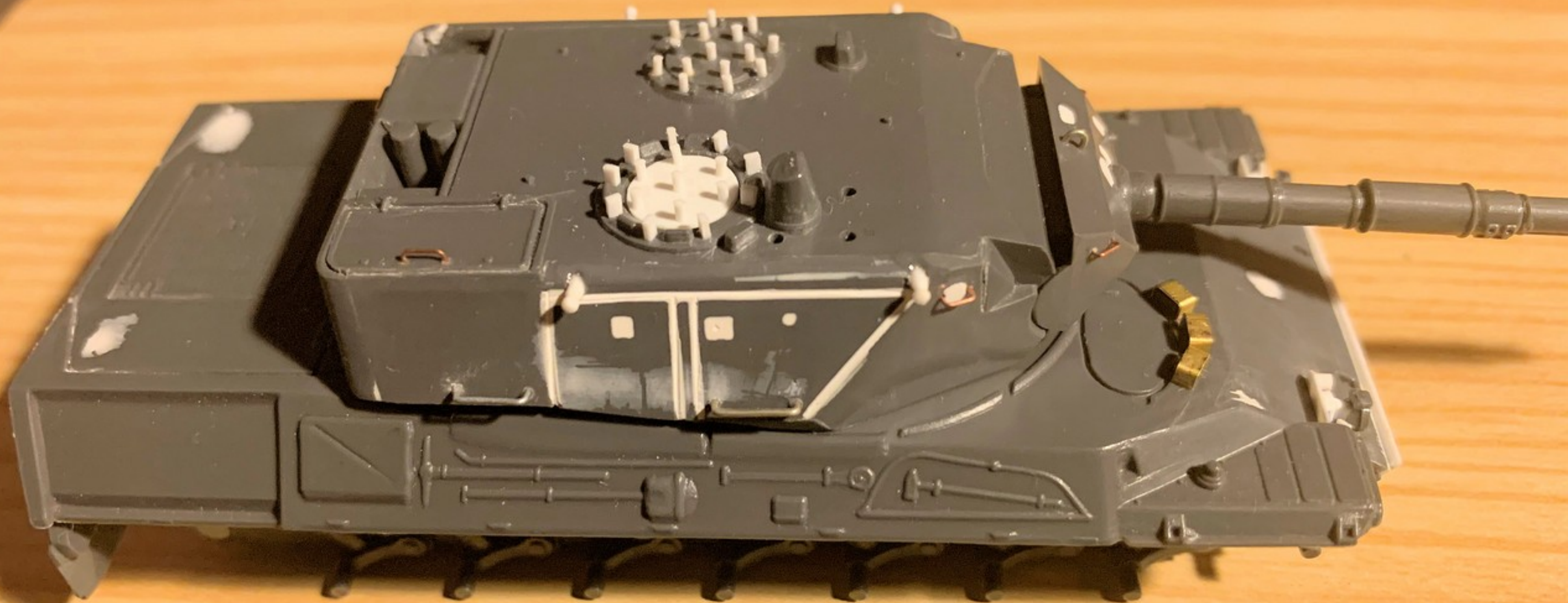






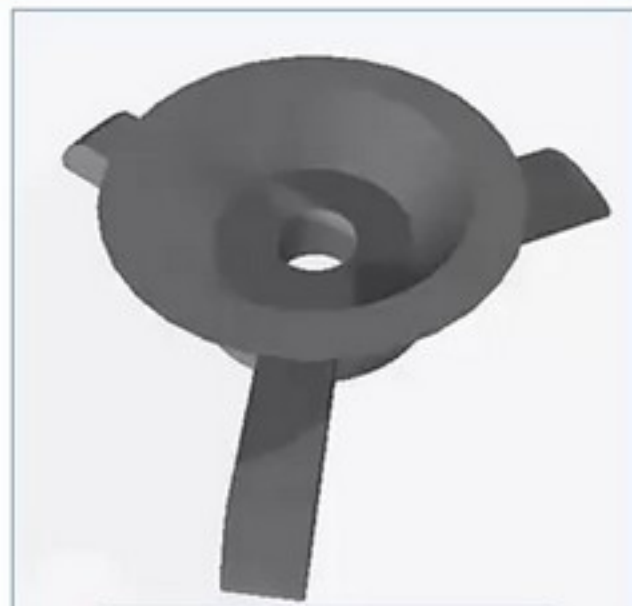
IMAGE FROM THE WEB







Valve Stem with Spring Retainer



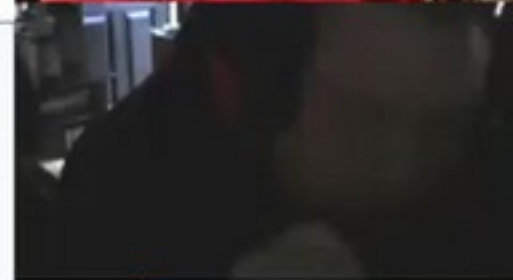
Exhaust Valve Guide and Gas Deflector

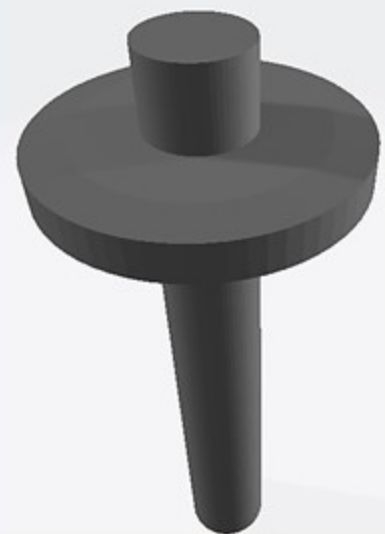


Curved Engine Data Plate for Model

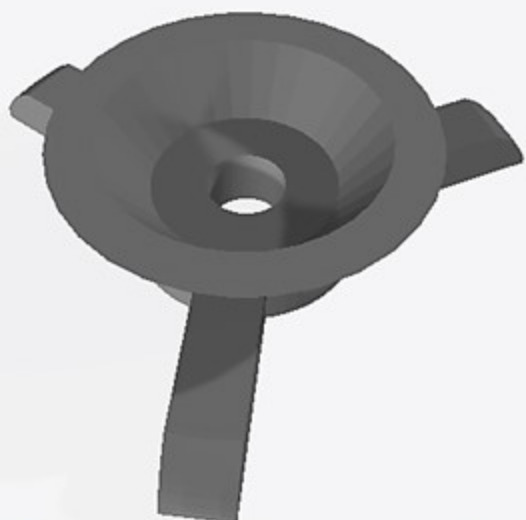


Flat Engine Data Plate for Vignette Base





**Valve Stem
with
Spring Retainer**



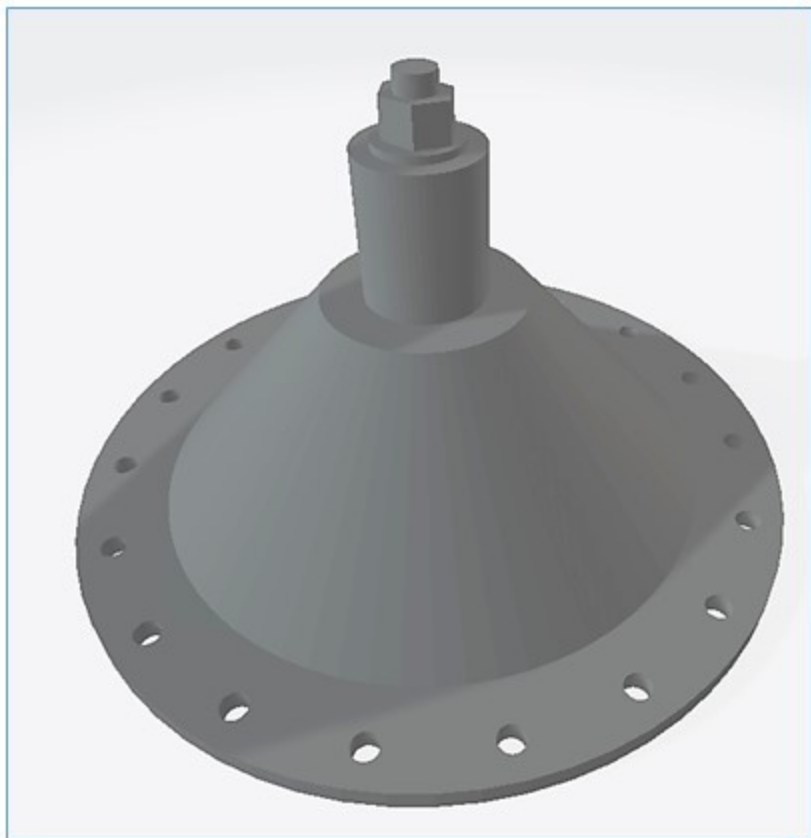
**Exhaust Valve
Guide and Gas
Deflector**



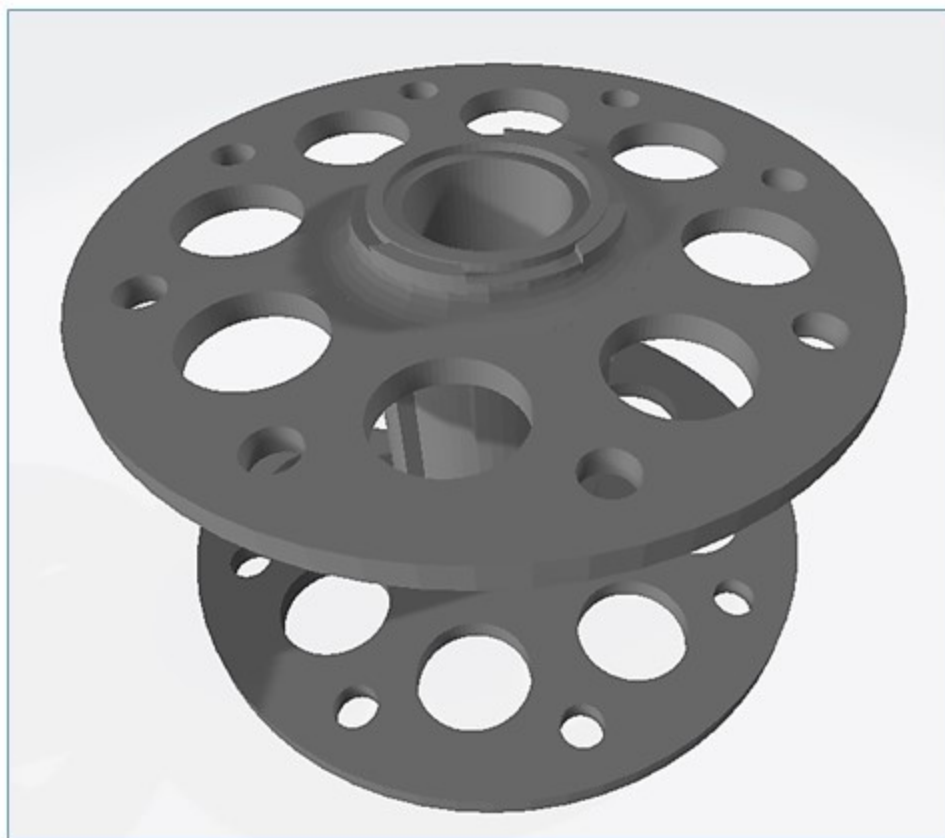
Curved Engine Data Plate for Model

Flat Engine Data Plate for Vignette Base

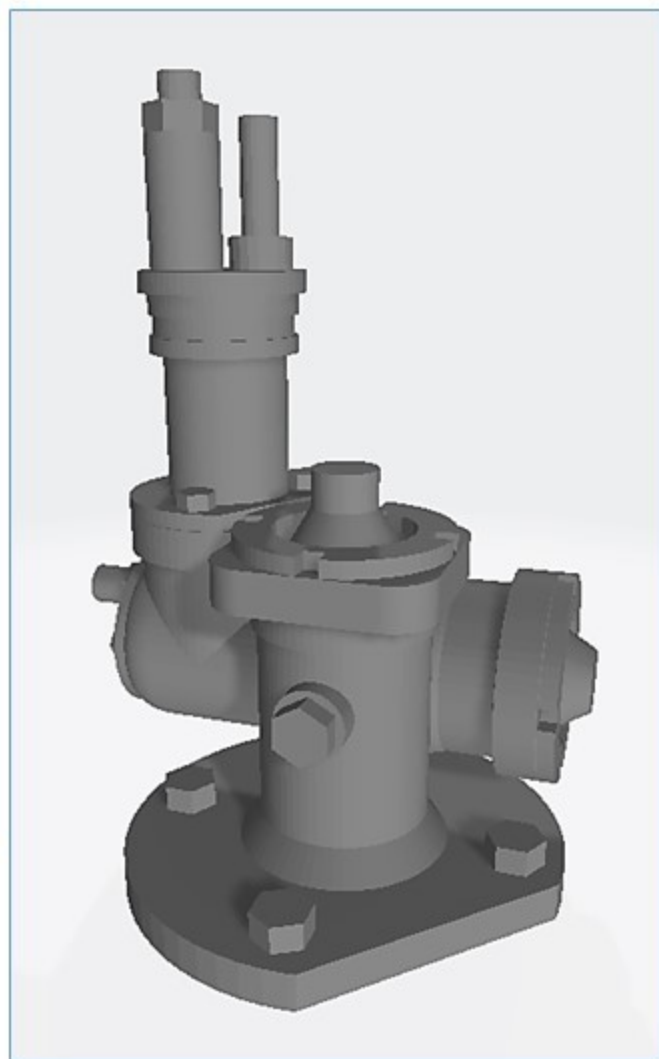




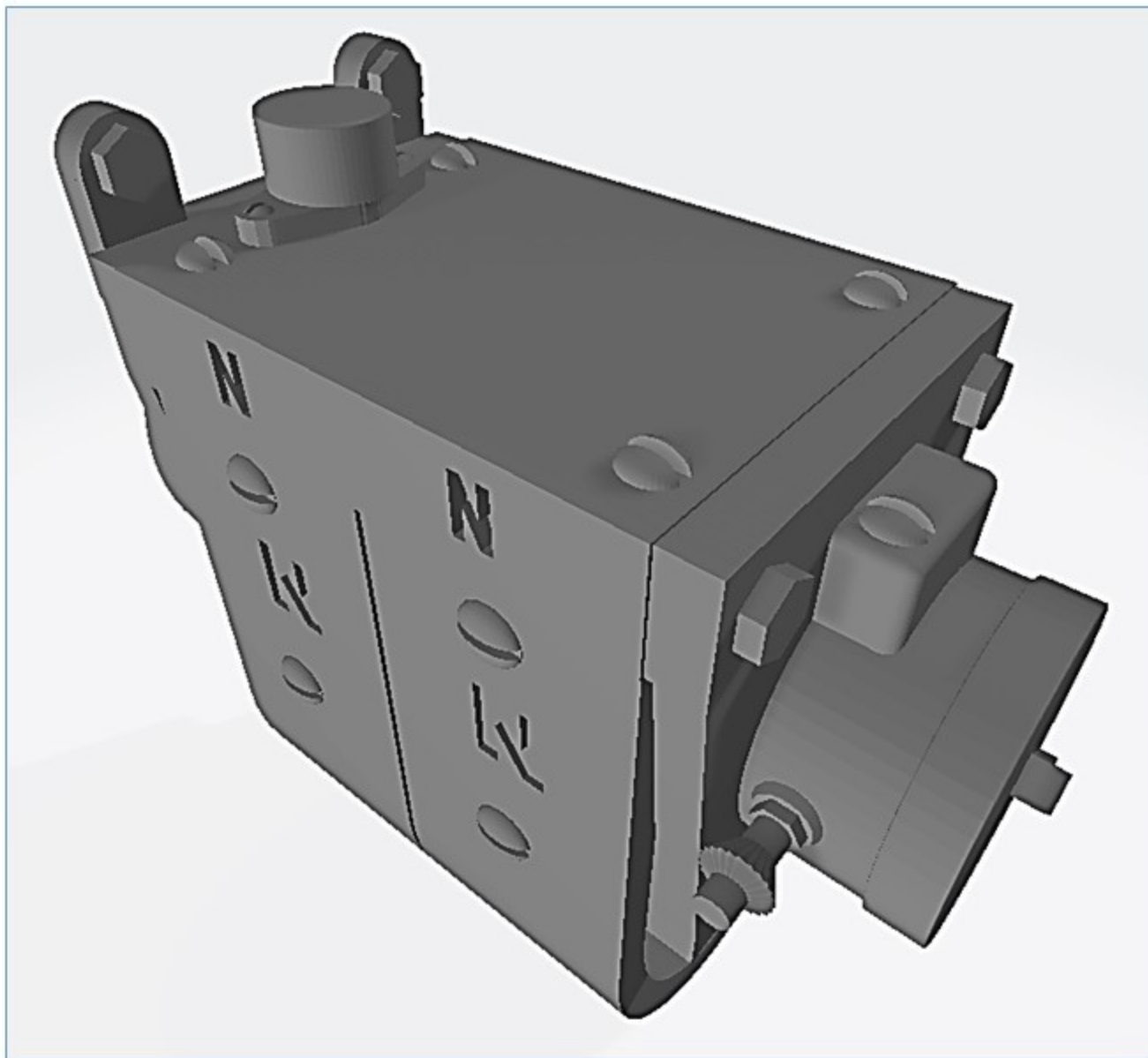
**Crankcase Front Plate
with
Prop Mounting Shaft**



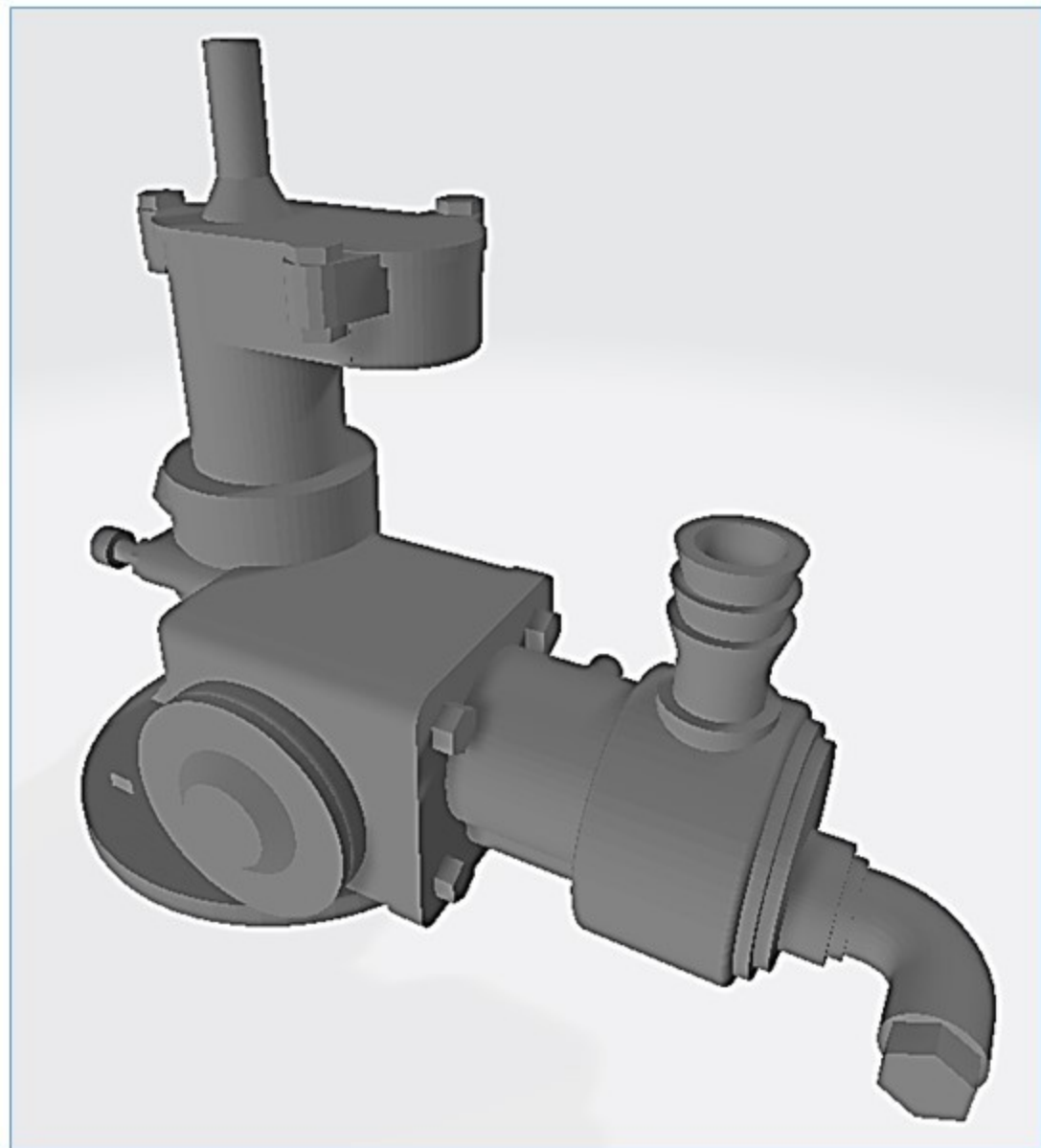
Propeller Hub



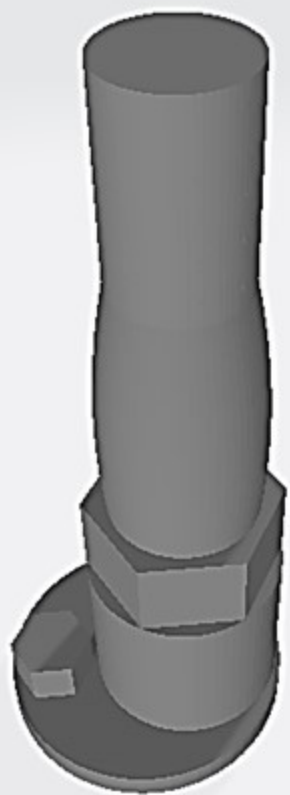
Air Pump



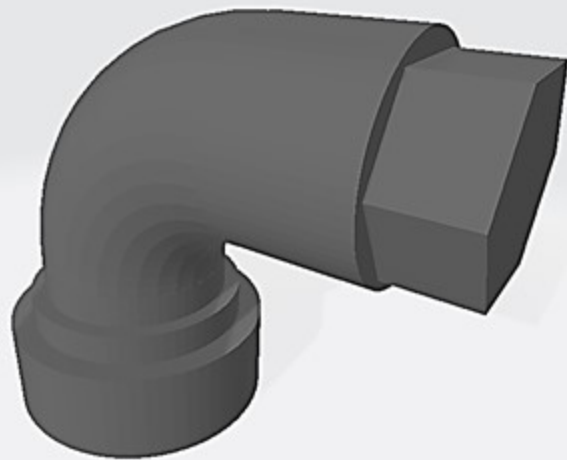
Nilmelior High Tension Direct Ignition Magneto



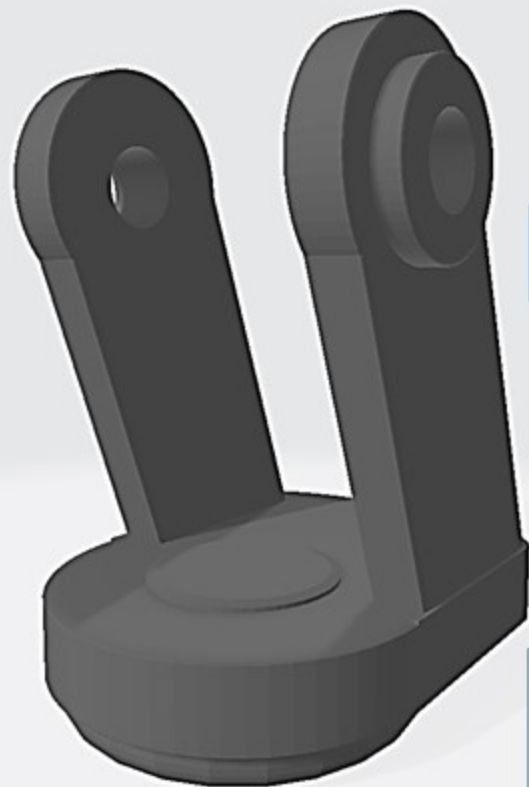
Oil Pump



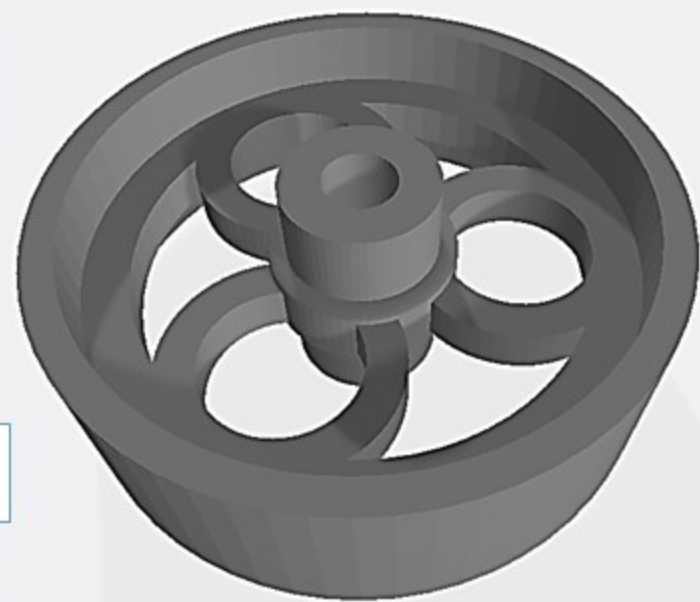
**High Tension
Ignition Wire
Lead**



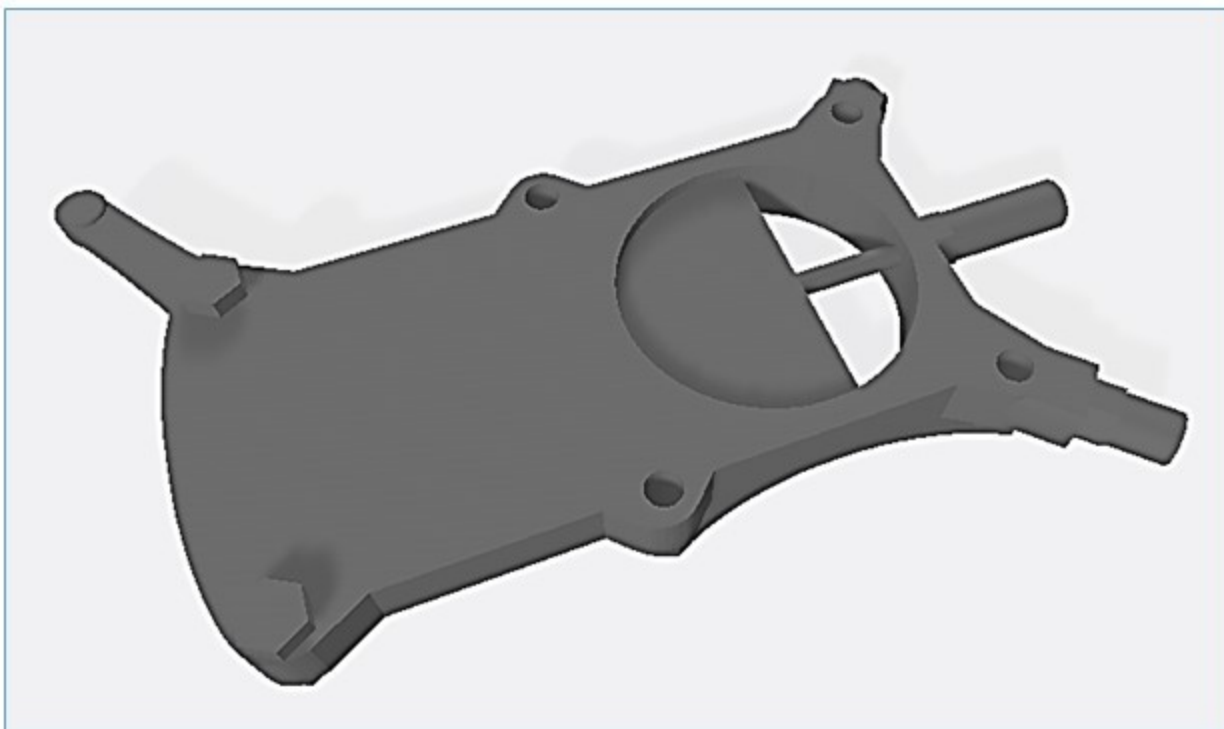
**Oil Line
Connector**



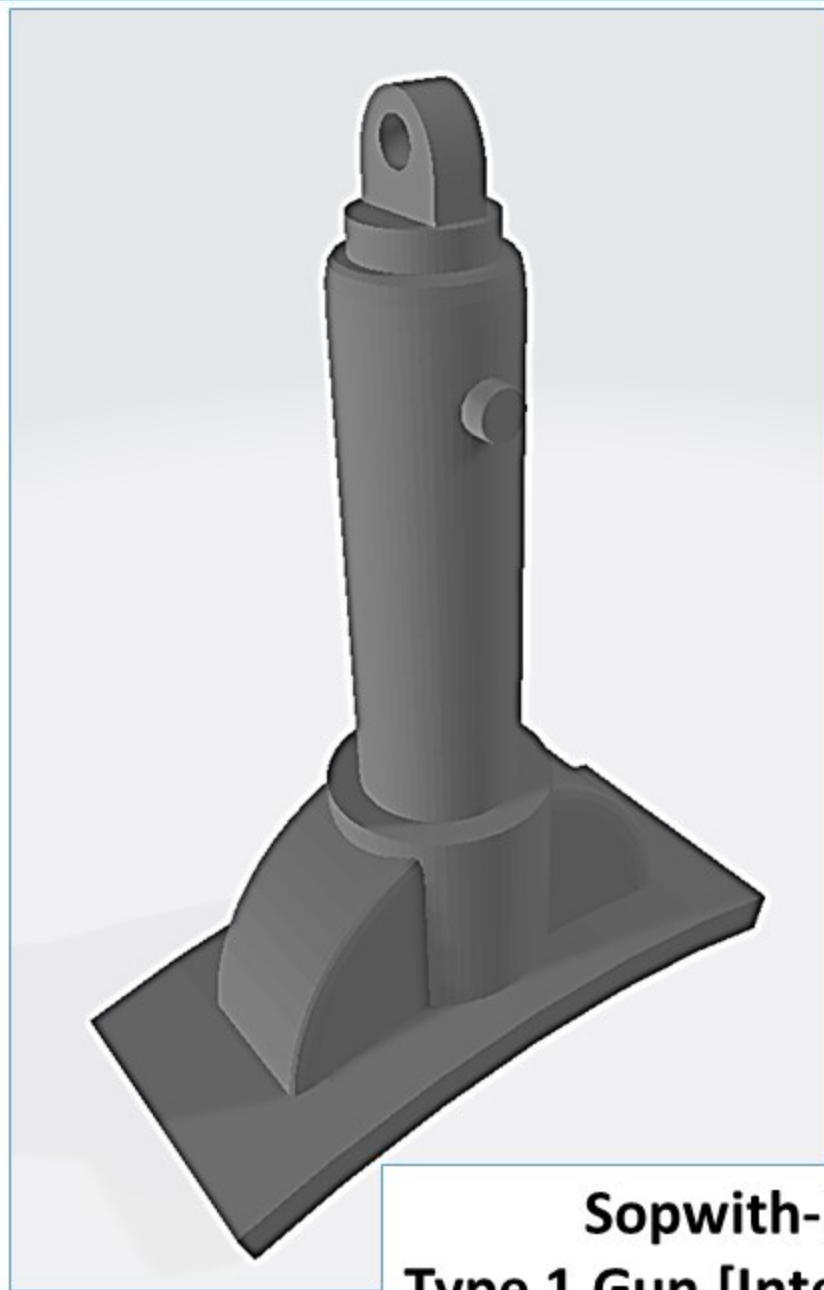
Castor Wheel Mount



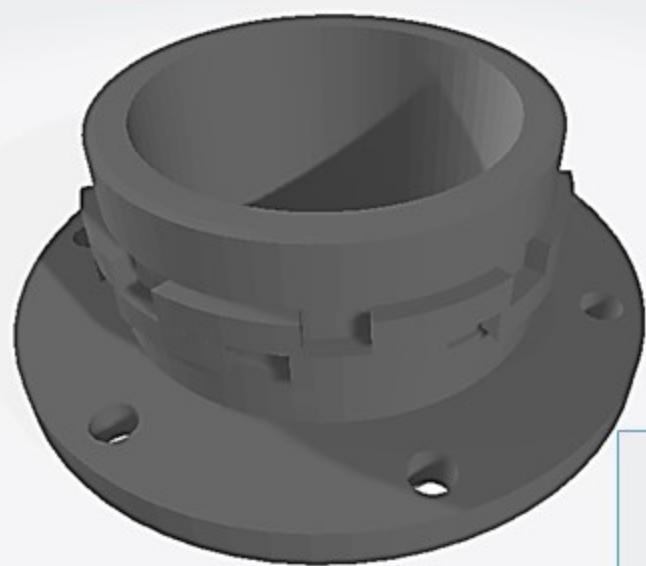
Castor Wheel



**[Rene] Tampier Bloctube
Carburetor**



**Sopwith-Kauper
Type 1 Gun [Interrupter] Gear**



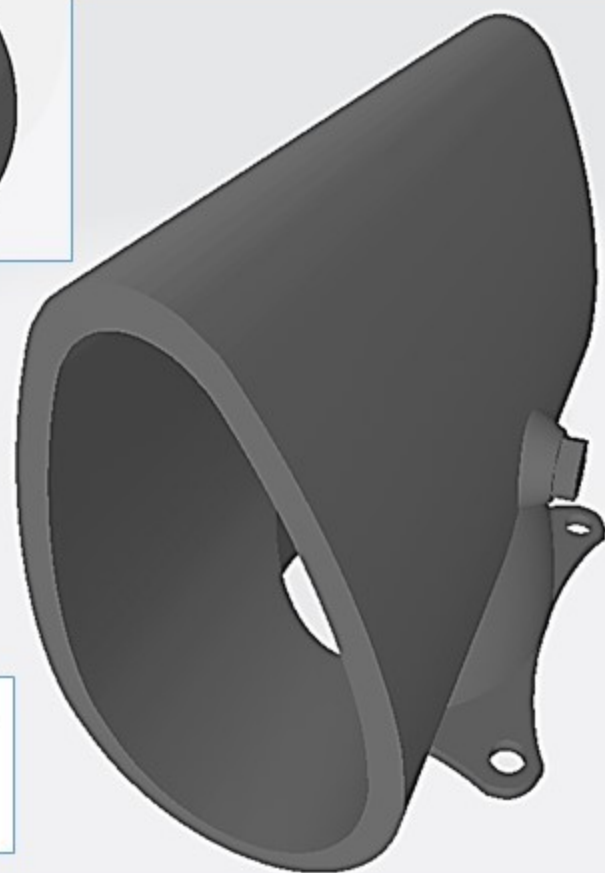
**Carburetor / Engine
Mounting Flange**

**Accessory Case
Engine Shaft
Sleeve**



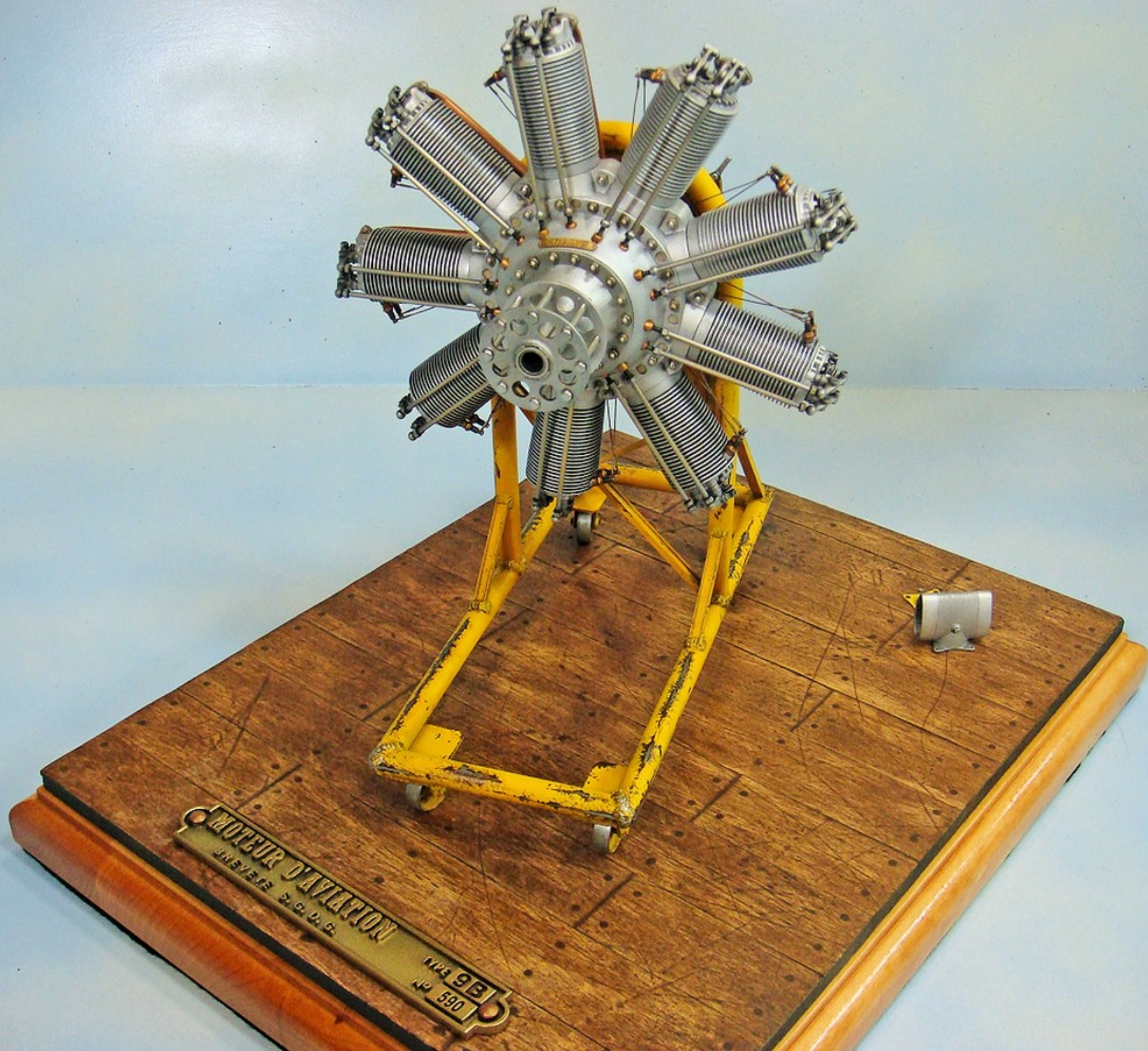
Shaft Sleeve Lock

**Carburetor
Air Intake**

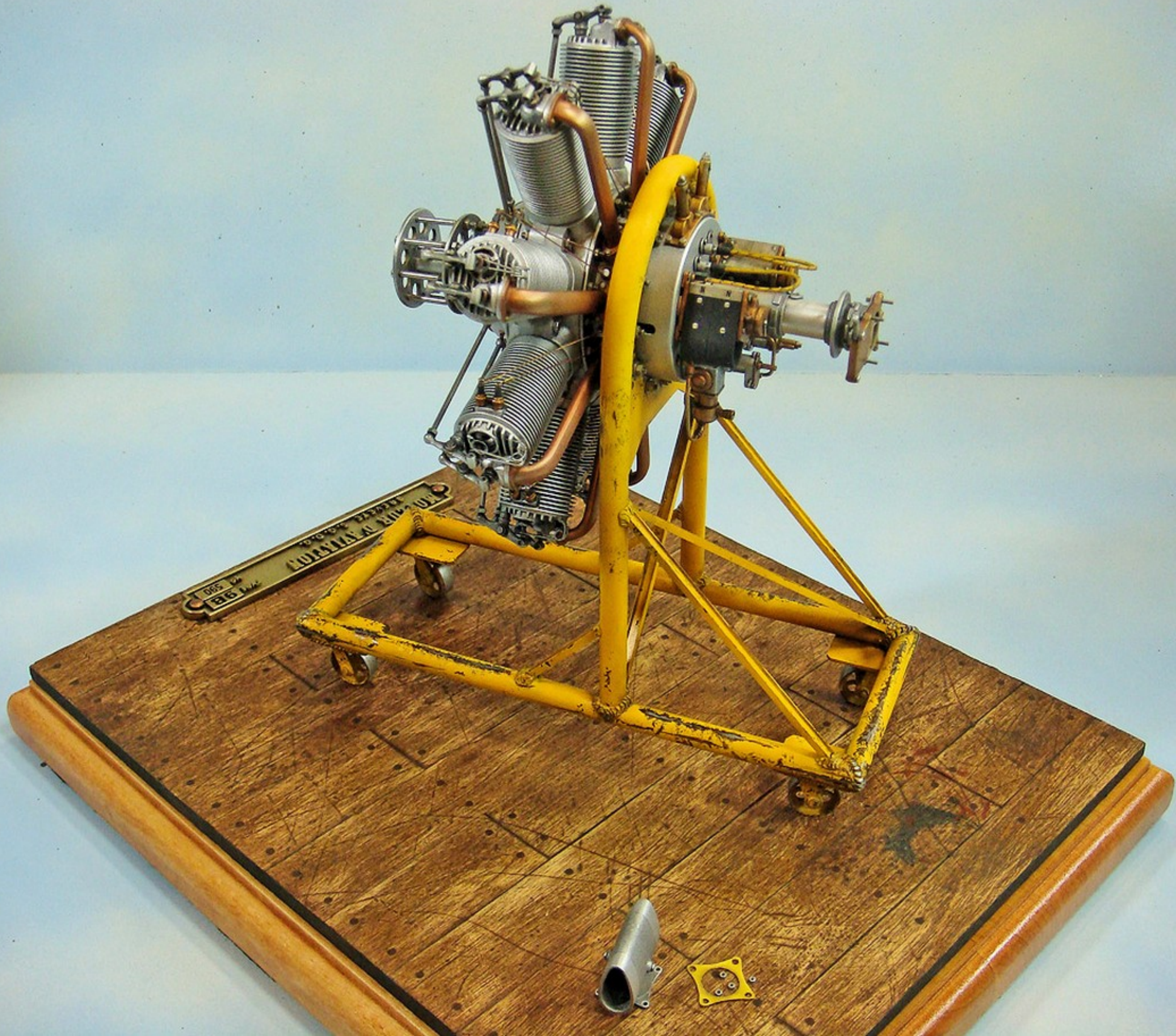


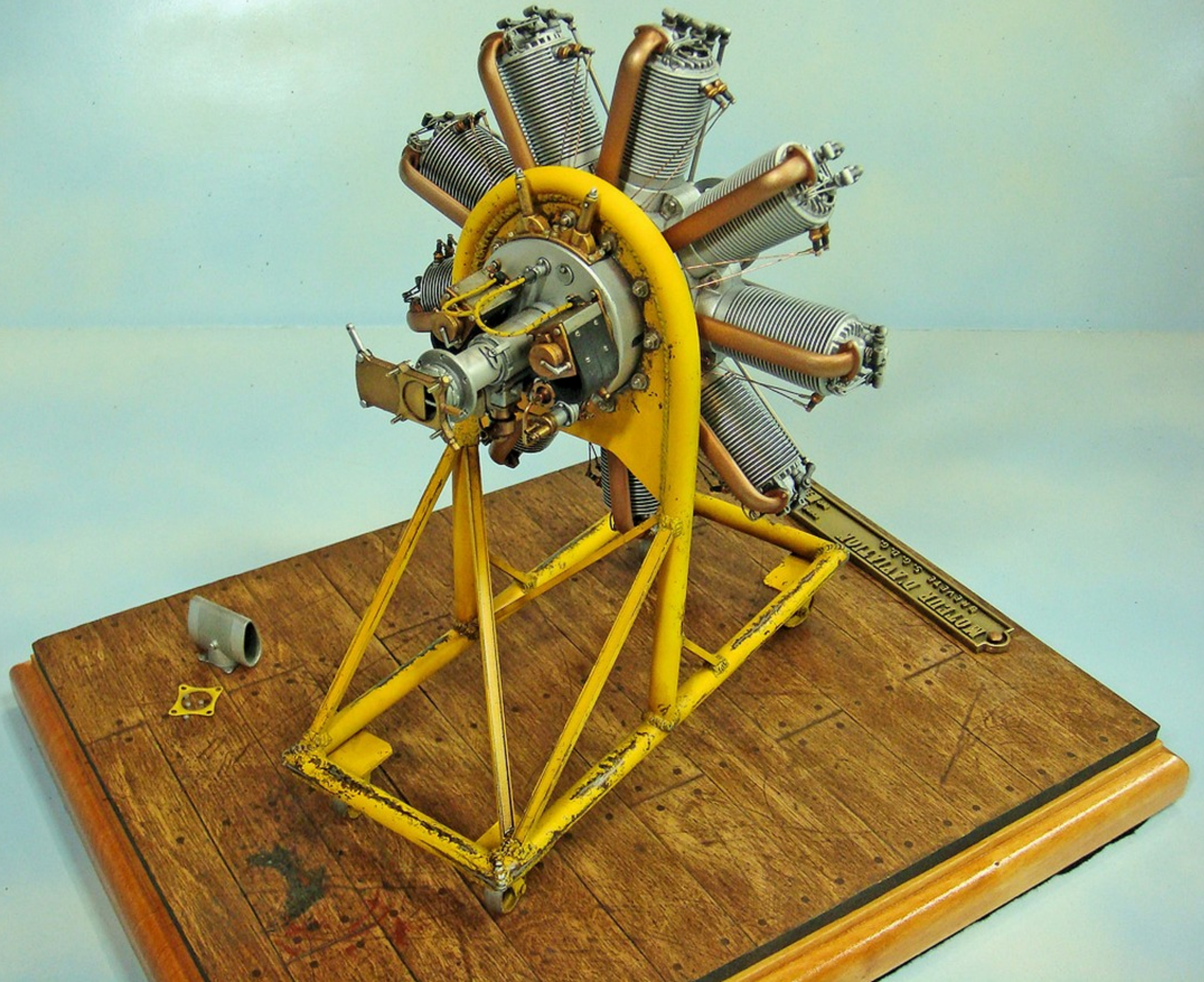


MOTEUR D'AVIATION
BREVETE S.G.D.G.
TYPE 9B
NO 590

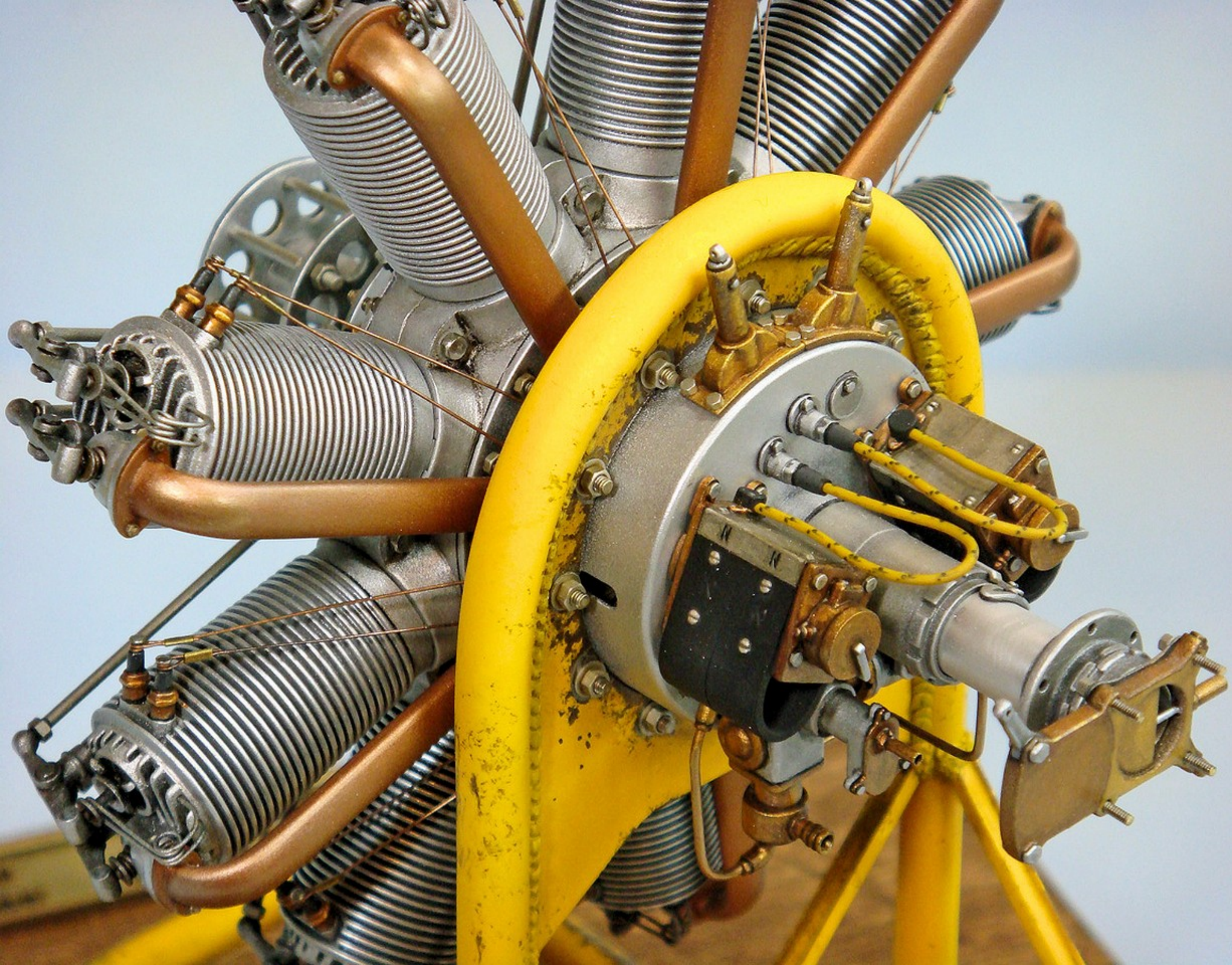


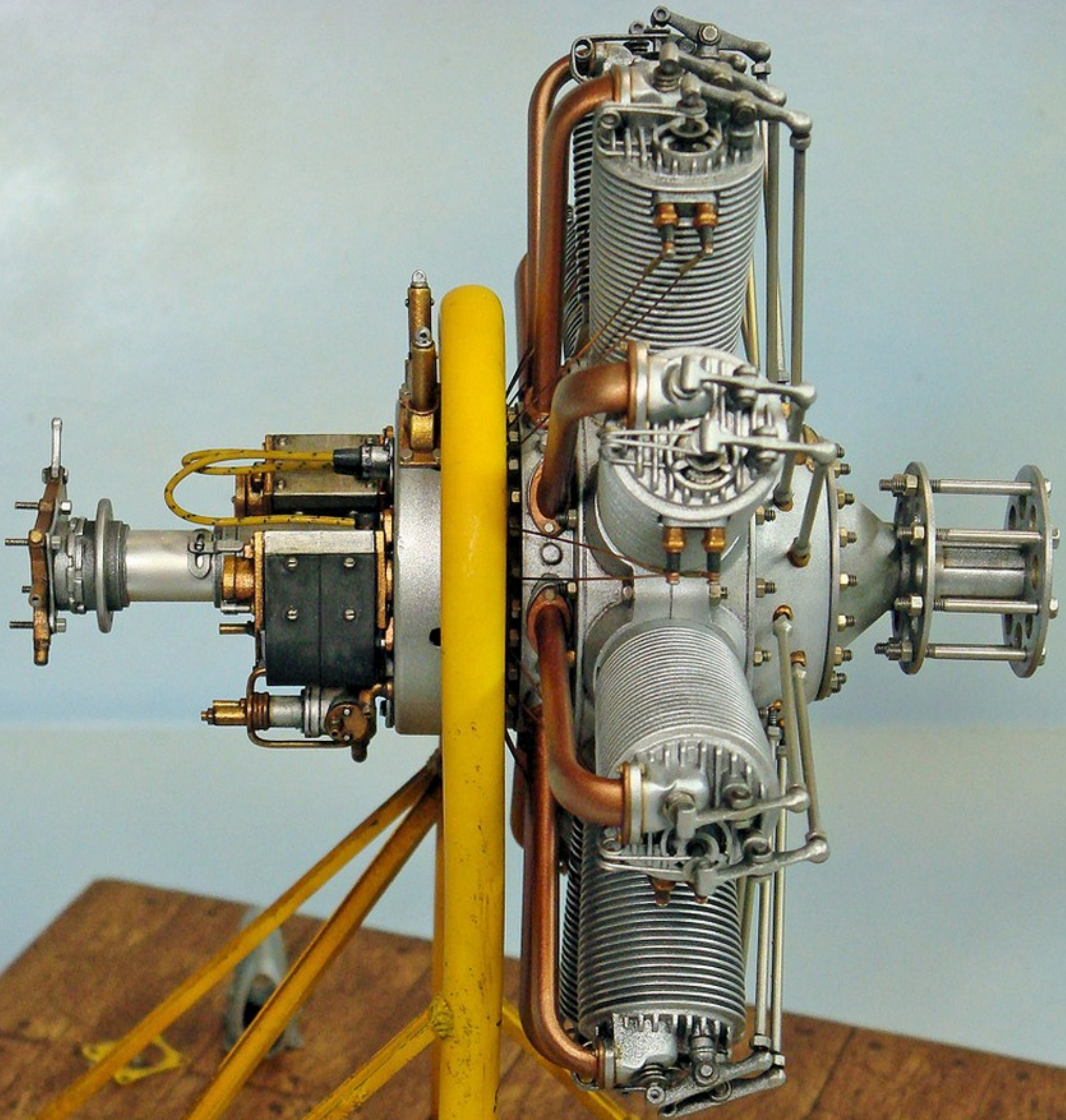
MOTEUR D'AVIATION
UNIVERSITE 21.2.29
TYPE 9B
N° 590

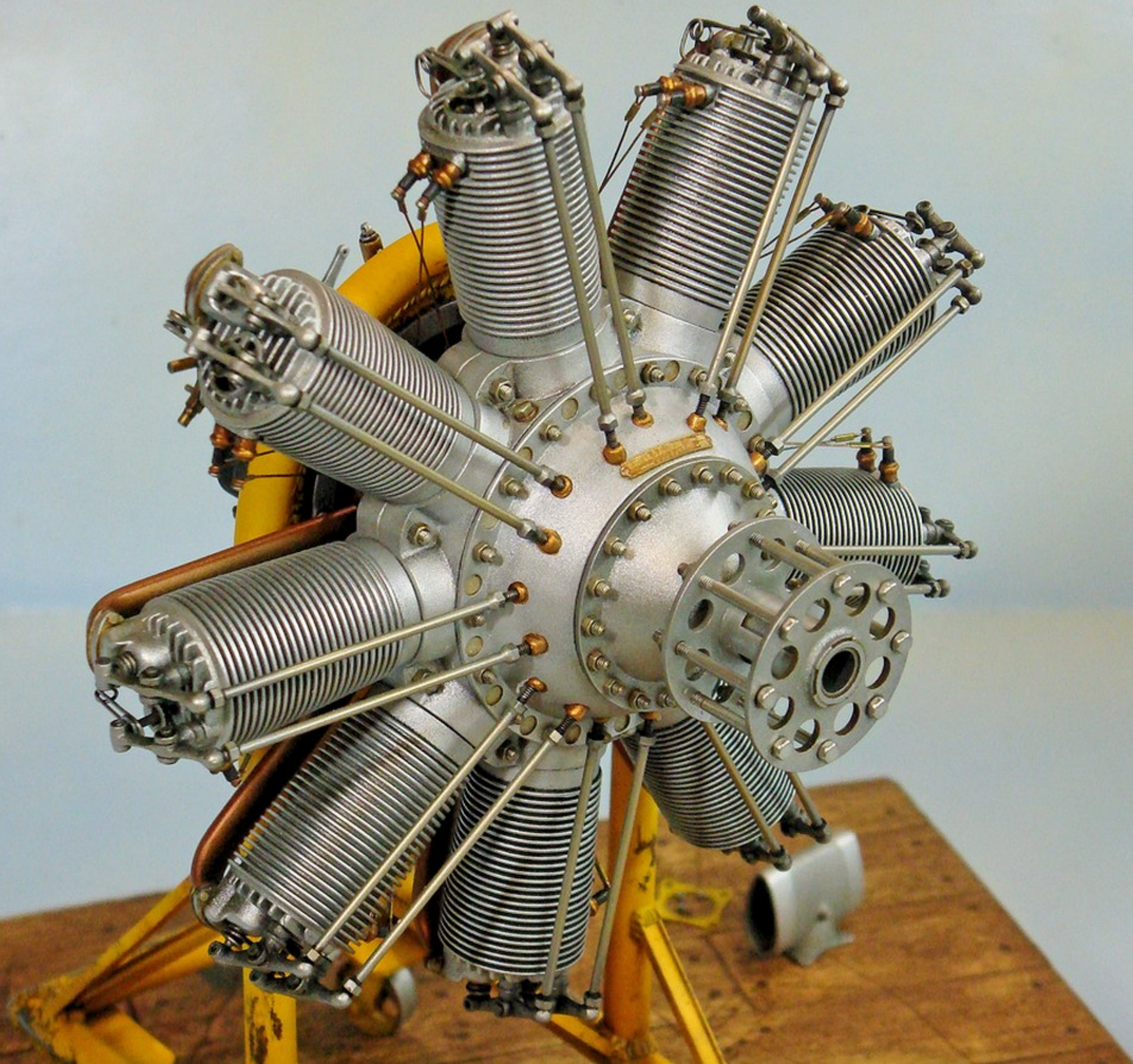


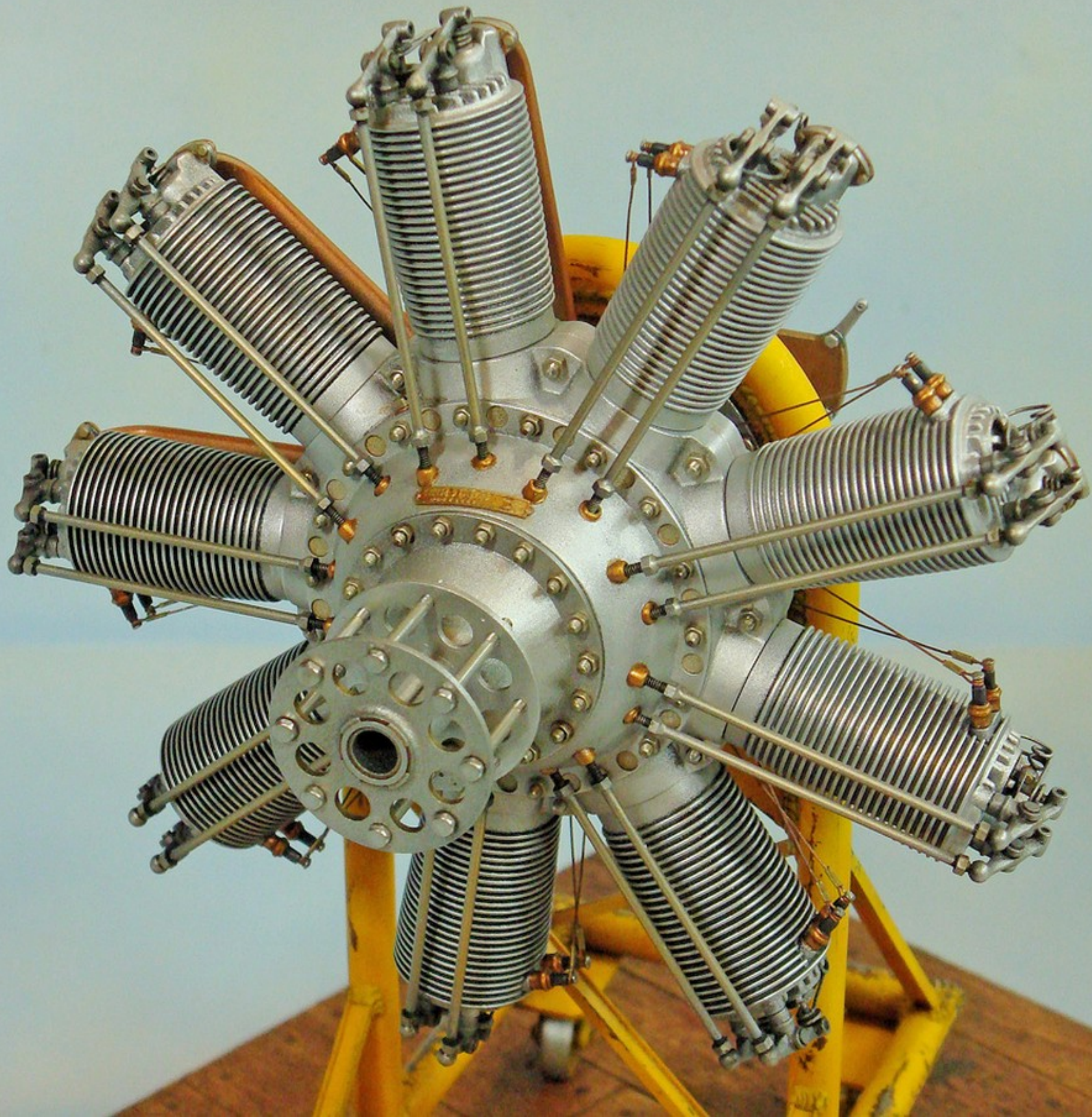


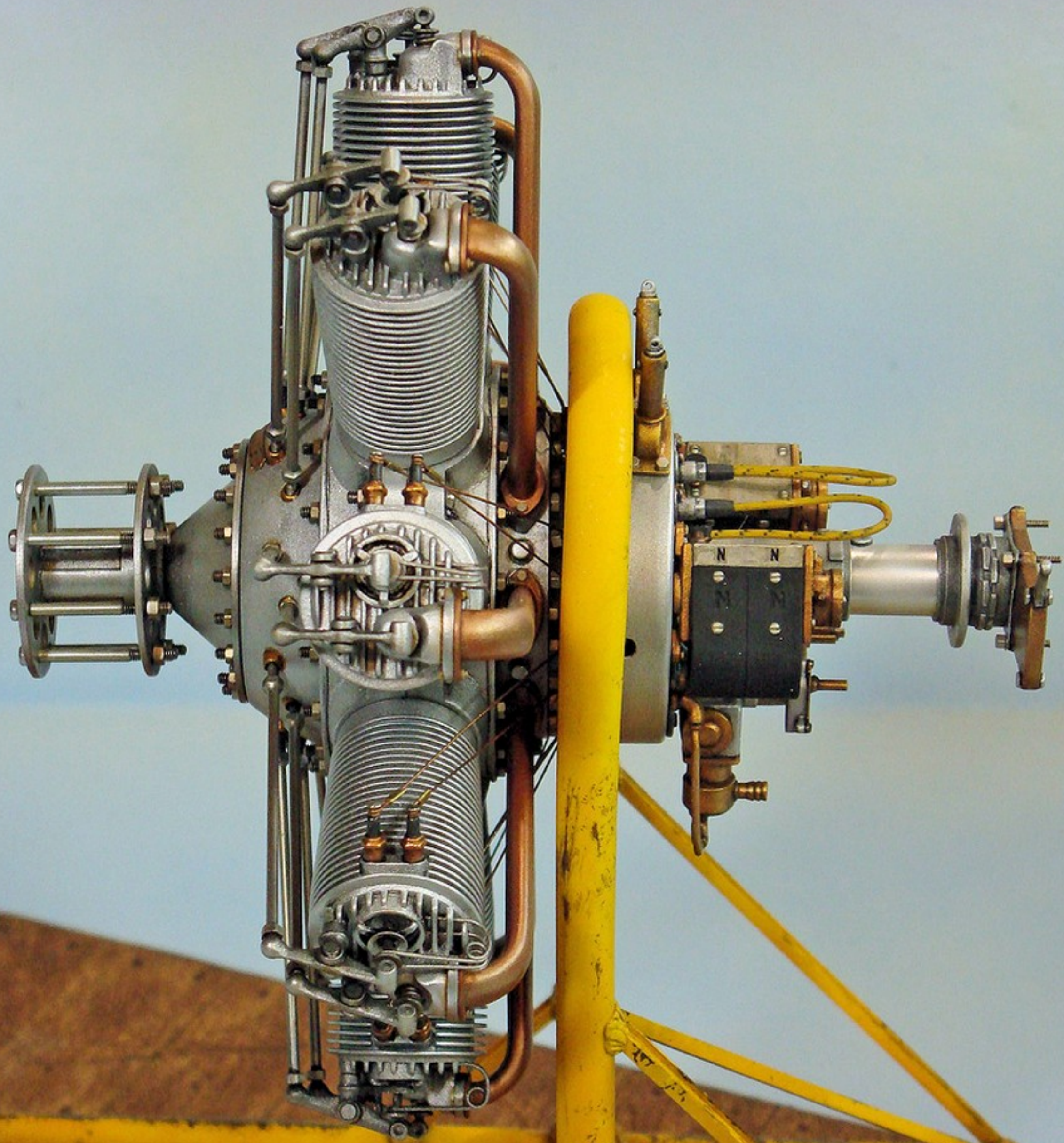


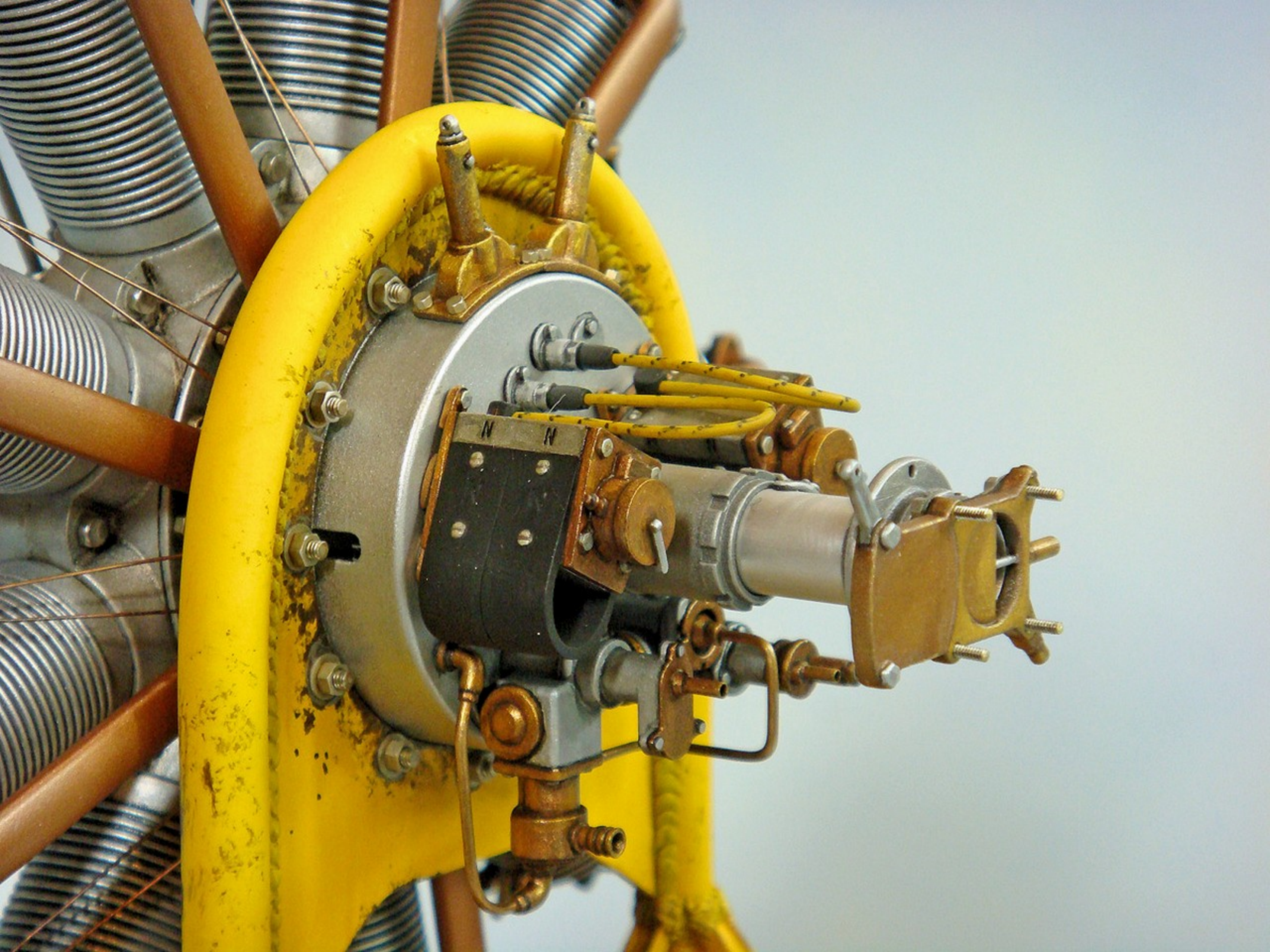


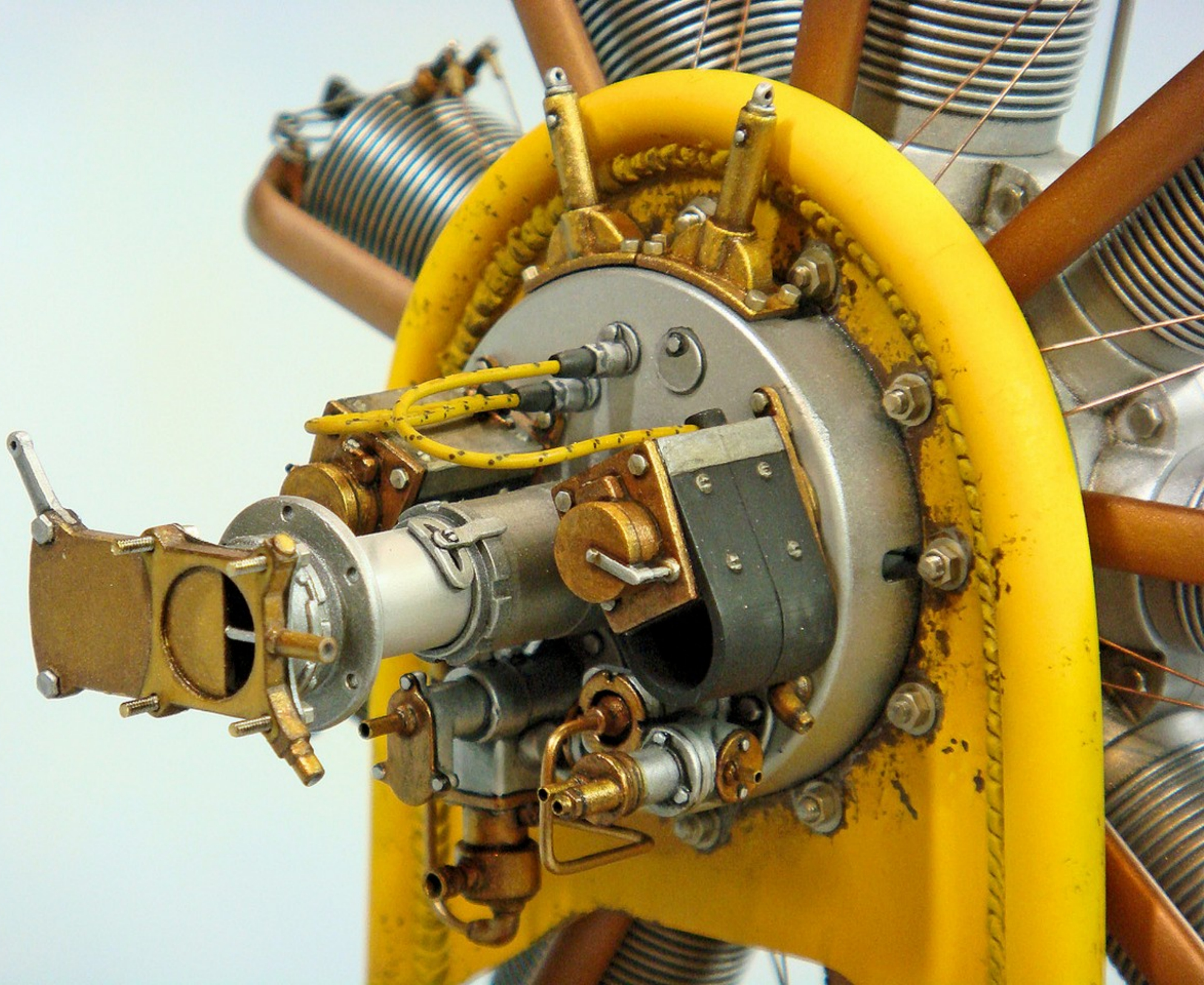
















MOTEUR D'AVIATION

BREVETE S. G. D. G.

TYPE

9B

N°

590





14OCT20 Meeting:

[Virtual meeting using Zoom due to Covid-19; run by Ralph Nardone, with 6 other club members participating.]

1. Pz.Kpfw. IV Ausf. H (Tamiya + Cavalier resin Zimmerit), 1/35 – John Sherrer
2. M51 75mm Anti-Aircraft Gun “*Skysweeper*” (Renwal + scratch-build details), 1/32 – John Sherrer
3. Sturmtiger (Revell/Italeri (molded zimmerit & interior) + headlight power conduit, sheet styrene fillers on the front splash guard & rear engine deck), 1/35 – Dave Cicimurri
4. French VBCI “Afghanistan” (Armored Infantry Fighting Vehicle) (Heller), 1/35 – Dave Cicimurri [no pictures]
5. T-64 BV Mod 1985 Ukraine (Trumpeter + Orange Hobby metal Barrel & Smoke Dischargers), 1/35 – Dave Varettoni [no pictures]
6. Leopard 1 A4 (ESCI + scratch-built details), 1/72 – Jeff Nelson
7. Extreme Patriot AB (Badger), 1/1 – Matthew Goodman
8. F4J (UK) RAF No. 74 Squadron (Academy + Belly Strap, Eduard “Zoom”? PE), 1/72 – Ralph Nardone
9. French Clerge 9B Engine on Stand (3D Printed parts + scratch-built styrene tubing, angle & sheet), 1/8 – Mike Roof
10. French Mechanic (3D Print), 1/8 – Mike Roof

Raffle: Nope. Nada.