

# RYERSON REALTY LLC

2761 Country Lane Circle  
Eagle Grove, IA 50533-0877

Phone 515-448-3079

Fax 515-448-5028

ryerson@goldfieldaccess.net

www.ryersonauctionrealtyltd.com



**Deborah D Vance, Broker**  
515-689-3715

**Michael Ryerson, Sales**  
515-689-3728

**Todd Swalin, Sales**  
515-851-1843

**Price:** \$200,000  
**Property Location:** 802 N Main St  
Goldfield, IA 50542  
North on Main street to  
Rail Road track, on West  
side of road

**Terms of Sale:** Cash  
**Possession:** Upon Final Settlement  
**Net Taxes:** \$2398 2022/2023  
**Close Date:** 2023

**Approximate Age:** 2005 120'X54' Machine Shed  
1989 80'X40' Heated Shop  
1970 20'X22' Garage  
1965 30'X24' Office

**1.95 Acres Green Grass**

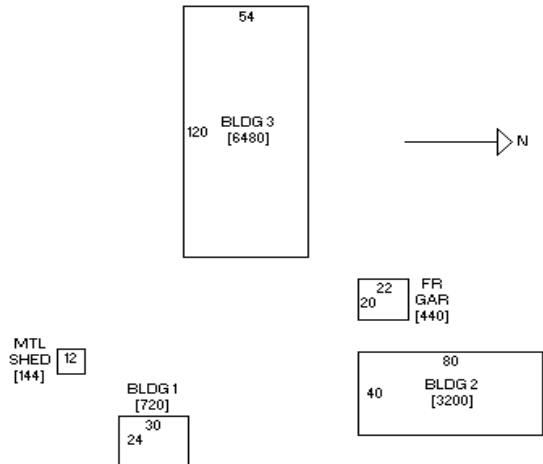

The following information, although believed to be accurate, is not guaranteed to be so. Buyer should do his own inspections. We assume no liability. The measurements are estimates only. This info is subject to change without notice. The seller does not warrant appliances past day of listing. The greatest compliment we can receive is a personal referral, please tell your friends about us.