

Compact, machine-mountable mist collectors dedicated for use on combined machine operations.

- Three stage filtration for high filtration efficiency and optimum filter life
- Handles mist, smoke, and particulate applications up to 1200 cfm (2038 m<sup>3</sup>/h)
- Standard Minihelic® gauge indicates when filter maintenance is required
- Hinged access doors makes filter changeout easy and simple
- Provides a cleaner work environment for maximum productivity
- Helps support OSHA Clean Air Standards
- Optional HEPA filter is available on all models

Designed to filter contaminants from machining operations and industrial processes.

- CNC machining
- Grinding
- Turning
- Milling
- Drilling operations



**MM 1200**  
with Optional HEPA

**MM 1200**  
with Optional Junction Box

## STANDARD FEATURES & AVAILABLE OPTIONS

STANDARD	OPTIONAL
Three-stage filtration	Inlet hose kit
Direct-drive fans — ½, 1, and 1½ hp	High efficiency first-stage filter (MM 1200 only)
Hinged access door	P-Trap (MM 1200 only)
High-loft, fine-fiber primary filter	Inlet plenum (MM 1200 only)
10-year warranty	Support legs (MM 1200 only)

## DIMENSIONS & SPECIFICATIONS

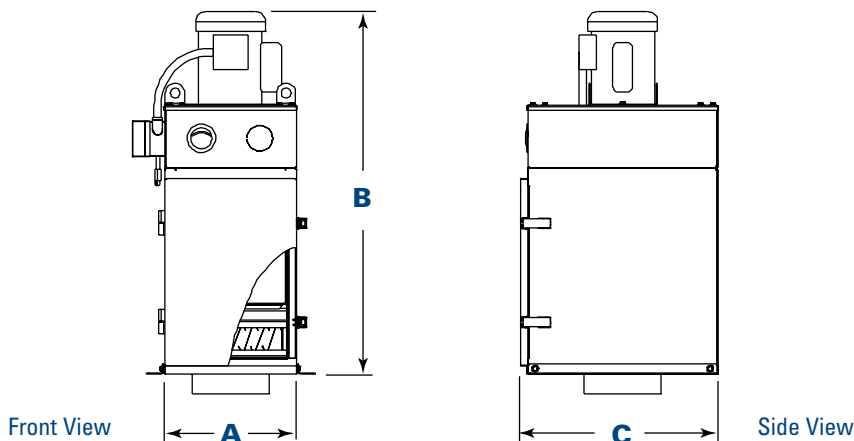

Model	Description	Nominal Airflow*		1st Stage	2nd Stage	3rd Stage	Inlet Collars	Dimensions						Shipping Weight	
		cfm	m³/h					A		B		C		lb	kg
								in	mm	in	mm	in	mm		
MM 500	Machine-mountable, 3-stage filtration, ½ hp power pack	500	24	4" (101.6 mm) aluminum impinger	1" (25.4 mm) aluminum mesh	95% high-loft glass fiber filter	6" (152.4 mm), 8" (203.2 mm)	13.5	342.9	39.2	995.7	20.3	515.6	95	43.1
MM 500 with HEPA option	Machine-mountable, 3-stage filtration plus HEPA filter, ½ hp power pack	300	14	4" (101.6 mm) aluminum impinger	1" (25.4 mm) aluminum mesh	95% high-loft glass fiber filter	6" (152.4 mm), 8" (203.2 mm)	13.5	342.9	49.7	1262.4	20.3	515.6	120	54.4
MM 1200 1 hp	Machine-mountable, 3-stage filtration, 1 hp power pack	1000	48	4" (101.6 mm) aluminum impinger	1" (25.4 mm) aluminum mesh	95% high-loft glass fiber filter	6" (152.4 mm), 8" (203.2 mm), 10" (254.0 mm)	25.5	647.7	41.4	1051.6	24.3	617.2	285	129.3
MM 1200 1 hp with HEPA option	Machine-mountable, 3-stage filtration plus HEPA filter, 1 hp power pack	800	39	4" (101.6 mm) aluminum impinger	1" (25.4 mm) aluminum mesh	95% high-loft glass fiber filter	6" (152.4 mm), 8" (203.2 mm), 10" (254.0 mm)	25.5	647.7	54.7	1389.4	24.3	617.2	350	158.8
MM 1200 1½ hp	Machine-mountable, 3-stage filtration, 1½ hp power pack	1200	58	4" (101.6 mm) aluminum impinger	1" (25.4 mm) aluminum mesh	95% high-loft glass fiber filter	6" (152.4 mm), 8" (203.2 mm), 10" (254.0 mm)	25.5	647.7	41.4	1051.6	24.3	617.2	290	131.5
MM 1200 1½ hp with HEPA option	Machine-mountable, 3-stage filtration plus HEPA filter, 1½ hp power pack	950	46	4" (101.6 mm) aluminum impinger	1" (25.4 mm) aluminum mesh	95% high-loft glass fiber filter	6" (152.4 mm), 8" (203.2 mm), 10" (254.0 mm)	25.5	647.7	54.7	1389.4	25.3	642.6	355	161.0

\* Based on clean filters.

Significantly improve the performance of your collector with genuine Donaldson Torit replacement filters and parts. **Call Donaldson Torit today 800-365-1331.**



Tel 800-365-1331 (USA)  
Tel 800-343-3639 (within Mexico)

donaldsontorit@donaldson.com  
donaldsontorit.com

Donaldson Company, Inc.  
Torit  
P.O. Box 1299  
Minneapolis, MN  
55440-1299 U.S.A.

**EXACTLY WHAT YOU NEED.™**

Mini-Mist Collector (11/12)

© 2003 Donaldson Co., Inc. All Rights Reserved. All products, product specifications, and data (airflow, capacity, dimensions, or availability) are subject to change without notice, and may vary by region or country. Donaldson Torit is a registered trademark of Donaldson Company, Inc. Contains Donaldson proprietary technology.