

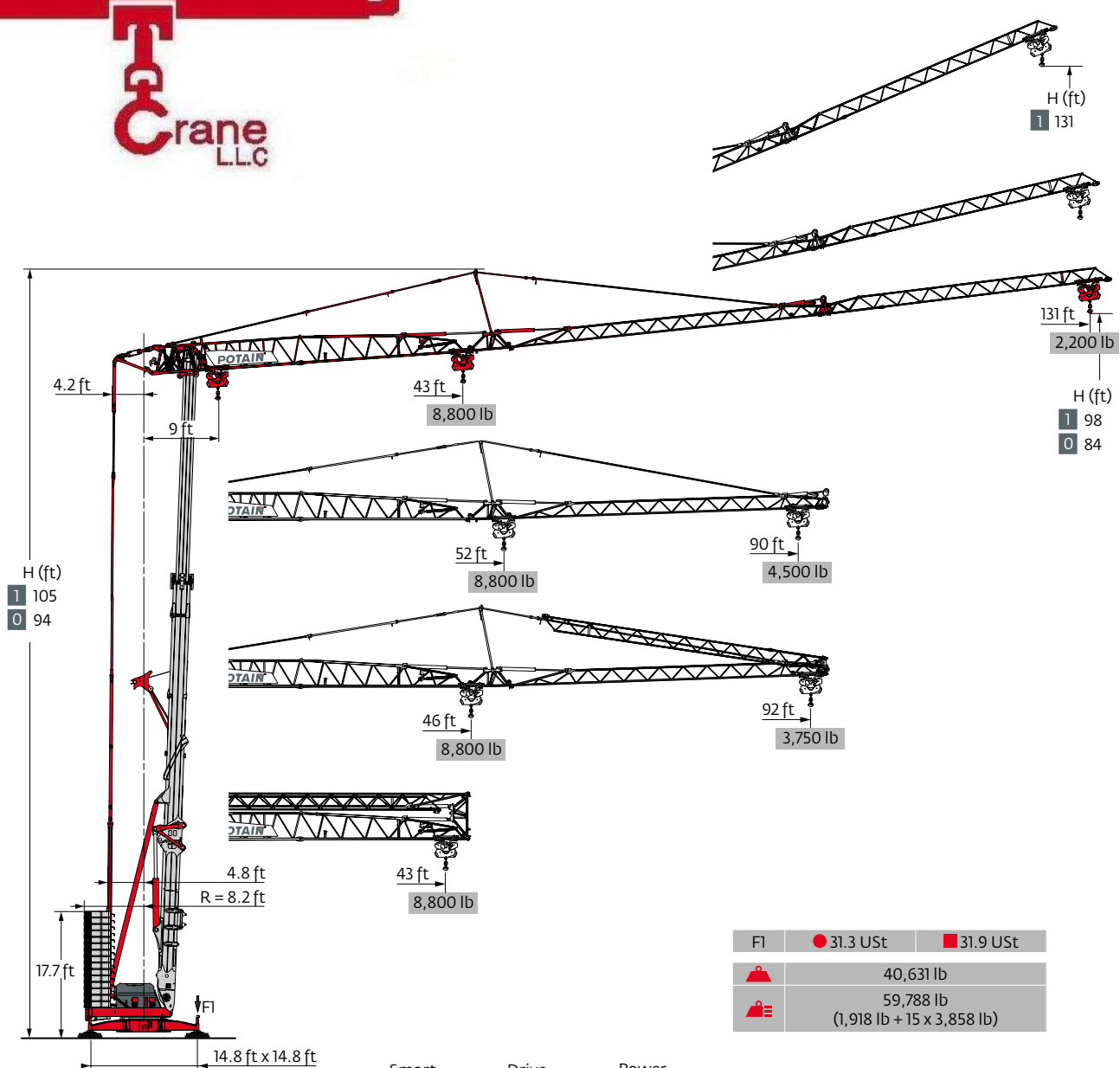

Hup 40-30



Smart Set-up

Drive Control

Power Control

CraneSTAR® Diag

Top Site

Top Tracing 3

Load curves

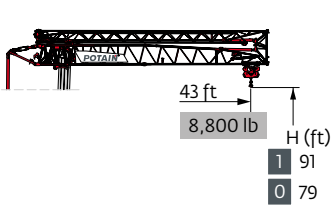

131 ft	9	▶	43	ft
▲▲▲	▲		8,800	lb
90 ft	9	▶	43	ft
▲▲▲	▲		8,800	lb

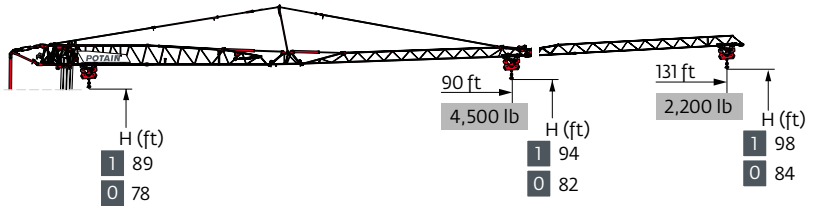

9	▶	43	46	49	52	56	59	62	66	72	82	89	98	105	115	121	131	ft	
																			lb
9	▶				52	56	59	62	66	72	82	90							ft
																			lb

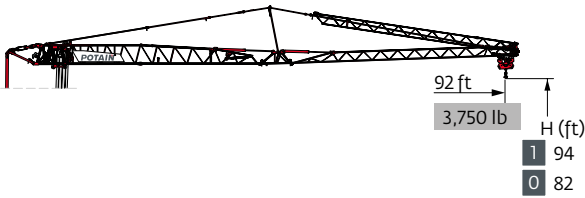

131 ft	9	▶	46	49	52	56	59	62	66	72	82	89	92	ft
▲▲▲	▲		8,800	8,050	7,450	6,900	6,450	6,050	5,650	5,050	4,300	3,900	3,750	lb

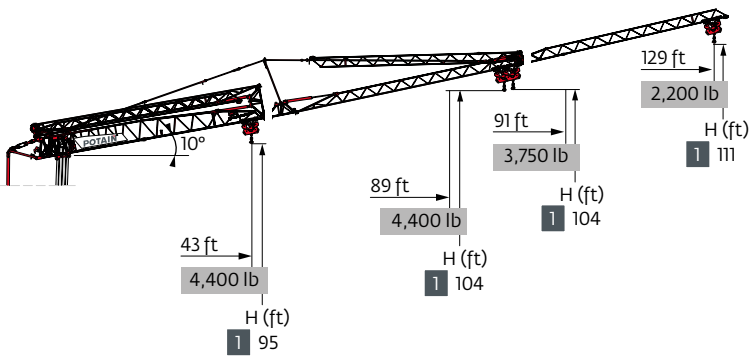

131 ft	9	▶	75	82	89	98	105	115	121	129	ft
▲▲▲	▲		4,400	3,900	3,550	3,100	2,850	2,550	2,400	2,200	lb
90 ft	9	▶			89						ft
▲▲▲	▲				4,400						lb
131 ft	9	▶	80	82	89	91					ft
▲▲▲	▲		4,400	4,250	3,850	3,750					lb
131-90 ft	9	▶	43								ft
▲▲▲	▲		4,400								lb

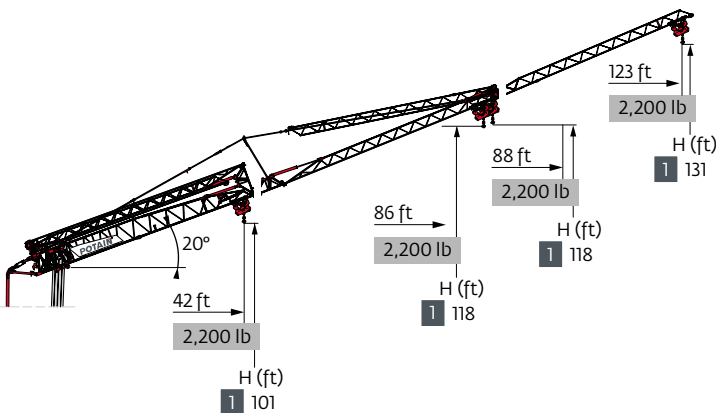

Hup 40-30

Mechanisms

480 V - 60 Hz								hp	kW
	18 HPL 10	fpm	6	62	118	190	213	18	13
		lb	8,800	8,800	4,400	2,200	1,100		
	3 DVF 5	fpm	3 → 148 (0 → 2,200 lb) 3 → 135 (2,200 lb → 8,800 lb)					3	2.2
	HPS 142	rpm	0 → 0.9					2 x 5	2 x 3.7

IEC 60204-32	kVA	
480 V (+6% -10%) 60 Hz	23 → 17 kVA	

Erection

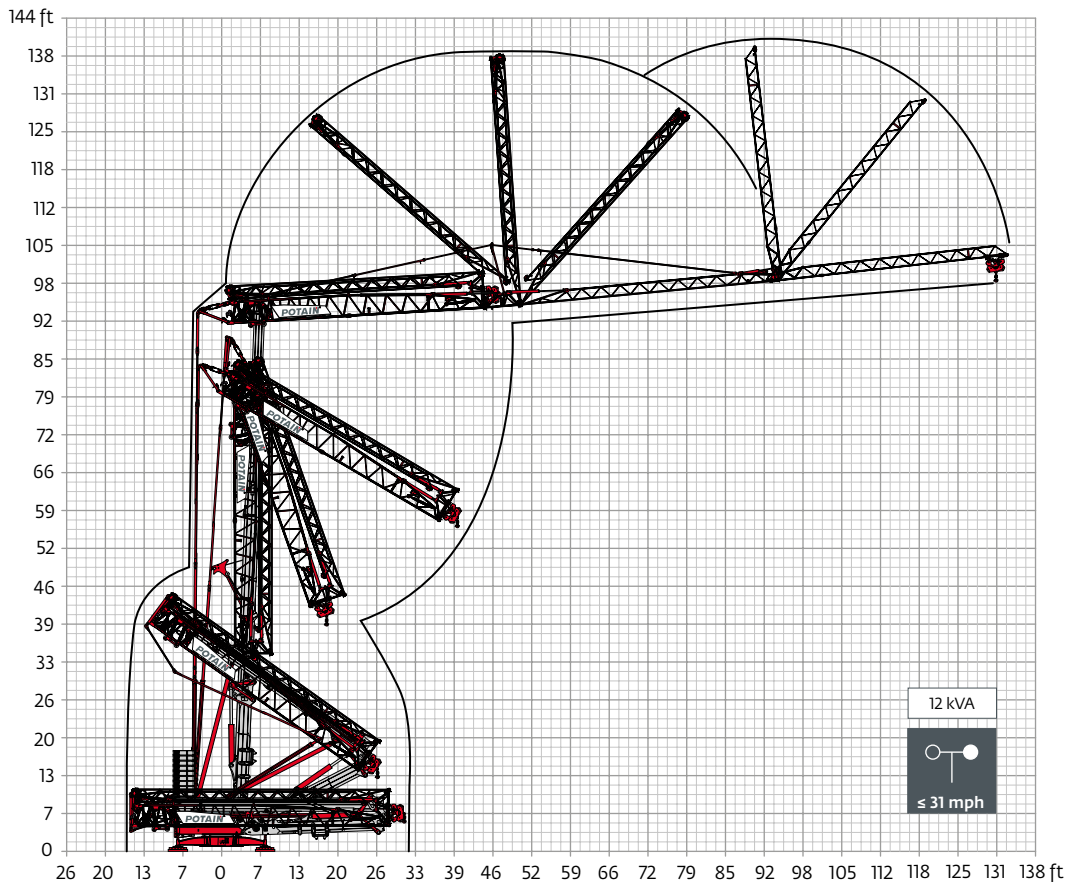

Transport

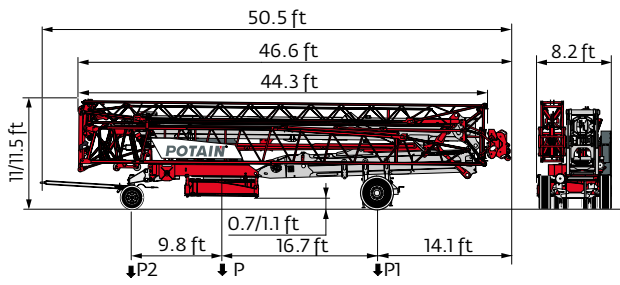

	mph	P (lb)	P1 (lb)	P2 (lb)
DJ100/S120	6	44,798	26,169	18,629
DJ105/S125	15.5	45,371	26,411	18,960

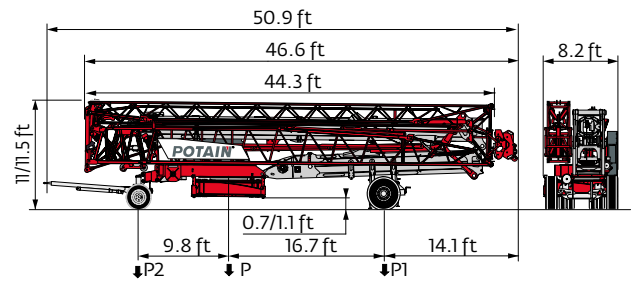

	mph	P (lb)	P1 (lb)	P2 (lb)
DJ126M/S125	15.5	45,812	26,455	19,357
..... /.....				

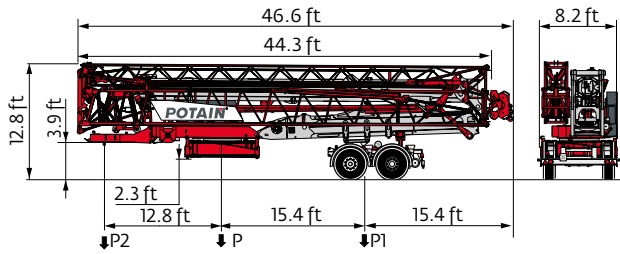

	mph	P (lb)	P1 (lb)	P2 (lb)
SL121/S215M	15.5	48,237	32,430	15,807

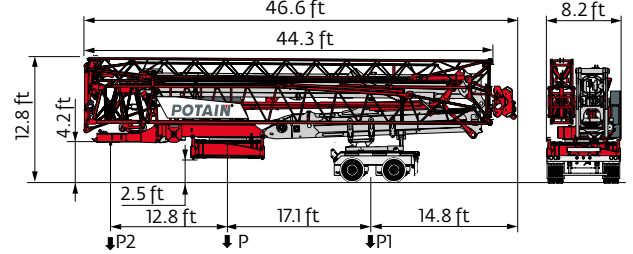

	P (lb)	P1 (lb)	P2 (lb)
North America Highway Axle	47,961	32,132	15,829

- R Rear slewing radius
- i Consult us
- Reactions in service
- Reactions out of service
- ⚖ Weight without load, without ballast, without transport axles, with max. jib and standard height
- ⚖ Total ballast weight
- Standard equipment
- Options
- Hoisting
- Trolleying
- Slewing
- kVA Required power

Power Control Function: which speeds adapted to the available power

This commercial document is not legally binding. For any technical information, please refer to the corresponding instructions.

