

Spindle Roughing Gouge

The name of this tool is blatantly descriptive. It is to be used only for spindle work and for roughing a spindle. It can do smooth cuts if used for thin cuts and slightly skewed/angled. It is for straight cuts only! It does not want to go around corners and the chances of a catch is great increased by doing so.

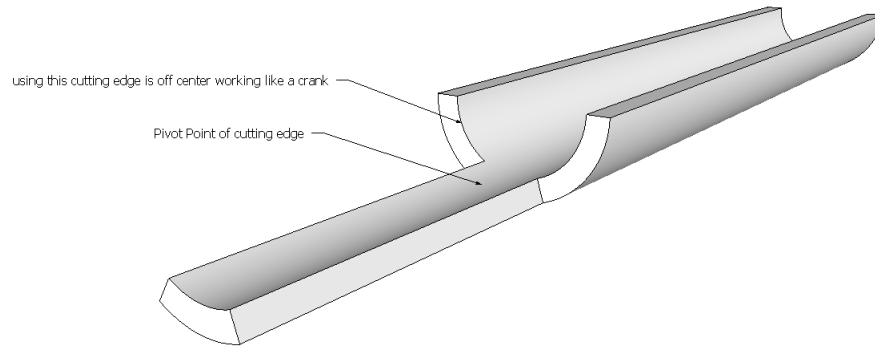

Experts caution that you should never use this tool to rough turn the outside of a bowl. It is thought that the thinness of the tang that goes into the handle makes it too weak to do that. **The truth is:** the grain direction of a typical bowl is perpendicular to a spindle. A spindle is when the grain is parallel to the bed of the lathe. When using the spindle gouge, you are cutting against the side grain whereas when you are turning a bowl, you are alternately cutting side grain and end grain twice for every revolution of the work piece. This means that you are cutting against end grain twice every revolution, causing nasty tear out and the spindle roughing gouge is taking a wide cut so you are developing some horrible tear out and putting more strain on the tool than it is designed to take.

Cutting side/face grain is easy, but end grain is ten times as hard to cut.

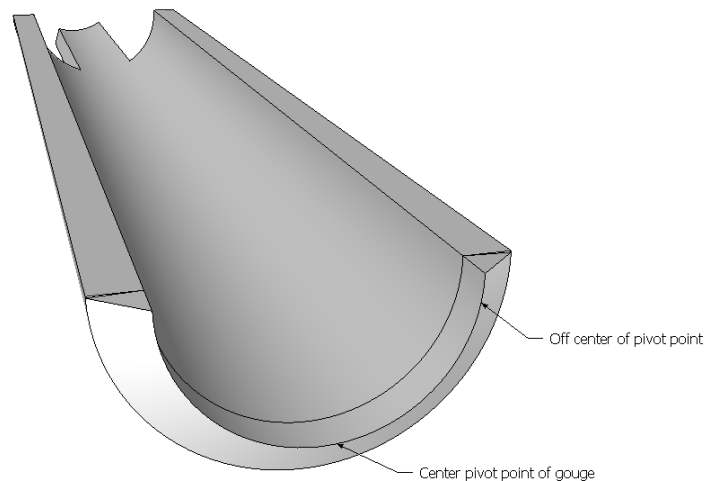





Notice that on this side of the grain, the tool is cutting with the grain



On the opposite side with the tool cutting against the grain, the wood is chipped and tore up



Another thing to think about is that even though the end of the roughing gouge has a lot of cutting edge, it only likes to cut on the middle of the tool. This is due to the fact that the tang is the pivot point of the tool. If you use the cutting edge higher up on the tool, that cutting edge is off the pivot point and forces the tool into a lever requiring a lot of muscle force to keep the tool from returning to its neutral pivot point.

Also due to the fact that the cutting edge is so wide and off center, this tool does NOT like to go around corners, so it should only be used for straight cuts.



Spindle orientation



Cutting from the side with a bowl gouge makes a huge difference

A graphic video on why you don't use a spindle roughing gouge on a bowl: <https://www.youtube.com/watch?v=IOhHeyoZLaY>