



REX Technologie GmbH & Co. KG
Irlachstrasse 31 • A-5303 Thalgau
Telefon +43(0)6235-6116-0 • Fax +43(0)6235-6529
E-Mail: sales@rex-technologie.com
www.rex-technologie.com



INNOVATION & PERFECTION

For Sales And Service Contact



Delivering quality at the right price

Dussen Pty Ltd
Unit 3/70 Andrew Street Wynnum, Qld Australia 4178

Phone: (+61) 7 3393 6552 Fax: (+61) 7 3393 6352
Email: sales@dussen.com.au Website: www.dussen.com.au



The illustrations in this brochure are only a guide, as printed colours and varnishes cannot be displayed in their original brilliance.
Notwithstanding alterations to technical data as well as printing errors.

THE LATEST GENERATION OF VACUUM FILLERS

NEW DIMENSIONS OF THE HIGHEST STANDARD



REX presents new dimensions - vacuum filling machines of the highest standard

The latest REX vacuum filling machines, series 300, 500 and 700 are the result of experience gained over more than 30 years in development and production, making it possible to satisfy a wide range of individual requirements. The use of virtually standardised REX components, with their respective performance capabilities, offers the best technical and economic solution. The new series replaces the well proved and tested REX vacuum filling programme and is the innovative pathfinder for machine processing of various types of liquid or viscous substances.



Services rendered on a permanent basis

Qualified assistance in the choice of the right machine to suit individual requirements, setting up operation and presentation in the works, regular maintenance and prompt customer service are all part of successful and continuing cooperation.



RVF 500



REX Perfection in Development and Technology

The RVF 500 line is designed for the requirements of meat processing industries, as well as middle-sized and larger often highly specialised enterprises. Generally speaking the line stands for:

- high performance density
- exact portioning
- easy change of variety
- multifunctional supplementary possibilities in combination with various clipper appliances and upstream attachments.
- high standard of hygiene and easy cleaning.

Machine casing is self-supporting and made entirely of stainless steel, thus the entire construction surface is smooth and manufacture complies with the highest technical standards. The vane cell feed system is the same size and has the same characteristics as the RVF 700. The smaller model of the RVF 500 can also be delivered in combination with conventional forcemeat in-feed.

There is a wide choice of hoppers in various sizes to suit each enterprise. The following hoppers for the RVF 500 are available:

- 150 litre hopper
- 250 litre hopper fold-away
- 350 litre hopper fold-away

Vane cell feed system



Hopper 150 litre



Fold-away hopper: 250 resp. 350 litre



Scale drawings of RVF 500 with 150, 250 i.e. 350 litre hopper

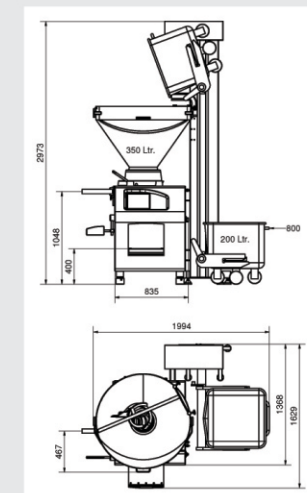
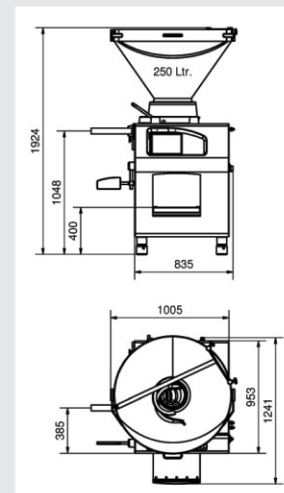
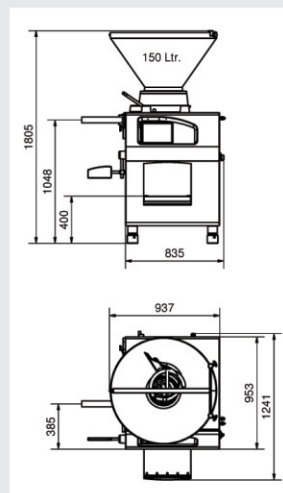

DETAILS - THE FUNDAMENTAL BACKGROUND

The REX-servo-drive, used effectively in all Rex-machines for the last 15 years, has been improved in performance by the latest drive concept, standing for:

- practically maintenance free for many years
- exact portioning
- low energy consumption
- smooth and quiet operation



Advanced control technology - simple operation for economic production

The fully integrated REX touch-screen is installed in all series and offers the user the easiest operating and adjustment possibilities. All set values such as weight, speed etc. are permanently screened and can be adjusted by the

operator at any time. This ensures optimal efficiency. The operator is kept up to date on routine maintenance by integrated maintenance interval indicators. The built-in modem i.e. Ethernet interfaces permit direct communication between machine, internal plant facilities and external service. Thus service and program data can be exported or imported. The controls allow activation of metal detectors for metal screening at any time. Moreover the controls support all common European languages as also far-eastern typesets.



The additional protection covering

The touch panel guard, which can be attached to the filling machine on request, offers optimum protection for the controls.



Holding devices 320 and 400

The holding devices can be simply inserted in the connector of the linking transmission on the filling device and removed or swung sideways for cleaning after production. They ensure excellent performance for linking of all artificial and collagen casings as well as all sorts of natural casings. The correct type of device is chosen prior to purchase according to individual requirements for the existing casing feeders.



Fixed holding device

This holding device can be simply attached to the filling device in combination with the linking transmission and offers excellent results for linking all sorts of natural casings.



Forcemeat cutter

The pneumatic forcemeat cutter can be easily attached to the evacuation of the filling device. It is ideally suited to cutting filling substances (Çevapcici...). The exact size of each portion is specified by the filling device. Various sized filling tubes can be attached if required.

FILLING-SHREDDER TECHNOLOGY OFFERS A WIDE RANGE OF APPLICATIONS

The series RVF 700 and 900 allow attachment of a Filling-Shredder whenever re-quired. The independent servo-drive of the Filling-Shredder, operated by the touch screen controls, makes it possible to adapt the cutting speed to individual require-ments.

The Filling-Shredder can be used either with the straight filling tube, a sausage casing holder or together with all current clipper appliances. Furthermore there is the possibility for portioning minced meat. Models are available with a 3 part or 5 part cutter unit.

Filling-Shredder technology



Downstream breaker plate from 1.5 - 8 mm



5 part cutter unit



THE REX ATTACHMENT TROLLEY

The attachment trolley provides practical storage for all machine parts and attachments after manufacture. It also facilitates cleaning of all parts after use.





TECHNISCHE DATEN

AUF EINEN BLICK

TYPE	Filling capacity	Hopper size	Filling pressure (nominal pressure)
RVF 327 	2700 kg/h	90/150 l	40 bar
RVF 540 	4000 kg/h	150/250/350 l	35 bar
RVF 736 	3600 kg/h	250/350 l	70 bar
RVF 740 	4000 kg/h	250/350 l	35 bar
RVF 760 	6000 kg/h	250/350 l	45 bar
RVF 761 	6100 kg/h	250/350 l	70 bar
RVF 911 	11.000 kg/h	350 l	40 bar
RVF 913 	13.000 kg/h	350 l	35 bar

Portioning and linking speed <small>(1 no. of portions depends on linking time and filling intervals)</small>	Power rating <small>*with shredding drive</small>	Shredding system <small>(optional)</small>	Elevator <small>(for standard lifting carts)</small>	Weight <small>(entire equipment)</small>
10 g ca. 700 port./min. 40 g ca. 350 port./min. 100 g ca. 300 port./min. 200 g ca. 200 port./min.	5 kw	no	on request	450 kg
10 g ca. 1000 port./min. 40 g ca. 400 port./min. 100 g ca. 300 port./min. 200 g ca. 250 port./min.	8 kw	no	forcement elevator 120 + 200 litres	700 kg
10 g ca. 1000 port./min. 40 g ca. 450 port./min. 100 g ca. 300 port./min. 200 g ca. 250 port./min.	11 kw *15 kw	yes	swing arm infeed 200 litres	900 kg
10 g ca. 1000 port./min. 40 g ca. 450 port./min. 100 g ca. 300 port./min. 200 g ca. 250 Port./min.	8kw *15 kw	yes	swing arm infeed 200 litres	1000 kg
10 g ca. 1200 port./min. 40 g ca. 650 port./min. 100 g ca. 500 port./min. 200 g ca. 350 port./min.	11 kw *15 kw	yes	swing arm infeed 200 litres	1100 kg
10 g ca. 1200 port./min. 40 g ca. 650 port./min. 100 g ca. 500 port./min. 200 g ca. 350 port./min.	15 kw *18 kw	yes	swing arm infeed 200 litres	1100 kg
10 g ca. 1200 port./min. 40 g ca. 700 port./min. 100 g ca. 550 port./min. 200 g ca. 380 port./min.	22 kw *25 kw	yes	swing arm infeed 200 litres	1300 kg
10 g ca. 1200 port./min. 40 g ca. 700 port./min. 100 g ca. 550 port./min. 200 g ca. 380 port./min.	22 kw	no	swing arm infeed 200 litres	1300 kg

Optional equipment:

-  Metal detector connector
-  Closed heat able twin hull hopper
-  Special model capable of filling hot forcemeat
-  Touch panel guard
-  Further special designs on request