

## GibbsCAM Production Systems: Milling, Turning, and Mill-Turn

GibbsCAM simplifies the complex, with the power to meet the challenges of the most demanding shop. GibbsCAM Production Milling and Production Turning provide a reliable foundation for general machining and a solid platform for growth.

Production Milling supports 2-axis, 2.5-axis, and 3-axis wireframe machining, with 4th axis positioning. Production Turning supports full 2-axis wireframe machining. By combining them, you gain mill-turn function with live tooling.

### System-Wide Capabilities

A friendly user interface with intuitive icons makes navigation fast and programming easy. Users get up to speed quickly, making CNC programming and machining efficient and productive. You will achieve faster programming, faster machining, and more parts out the door, all while increasing capability and reducing programming costs.

#### **Unique Graphical Interface:**

- Designed for machinists, with shop-familiar terminology
- Graphic icons that make sense to machinists
- Mode-less access to allow moving between functions without stepping through multiple menus. Jump from toolpath verification to part design to tool definition and back any time
- Consistent across the product line, so all modules look and feel the same

# Production Turning

Production Turning supports full 2-axis wireframe machining, with graphic tool definition and tools that simplify and automate lathe programming, all to make your lathes and turning centers as efficient as possible.

- Advanced roughing routines
  - Roughing cycles for plunge roughing
  - Automatic shoulder stroking
  - Pattern shift roughing with constant path and constant step-over options

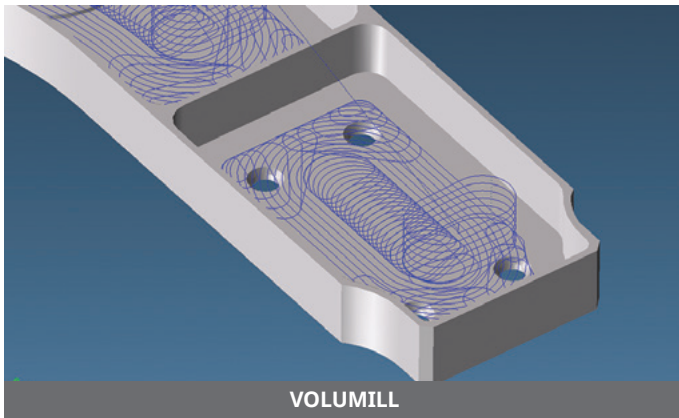

- Automatic calculations to optimize tool entries, exits and other motion
  - Stock remaining to avoid “cutting air” and avoid material during rapid moves
  - Material-only roughing and contouring
  - Automatic clearance to keep tool optimally positioned
- Threading and thread whirling follow all shapes, including arcs and splines
- Threading data library:
  - Threading data for over a dozen standards
  - Supports top-notch, LT, cresting, and multiform inserts
  - Includes multiple in-feed options
  - Supports multi-start threads and auto spring passes
- Grooving support for Fanuc-style G74 and G75 cycles

# Mill-Turn Machining

By combining Production Milling and Production Turning, you gain mill-turn capability, with support for X, Y, Z linear axes plus a C or B rotary axis. Fast parametric radial duplication of repetitive operations and of features such as holes, slots, pockets and flats makes quick work of complex mill-turn parts.

- C-Axis programming
- Live tooling for any number of tools
- Face and diameter milling
- Y- and B-axis support for milling
- B-axis angular orientation for turning
- B-axis simultaneous turning

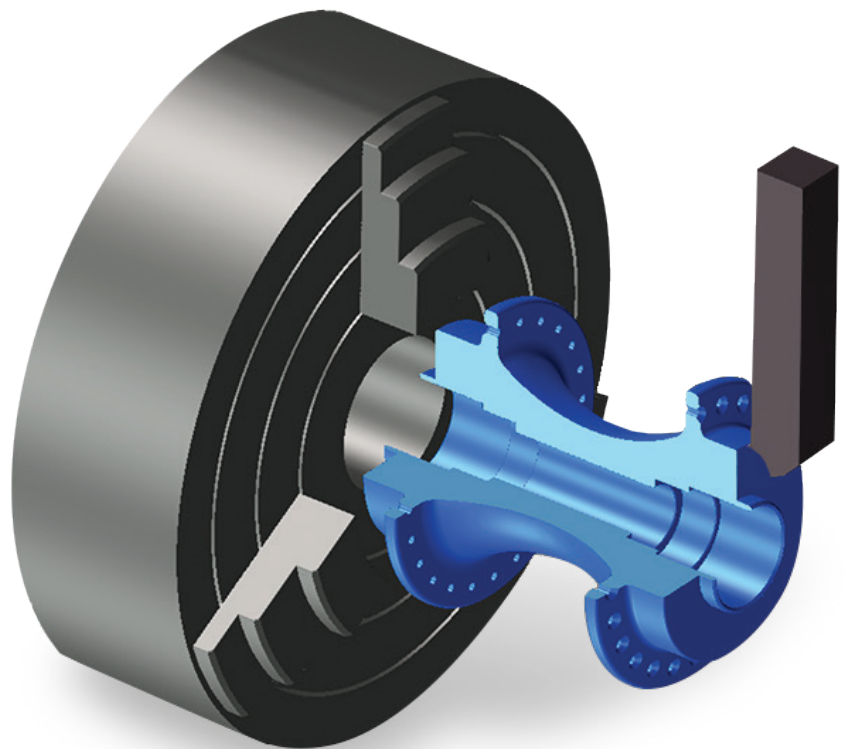

# System-Wide Capabilities

**Tool Visualization:** Visualize tools, tool holders, and tool blocks as they are actually situated and oriented in tool groups such as turrets and gangs, all with full pan, rotate and zoom

**Flexibility:** Choose from multiple machining styles best suited to your machining requirements

**Associativity:** GibbsCAM creates and maintains relationships between geometry, cutting tools, machining process and toolpath, to automatically update related components when a change is made.

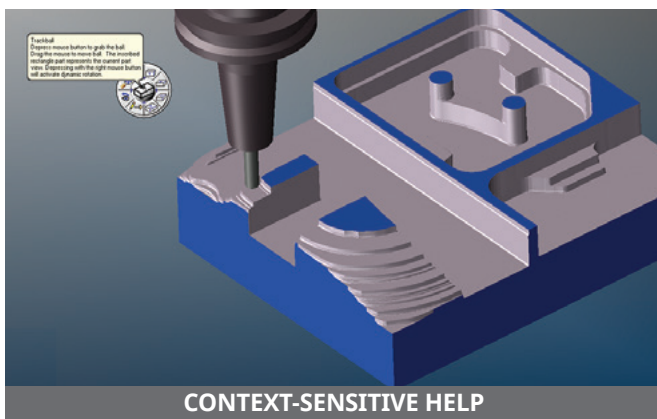

**Multiple Interface Levels Available:** Display only the elements you need, simplifying the interface for even faster navigation and higher programming efficiencies

**Online Help**, available at any time, is context-sensitive. Learning is assisted with on-screen reference balloons and action-specific prompting

**Toolpath Verification and Visualization**, with 3D rendering of the toolpath, showing cutting action and an accurate preview of machining and surface finish.

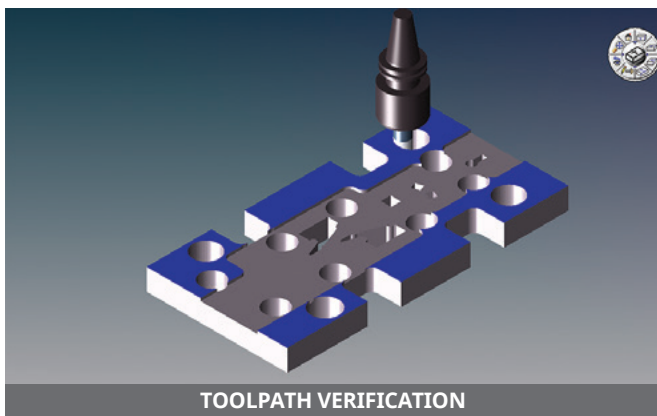

**Post Processors** for your machines are available from the huge factory-maintained library of thousands of post processors, or have us build custom posts for you

**Network License Option\*** allows you to take advantage of a shop or company network, maximizing the use and benefits of your investment

## CAD and Geometry

Whether you start with imported geometry or create your own, GibbsCAM's free-form tools provide quick and easy methods for creating, manipulating and editing machinable geometry, all assisted by automation tools and modeling techniques.

- Create free-form machinable geometry – points, lines, circles, splines and offsets – in any order
- Create machinable contours from a chain of intersecting lines and circles
- Automatically create fillets, chamfers, ellipses, rectangles, polygons, holes, cams and gears, including spline and involute
- Automatically create D-holes, double D-holes, 2D



- spirals, 3D spirals, and tapered threads
- Manipulate shapes as regions that can be combined (through union, subtraction or intersection), broken into segments, sliced, or trimmed inside or outside
- Query models with the Profiler tool, and lift cross-sectional geometry in any orientation, including silhouettes, spun outlines and cylindrical slices
- Gain 4th and 5th axis positioning with the Advanced Coordinate System option\*

- Multiple CAD interoperability options allow GibbsCAM to operate with all popular CAD systems
  - DXF, DWG and IGES import formats are standard
  - Additional industry standard and proprietary formats supported through other machining or data exchange options, from data import, to data exchange, to direct model transfer\*
- Gain 4th and 5th axis positioning with the Advanced Coordinate System option\*
- Import solid models and machine in wireframe from extracted edges\*

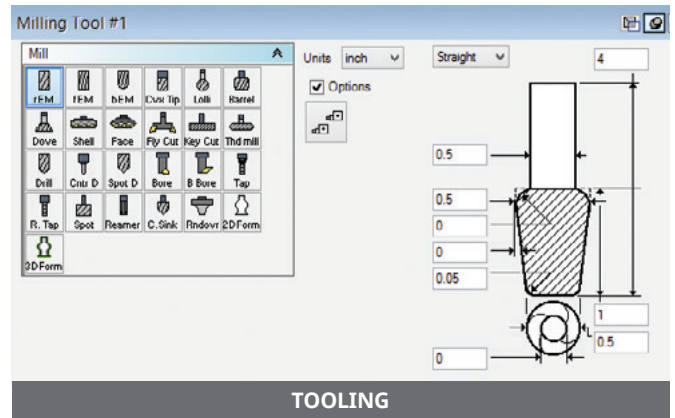

## Tooling

GibbsCAM enables creating, displaying and managing all tool types for use in programming and verifying toolpath. A graphic display, with dimensional dialog, simplifies error-free tool definition, with support for predefined tools, tool inserts, and user-defined form tools.

- Create and store custom form tools for lathes and mills, with draft angles and corner radii
- Create and store custom tool holders
- Maintain the tool library for all types of tools
- Easily arrange tool order for each job
- Directly access on-line Iscar Tool Advisor to load tool definitions from Iscar catalog

- Integration with Adveon Tool Library lets you:
  - Import tools from Sandvik Coromant and ISO-13399-compliant systems
  - Maintain latest tool data
  - Build, save and reuse tools
  - Link tools and tool assemblies to parts, for reuse any time



# CNC Programming and Machining

GibbsCAM provides many options for generating toolpath. To maximize programming and machining efficiency, it maintains relationships between tools, parts, features and toolpath strategies. Even so, its many automation tools never force the user into default processes. You can realize all the productivity your machines can deliver, because GibbsCAM provides the flexibility to let you program in styles best suited for the part, designated machine, or shop practices.

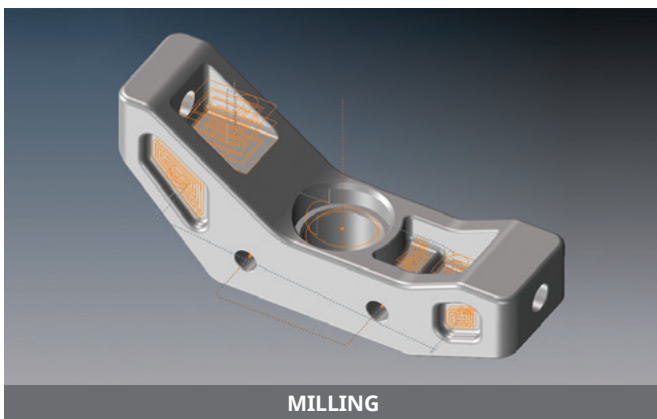

- Quickly machine a part with Multiple Process Programming
  - Select geometry once, and apply multiple roughing, semi-roughing, finishing or multi-tool hole operations
- Quickly make a change in geometry or tools and let the system's full associativity automatically reprogram operations
- With knowledge-based machining, save and reuse processes(multi-operation processes) with associated tooling for new or modified parts or CNC programs
- Dynamically adjust start and end points of toolpath without editing or chaining geometry
- Adjust feed rate easily, anywhere on the toolpath
- Maintain the materials library, with feeds and speeds, for different materials and conditions
- Use material-only rest machining to avoid "cutting air"
- Sort all operations to minimize tool changes and optimize machining
- Use system-estimated run times for planning or optimization
- Output process summary directly to Microsoft Excel file to generate shop routers and tool lists

# Production Milling

Production Milling gives you 2-axis, 2.5-axis and 3-axis machining with simple 4th axis positioning, with full functionality for all types of machining, which include the following:

- 2- through 3-axis milling (extendable to 4- & 5-axis simultaneous)\*
- Multiple toolpath strategies for contouring, pocketing, drilling, boring and face milling
- Advanced pocketing routines to:
  - Pocket any number of shapes simultaneously
  - Machine pockets with any number of bosses or islands
  - Define and recognize open wall pockets with versatile extension options
- Automatic face milling cycles, such as spiral, zig-zag, back-and-forth, and unidirectional
- Hole Wizard to guide definition of tools and processes for 8 different hole types

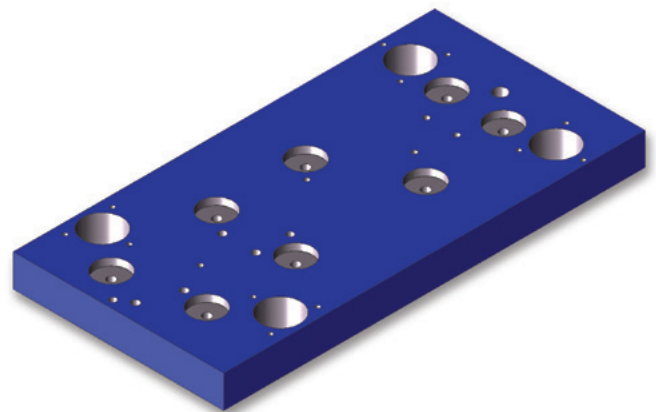

- All drill, peck, tap and bore cycles are supported:
  - User-definable settings
  - User-defined toolpath using macros for custom cycles
  - Drilling and thread milling patterns
- Boring and drilling subroutines, such as bore, fine bore, and back bore
- Create and mill ID and OD threads, with support for tapered thread milling
- Engraving, to machine both artwork and True-Type fonts
- Cutter radius compensation techniques for tool edge and tool center compensation
- VoluMill™ Wireframe for GibbsCAM, to add powerful high-speed roughing

# Extend your Capabilities

As your shop grows, or replaces machinery, GibbsCAM helps you grow. Multiple options integrate with the same familiar, intuitive interface allowing you to continue to program any part for efficient machining on any machine.



- 2.5D Solids: Simple solid modeling and solids-based machining of 2-, 2.5- and simple 3-axis parts
- SolidSurfacer (3D Milling): Advanced surface and solid modeling plus 3-axis surface machining
- Polar & Cylindrical Milling: Drive one rotary and two linear axes on machines with a rotary axis
- Radial Milling: Drive one rotary and three linear axes with off-centerline "Y-axis" milling and wall angle control
- 5-Axis: 5-axis simultaneous milling of surfaces and solids
- 5-Axis MultiBlade: Specialized interface for machining bladed turbo-machinery parts (impellers, rotors, blisks and blings)
- 5-Axis Porting: Specialized interface for machining engine ports and similar through-part openings
- Multi-Task Machining (MTM): Turning and milling with multiple spindles and tool-groups
- VoluMill™ for GibbsCAM: Adds powerful high speed roughing with volumetric material removal to GibbsCAM milling
- Tombstone Management System (TMS): Multi-part layout and programming for tombstone fixtures
- Machine Simulation: Build machine models and simulate machine tool motion
- Wire-EDM: 2- through 4-axis Wire-EDM

*\*Items marked with an asterisk (\*) are optional functions, which are licensed separately.*