

BEST CONTACTS FOR YOUR SUCCESS



Telegärtner

KARL GÄRTNER GMBH

NETWORKING COMPONENTS

COAXIAL CONNECTORS

CABLE ASSEMBLIES

PRECISION TURNED PARTS

PLASTIC INJECTION MOULD PARTS

INDUSTRIAL ELECTRONICS

**Simpler all over.
Simpler all round.**

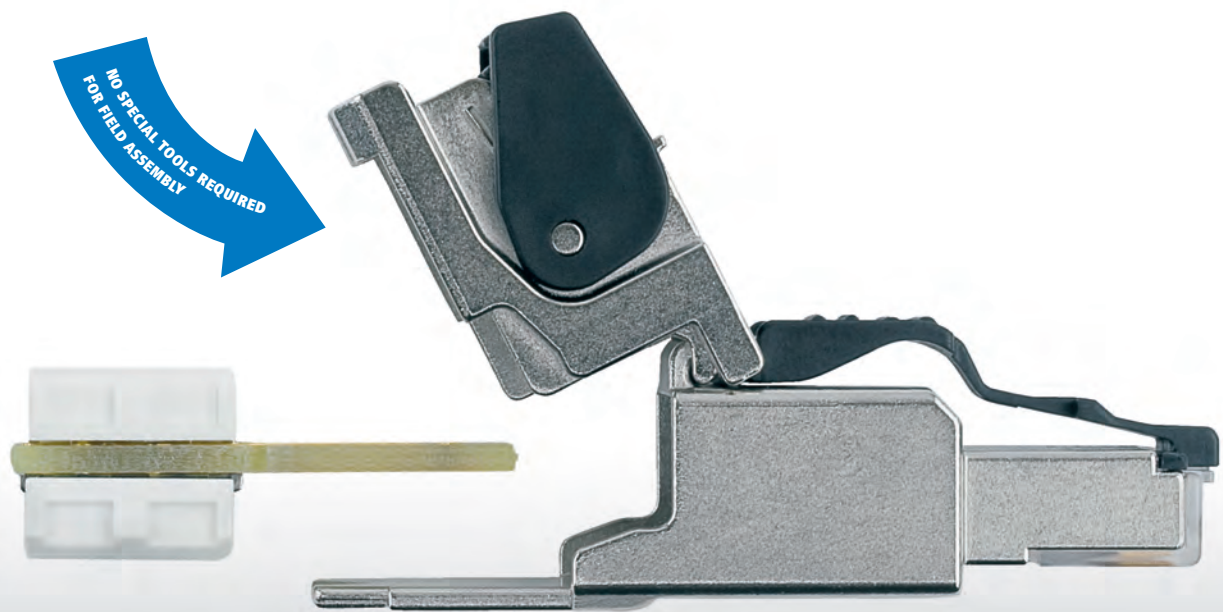

Cat.6A 10 GB Ether. 500 MHz fully shielded PoE+

Data Voice

MFP8 Cat.6A

Field assembly RJ45 plug

Less fuss. More flexibility.

Here's the situation: An existing network needs extending. A cable link needs to be repaired or replaced. A peripheral device needs to be connected quickly. Your customer expects a fast and reliable solution but you don't have a cable assembly ready at hand. Sound familiar?

Now you can keep your cool when faced with such demands – with the new, field assembly MFP8 Cat.6_A plug developed by Telegärtner.

The MFP8 Cat.6_A is the RJ45 plug for time-saving and efficient on-site assembly for all networks, from Voice right through to 10 Gigabit Ethernet. It can be assembled on all standard types of cable in just 60 seconds – and no special tools are required.

Whether in the office, data centers, in industry or in home networks – the MFP8 Cat.6_A offers unprecedented flexibility and saves time and money on installation, repairs and maintenance.



Simpler all over: MFP8 Cat.6_A applications

The new field assembly MFP8 Cat.6_A is the number one choice whenever efficient and reliable connections are needed without major expense or effort, whether for classic cabling systems in office buildings, data centers, in industry or for home cabling systems. Needless to say, it also supports High Power over Ethernet plus (PoE+).



Office/premise cabling and data centers

With the MFP8 Cat.6_A, installers and network professionals now have access to an RJ45 plug which will enable them to respond with speed and flexibility, even at short notice, to any requirement, be it cabling for workstations, connections for equipment or backbone extensions.

Connections can be made with all standard cable types, even with transfer rates of 10 Gigabit Ethernet (10GBase-T), without requiring hours of preparation and without the need for special tools. It is particularly cost-effective for connections in data centers where every centimeter counts. Space problems due to surplus cable are consigned to the history books. Thanks to its compact design and suitability for multiport applications, the MFP8 Cat.6_A can also be used where space is at an absolute premium.

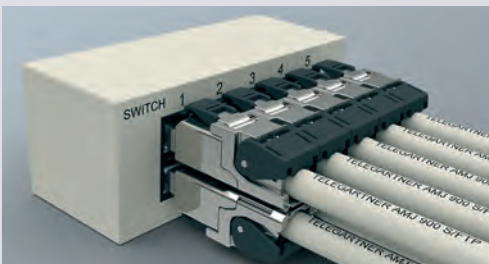

Industrial cabling (IP20)

Whether used in industrial control cabinets or in distribution boxes in production, the MFP8 Cat.6_A can also be relied upon in industry. The 360° shielding and full metal housing guarantee secure and reliable data transmission, including with 10 Gigabit Ethernet and even with outside electric interference. And the use of the full range of cable types with solid or stranded conductors from AWG24/1 to 22/1 and AWG27/7 to 22/7 make it a universal product fit for all purposes.



Cabling in the home

When it comes to home networks or cabling for the home-based office, adhering to a minimum footprint is normally a major requirement, and only very rarely is there an outlet just where one is needed. In order to be able to connect the PC, router or printer quickly, easily and cheaply, a plug is needed which can be fitted without special tools to the full range of cable types with solid or stranded wires. The MFP8 Cat.6_A enables to assemble and customise cables – as and where they are needed – and to establish efficient and reliable connections without spending a great deal of time and money.

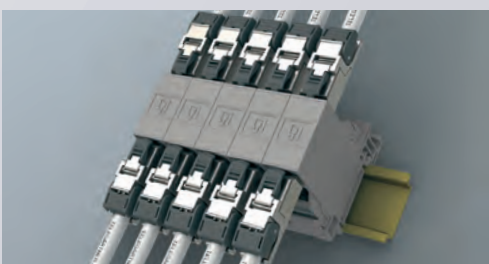

The best bits of 60 years of experience all rolled into one plug

For over 60 years Telegärtner has had a determining influence on the direction taken by connector technology in terms of convenience, reliability and performance. "Made in Germany" development, design and state-of-the-art production – the sum total of decades of experience can be found invested in the new MFP8 Cat.6A.

Long release latch

Insertion and withdrawal made easy in confined spaces

Preassembled protection cap

Effective protection of contacts from dirt and damage in transit

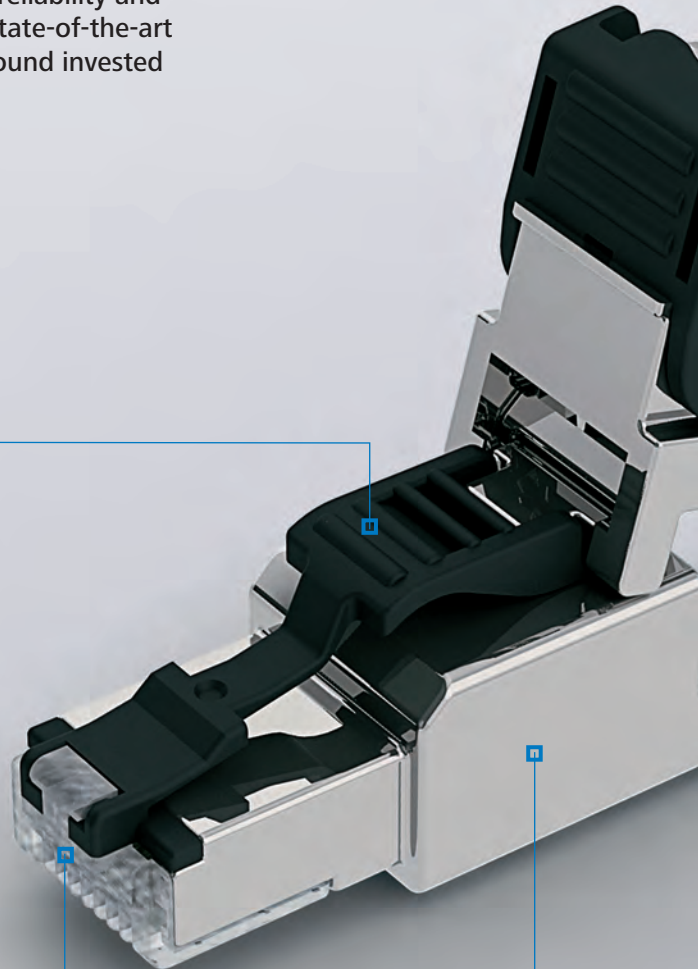
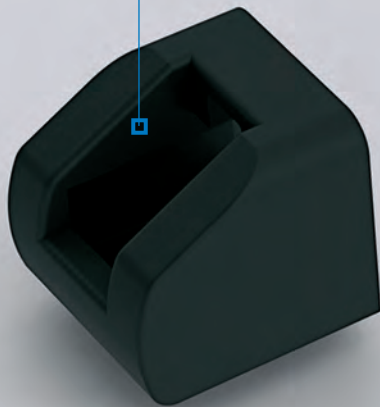

Standardised plug interface

Conforming to EN 60603-7-51

Robust zinc die-cast housing

Hardened and tempered finish to prevent electrical interference

Specifications:

- Categorie 6A: ISO/IEC 11801:2010 compliant
- Plug: IEC 60603-7-51 compliant
- Life: ≥ 750 mating cycles
- contact finish material: Ni1.2Au0.8
- Shielding housing material: Die-cast nickel-plated zinc
- Cu conductor diameter:
(J00026A2000, -1, -2, -2110, -2111, -2112)
solid 0.51 – 0.64 mm (AWG 24/1 – 22/1)
stranded 0.46 – 0.76 mm (AWG 27/7 – 22/7)
stranded 0.61 – 0.78 mm (AWG 24/19 – 22/19)*
Core diameter: 1.0 – 1.6 mm
- Cu conductor diameter:
(J00026A2003, -4, -2113, -2114)
solid 0.41 – 0.51 mm (AWG 26/1 – 24/1)
stranded 0.46 – 0.61 mm (AWG 27/7 – 24/7)
stranded 0.51 (AWG 26/19)*
- Core diameter: 0.85 – 1.1 mm
- Outer diameter of cable: 5.0 – 9.0 mm
- Reusable IDC: ≤ 4 cycles
- Temperature range: -40°C to 85°C
- High Power over Ethernet plus (PoE+) in accordance with IEEE 802.3at

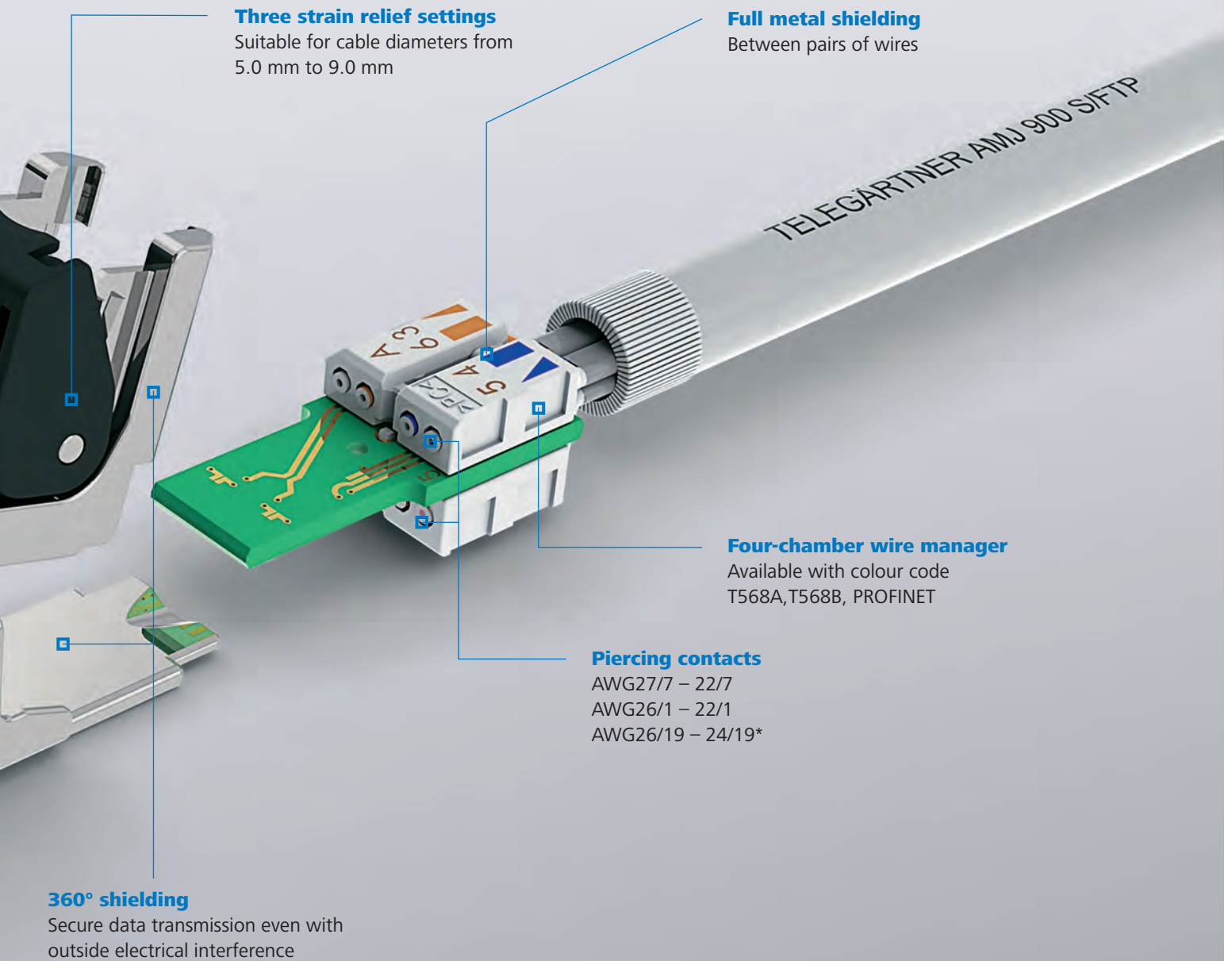

Three strain relief settings
Suitable for cable diameters from
5.0 mm to 9.0 mm

Full metal shielding
Between pairs of wires

Four-chamber wire manager
Available with colour code
T568A, T568B, PROFINET

Piercing contacts
AWG27/7 – 22/7
AWG26/1 – 22/1
AWG26/19 – 24/19*

360° shielding
Secure data transmission even with
outside electrical interference

Field assembly plug MFP8:



MFP8 T568A Cat.6_A
AWG24-22/1, AWG27-22/7, AWG24-22/19*
Order no.: J00026A2000 (1 pcs. in bag/10 pcs. in carton)
Order no.: J00026A2110 blister package (10 pcs.)



MFP8 T568B Cat.6_A
AWG24-22/1, AWG27-22/7, AWG24-22/19*
Order no.: J00026A2001 (1 pcs. in bag/10 pcs. in carton)
Order no.: J00026A2111 blister package (10 pcs.)

MFP8 T568A Cat.6_A
AWG26-24/1, AWG27-24/7, AWG26/19*
Order no.: J00026A2004 (1 pcs. in bag/10 pcs. in carton)
Order no.: J00026A2114 blister package (10 pcs.)

MFP8 T568B Cat.6_A
AWG26-24/1, AWG27-24/7, AWG26/19*
Order no.: J00026A2003 (1 pcs. in bag/10 pcs. in carton)
Order no.: J00026A2113 blister package (10 pcs.)

MFP8 PROFINET
AWG24-22/1, AWG27-22/7, AWG24-22/19*
Order no.: J00026A2002 (1 pcs. in bag/10 pcs. in carton)
Order no.: J00026A2112 blister package (10 pcs.)



Wire Manager
AWG24-22/1, AWG27-22/7, AWG24-22/19*
Order no.: **T568A:** F00020A2130 (30 pcs. in blister)
Order no.: **T568B:** F00020A2131 (30 pcs. in blister)

Wire Manager
AWG26-24/1, AWG27-24/7, AWG26/19*
Order no.: **T568A:** F00020A2134 (30 pcs. in blister)
Order no.: **T568B:** F00020A2133 (30 pcs. in blister)

Wire Manager PROFINET
AWG24-22/1, AWG27-22/7, AWG24-22/19*
Order no.: F00020A2132 (30 pcs. in blister)

Simpler all round: Fitting the MFP8 Cat.6_A

The MFP8 Cat.6_A consists of just two parts which can be assembled quickly and securely in three simple steps.

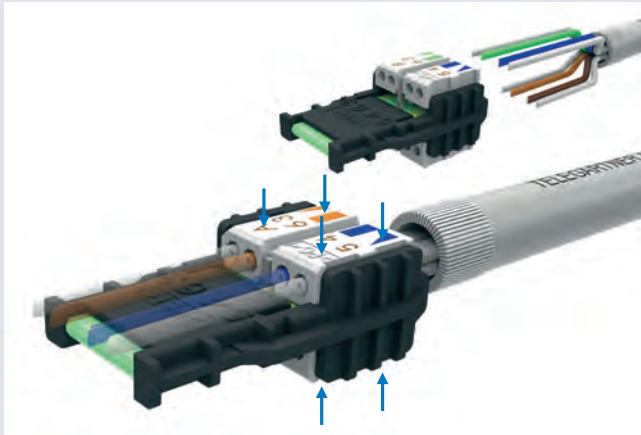

Step 1: Connect cable

Remove cable jacket, move cable shielding backwards and prepare wires by untwisting pairs and inserting them in the wire manager. The integrated assembling aid protects the board and facilitates this process. The print is highly visible and is available in colour code T568A, T568B or PROFINET. Press wire manager together with a plier and cut off excess wires.

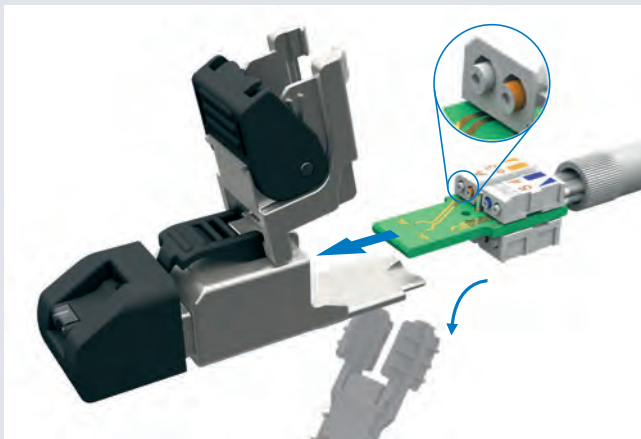

Step 2: Insert in plug housing

Remove assembling aid and insert board with wires connected in plug housing. The wire manager is designed so that it can only be inserted in the housing the right way up.

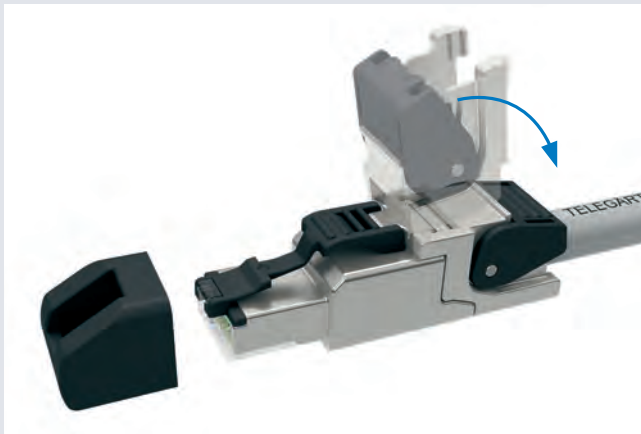

Step 3: Close plug

The cable relief is hinged to ensure 360° shielding and effective strain relief on the cable. The snap-in mechanism can be adjusted to tailor the amount of grip to the cable diameter in any given case. And the cap protects the plug contacts from dust and dirt.

MFP8 Cat.6_A: For new freedom in structured cabling

- ✓ Can be assembled in 60 seconds without any special tools
- ✓ Optimised for the field, including demanding applications
- ✓ Suitable for cabling in office buildings, data centers, industrial facilities and home networks
- ✓ Supreme reliability
- ✓ Secure transmission even with outside interference
- ✓ Ideal for network repairs, special length and extensions

Designed to make things simpler for pre-assembled solutions: the TICNET configurator

The TICNET configurator is a convenient and quick way of ordering preassembled cabling components from the factory. Just follow six simple steps to order the product you need:

- 1 Select type of product
- 2 Define product
- 3 Check final product
- 4 Add product to shopping basket
- 5 Enter address details
- 6 Send inquiry

Whether you need copper or optical fiber products, cables or patch panels, solutions for office buildings, data centers, industrial facilities or home networks: the TICNET configurator service is available around the clock to inquire customised products. Naturally it is also possible to save your configurations.

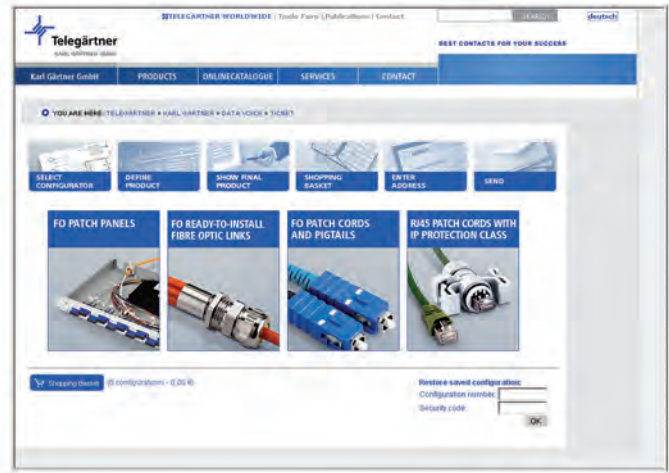

Easy, quick and reliable: that's Telegärtner
www.telegaertner.com/ticnet

Telegärtner
Karl Gärtner GmbH

Lerchenstr. 35
D-71144 Steinenbronn

Tel.: +49 (0) 71 57/1 25-100
Fax: +49 (0) 71 57/1 25-120

Email: info@telegaertner.com
Web: www.telegaertner.com

Your distributor:

Official Canadian Value Added Distributor

Tel: +1-905-237-4732 E-Mail: info@a-n-d.ca
www.a-n-d.ca