

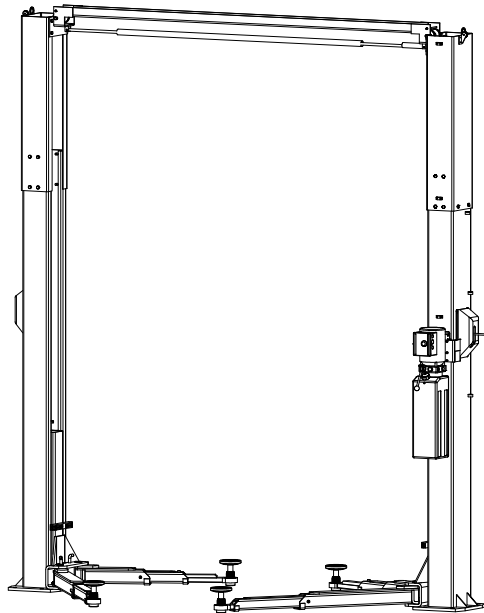

INSTALLATION, OPERATION & MAINTENANCE MANUAL

Two Post Surface Mounted Lift



MODEL Q10

10,000 LBS. CAPACITY
2500 LBS. PER ARM

QUALITY LIFTS, LLC
200 Cabel St., P.O. Box 3972, Louisville, KY 40206
FAX: 502-583-5488
TOLL FREE: 877-771-5438
E-mail: sales@qualitylifts.com
www.qualitylifts.com

**IMPORTANT: READ THIS MANUAL COMPLETELY BEFORE
INSTALLING or OPERATING LIFT**

GENERAL SPECIFICATIONS

| See Figure 1 | Q10 |
|--|---------------------------------------|
| A Rise Height (Screw Pads Highest Position) | 78 3/4" (2000mm) |
| B Overall Height (Adjustable) | 147 1/2" (3748mm) / 137 1/2" (3494mm) |
| C Overall Width | 131 3/4" (3347mm) |
| D Drive-Thru Clearance | 98 3/8" (2499mm) |
| E Floor to Overhead Switch | 140 1/2" (3568mm)/ 130 1/2" (3314mm) |
| F Short Arm Reach | 21 3/4"-39 1/4" (553mm-998mm) |
| G Long Arm Reach | 38 1/4"-55 3/8" (971mm-1407mm) |
| H Screw Pad Height | 4 1/4"-7 3/4" (109mm-199mm) |
| K Inside of Columns | 110 1/4" (2800mm) |
| Lifting Capacity * | 10,000 lbs. (4536 kg) |
| Ceiling Height Required | 149" (3785mm) |
| Motor | 2HP, Single Phase, 60Hz |
| Voltage | 208-230 |
| Speed of Rise ** | 52 seconds |
| Max Load Per Arm | 2500 lbs (1134 kg) |

* Lift capacity ratings are based on loads equally distributed on all four arms.

** Lifting and lowering speeds may vary depending on the weight of the vehicle.

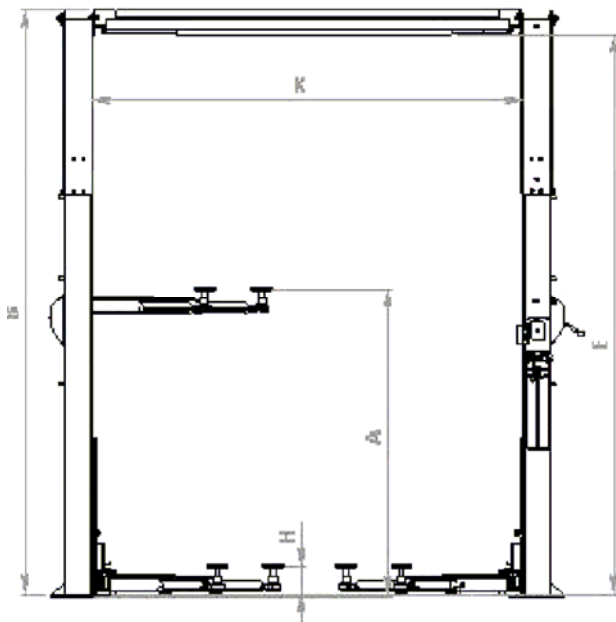

Fig 1a - General Specifications

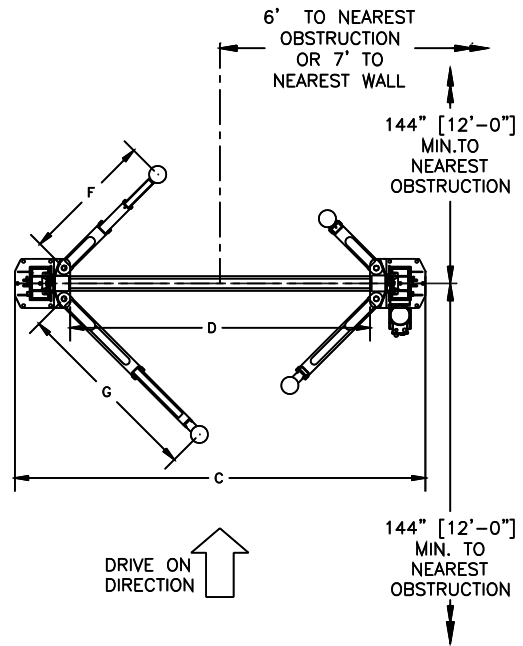

Fig1b - Service Bay Layout

VERTICAL CLEARANCE

Check the height of the area where the lift is to be installed. Clearance should be calculated based on the full raised height of the lift.



WARNING Failure by purchaser to provide adequate clearance could result in unsatisfactory lift performance, property damage, or personal injury.

FLOORING

Be certain you have the proper concrete floor to properly handle the loaded lift. Floor should be in generally good condition with no large cracks, spalling or deterioration.

Minimum requirements for concrete are 4 inches minimum depth, with steel reinforcement, 3500 psi, cured for 28 days per local commercial practice. Floor should be level within 3/8 inch over the installation area. No anchors should be installed within 8 inches of any crack, edge, or expansion joint. If these conditions cannot be met, a pad may be poured to accommodate the lift.

Check with local building inspectors and/or permits office for any special instructions or approvals required for your installation.



WARNING Failure by purchaser to provide the recommended mounting surface could result in unsatisfactory lift performance, property damage, or personal injury.

LOCATION

This lift has been evaluated for indoor use only with an operating ambient temp. range of 5 – 40°C (41– 104°F)

ELECTRICAL REQUIREMENTS

For lift installation and operation for single phase units, it is necessary to have a dedicated circuit with a double pole 25 amp circuit breaker or time delay fuse.

SAFETY NOTICES AND DECALS

For your safety, and the safety of others, read and understand all of the safety notices and decals included here.

READ ENTIRE MANUAL BEFORE ASSEMBLING, INSTALLING, OPERATING, OR SERVICING THIS EQUIPMENT. PROPER MAINTENANCE AND INSPECTION IS NECESSARY FOR SAFE OPERATION. DO NOT OPERATE A DAMAGED LIFT.

Safety decals similar to those shown here are found on a properly installed lift. Be sure that all safety decals have been correctly installed on the Power Unit reservoir. Verify that all authorized operators know the location of these decals and fully understand their meaning. Replace worn, faded, or damaged decals promptly.



WARNING Do not attempt to raise a vehicle on the lift until the lift has been correctly installed and adjusted as described in this manual.

| | | |
|--|---|--|
| <p>SAFETY INSTRUCTIONS Read operating and safety manuals before using lift.</p> | <p>SAFETY INSTRUCTIONS Proper maintenance and inspection is necessary for safe operation.</p> | <p>If attachments, accessories or configuration modifying components that are located in the load path, affect operation of the lift, affect the lift electrical listing or affect intended vehicle accommodation are used on this lift and, if they are not certified for use on this lift, then the certification of this lift shall become null and void. Contact the participant for information pertaining to certified attachments, accessories or configuration modifying components.</p> <p>SAFETY INSTRUCTIONS</p> <p>load path, affect operation of the lift, affect the lift electrical listing or affect intended vehicle accommodation are used on this lift and, if they are not certified for use on this lift, then the certification of this lift shall become null and void. Contact the participant for information pertaining to certified attachments, accessories or configuration modifying components.</p> <p>www.autolift.org ©2007 by ALI, Inc. ALI/WLSIAO1</p> |
| <p>SAFETY INSTRUCTIONS Do not operate a damaged lift.</p> | <p>The messages and pictographs shown are generic in nature and are meant to generally represent hazards common to all automotive lifts regardless of specific style.</p> <p>Funding for the development and validation of these labels was provided by the Automotive Lift Institute, PO Box 33116 Indianapolis, FL 32903</p> <p>They are protected by copyright. Set of labels may be obtained from ALI or its member companies.</p> <p>© 1992 by ALI, Inc. ALI/WLSIAO1</p> | |

| | | | |
|--|--|--|--|
| <p>CAUTION Lift to be used by trained operator only.</p> | <p>CAUTION Authorized personnel only in lift area.</p> | <p>WARNING Clear area if vehicle is in danger of falling.</p> | <p>WARNING Position vehicle with center of gravity midway between adapters.</p> |
| <p>CAUTION Use vehicle manufacturer's lift points.</p> | <p>CAUTION Always use safety stands when removing or installing heavy components.</p> | <p>WARNING Remain clear of lift when raising or lowering vehicle.</p> | <p>WARNING Avoid excessive rocking of vehicle while on lift.</p> |
| <p>CAUTION Use height extenders when necessary to ensure good contact.</p> | <p>CAUTION Auxiliary adapters may reduce load capacity.</p> | <p>WARNING Do not override self-closing lift controls.</p> | <p>WARNING Keep feet clear of lift while lowering.</p> |
| <p>The messages and pictographs shown are generic in nature and are meant to generally represent hazards common to all automotive lifts regardless of specific style.</p> <p>Funding for the development and validation of these labels was provided by the Automotive Lift Institute, PO Box 33116 Indianapolis, FL 32903.</p> <p>They are protected by copyright. Set of labels may be obtained from ALI or its member companies.</p> <p>© 1992 by ALI, Inc. ALI/WLSIAO1</p> | | <p>The messages and pictographs shown are generic in nature and are meant to generally represent hazards common to all automotive lifts regardless of specific style.</p> <p>Funding for the development and validation of these labels was provided by the Automotive Lift Institute, PO Box 33116 Indianapolis, FL 32903.</p> <p>They are protected by copyright. Set of labels may be obtained from ALI or its member companies.</p> <p>© 1992 by ALI, Inc. ALI/WLSIAO1</p> | |

RECEIVING

The shipment should be thoroughly inspected as soon as it is received. The signed bill of lading is acknowledgement by the carrier of receipt in good condition of shipment covered by our invoice.

If any of the goods called for on this bill of lading are shorted or damaged, do not accept them until the carrier makes a notation on the freight bill of the shorted or damaged goods. Do this for your own protection.

NOTIFY **Quality Lifts** AT ONCE if any hidden loss or damage is discovered after receipt.

IT IS DIFFICULT TO COLLECT FOR LOSS OR DAMAGE AFTER YOU HAVE GIVEN THE CARRIER A CLEAR RECEIPT.

File your claim with **Quality Lifts** promptly. Support your claim with copies of the bill of lading, freight bill, and photographs, if available.

Component Packing List

| QTY/ LIFT | DESCRIPTION |
|-----------|-----------------------------|
| 1 | Power Column Assembly |
| 1 | Idler Column Assembly |
| 1 | Overhead Assembly |
| 1 | Hardware Box |
| 1 | Power Column Extension |
| 1 | Idler Column Extension |
| 2 | Rear Arm Assembly |
| 2 | Front Arm Assembly |
| 2 | Synchronizer Cable Assembly |
| 1 | Hydraulic Hose Pack |
| 1 | Power Lock Cover |
| 1 | Idler Lock Cover |

INSTALLATION

IMPORTANT: Always wear safety glasses while installing lift.

TOOLS (MINIMUM REQUIRED)

- a. Tape measure, 16ft
- b. Chalk line
- c. 4ft level
- d. 10" adjustable wrench
- e. Metric open end wrenches 10mm, 13mm, 14mm, 15mm, 17mm, 18mm, 19mm and 24mm
- f. Metric Allen Wrenches 4mm, 5mm, 6mm, and 8mm.
- g. Needle Nose pliers
- h. Snap Ring pliers
- i. Hammer drill with 3/4" diameter carbide tipped bits
- j. 2lb hammer
- k. Torque wrench: 150 foot pounds minimum with 1 1/8" socket
- l. 12 ft. Step ladder
- m. Anti-Seize lubricant (for arm pins and foot pad screw threads and stop rings)

LAYOUT

- 1) Layout the service bay according to the architect's plans or owners instructions (**see Fig 1b**). **Failure to install in this orientation can result in personal and property damage.** Be certain that the proper conditions exist, see page 3.
- 2) Assemble column extension to column using M12 x 30 Hex bolts. Repeat for opposite column and extension. Install power column extension on power column, see **Fig 6**.
- 3) Using the Overall Width (C) Dimension from **Fig 1b**, chalk two parallel lines on the floor within 1/8" tolerance. Erect both column assemblies. Align the base plate edges to the chalk lines.

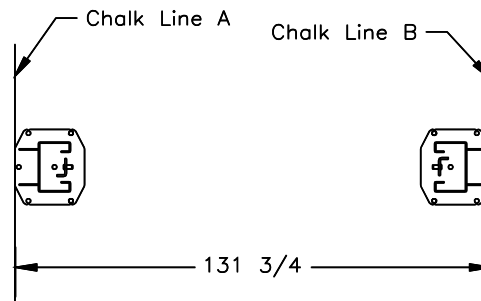

ANCHORING

- 4) The anchor bolts must be installed at least 8" from any crack, edge, or expansion joint.
- 5) Use a concrete hammer drill with a 3/4 inch carbide bit. Tip diameter should conform to ANSI Standard B94.12-1977 (.775 to .787). Do not use excessively worn bits or bits which have been incorrectly sharpened. A core bit may be necessary if an obstruction is encountered. **Never substitute with shorter anchor.**
- 6) Recheck "Inside of Columns" dimension, **Fig 1**. Drill the anchor holes using the base plate as a template. Drill through the floor if possible or to a depth of 5 inches minimum.
- 7) Vacuum dust from the hole for proper holding power.
- 8) Shim both columns to plumb using the shims provided as shown in **Fig 2**. DO NOT shim more than 1/2" at any given point. Use a level no less than 24" in length to plumb columns.
- 9) Assemble washer and nut to anchor with nut just below impact section of bolt. Drive anchor into hole until nut and washer contact base.

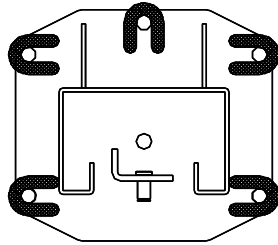

Fig 2 – Column Shimming

- 10) Tighten power column anchors and recheck column for plumb. Re-shim if necessary. Torque to 150 foot-pounds to set anchors.

OVERHEAD

- 11) Raise and install Overhead Assembly using M12 x 30 Hex Bolts.
- 12) Install Overhead Limit Switch under the Overhead Assembly on the Power Side. Route cable around outside of column as shown in **Fig. 6**.
- 13) Check idler column shimming. Use additional shims (**see Fig. 2**) to remove any gaps that may have been created while installing overhead beam. Tighten anchor bolts and recheck column for plumb. Torque to 150 foot-pounds.

SYNCHRONIZER CABLES

- 14) At the upper beam sheave locations disassemble and reassemble the cable trapping rod to install the cable onto the sheave, See **Fig 3**. To install the cable bottom sheave will need to be removed then reassembled.

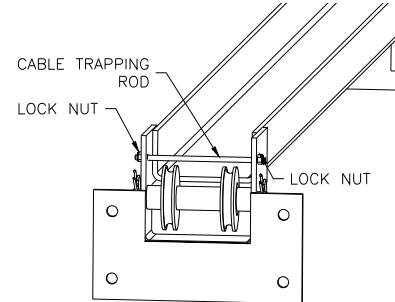

Fig 3-Cable Trapping

- 15) Attach one end of synchronizing cable to carriage. See **Fig 4** for proper attachment.
- 16) Route cable up and over sheave in overhead. Follow across to other sheave on opposite column. Route down through carriage to sheave in bottom of column. Route under sheave and up to cable attachment. Lower attachment point is used for Standard Height Installation (147 1/2") and the Upper attachment point is used for Reduced Height Installation (137 1/2"). Use **Fig 4** for proper attachment.
- 17) Repeat for opposite side.

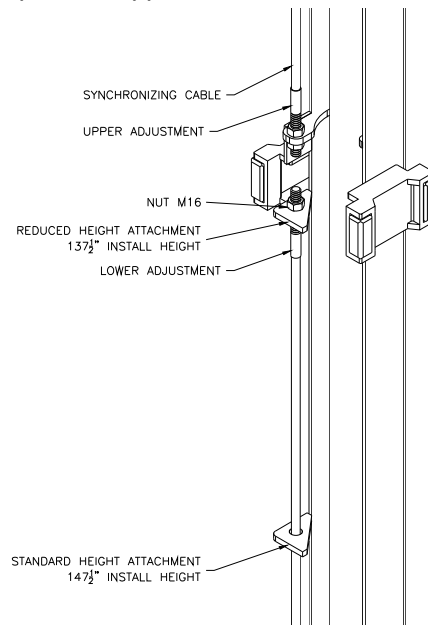

Fig 4 – Synchronizing Cables

POWER UNIT & HYDRAULIC LINES

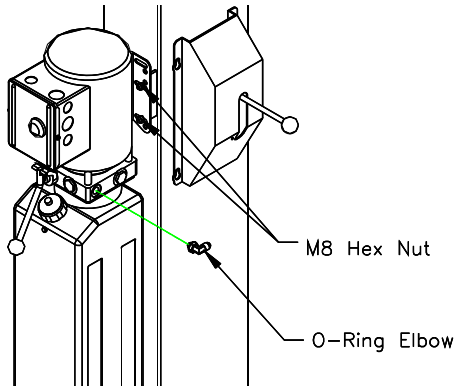

Fig 5 – Power Unit Mounting

- 18) Mount Power Unit to power column as shown in **Fig 5**. The mounting hardware, (4) M8 hex nuts, are pre-installed on power unit mounting bracket.
- 19) Attach Hydraulic elbow fitting threading the O-Ring end into the power unit.
- 20) **IMPORTANT – To insure proper hose fitting seal without damage to the fitting follow this procedure for each hose connection:** Screw flared fitting on finger tight. Rotate flared fitting 1 ½ flats or 90 degrees. Back the flared fitting off one full turn and repeat.
- 21) Thread power unit hose (short) to elbow in power on power unit.
- 22) Beginning on the idler side start with the Idler Extension hose at the elbow fitting (This hose has a male fitting on one end and is removed for reduced height installations). Continue with the Idler Column Hose (long) up the backside of the column through the two capture rings and guide at the top of the extension. Continue across the overhead through each of the guides as shown and down the backside of the power column. **See Fig 6.**

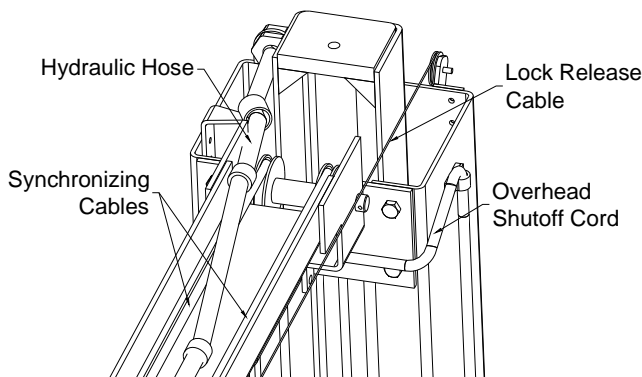

Fig 6 – Hose Routing (Power Side)

- 23) Route the remaining Power column hose beginning at the elbow fitting at the base up the backside of the column. Join the three hoses with the supplied union tee.
- 24) **BE CERTAIN ALL FITTINGS AND CONNECTIONS ARE TIGHT. IT IS THE INSTALLERS RESPONSIBILITY TO INSURE SYSTEM IS LEAK-FREE.** Fill the Power Unit with three gallons of clean 10wt anti-foam anti-rust hydraulic oil or Dexron III ATF. **Do NOT USE OILS WITH DETERGENTS.**

LOCK RELEASE

- 25) Install Lock Release Stud and Knob to the Power Column Lock using one M10 Nut.
- 26) Attach Mechanical Lock Release Cable Assembly to each lock pawl. **See Fig 7.**

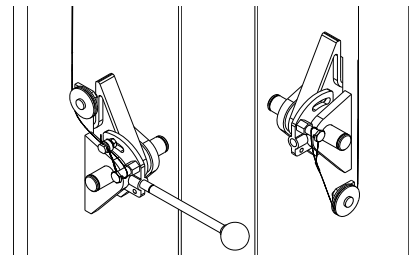

Fig 7 – Lock Assembly

THE LOCK RELEASE CABLE ADJUSTMENT IS NOT COMPLETE UNTIL THE LIFT HAS BEEN LOWERED AND “FINAL ADJUSTMENTS” HAVE BEEN MADE.

ARM INSTALLATION

- 27) Lubricate the arm pin or carriage arm pin hole with “anti-seize” and install the arms. Insure that the arm restraint gears engage and disengage properly. Arm restraints should disengage when lift is fully lowered. If any binding occurs, insure that the large gear mounted to the arm has been factory installed tight against the arm pin.
- 28) Extend the footpad to both extents and apply anti-seize to the three retaining rings and where the double screw makes contact with the base of the footpad.

ELECTRICAL

- 29) Refer to **Fig 8 Wiring Diagram** for all steps under this heading.

Single Phase

- 30) Connect the Overhead Limit Switch Cord to Power Unit as shown.
31) Connect Power Unit to suitable electrical source as shown.

Three Phase

- 32) Power unit is factory wired for 240 volt. Refer to wiring diagram or motor plate for optional voltages.
33) Connect Contactor Enclosure to column. Mounting hardware should be centered on the column side to side to avoid the path of the slide blocks.
34) Connect Overhead Limit Switch Cord to Contactor as shown.
35) Connect Contactor to Power unit as shown. Connect Contactor to suitable electrical source as shown.

IMPORTANT: AFTER WIRING HAS BEEN COMPLETED, TEST OPERATION OF POWER UNIT & OVERHEAD LIMIT SWITCH. WHILE RAISING LIFT, OPERATE OVERHEAD SHUTOFF BAR. POWER UNIT MOTOR SHOULD STOP WHEN SHUTOFF BAR IS RAISED.

FINAL ADJUSTMENTS

HYDRAULICS

- 36) Lower the lift to the floor and raise the lift approximately one foot.
37) Start with Idler side first. Slowly and carefully loosen the bleed plug on top side of the cylinder just enough to allow the entrapped air to escape. Repeat for power side.
38) Raise lift 6 inches. Repeat step 32 until no air comes out of cylinder.
39) Pressure test hydraulic system. Energize power unit, raise lift to full rise and continue to run motor for additional 10 seconds. (NOTE: pressure relief will make a high pitch squeal sound for these 10 seconds.) Check hydraulic system for leaks.
40) Energize power unit again for 10 seconds. With a clean rag, wipe down both cylinder rods. (The cylinders are shipped with a small amount of clear anti-corrosive lubricant that will be forced out through the wiper when the lift reaches full rise.) **If lubricant is not wiped clean from the cylinder rod, the cylinder will appear to be leaking.**

SYNCHRONIZING CABLES

- 41) Raise lift and insure carriages lower into same lock position.
42) Adjust synchronizing cables so the tension is equal in both cables and carriages are firmly sitting on locks.
43) Cycle lift to insure that latches operate simultaneously.

LOCK RELEASE CABLE

- 44) Raise lift to a lock position but don't set into the lock. Pull and release Power Column lock release handle while watching Idler Column lock. Adjust Cable tension by removing slack and retightening cable clamp at the power side. **IMPORTANT: IF IDLER SIDE LOCK PAWL DOES NOT FULLY DISENGAGE, DAMAGE MAY RESULT TO IDLER SIDE CARRIAGE AND OR CABLE SYNCHRONIZING SYSTEM.**
45) Remove lock release knob and install both covers. Replace lock release knob.

OWNER/OPERATOR CHECKLIST

- 46) Demonstrate the operation of the lift to the owner/operator and review correct and safe lifting procedures using the **Lifting It Right** booklet as a guide.
47) Complete the Installation Checklist/Warranty Validation questionnaire with the owner. Review the terms of the warranty registration card, and return the card and a copy of the questionnaires to:

QUALITY LIFTS, LLC
200 Cabel St., P.O. Box 3972,
Louisville, KY 40206

Wiring Diagram

EACH LIFT SHOULD HAVE A DEDICATED CIRCUIT WITH A DOUBLE POLE (THREE POLE FOR 440-480V) BREAKER OR TIME DELAY FUSE SIZED ACCORDING TO THE FOLLOWING CHART

| | 1 ϕ 208-240V | 3 ϕ 208V | 3 ϕ 220-240V | 3 ϕ 440-480V |
|-----|----------------------|------------------|----------------------|----------------------|
| 2Hp | 25amp | 15amp | 15amp | 5amp |

* WIRING MUST COMPLY WITH ALL LOCAL ELECTRICAL CODES *

FOR SINGLE PHASE

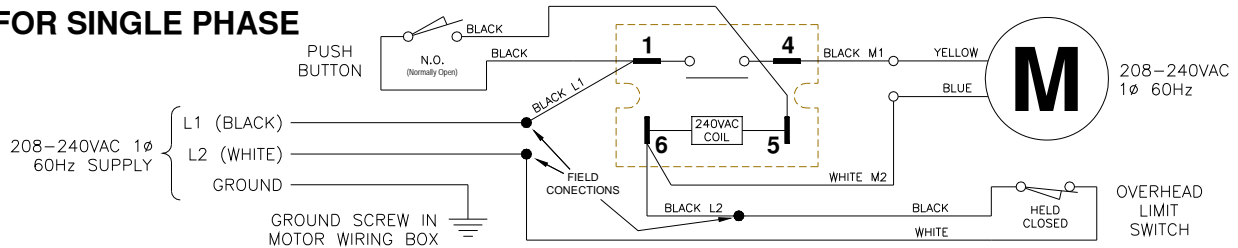

FOR THREE PHASE

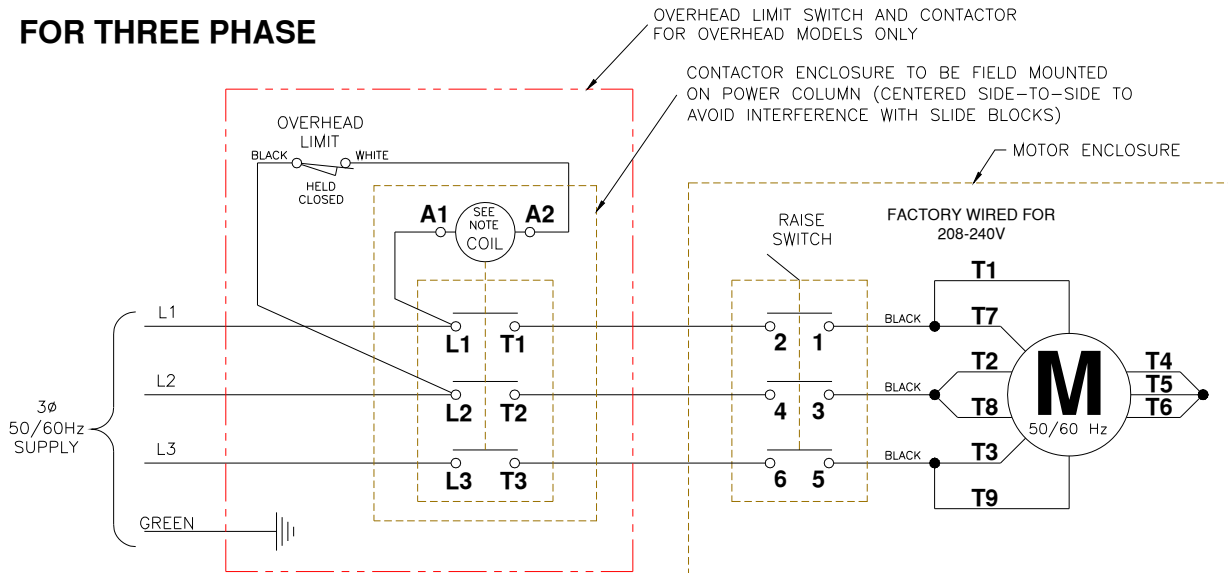

NOTES:

- 1) MOTOR IS FACTORY WIRED FOR 208V OR 220-240V SUPPLY
- 2) MOTOR CONNECTIONS MUST BE RECONFIGURED PER THIS DIAGRAM FOR 440-480V SUPPLY
- 3) CONTACTOR COIL RATING MUST MATCH SUPPLY VOLTAGE (208V, 220-240V, OR 440-480V)
- 4) CONTACTOR MUST BE FIELD MOUNTED ON POWER COLUMN (CENTERED SIDE-TO-SIDE TO AVOID INTERFERENCE WITH SLIDE BLOCKS)
- 5) MOTOR ROTATION IS COUNTER CLOCKWISE FROM TOP OF MOTOR

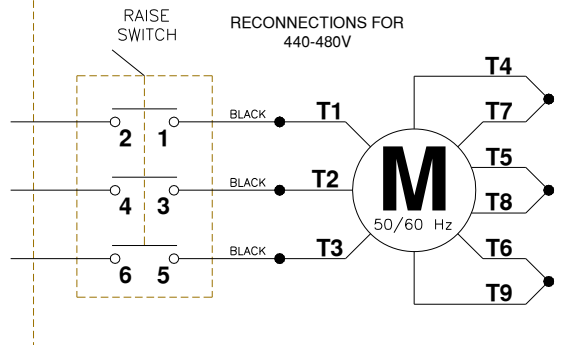

P/N 31366 1/05/02

Fig 8 – Electrical Wiring Diagram

OPERATION PROCEDURE

SAFETY NOTICES AND DECALS

This product is furnished with graphic safety warning labels, which are reproduced on page 3 of these instructions. Do not remove or deface these warning labels, or allow them to be removed or defaced. For your safety, and the safety of others, read and understand all of the safety notices and decals included.

OWNER/EMPLOYER RESPONSIBILITIES

This lift has been designed and constructed according to ANSI/ALI ALCTV-2006 standard. The standard applies to lift manufactures, as well as to owners and employers. The owner/employer's responsibilities as prescribed by ANSI/ALI ALOIM-2000, are summarized below. For exact wording refer to the actual standard provided with this manual in the literature pack.

The Owner/Employer shall insure that lift operators are qualified and that they are trained in the safe use and operation of the lift using the manufacturer's operating instructions; ALI/SM 93 -1, ALI Lifting it Right safety manual; ALI/ST-90 ALI Safety Tips card; ANSI/ALI ALOIM-2000, American National Standard for Automotive Lifts-Safety Requirements for Operation, Inspection and Maintenance; ALI/WL Series, ALI Uniform Warning Label Decals/Placards; and in case of frame engaging lifts, ALI/LP-GUIDE, Vehicle Lifting Points/Quick Reference Guide for Frame Engaging Lifts.

The Owner/Employer shall establish procedures to periodically inspect the lift in accordance with the lift manufacturer's instructions or ANSI/ALI ALOIM-2000, American National Standard for Automotive Lifts-Safety Requirements for Operation, Inspection and Maintenance; and the employer shall insure that the lift inspectors are qualified and that they are adequately trained in the inspection of the lift.

The Owner/Employer shall establish procedures to periodically maintain the lift in accordance with the lift manufacturer's instructions or ANSI/ALIOIM-2000, American National Standard for Automotive Lifts-Safety Requirements for Operation, Inspection and Maintenance; and the employer shall insure that the lift maintenance personnel are qualified and that they are adequately trained in the maintenance of the lift.

The Owner/Employer shall maintain the periodic inspection and maintenance records recommended by the manufacturer or ANSI/ALI ALOIM-2000, American National Standard for Automotive Lifts-Safety Requirements for Operation, Inspection and Maintenance.

The Owner/Employer shall display the lift manufacturer's operating instructions; ALI/SM 93 -1, ALI Lifting it Right safety manual; ALI/ST-90 ALI Safety Tips card; ANSI/ALI ALOIM-2000, American National Standard for Automotive Lifts-Safety Requirements for Operation, Inspection and Maintenance; and in the case of frame engaging lift, ALI/LP-GUIDE, Vehicle Lifting Points/Quick Reference Guide for Frame Engaging Lifts; in a conspicuous location in the lift area convenient to the operator.

IMPORTANT SAFETY INSTRUCTIONS

When using your garage equipment, basic safety precautions should always be followed, including the following:

1. Read all instructions.
2. Care must be taken as burns can occur from touching hot parts.
3. To reduce the risk of fire, do not operate equipment in the vicinity of open containers of flammable liquids (gasoline).
4. Keep hair, loose clothing, fingers, and all parts of body away from moving parts.
5. Use only as described in this manual. Use only manufacturer's recommended attachments.
6. ALWAYS WEAR SAFETY GLASSES. Everyday eyeglasses only have impact resistant lenses, they are not safety glasses.

SAVE THESE INSTRUCTIONS

LIFTING A VEHICLE

- 1) Insure that the lifting arms are parked, out to full drive thru position.
- 2) Position the vehicle in the service bay so that the vehicle's center of gravity is on a line between the two columns, and so the vehicle is centered between the two columns.

DO NOT EXCEED 2500 POUNDS PER ARM.

DO NOT ATTEMPT TO LIFT THE VEHICLE WITH ONLY TWO ARMS, AS THIS WILL VOID THE WARRANTY

INSURE THAT THE HIGHEST POINT ON THE VEHICLE WILL CONTACT THE OVERHEAD LIMIT SWITCH BAR.

DO NOT PLACE THE VEHICLE IN THE SERVICE BAY BACKWARDS.

REFER TO THE VEHICLE MANUFACTURERS SERVICE MANUAL, TECHNICAL BULLETINS, "VEHICLE LIFTING POINTS GUIDE" (ALI/LP-GUIDE) OR OTHER PUBLICATIONS TO LOCATE THE RECOMMENDED LIFTING POINTS.

- 3) Position the arms and adapters so all four pads contact the vehicle simultaneously.

The vehicle should remain level during lifting.

- 4) Raise the lift until all four wheels are off the ground. Test the stability of the vehicle by attempting to rock the vehicle. Check adapters for secure contact with vehicle lift points. If the vehicle seems unstable, lower the lift and readjust the arms. If the vehicle is stable, raise the vehicle to a height a few inches above the desired working height.
- 5) Lower the vehicle until the safety latches on both columns engage. The vehicle should remain level when both latches are engaged. If one side engages and the other continues to descend, stop lowering the vehicle, raise it several inches, and try again to engage both latches.

Always lower lift into locks before entering the area beneath the vehicle.

Always use safety stands when removing or installing heavy components.

LOWERING A VEHICLE

- 1) Insure that the area under the vehicle is clear of personnel and tools.
- 2) Raise the vehicle until both latches are free.
- 3) Disengage the latches by pulling down and holding the lock release lever.
- 4) Lower the vehicle by depressing the lowering valve handle.
- 5) Continue to lower the vehicle until the carriages stop against the base plate. Retract the extension arms, and park them.

MAINTENANCE

To avoid personal injury, permit only qualified personnel to perform maintenance on this equipment. Maintenance personnel should follow lockout/tagout instructions per ANSI Z244.1.

The following maintenance points are suggested as the basis of a preventive maintenance program. The actual maintenance program should be tailored to the installation. See ANSI/ALI ALOIM booklet for periodic inspection checklist and maintenance log sheet.

- If lift stops short of full rise or chatters, check fluid level and bleed both cylinders per Installation Instructions.
- Replace all Safety, Warning or Caution Labels if missing or damaged (**See Installation instructions page 3.**)

Daily

- Keep lift components clean.
- Check for loose or broken parts.
- Check hydraulic system for fluid leaks.
- Check adapters for damage or excessive wear. Replace as required with genuine Quality Lifts parts.
- Check lock release activation. When properly adjusted, the idler column lock should rest firmly against the back of the column when engaged and pull clear of the column back when disengaged.

Weekly

- Check synchronizer cables and sheaves for wear. Replace as required with genuine Quality Lifts parts.
- Check lock release cable adjustment per Installation Instructions step 39.

IMPORTANT: IF IDLER SIDE LOCK PAWL DOES NOT FULLY DISENGAGE, DAMAGE MAY RESULT TO IDLER SIDE CARRIAGE AND OR CABLE SYNCHRONIZING SYSTEM.

- Check synchronizer cable tension per Installation Instructions. Adjust if necessary.

Monthly

- Torque concrete anchor bolts to 80 ft-lbs.
- Check overhead shutoff switch. While raising lift, operate overhead shutoff bar. Power Unit motor should stop when bar is raised.
- Lubricate carriage slide tracks with heavy viscous grease. (Grease all (4) corners of both columns.)
- Visually inspect concrete floor for cracks and/or spalls within 12" of base plate

If any problems are encountered, contact your local service representative.

Parts Breakdown

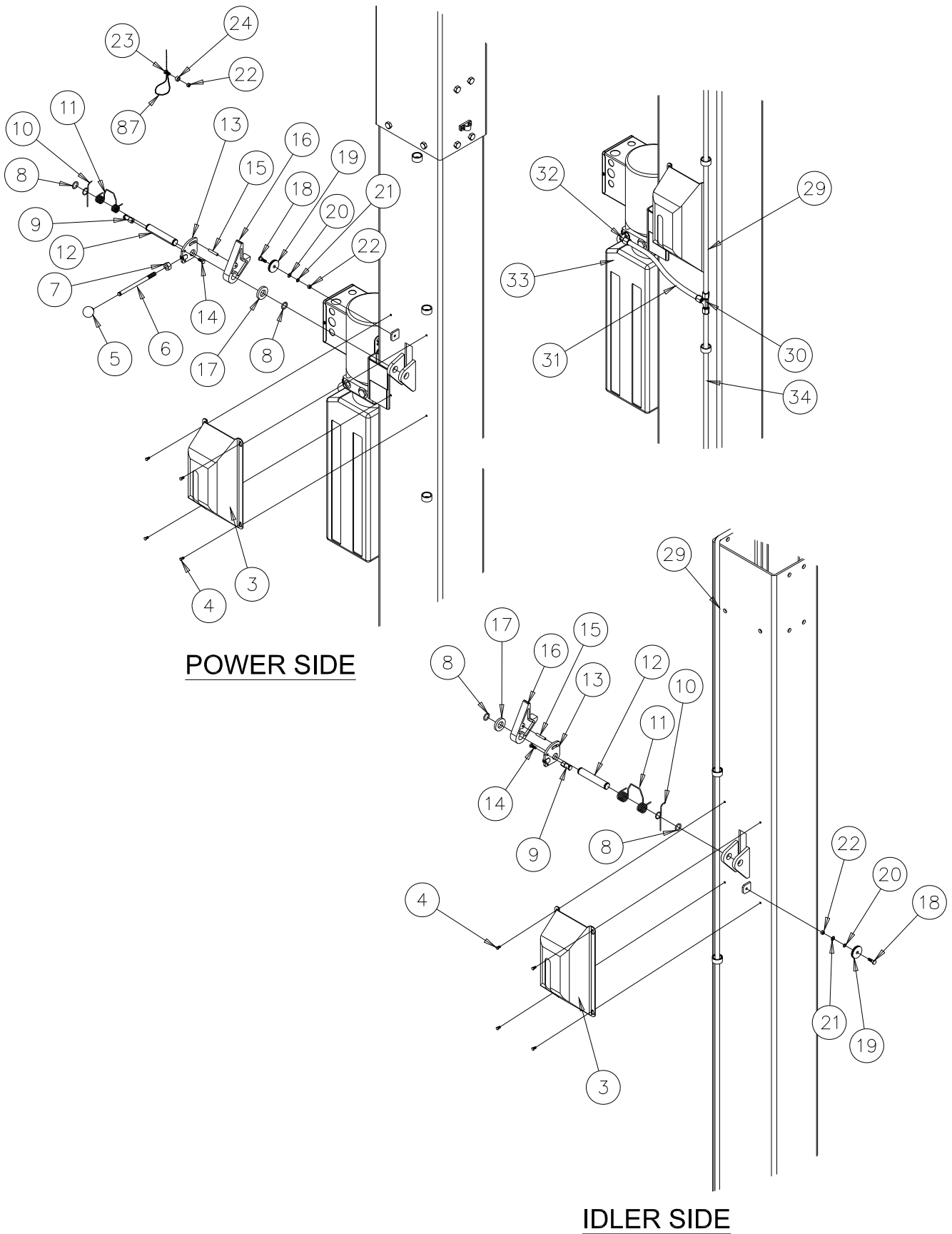

Model Q10
 Installation, Operation and Maintenance

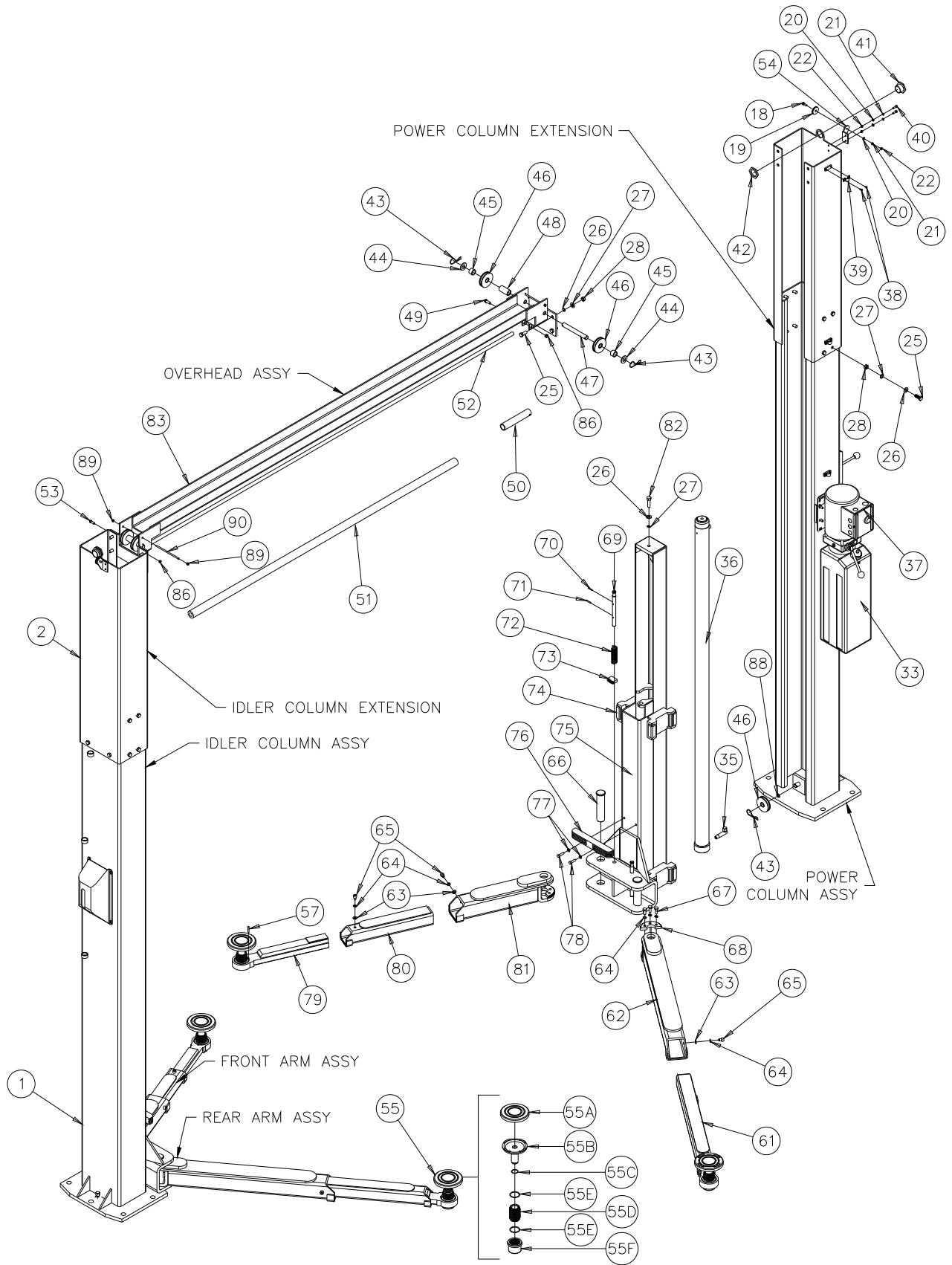

Model Q10
Installation, Operation and Maintenance

| Item # | Part # | Qty. | Description | Item # | Part # | Qty. | Description |
|--------|-----------------|------|--------------------------|--------|------------------|-------|------------------------|
| 1 | JSJ5-02-01-00 | 1 | Power Column Weld | 45 | X10-056 | 4 | Spacer Sleeve |
| | JSJ5-02-01-00f | 1 | Idler Column Weld | 46 | X10-057 | 6 | Synch. Sheave |
| 2 | JSJ5-02-02-00Q | 1 | Power Extension Weld | 47 | X10-058 | 2 | Axle |
| | JSJ5-02-02-00fQ | 1 | Idler Extension Weld | 48 | X10-059 | 2 | Middle Spacer Sleeve |
| 3 | X10-013 | 1 | Power Lock Cover | 49 | X10-060 | 2 | Bolt M8 x 25 |
| | X10-014 | 1 | Idler Lock Cover | 50 | 36027 | 1 | Limit Switch |
| 4 | X10-065 | 8 | Screw M5 x10 | 51 | JSJ5-03-03Q | 1 | Shutoff Bar Cushion |
| 5 | X10-017 | 1 | Lock Release Knob | 52 | JSJ5-03-02Q | 1 | Shutoff Bar |
| 6 | X10-018 | 1 | Lock Release Stud | 53 | X10-063 | 1 | Bolt M8 |
| 7 | X10-019 | 1 | Nut M10 | 54 | JSJ4-02-11-00 | 1R/1L | Pulley Bracket |
| 8 | X10-020 | 4 | "C" Ring 20 | 55 | B2250 | 4 | Foot Pad Assembly |
| 9 | X10-021 | 2 | Lock Release Wire Pin | 55A | B2208 | 4 | Rubber Insert |
| 10 | X10-022 | 2 | Lock Release Spring 1 | 55B | B2205 | 4 | Foot Pad Weld |
| 11 | X10-023 | 2 | Lock Release Spring 2 | 55C | B17256 | 4 | 2x30 Retaining Ring |
| 12 | X10-024 | 2 | Lock Release Shaft | 55D | B17254 | 4 | Threaded Sleeve |
| 13 | X10-025 | 2 | Lock Release Cam | 55E | B2250 | 8 | 3x45 Retaining Ring |
| 14 | X10-026 | 2 | Bolt M6 | 55F | B17276-1 | 4 | Threaded Insert |
| 15 | X10-027 | 2 | Spring Pin 6 x 35 | 57 | B2211 | 4 | Roll Pin, ø6x30 |
| 16 | X10-028 | 2 | Lock Pawl | 61 | JSJ5B-09-02-00CH | 2 | Rear Male Arm |
| 17 | X10-029 | 2 | Washer | 62 | JSJ5B-09-01-00B | 2 | Rear Female Arm |
| 18 | X10-030 | 4 | Pulley Axle | 63 | X10-073 | 6 | Washer 10mm |
| 19 | X10-031 | 4 | Pulley | 64 | X10-074 | 18 | Spring Washer 10mm |
| 20 | X10-032 | 8 | Washer 6mm | 65 | X10-075 | 6 | Screw M10 |
| 21 | X10-033 | 8 | Spring Washer 6mm | 66 | X10-076 | 4 | Arm Pin |
| 22 | X10-034 | 9 | Nut M6 | 67 | X10-077 | 12 | Screw M10 x 25 |
| 23 | X10-035 | 1 | Bolt (Cable Clamp) | 68 | X10-078 | 4 | Inner Gear |
| 24 | X10-036 | 1 | Sleeve | 69 | JSJ5-13Q | 4 | Arm Restraint Pin |
| 25 | X10-037 | 28 | Bolt M12 x 30 | 70 | X10-080 | 4 | Spring Pin 4 x 24 |
| 26 | X10-038 | 28 | Washer 12mm | 71 | X10-081 | 4 | Spring Pin 4 x 30 |
| 27 | X10-039 | 28 | Spring Washer 12mm | 72 | X10-082 | 4 | Arm Restraint Spring |
| 28 | X10-040 | 28 | Nut M12 | 73 | X10-083 | 4 | Outer Gear |
| 29 | JSJ5-18Q | 1 | Idler Column Hose | 74 | X10-084 | 16 | Slide Block |
| 29a | JSJ5-21Q | 1 | Idler Extension Hose | 75 | JSJ5-08-00Q | 2 | Carriage |
| 30 | X10-042 | 1 | Union Tee | 76 | X10-086 | 2 | Door Guard |
| 31 | X10-043 | 1 | Power Unit Hose | 77 | X10-087 | 4 | Washer 8mm |
| 32 | X10-044 | 1 | O-Ring Elbow | 78 | X10-088 | 4 | Bolt M8 x 30 |
| 33 | 31368-21 | 1 | Power Unit | 79 | JSJ5B-10-03-00CH | 2 | Front Male Arm |
| 34 | X10-045 | 1 | Power Column Hose | 80 | JSJ5B-10-02-00 | 2 | Front Intermediate Arm |
| 35 | X10-046 | 2 | Long Elbow | 81 | JSJ5B-10-01-00 | 2 | Front Female Arm |
| 36 | X10-047 | 2 | Cylinder | 82 | X10-092 | 2 | Bolt M12 x 45 |
| 37 | X10-048 | 4 | Nut M8 | 83 | JSJ5-03-01-00Q | 1 | Overhead Weld |
| 38 | X10-049 | 10 | Bolt M5 x 8 | 84 | JSJ5-04-00Q | 2 | Synchronizing Cable |
| 39 | X10-050 | 5 | Plate-Shutoff Cord Clamp | 85 | X10-095 | 6 | Nut M16 |
| 40 | X10-051 | 4 | Bolt M6 x 20 | 86 | X10-096 | 2 | Lock Nut M10 |
| 41 | X10-052 | 2 | Hose Guide | 87 | X10-097 | 1 | Lock Release Cable |
| 42 | X10-053 | 2 | Hose Guide Nut | 88 | X10-099 | 4 | Washer 20mm |
| 43 | X10-054 | 6 | Hair Pin Cotter | 89 | B31061 | 4 | M6 Lock Nut |
| 44 | X10-055 | 4 | Washer | 90 | JSJ5-03-07ch | 2 | Cable Trapping Rod |

IMPORTANT

Replace all worn or broken parts with **genuine Quality Lifts parts**. Contact your local Quality Lifts parts distributor for pricing and availability. Call Quality Lifts, Inc. at **(502) 583-5438** for the distributor in your area.