

2021 Admiral Heights Improvement Association (AHIA)

Spring Membership Meeting

March 2, 2021

Held On-Line





Agenda

- President's Welcome – Scott Gibson
- Administrative Items
 - Approval of Minutes* – Cindy Radulovich
 - Treasurer's Report – John Leupold
- Presentation on Walkability/Cedar Park Road Sidewalk
 - Sam Brice, Chief of Engineering and Construction
 - Jennifer Feight, Project Manager
- Community Survey Results – Joe Flasher
- Proposed Capital Investments – Grant Garcia and Lizzie Coelho
- Board Elections – Scott Gibson
- Updates from City Hall - Alderman Paone

*Minutes posted on our website.



President's Welcome – WE have done a lot!



New racks @ Dewey & new dock @ Williams.

New Scarecrow Making Event.



Socially distant Santa Visits.

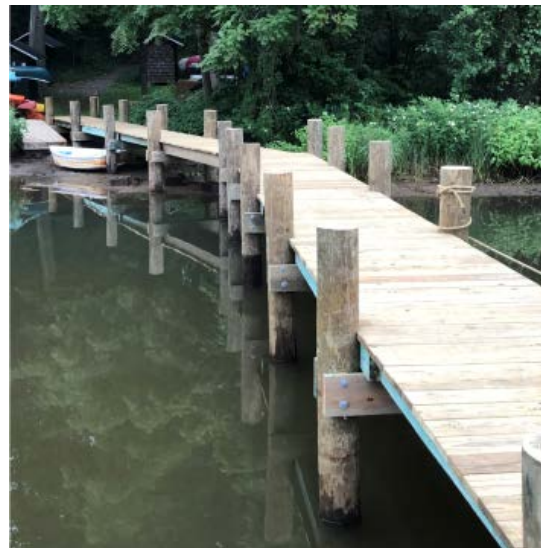

Got Cedar Park Sidewalk in City's Capital Budget



Approval of Minutes

- Available at: <http://www.admiralheights.org/ahia-board.html> (Select October 2020 hyperlink)
- Seeking approval by unanimous consent.
- If a member in good standing objects, they can:
 - enter their objection in the chat, or
 - file their objection by e-mail to President@AdmiralHeights.org dated prior to March 3 at 7 PM.



Treasurer's report

- Key points

- So far 122 Neighbors have paid 2021 Dues!
- We are currently on track for our “better case” budget
- You can now sign up to have your dues auto-renew.
- We have renewed the landscaping contract adding more service for maintaining the gardens around the neighborhood signs and the traffic circle garden.
- 2020 Ended with a Surplus
 - Social events costs were DOWN due to COVID.
 - Property Expenses were UP – new dock at Williams, new kayak racks, trees had to be removed, etc.

- Annual Dues:
\$40
- Kayak Rack
Lease Rate:
\$45

Thank You Members for Supporting AHIA!!!

Admiral Heights Improvement Association

Profit and Loss Budget Performance

January through February 28, 2021



Treasurer's report

Admiral Heights Improvement Association

Balance Sheet

As of February 28, 2021

ASSETS

Current Assets

Checking/Savings

| | |
|------------------------|-------------|
| Certificate of Deposit | \$5,183.69 |
| Dock Rebuild Checking | \$1,287.90 |
| General Checking | \$19,723.93 |

Total Assets

\$26,195.52

| | Current | Budget | Remainder |
|----------------------------|--------------------|---------------------|----------------------|
| Income | | | |
| Advertising 2020 | \$ 729.34 | \$ 250.00 | \$ (479.34) |
| AHIA Dues 2021 | \$ 4,856.34 | \$ 8,000.00 | \$ 3,143.66 |
| Boat Club Lease | \$ - | \$ 1.00 | \$ 1.00 |
| Boat Rack Rental 2021 | \$ 567.11 | \$ 1,440.00 | \$ 872.89 |
| Donations 2021 | \$ 180.00 | \$ - | \$ (180.00) |
| Dock Donations 2021 | \$ - | \$ - | \$ - |
| Dock Fund Contribution | \$ - | \$ 750.00 | \$ 750.00 |
| Total Income | \$ 6,332.79 | \$ 10,441.00 | \$ 4,108.21 |
| Expense | | | |
| BGE | \$ 33.57 | \$ 250.00 | \$ 216.43 |
| Bike Parade | \$ - | \$ 100.00 | \$ 100.00 |
| Block Party | \$ - | \$ - | \$ - |
| Dock Donations (into fund) | \$ - | \$ - | \$ - |
| Dock Replacement Fund | \$ - | \$ 1,500.00 | \$ 1,500.00 |
| Easter Egg Hunt | \$ - | \$ 100.00 | \$ 100.00 |
| Facilities Maintenance | \$ - | \$ 500.00 | \$ 500.00 |
| Greenscape | \$ - | \$ - | \$ - |
| Halloween | \$ - | \$ - | \$ - |
| Insurance | \$ - | \$ 3,500.00 | \$ 3,500.00 |
| Internet | \$ 239.88 | \$ 275.00 | \$ 35.12 |
| Memberships | \$ - | \$ - | \$ - |
| Membership Mailings | \$ - | \$ 400.00 | \$ 400.00 |
| Mowing | \$ - | \$ 3,000.00 | \$ 3,000.00 |
| Office Supplies | \$ - | \$ 100.00 | \$ 100.00 |
| PO Box Rental | \$ - | \$ 100.00 | \$ 100.00 |
| Printing - Newsletter | \$ - | \$ 600.00 | \$ 600.00 |
| Santa Visit | \$ - | \$ - | \$ - |
| Yard Sale | \$ - | \$ - | \$ - |
| Total Expense | \$ 273.45 | \$ 10,425.00 | \$ 10,151.55 |
| Net Income | \$ 6,059.34 | \$ 16.00 | \$ (6,043.34) |



Cedar Park Road Sidewalk

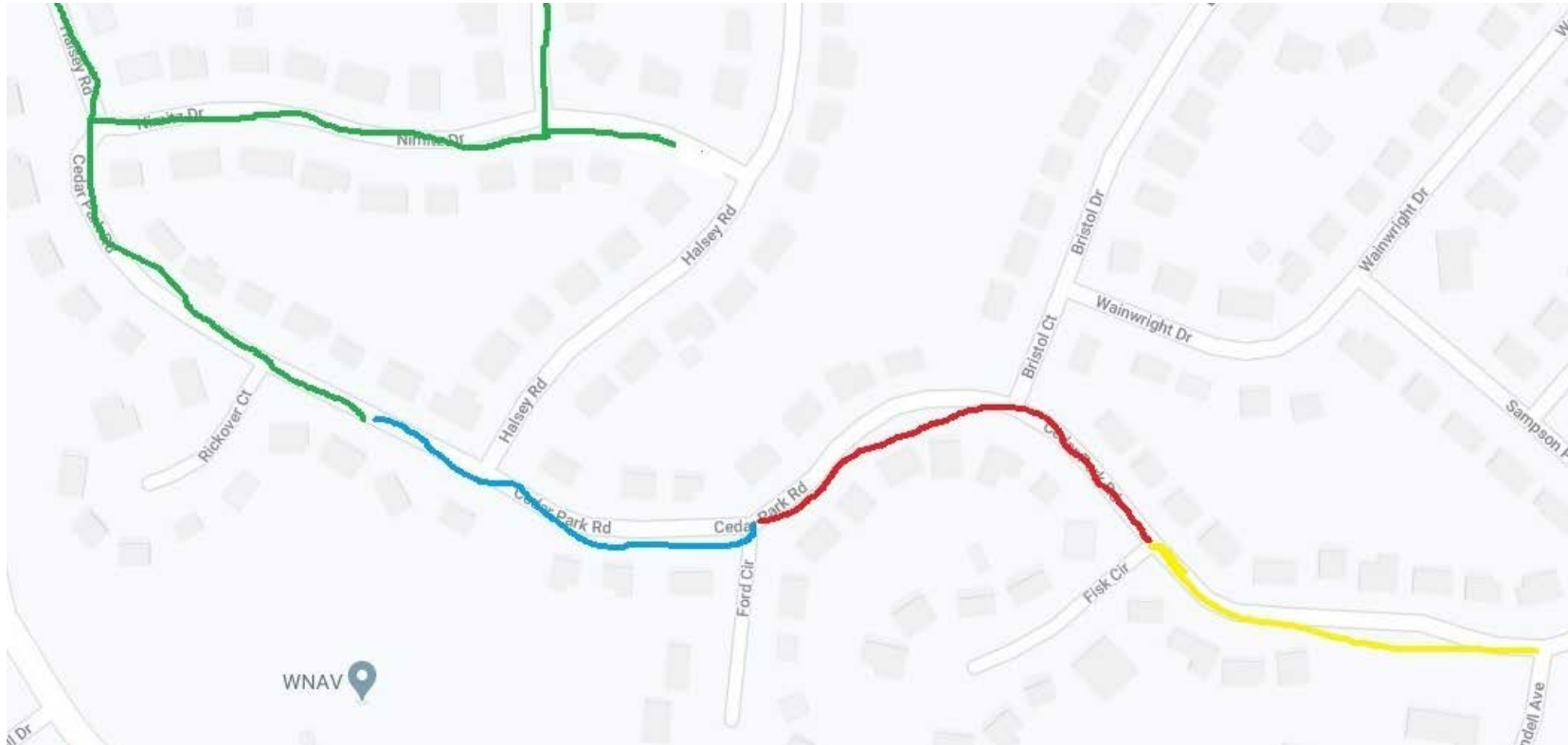

Planned first phase is a pilot using material from prior bike lane experiments.

Green reflects existing sidewalk. Blue, Red and Yellow are blocks needing sidewalk to connect to existing sidewalk infrastructure.

Cedar Park Sidewalks



General Scope:

- Provide a sidewalk connection from existing sidewalk to Windell Avenue (Approx. 1800LF)
- Temporary sidewalk/walkway and no parking signs placed in April 2021.
- Sidewalk will be 5' wide extending from existing curb line into Cedar Park drive

General Details

- Parking will be removed on Cedar Park Road adjacent to proposed sidewalk.
- The temporary walkway will remain until permanent installation is completed.
- The project will include new driveway aprons and minor driveway adjustments.
- ADA truncated domes will be placed at every street crossing.
- Storm drain inspection and adjustments will be made to accommodate storm water management practices and new curb line.

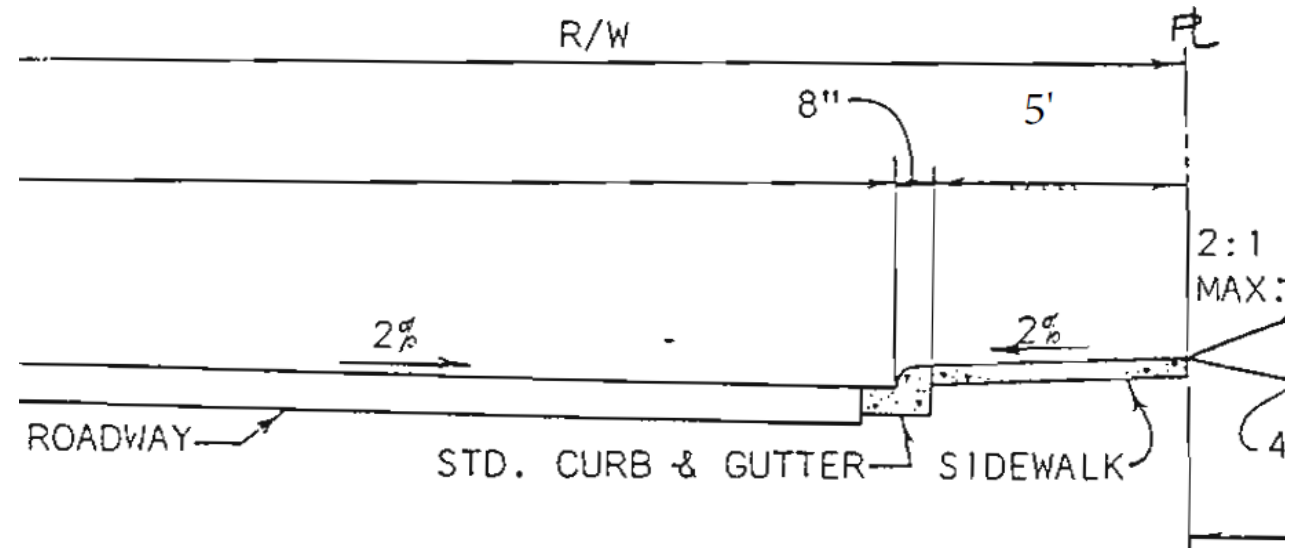



Community Survey Results

47 respondents to the first ever Community Survey, thank you!

- Primary concerns?
 - *Upkeep and beautification of community properties* most popular by far
- Project interest?
 - *Appearance of Porter Rd circle, Halsey Park playground, information sign*
- What is AHIA doing that you think we should continue doing?
 - Communicating well, getting feedback, virtual meetings, interface to city
- What is AHIA **not** doing that you think we should start doing?
 - Traffic calming, walkability, more social options and online interactions



Proposed Capital Investments - \$7,500

Dewey Dock Re-decking

- Replace existing decking.
- Project will fix the problem with loose and splintered boards.

Cedar Park Sign Park Improvement

- Improved landscaping.
- Add benches and Little Free Library.
- Add informational sign if permitted by code.





Board Elections

Ballot is available at:

- <http://bit.ly/ahia-2021-board-ballot>

Please cast ballots by Wednesday, March 3 at 7:00PM

Results will be announced on Monday, March 8 on FB and Website.

2020 Officers are automatically re-elected to the Board per By-laws.



Updates from City Hall

- Alderman Fred Paone



Upcoming AHIA Event

GREENSCAPE

Sunday, April 24, 9 a.m.

Dewey Dock.

Tasks including removal of invasive ivy and planting some trees, shrubs and perennials.

Bring trowels, shovels, gloves and rakes.

Please wear masks.