

Optimizing the lifetime of MANET by designing a Co-operative MAC protocol

Shruthi Venkata Bhavaraju¹, Abhilash Vanam²

¹*Mahatma Gandhi Institute of Technology, Gandipet Main Rd, Kokapet, Hyderabad, Telangana 500075*

²*Mahatma Gandhi Institute of Technology, Gandipet Main Rd, Kokapet, Hyderabad, Telangana 500075*

(¹*shruthi.bhavaraju@gmail.com*, ²*abhilash.vanam4913@gmail.com*)

Abstract-MANET (Mobile Ad-Hoc Network) has a dynamic topology. Due to the mobility of nodes in the network of cooperative communication is a technique for archived greater efficiency of transmission. In this paper the Network Lifetime has been improved using Cross layer Distributed Energy Adaptive Location based Cooperative MAC protocols. This DEL-CMAC protocol has been increases the network lifetime and energy efficiency. The performance is achieved by utility based best relay selection strategy selects the best relay used on location information and residual energy. In this proposed work significantly improves the network lifetime even in high circuitry energy consumption in more cases.

Keywords-MANET; Network Lifetime; MAC protocols; energy consumption.

I. INTRODUCTION

An ad-hoc network is a collection of wireless mobile hosts forming a temporary network without the aid of any stand-alone infrastructure or centralized administration. Mobile Ad-hoc networks are self-organizing and self-re-configuring multi-hop wireless networks where, the structure of the network changes dynamically. This is mainly due to the mobility of the nodes. Nodes in these networks utilize the same random access wireless channel, cooperating in a friendly manner to engaging themselves in multi-hop forwarding. The nodes in the network not only act as hosts but also as routers that route data to/from other nodes in network. In mobile ad-hoc networks where there is no infrastructure support as is the case with wireless networks, and since a destination node might be out of range of a source node transmitting packets; a routing procedure is always needed to find a path so as to forward the packets appropriately between the source and the destination. Within a cell, a base station can reach all mobile nodes without routing via broadcast in common wireless networks. In the case of ad-hoc networks, each node must be able to forward data for other nodes. This creates additional problems along with the problems of dynamic topology which is unpredictable connectivity changes.

MANETS rely on wireless transmission, a secured way of message transmission is important to protect the privacy of the data. An insecure ad-hoc network at the edge of an existing communication infrastructure may potentially cause the entire network to become vulnerable to security breaches. In mobile ad hoc networks, there is no central administration to take care of detection and prevention of anomalies.

Mobile devices identities or their intentions cannot be predetermined or verified. Therefore nodes have to cooperate for the integrity of the operation of the network. However, nodes may refuse to cooperate by not forwarding packets for others for selfish reasons and not want to exhaust their resources. Various other factors make the task of secure communication in ad hoc wireless networks difficult include the mobility of the nodes, a promiscuous mode of operation, limited processing power, and limited availability of resources such as battery power, bandwidth and memory. Therefore nodes have to cooperate for the integrity of the operation of the network. Nodes may refuse to cooperate by not forwarding packets for others for selfish reasons and not want to exhaust their resources.

In ad hoc networks devices (also called nodes) act both as computers and routers. Most routing protocols lead nodes to exchange network topology information in order to establish communication routes. This information is sensitive and may become a target for malicious adversaries who intend to attack the network or the applications running on it.

There are two sources of threats to routing protocols. The first comes from external attackers. By injecting erroneous routing information, replaying old routing information, or distorting routing information, an attacker could successfully partition a network or introduce a traffic overload by causing retransmission and inefficient routing. The second and more severe kind of threat comes from compromised nodes, which might (i) misuse routing information to other nodes or (ii) act on applicative data in order to induce service failures.

The provision of systematic approaches to evaluate the impact of such threats on particular routing protocols remains an open challenge today. Attacks on ad hoc are classified into non disruptive passive attacks and disruptive active attacks. The active attacks are further classified into internal attacks and

external attacks are carried out by nodes that do not belong to network and can be prevented by firewalls and encryption techniques. Internal attacks are from internal nodes which are actually authorized nodes and part of the network hence it is difficult to identify.

II. LITERATURE SURVEY

The paper [1] presents RAP, new real-time communication architecture for large-scale sensor networks. Author proposes Velocity Monotonic Scheduling (VMS). VMS assigns the priority of a packet based on its requested velocity. A packet with a higher requested velocity is assigned a higher priority. VMS improves the number of packets that meet their deadlines because it assigns the “right” priorities to packets based on their urgencies on the current hop. But there is no detail for packet arrival distance. And in this paper, when the queue is full, higher priority incoming packets overwrite lower priority ones. It may be a problem to be the low priority information.

In this paper [2], author proposed an Adaptive Staggered SLEEP Protocol (ASLEEP) for efficient power management in wireless sensor networks targeted to periodic data acquisition. This protocol dynamically adjusts the sleep schedules of nodes to match the network demands, even in time-varying operating conditions. It uses the CSMA scheme for processing the data, but it may be not efficient in fixed WSN network and there is no detail to data management.

In this paper [3], author presents how to place sensors by use of a minimal number to maximize the coverage area when the communication radius of the SN is not less than the sensing radius, which results in the application of regular topology to WSN deployment. In this paper author discussed the details of sensor deployment. Due to optimal coverage sensor deployment, it reduces the number of sensors usage and also increases the lifetime of sensors. But till lifetime of sensor need to increase.

In this paper [4], author proposed a clustering method with coverage and energy aware TDMA scheduling scheme. And the cluster formation is done by the base station according to the current residual energy, and the coverage area of cluster Member is reduced to avoid the congestion and energy management. In this paper also there is no discussion on the real time and non-real time packet scheduling.

Author developed scheme by designing the network with multiple-sized fixed grids while taking into account the arbitrary-shaped area sensed by the sensor nodes. In this paper [5], author considers the different initial energy level of sensors, and placed that sensor according to that energy level. So energy loss was avoided. But calculating different initial energy level and placing the node according to that energy level is difficult in real time.

In this paper [6] author present a cluster based routing algorithm. One of author’s main goals is to design the energy efficient routing protocol. This algorithm makes the best use of node with low number of cluster head known as super node. Here author divided the full region in equal zones and the center area of the region is used to select for super node. Each zone is considered separately and the zone may be or not divided further that’s depending upon the density of nodes in that zone and capability of the super node. In this paper author considered, cluster head changes when the cluster head is failed. It may be the problem to sensing in that area.

In this paper [7] author investigate the usefulness of enforcing a minimum separation distance between cluster heads in a cluster based sensor network, thereby prolonging network lifetime by spreading the cluster heads, thus lowering the average communication energy consumption. In this paper, author consider the minimum separation distance between cluster heads in a cluster based sensor network, thereby prolonging network lifetime by spreading the cluster heads and it shows that our sensor network performs up to 150% better when introducing a minimum separation distance between cluster heads, comparing the number of messages received at the base station, the author consider only about the distance between the cluster heads to improve network lifetime but not energy levels.

Author proposed [8] the two centralized heuristic algorithms: one based on direct node-based scheduling, which is adapted from classical multi-hop scheduling algorithms for general ad hoc networks, and the other based on scheduling the levels in the routing tree before scheduling the nodes, which is a novel scheduling algorithm for many-to-one communication in sensor networks.

III. SYSTEM ANALYSIS

A. *Feasibility study*:-Preliminary investigation examine project feasibility, the likelihood the system will be useful to the organization. The main objective of the feasibility study is to test the Technical, Operational and Economical feasibility for adding new modules and debugging old running system. All system is feasible if they are unlimited resources and infinite time. There are aspects in the feasibility study portion of the preliminary investigation:

- 1) Technical Feasibility
- 2) Operational Feasibility
- 3) Economical Feasibility

1) *Technical Feasibility*:- Think of the technical feasibility study as the logistical or tactical plan of how your business will produce, store, deliver, and track its products or services. A technical

feasibility study is an excellent tool for troubleshooting and long-term planning.

- 2) **Operational Feasibility:-** Operational feasibility is the measure of how well a proposed system solves the problems, and takes advantage of the opportunities identified during scope definition and how it satisfies the requirements identified in the requirements analysis phase of system development.
- 3) **Economic Feasibility:-** The purpose of an economic feasibility study (EFS) is to demonstrate the net benefit of a proposed project for accepting or disbursing electronic funds/benefits, taking into consideration the benefits and costs to the agency, other state agencies, and the general public as a whole.

B. Modules

- 1) Route Discovery
- 2) Virtual Clustering
- 3) Data Transmission
- 4) Power Saving

1) Route Discovery:-

- 1. Here we are going to enable the timer to send hello message in regular intervals.
- 2. Hello message is to know about the neighbour nodes, based on the reply we got we will store the neighbour table information.
- 3. In every regular interval it's going to update the routing table based on the hello message.

2) Virtual Clustering:-

- 1. After updating the information and finding neighbour nodes they are going to generate SYNC message.
- 2. This SYNC message is to avoid the collision.
- 3. Based on SYNC message slots will be allocated.

3) Power Saving:-

- a) The SLEEP SCHEDULING uses Request-To-Send, Clear-To-send handshakes with methods for adapting the transmit power to the minimum level necessary to reach the intended neighbor.
- b) Thus, the SLEEP SCHEDULING reduces energy consumption by suitably varying the transmit power.

4) Data Transmission:-

- 1. According to the power control method and in the allocated slots based on SYNC method, sensors are going to transmit the data and similarly they will shift to sleep mode when there is no need to transmit the data.

IV. SYSTEM DESIGN

The purpose of the design phase is to plan a solution of the problem specified by the requirement document. This phase is the first step in moving from the problem domain to the solution domain. In other words, starting with what is needed; design takes us toward how to satisfy the needs. The design of a system is perhaps the most critical factor affecting the quality of the software; it has a major impact on the later phase, particularly testing, maintenance. The output of this phase is the design document. This document is similar to a blueprint for the solution and is used later during implementation, testing and maintenance. The design activity is often divided into two separate phases System Design and Detailed Design.

System Design also called top-level design aims to identify the modules that should be in the system, the specifications of these modules, and how they interact with each other to produce the desired results. At the end of the system design all the major data structures, file formats, output formats, and the major modules in the system and their specifications are decided.

SYSTEM ARCHITECTURE DIAGRAM

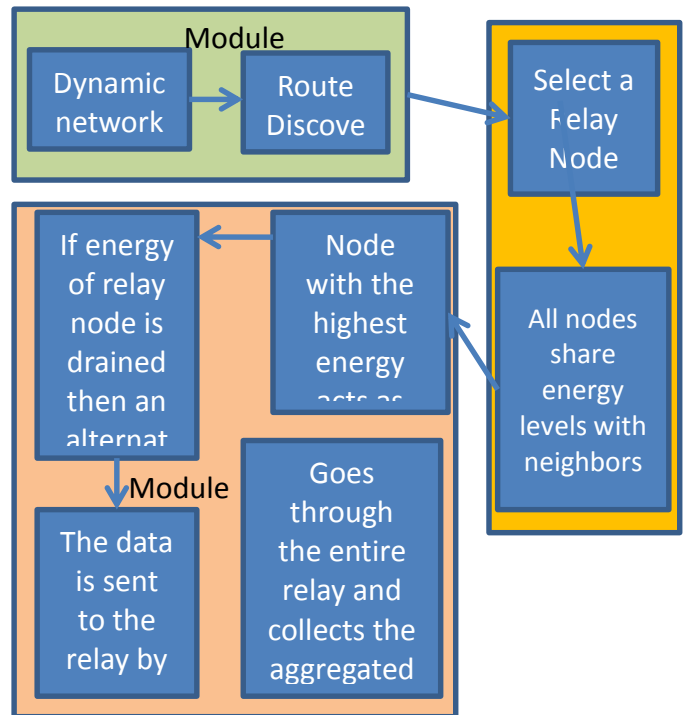

Fig.1: System Architecture Design

During, Detailed Design, the internal logic of each of the modules specified in system design is decided. During this phase, the details of the data of a module are usually specified

in a high-level design description language, which is independent of the target language in which the software will eventually be implemented. In system design the focus is on identifying the modules, whereas during detailed design the focus is on designing the logic for each of the modules. In other works, in system design the attention is on what components are needed, while in detailed design how the components can be implemented in software is the issue. Design is concerned with identifying software components specifying relationships among components. Specifying software structure and providing blue print for the document phase. Modularity is one of the desirable properties of large systems. It implies that the system is divided into several parts. In such a manner, the interaction between parts is minimal clearly specified. During the system design activities, Developers bridge the gap between the requirements specification, produced during requirements elicitation and analysis, and the system that is delivered to the user. Design is the place where the quality is fostered in development. Software design is a process through which requirements are translated into a representation of software.

A. UML Diagrams

1) Use case diagram-

This diagram shows the relation between the various nodes in the network with various other nodes, and how they react to each other.

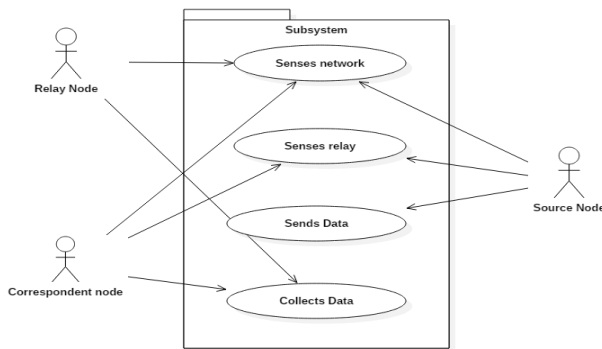

Fig.2: Use case diagram showing the node relations

2) Class Diagram-

This diagram shows how various classes interact with each other; the sendData class has 2 attributes names Energy level and Node ID to identify each node uniquely. Similarly the Generate nodes class is used to generate nodes, Node class contains the information regarding the nodes.

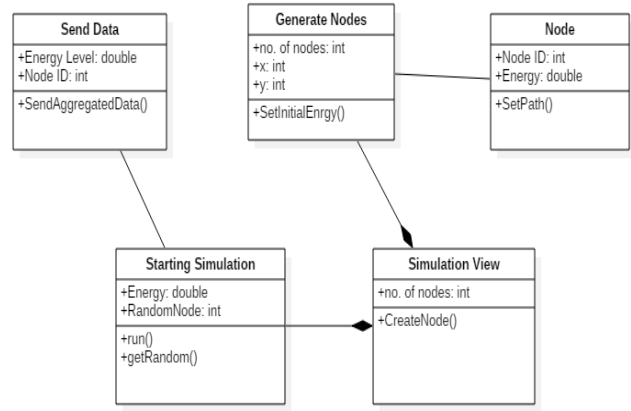

Fig.3: Class Diagram

3) Sequence Diagram-

The Source node and the Relay node sense the channel, if it is free then the source selects a relay with maximum energy, then the request message is sent and the source waits to receive a response message, then the RTS/CTS are exchanged. Later the data is sent to the destination and the ACK is received. This process is repeated till the node is exhausted out of energy.

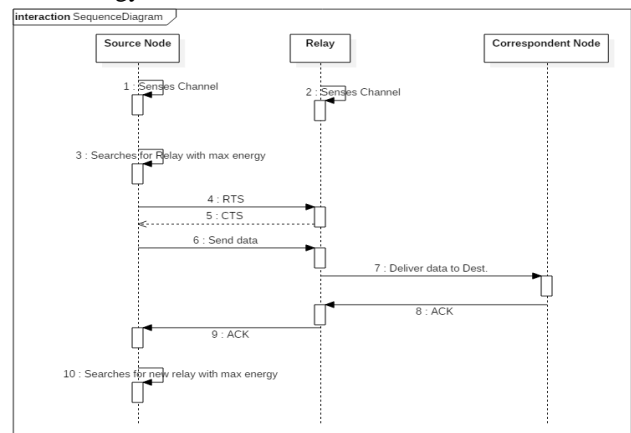

Fig.4: Sequence Diagram

4) Communication Diagram-

The Source node and the Relay node sense the channel, if it is free then the source selects a relay with maximum energy, then the request message is sent and the source waits to receive a response message, then the RTS/CTS are exchanged. Later the data is sent to the destination and the ACK is received. This process is repeated till the node is exhausted out of energy.

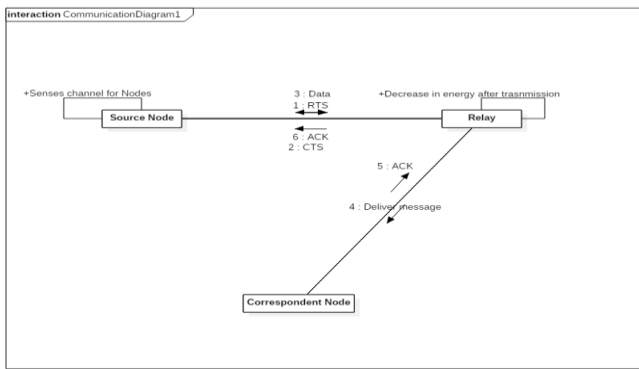

Fig.5: Communication Diagram

5) Activity Diagram-

The Source node and the Relay node sense the channel, if it is free then the source selects a relay with maximum energy, then the request message is sent and the source waits to receive a response message, then the RTS/CTS are exchanged. Later the data is sent to the destination and the ACK is received. This process is repeated till the node is exhausted out of energy.

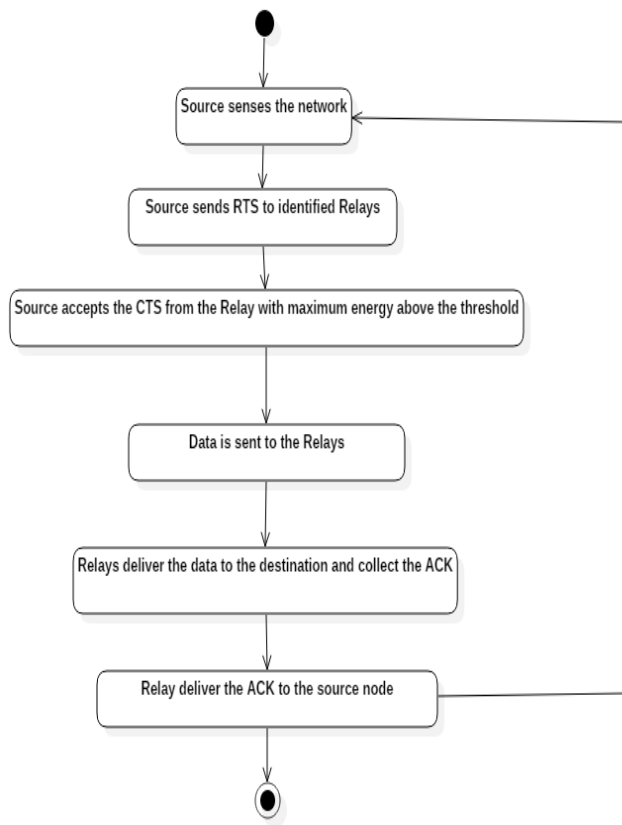

Fig.6: Activity Diagram

6) State Chart Diagram-

The Source node and the Relay node sense the channel, if it is free then the source selects a relay with maximum energy, then the request message is sent and the source waits to receive a response message, then the RTS/CTS are exchanged. Later the data is sent to the destination and the ACK is received. This process is repeated till the node is exhausted out of energy.

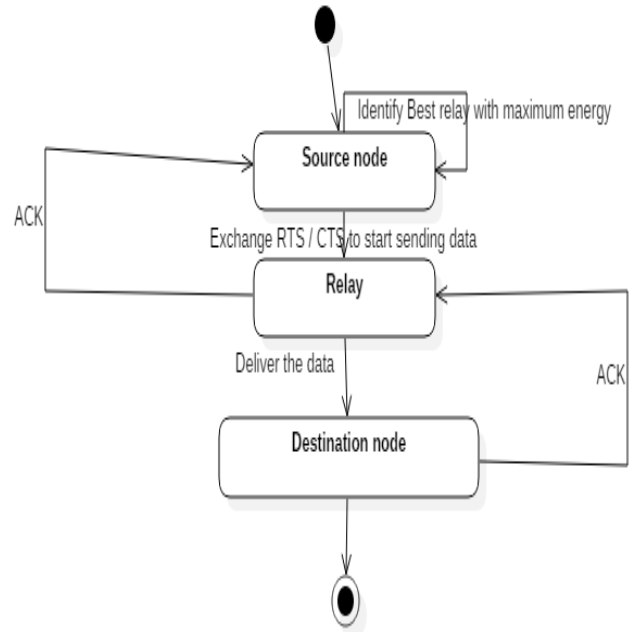

Fig.7: State Chart Diagram

7) Component Diagram-

Basically there are 3 different components in our system; they are Source, Relay and Destination. They are all associated with each other.

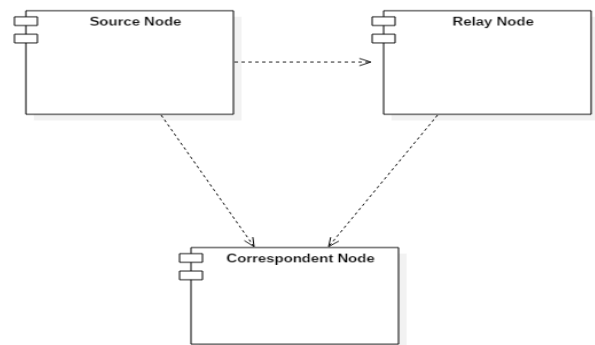

Fig.8: Component Diagram

8) Deployment Diagram-

The deployment diagram consists of Nodes namely the Source, Relay and Destination and they each handle a different part in the system.

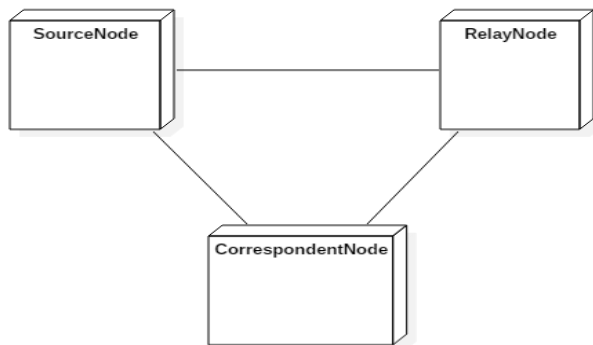

Fig.9:Deployment Diagram

V. SYSTEM IMPLEMENTATIONS

Implementation is the stage where the theoretical design is turned in to working system. The most crucial stage is achieving a new successful system and in giving confidence on the new system for the users that it will work efficiently and effectively. The system can be implemented only after through testing is done and if it found to work according to the specification. It involves careful planning, investigation of the current system and its constraints on implementation, design of methods to achieve the changeover and an evaluation of change over methods a part from planning. Two major tasks of preparing the implementation are education and training of the users and testing of the system.

The more complex the system being implemented, the more involved will be the systems analysis and design effort required just for implementation. The implementation phase comprises of several activities. The required hardware and software acquisition is carried out. The System may require some hardware and software acquisition is carried out. The system may require some software to be developed. For this, programs are written and tested. The user then changes over to his new fully tested system and the old system is discontinued. Implementation is the process of having systems personnel check out and put new equipment in to use, train users, install the new application, and construct any files of data needed to it.

Depending on the size of the organization that will be involved in using the application and the risk associated with its use, system developers may choose to test the operation in only one area of the firm, say in one department or with only one or two persons. Sometimes they will run the old and new systems together to compare the results. In still other

situations, developers will stop using the old system one-day and begin using the new one the next. As we will see, each implementation strategy has its merits, depending on the business situation in which it is considered. Regardless of the implementation strategy used, developers strive to ensure that the system's initial use in trouble-free.

VI. TESTING

A. Testing Methodologies-

Testing is the process of finding differences between the expected behavior specified by system models and the observed behavior implemented system. From modeling point of view, testing is the attempt of falsification of the system with respect to the system models. The goal of testing is to design tests that exercise defects in the system and to reveal problems. The process of executing a program with intent of finding errors is called testing. During testing, the program to be tested is executed with a set of test cases, and the output of the program for the test cases is evaluated to determine if the program is performing as expected. Testing forms the first step in determining the errors in the program. The success of testing in revealing errors in program depends critically on test cases.

B. Strategic Approach to Software Testing-

The software engineering process can be viewed as a spiral. Initially system engineering defines the role of software and leads to software requirements analysis where the information domain, functions, behaviour, performance, constraints and validation criteria for software are established. Moving inward along the spiral, we come to design and finally to coding. To develop computer software we spiral in along streamlines that decreases the level of abstraction on each item.

C. Different Levels of Testing

- 1) Client Needs
- 2) Acceptance Testing
- 3) Requirements System Testing
- 4) Design Integration Testing
- 5) Code Unit Testing

Testing is the process of finding difference between the expected behaviour specified by system models and the observed behaviour of the implemented system.

VII. RESULTS



Fig.11: Output for first sequence of nodes

```

19 }
20 System.out.println("Enter threshold energy");
21 tenergy = STDIN_SCANNER.nextInt();
22 System.out.println("Enter source node");
23 src = STDIN_SCANNER.nextInt();
24 System.out.println("Enter dest node");
25 dest = STDIN_SCANNER.nextInt();
26 largest = energy[0];
27 for(int i = 1; i < tnode; i++) {
28     if(largest < energy[i]) {
29         largest = energy[i];
30     }
31     relay = nodes[i];
32 }
33 if(largest > tenergy) {
34     System.out.println("In " + relay + " is node with largest energy in the network that is : " + largest);
35     System.out.println("In The optimal path from src " + src + " to dest " + dest + " is through the node " + relay);
36     largest = largest - 13;
37     System.out.println("In Energy of relay node after message transmission is " + largest);
38 }
39 }
40
41 public final static Scanner STDIN_SCANNER = new Scanner(System.in);
42 }

```

Fig.10:Standard Input to run the program

```
$javac demo/DemoTranslation.java
```

```
$java -Xmx128M -Xms16M demo/DemoTranslation
```

```

Enter total no. of nodes
Enter the sequence of nodes
Enter energies of all nodes
Enter threshold energy
Enter source node
Enter dest node

```

```

3 is node with largest energy in the network that is : 60
The optimal path from src 1 to dest 4 is through the node 3
Energy of relay node after message transmission is 47

```

VIII. CONCLUSION

We check the energy of the relay node; if it is below some threshold then new relay will be assigned to the correspondent node. Our algorithm tries to change the relay of the nodes if a node is running out of the energy; it helps to minimize the dropped packets. Also the proposed scheme gives the better performance in terms of throughput. Our scheme basically considers the energy of the node as well as the position of the node; it helps to produce best result.

A. *Scope for future Enhancements*-By changing the algorithm with more efficient one the message delay can be reduced. We would like to apply the algorithm to application layer or transport layer to enhance the security.

REFERENCES

- [1] C. Lu et al., "RAP: A Real-Time Communication Architecture for Large-Scale Wireless Sensor Networks," to appear in Proc. 8th Real-Time and Embedded Technology and Applications Symp. (RTAS 2002), IEEE CS Press, Los Alamitos, Calif., 2002.
- [2] G. Anastasi, M. Conti, and M. Di Francesco, "Extending the lifetime of wireless sensor networks through adaptive sleep," IEEE Trans. Ind. Informat., vol. 5, no. 3, pp. 351–365, Aug. 2009.
- [3] Tian, H., Shen, H., & Sang, Y. P. (2013). Maximizing network lifetime in wireless sensor networks with regular topologies. *The Journal of Supercomputing*, 69(2), 512–527.
- [4] Ms.Namrata S. Baghele, "An Adaptive Energy Aware Node Scheduling Scheme In Clustering for Wireless Sensor Networks", 2012
- [5] H. Kaur and J. Baek, "A strategic deployment and cluster-header selection for wireless sensor networks," IEEE Transactions on Consumer Electronics, vol. 55, no. 4, November 2009.
- [6] Ghosh, Ashim Kumar, Anupam Kumar Bairagi, M. Abul Kashem, D. M. A. Kashem, M. Rezwani-ul-Islam, and AJM Asraf Uddin, "Energy efficient zone division multihop hierarchical clustering algorithm for load balancing in wireless sensor network," International Journal of Advanced Computer Science and Applications 2, no. 12 (2011): 92-97.
- [7] E. Hansen, J. Neander, M. Nolin, and M. Björkman, "Energy-efficient cluster formation for large sensor networks using a minimum separation distance," in In The Fifth Annual Mediterranean Ad Hoc Networking Workshop, Lipari, Italy, June 2006.
- [8] S.C. Ergen and P. Varaiya, "TDMA Scheduling Algorithms for Sensor Networks," technical report, UC Berkeley, July 2005.